



APPROVAL SHEET

Approval Specification	Customer's Approval Certificate
TO:	Please return this copy as a certification of your approval
Part No.:	Checked & Approved by:
Customer's Part No.:	Date:

BEIJING ZHONGXUN SIFANG SCIENCE & TECHNOLOGY CO.,LTD.

Tel: +86-010-58937383
Fax: +86-010-58937263
E-mail: zxsf_sales@163.com
QQ: 2109300457
Website: <http://www.bjzxsf.net>
Add: No 201, Block A. Building 3. Yongjie Beilu
Yongfeng high-tech industrial base
Haidian District Beijing city



Part No.	:	SF9613
Pages	:	7
Date	:	2013/11/12
Revision	:	1.0

Prepared by:	王招林
Checked by:	杨宗伟
Approved by:	刘纪军

Application

- Low-loss SAW component for mobile systems
- Low amplitude ripple
- Sharp rejections at both out-bands
- Usable passband 25.0 MHz

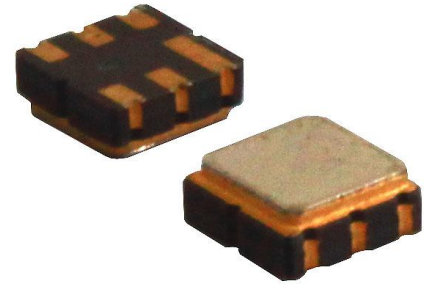

Features

- Ceramic Package for **Surface Mounted Technology (SMT)**
- **RoHS** compatible
- Package size 3.00x3.00x1.25mm³
- Package Code DCC6C
- **Electrostatic Sensitive Device(ESD)**

Package Dimensions (DCC6C)

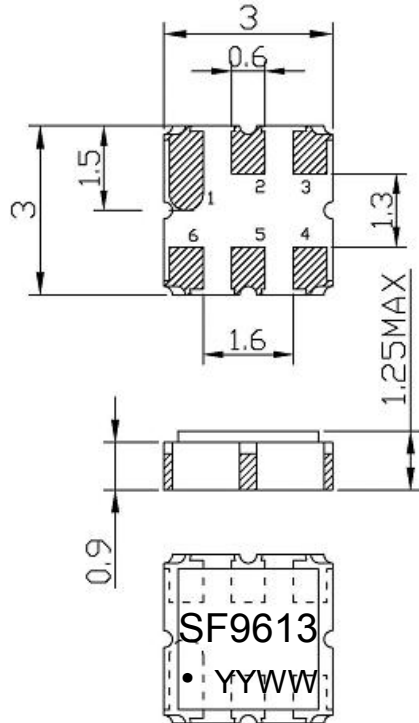

Pin Configuration

Pin No.	Description
2	Input
5	Output
1,3,4,6	Case Ground

Marking Description

SF	SF	Trademark
	F	SAW Filter
9613	Part Number	
●	Pin 1	
YYWW	Year Code & Week Code	

*Fig: If the products produced in 06th week of 2015, The year code & week code is 1506.

Test Circuit (Bottom View)

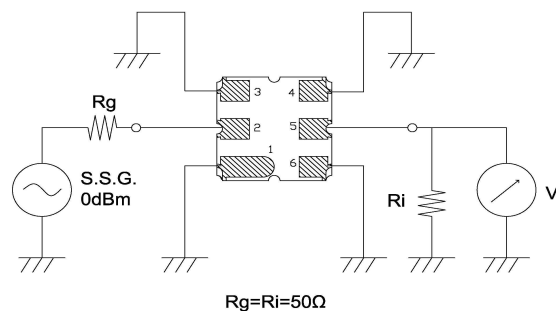

Performance

Maximum Rating

Item		Value	Unit
DC Voltage	V_{DC}	3	V
Operation Temperature	T	-40 ~ +85	°C
Storage Temperature	T_{stg}	-55 ~ +125	°C
RF Power Dissipation	P	10	dBm

Electronic Characteristics

Test Temperature: $25^{\circ}\text{C} \pm 2^{\circ}\text{C}$

Terminating source impedance: 50Ω

Terminating load impedance: 50Ω

Item		Minimum	Typical	Maximum	Unit
Center Frequency	f_c		947.5		MHz
Insertion Loss(min)	IL		1.4	2.0	dB
Insertion Loss	935.00 - 960.00MHz	IL	2.1	3.2	dB
Amplitude Ripple (p-p)	935.00 - 960.00MHz	$\Delta\alpha$	0.9	2.0	dB
Group Delay Ripple	935.00 - 960.00MHz	GDR	40.0	100.0	ns
Absolute Attenuation		α			
	DC- 700.00 MHz		45.0	52.0	dB
	700.00 - 910.00 MHz		45.0	52.0	dB
	910.00 - 925.00 MHz		25.0	40.0	dB
	975.00 -1000.00 MHz		20.0	25.0	dB
	1000.00 - 2000.00 MHz		45.0	50.0	dB
	2000.00 - 3000.00 MHz		30.0	35.0	dB
Input VSWR	935.00 - 960.00MHz		1.8:1	2.0:1	/
Output VSWR	935.00 - 960.00MHz		1.8:1	2.0:1	/

Frequency Characteristics

Frequency Response

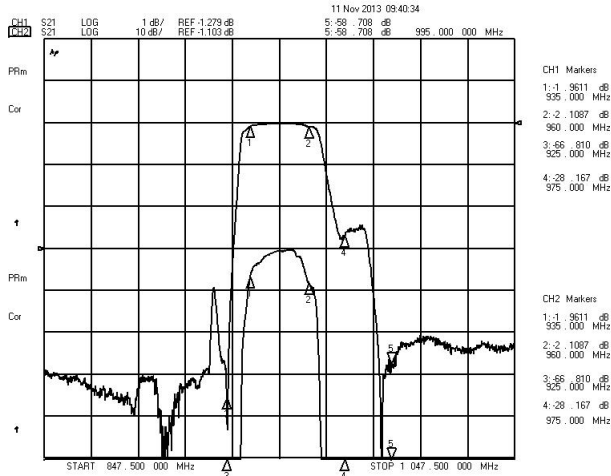

Frequency Response (wideband)

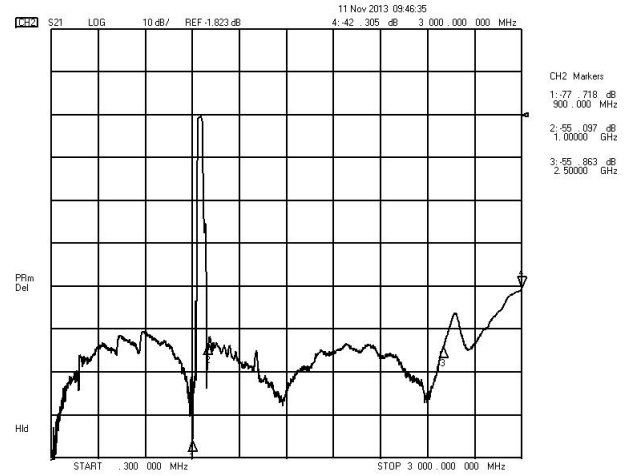

Delay Ripple & S11 VSWR

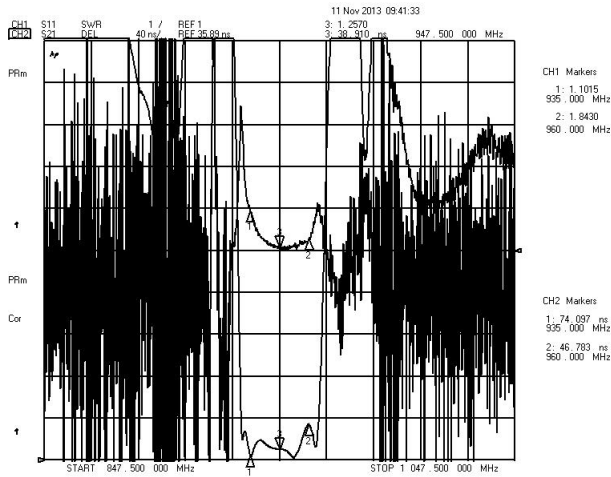

Phase Linearity & S22 VSWR

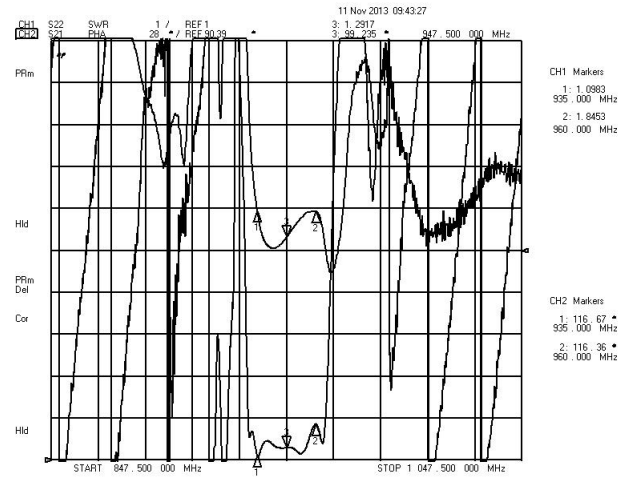

S11 Smith Chart

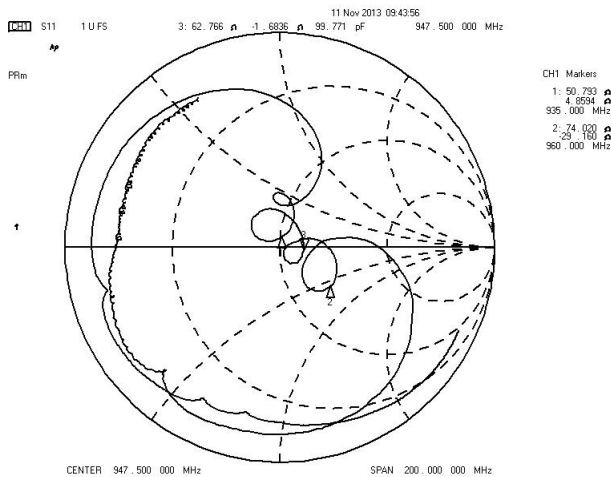

S22 Smith Chart

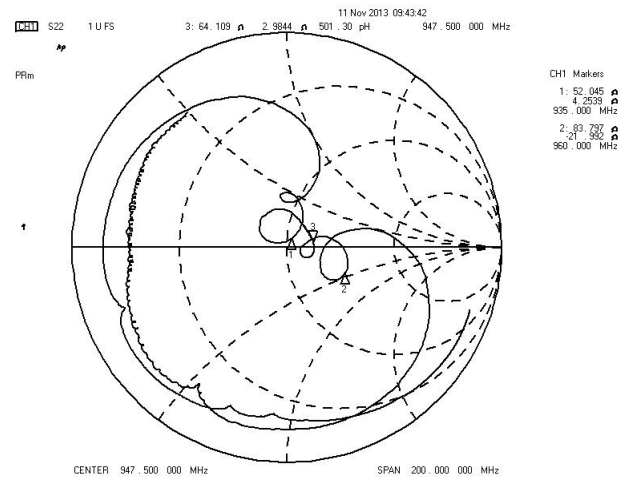

Reliability (The SAW components shall remain electrical performance after tests)

No.	Test item	Test condition
1	Temperature Storage	(1) Temperature: 85℃±2℃ , Duration: 250h , Recovery time: 2h±0.5h (2) Temperature: -55℃±3℃ , Duration: 250h ,Recovery time: 2h±0.5h
2	Humidity Test	Conditions: 60℃±2℃ , 90~95% RH Duration: 250h
3	Thermal Shock	Heat cycle conditions: TA=-55℃±3℃, TB=85℃±2℃, t1=t2=30min, Switch time: ≤3min, Cycle time: 100 times, Recovery time: 2h±0.5h.
4	Vibration Fatigue	Frequency of vibration: 10~55Hz Amplitude:1.5mm Directions: X,Y and Z Duration: 2h
5	Drop Test	Cycle time: 10 times Height: 1.0m
6	Solder Ability Test	Temperature: 245℃±5℃ Duration: 3.0s--5.0s Depth: DIP--2/3 , SMD--1/5
7	Resistance to Soldering Heat	(1)Thickness of PCB:1mm , Solder condition: 260℃±5℃ , Duration: 10±1s (2)Temperature of Soldering Iron: 350℃±10℃, Duration: 3~4s, Recovery time : 2 ± 0.5h

Recommended Reflow Soldering Diagram

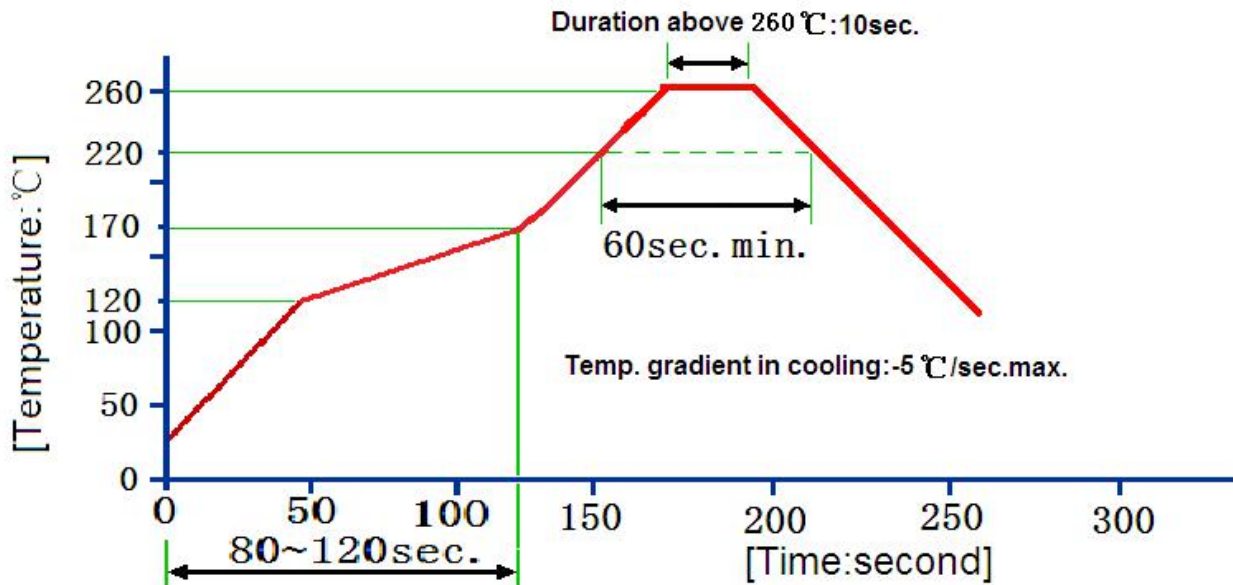

Reflow cycles:3 cycles max.

Packing Information

Carrier Tape

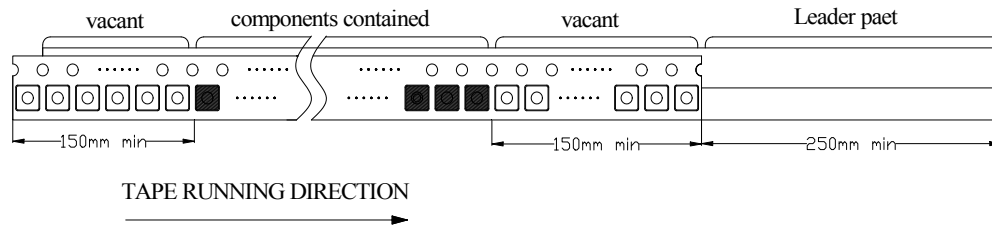

Reel Dimensions

Unit: mm

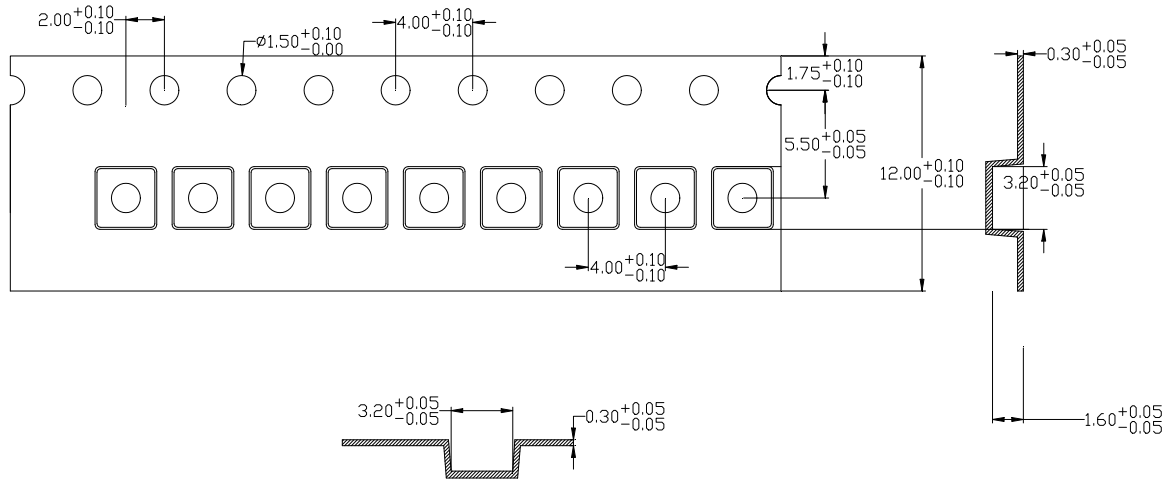

Outer Packing

Unit: mm

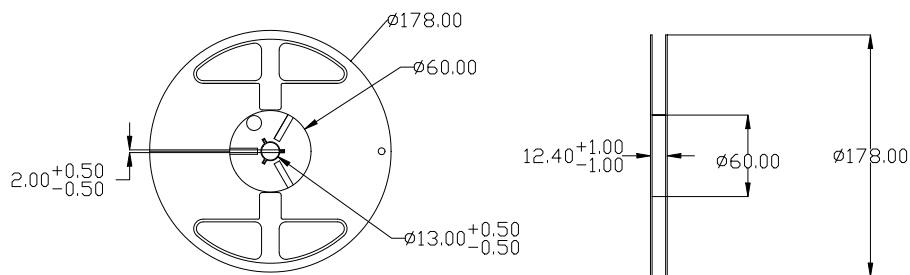

3000 pcs/reel

Type	Quantity	Dimension	Description	Weight
Internal box	6000	190×188×42	carton box 2 reel / internal box 5 boxes / external box	0.50
External box	30000	235×205×210		2.77

Unit: mm

Unit: kg

Notes

1. As a result of the particularity of inner structure of SAW products, it easy to be breakdown by electrostatic, so we should pay attention to **ESD protect** in the test.
2. **Static voltage** between signal load and ground may cause deterioration and destruction of the component. Please avoid static voltage.
3. **Ultrasonic cleaning** may cause deterioration and destruction of the component. Please avoid ultrasonic cleaning.
4. Only leads of component may **be soldered**. Please avoid soldering another part of component.
5. There is a close relationship between the device's performance and **matching network**. The specifications of this device are based on the test circuit shown above. L and C values may change depending on board layout. Values shown are intended as a guide only.