

**BIDIRECTIONAL INSTRUMENTATION
 BUS (GPIB) TRANSCEIVER**

This bidirectional bus transceiver is intended as the interface between TTL or MOS logic and the IEEE Standard Instrumentation Bus (488-1978, often referred to as GPIB). The required bus termination is internally provided.

Each driver/receiver pair forms the complete interface between the bus and an instrument. Either the driver or the receiver of each channel is enabled by its corresponding Send/Receive input with the disabled output of the pair forced to a high impedance state. An additional option allows the driver outputs to be operated in an open collector⁽¹⁾ or active pull-up configuration. The receivers have input hysteresis to improve noise margin, and their input loading follows the bus standard specifications.

- Four Independent Driver/Receiver Pairs
- Three-State Outputs
- High Impedance Inputs
- Receiver Hysteresis — 600 mV (Typ)
- Fast Propagation Times — 15–20 ns (Typ)
- TTL Compatible Receiver Outputs
- Single +5 Volt Supply
- Open Collector Driver Output Option⁽¹⁾
- Power Up/Power Down Protection
 (No Invalid Information Transmitted to Bus)
- No Bus Loading When Power Is Removed From Device
- Terminations Provided: Termination Removed When Device is Unpowered

⁽¹⁾ Selection of the "Open Collector" configuration, in fact, selects an open collector device with a passive pull-up load/termination which conforms to Figure 7, IEEE 488-1978 Bus Standard.

TRUTH TABLE

Send/Rec.	Enable	Info. Flow	Comments
0	X	Bus → Data	—
1	1	Data → Bus	Active Pull-Up
1	0	Data → Bus	Open Col.

X = Don't Care

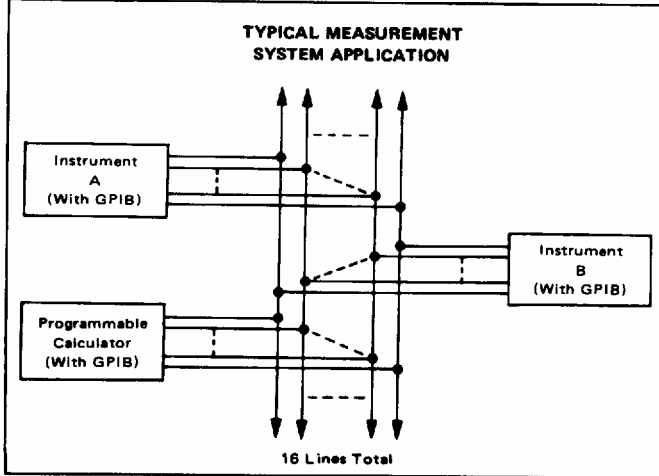

MC3448A

**QUAD THREE-STATE
 BUS TRANSCEIVER WITH
 TERMINATION NETWORKS**

**SILICON MONOLITHIC
 INTEGRATED CIRCUIT**

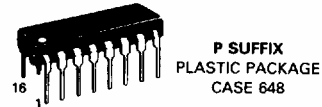
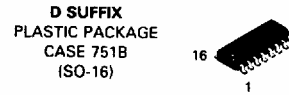
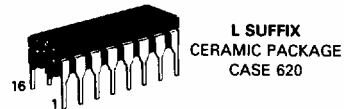

PIN CONNECTIONS

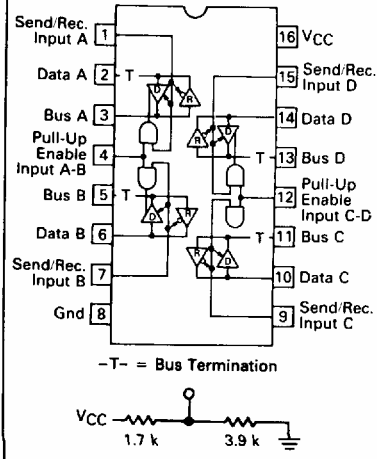

MC3448A

MAXIMUM RATINGS (T_A = 25°C unless otherwise noted)

Rating	Symbol	Value	Unit
Power Supply Voltage	V _{CC}	7.0	Vdc
Input Voltage	V _I	5.5	Vdc
Driver Output Current	I _{O(D)}	150	mA
Junction Temperature	T _J	150	°C
Operating Ambient Temperature Range	T _A	0 to +70	°C
Storage Temperature Range	T _{stg}	-65 to +150	°C

ELECTRICAL CHARACTERISTICS

(Unless otherwise noted 4.75 V ≤ V_{CC} ≤ 5.25 V and 0 ≤ T_A ≤ 70°C; typical values are at T_A = 25°C, V_{CC} = 5.0 V)

Characteristic	Symbol	Min	Typ	Max	Unit
Bus Voltage (Bus Pin Open) (V _{I(S/R)} = 0.8 V) (I _{I(BUS)} = -12 mA)	V _(BUS) V _{I(C)(BUS)}	2.75 -	- -	3.7 -1.5	V
Bus Current (5.0 V ≤ V _(BUS) ≤ 5.5 V) (V _{I(BUS)} = 0.5 V) (V _{CC} = 0 V, 0 V ≤ V _(BUS) ≤ 2.75 V)	I _(BUS)	0.7 -1.3 -	- - -	2.5 -3.2 +0.04	mA
Receiver Input Hysteresis (V _{I(S/R)} = 0.8 V)	-	400	600	-	mV
Receiver Input Threshold (V _{I(S/R)} = 0.8 V, Low to High) (V _{I(S/R)} = 0.8 V, High to Low)	V _{ILH(R)} V _{IHL(R)}	- 0.8	1.6 1.0	1.8 -	V
Receiver Output Voltage – High Logic State (V _{I(S/R)} = 0.8 V, I _{OH(R)} = -800 μA, V _(BUS) = 2.0 V)	V _{OH(R)}	2.7	-	-	V
Receiver Output Voltage – Low Logic State (V _{I(S/R)} = 0.8 V, I _{OL(R)} = 16 mA, V _(BUS) = 0.8 V)	V _{OL(R)}	-	-	0.5	V
Receiver Output Short Circuit Current (V _{I(S/R)} = 0.8 V, V _(BUS) = 2.0 V)	I _{OS(R)}	-15	-	-75	mA
Driver Input Voltage – High Logic State (V _{I(S/R)} = 2.0 V)	V _{IH(D)}	2.0	-	-	V
Driver Input Voltage – Low Logic State (V _{I(S/R)} = 2.0 V)	V _{IL(D)}	-	-	0.8	V
Driver Input Current – Data Pins (V _{I(S/R)} = V _{I(E)} = 2.0 V) (0.5 ≤ V _{I(D)} ≤ 2.7 V) (V _{I(D)} = 5.5 V)	I _{I(D)} I _{IB(D)}	-200 -	- -	40 200	μA
Input Current – Send/Receive (0.5 ≤ V _{I(S/R)} ≤ 2.7 V) (V _{I(S/R)} = 5.5 V)	I _{I(S/R)} I _{IB(S/R)}	-100 -	- -	20 100	μA
Input Current – Enable (0.5 ≤ V _{I(E)} ≤ 2.7 V) (V _{I(E)} = 5.5 V)	I _{I(E)} I _{IB(E)}	-200 -	- -	20 100	μA
Driver Input Clamp Voltage (V _{I(S/R)} = 2.0 V, I _{I(C)(D)} = -18 mA)	V _{I(C)(D)}	-	-	-1.5	V
Driver Output Voltage – High Logic State (V _{I(S/R)} = 2.0 V, V _{IH(D)} = 2.0 V, V _{IH(E)} = 2.0 V, I _{OH} = -5.2 mA)	V _{OH(D)}	2.5	-	-	V
Driver Output Voltage – Low Logic State (Note 1) (V _{I(S/R)} = 2.0 V, I _{OL(D)} = 48 mA)	V _{OL(D)}	-	-	0.5	V
Output Short Circuit Current (V _{I(S/R)} = 2.0 V, V _{IH(D)} = 2.0 V, V _{IH(E)} = 2.0 V)	I _{OS(D)}	-30	-	-120	mA
Power Supply Current (Listening Mode – All Receivers On) (Talking Mode – All Drivers On)	I _{CCL} I _{CCH}	- -	63 106	85 125	mA

SWITCHING CHARACTERISTICS (V_{CC} = 5.0 V, T_A = 25°C unless otherwise noted)

Propagation Delay of Driver (Output Low to High) (Output High to Low)	t _{PLH(D)} t _{PHL(D)}	- -	- -	15 17	ns
Propagation Delay of Receiver (Output Low to High) (Output High to Low)	t _{PLH(R)} t _{PHL(R)}	- -	- -	25 23	ns

NOTE 1. A modification of the IEEE 488-1978 Bus Standard changes V_{OL(D)} from 0.4 to 0.5 V maximum to permit the use of Schottky technology.

MC3448A

SWITCHING CHARACTERISTICS (continued) ($V_{CC} = 5.0 \text{ V}$, $T_A = 25^\circ\text{C}$ unless otherwise noted)

Characteristic	Symbol	Min	Typ	Max	Unit
Propagation Delay Time – Send/Receive to Data					ns
Logic High to Third State	$t_{PHZ(R)}$	–	–	30	
Third State to Logic High	$t_{PZH(R)}$	–	–	30	
Logic Low to Third State	$t_{PLZ(R)}$	–	–	30	
Third State to Logic Low	$t_{PZL(R)}$	–	–	30	
Propagation Delay Time – Send/Receive to Bus					ns
Logic High to Third State	$t_{PHZ(D)}$	–	–	30	
Third State to Logic High	$t_{PZH(D)}$	–	–	30	
Logic Low to Third State	$t_{PLZ(D)}$	–	–	30	
Third State to Logic Low	$t_{PZL(D)}$	–	–	30	
Turn-On Time – Enable to Bus					ns
Pull-Up Enable to Open Collector	$t_{POFF(E)}$	–	–	30	
Open Collector to Pull-Up Enable	$t_{PON(E)}$	–	–	20	

PROPAGATION DELAY TEST CIRCUITS AND WAVEFORMS

FIGURE 1 – BUS INPUT TO DATA OUTPUT (RECEIVER)

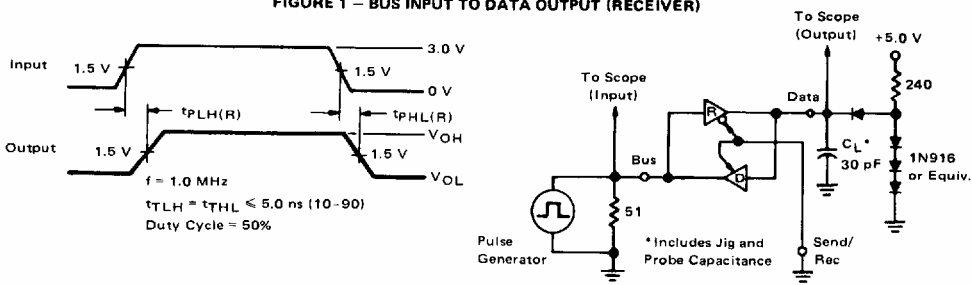

FIGURE 2 – DATA INPUT TO BUS OUTPUT (DRIVER)

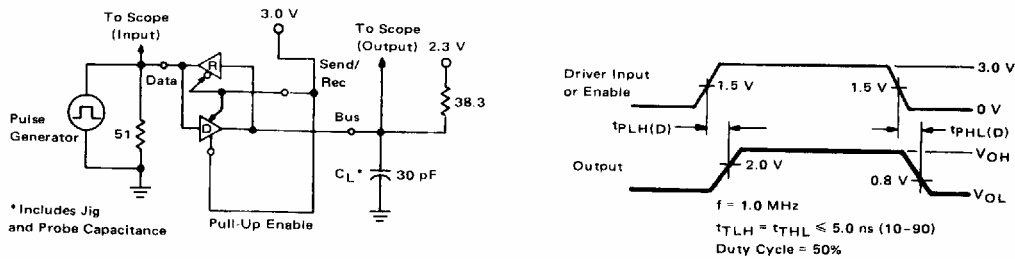

FIGURE 3 – SEND/RECEIVE INPUT TO BUS OUTPUT (DRIVER)

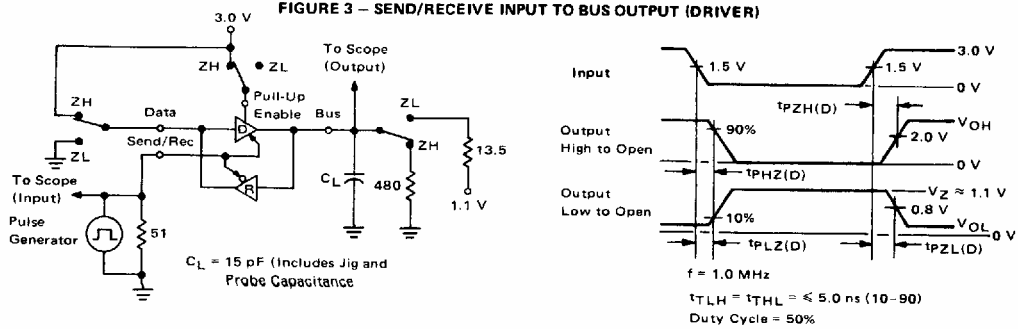

FIGURE 4 – SEND/RECEIVE INPUT TO DATA OUTPUT (RECEIVER)

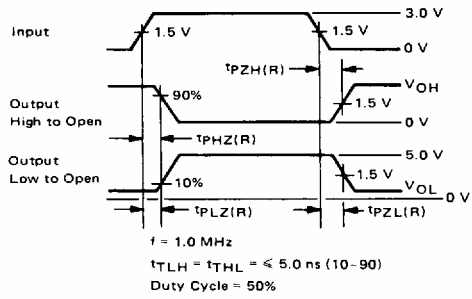
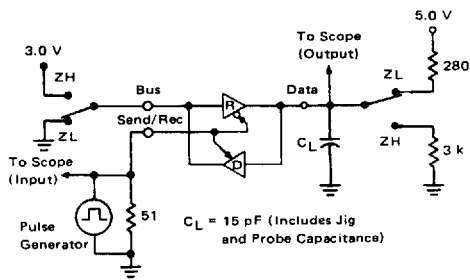

FIGURE 5 – ENABLE INPUT TO BUS OUTPUT (DRIVER)

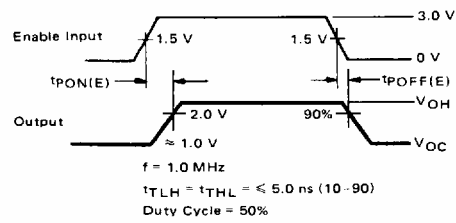
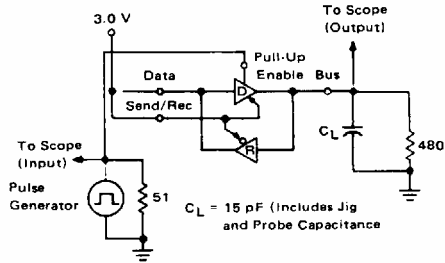

FIGURE 6 – TYPICAL RECEIVER HYSTERESIS CHARACTERISTICS

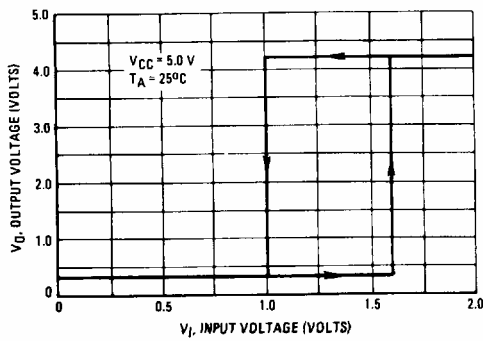
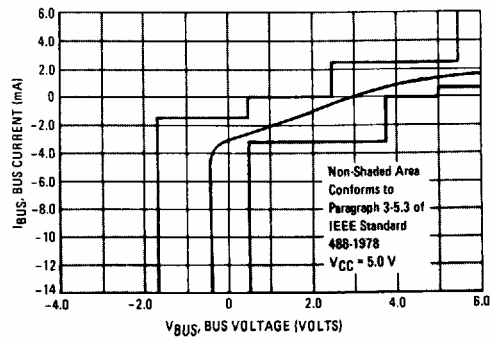
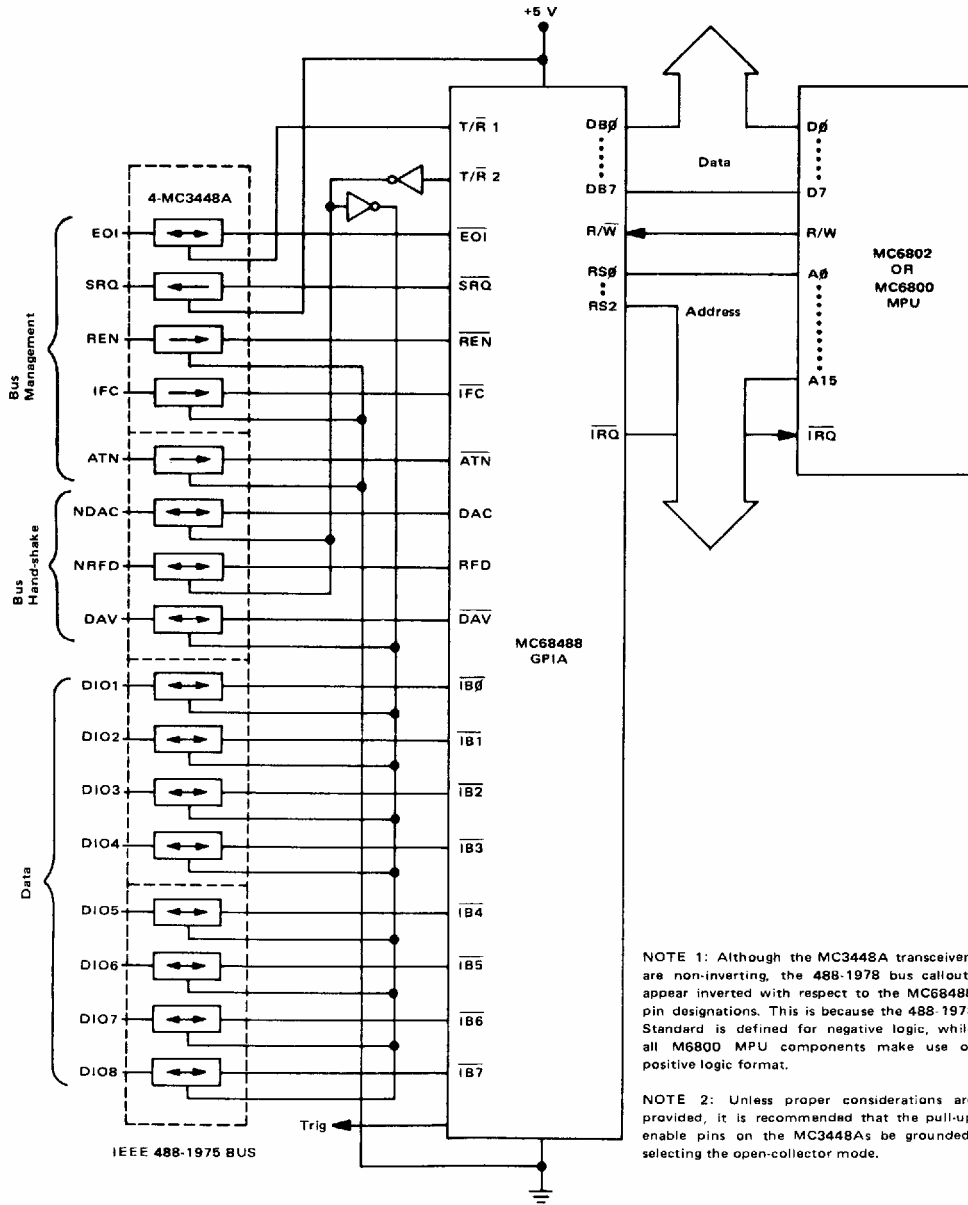

FIGURE 7 – TYPICAL BUS LOAD LINE



MC3448A

FIGURE 8 - SIMPLE SYSTEM CONFIGURATION



7