



# SAM-M10Q

**u-blox M10 standard precision GNSS antenna module**

Data sheet



## **Abstract**

This data sheet describes the SAM-M10Q antenna module with concurrent reception of four GNSS (GPS, Galileo, GLONASS, and BeiDou) and a simple design-in requiring no RF expertise.

[www.u-blox.com](http://www.u-blox.com)

UBX-22013293 - R05  
C1-Public



# Document information

<b>Title</b>	<b>SAM-M10Q</b>	
<b>Subtitle</b>	u-blox M10 standard precision GNSS antenna module	
<b>Document type</b>	Data sheet	
<b>Document number</b>	UBX-22013293	
<b>Revision and date</b>	R05	08-Apr-2024
<b>Disclosure restriction</b>	C1-Public	

<b>Product status</b>	<b>Corresponding content status</b>	
<b>Functional sample</b>	Draft	For functional testing. Revised and supplementary data will be published later.
<b>In development / prototype</b>	Objective specification	Target values. Revised and supplementary data will be published later.
<b>Engineering sample</b>	Advance information	Data based on early testing. Revised and supplementary data will be published later.
<b>Initial production</b>	Early production information	Data from product verification. Revised and supplementary data may be published later.
<b>Mass production / End of life</b>	Production information	Document contains the final product specification.

This document applies to the following products:

<b>Product name</b>	<b>Type number</b>	<b>FW version</b>	<b>IN/PCN reference</b>	<b>Product status</b>
SAM-M10Q	SAM-M10Q-00B-01	ROM SPG 5.10	UBXDOC-963802114-12186	Mass production

u-blox or third parties may hold intellectual property rights in the products, names, logos and designs included in this document. Copying, reproduction, or modification of this document or any part thereof is only permitted with the express written permission of u-blox. Disclosure to third parties is permitted for clearly public documents only.

The information contained herein is provided "as is" and u-blox assumes no liability for its use. No warranty, either express or implied, is given, including but not limited to, with respect to the accuracy, correctness, reliability and fitness for a particular purpose of the information. This document may be revised by u-blox at any time without notice. For the most recent documents, visit [www.u-blox.com](http://www.u-blox.com).

Copyright © 2024, u-blox AG.

# Contents

<b>1 Functional description.....</b>	<b>4</b>
1.1 Overview.....	4
1.2 Performance.....	4
1.3 Supported GNSS constellations.....	5
1.4 Supported protocols.....	6
1.5 Firmware features.....	6
1.6 Integrated antenna.....	7
<b>2 System description.....</b>	<b>8</b>
2.1 Block diagram.....	8
<b>3 Pin definition.....</b>	<b>9</b>
3.1 Pin assignment.....	9
3.2 Pin state.....	10
<b>4 Electrical specifications.....</b>	<b>11</b>
4.1 Absolute maximum ratings.....	11
4.2 Operating conditions.....	11
4.3 Indicative power requirements.....	12
<b>5 Communication interfaces.....</b>	<b>14</b>
5.1 UART.....	14
5.2 I2C.....	14
5.3 Default interface settings.....	15
<b>6 Mechanical specifications.....</b>	<b>16</b>
<b>7 Qualifications and approvals.....</b>	<b>17</b>
<b>8 Product handling.....</b>	<b>18</b>
8.1 Soldering.....	18
<b>9 Labeling and ordering information.....</b>	<b>19</b>
9.1 Product labeling.....	19
9.2 Explanation of product codes.....	19
9.3 Ordering codes.....	19
<b>Related documents.....</b>	<b>21</b>
<b>Revision history.....</b>	<b>22</b>

# 1 Functional description

## 1.1 Overview

SAM-M10Q patch-antenna module features the u-blox M10 standard precision GNSS platform and provides exceptional sensitivity and acquisition time for all L1 GNSS signals.

The M10 platform supports concurrent reception of four GNSS (GPS, GLONASS, Galileo, and BeiDou). The high number of visible satellites enables the receiver to select the best signals. This maximizes the position availability, in particular under challenging conditions such as in deep urban canyons.

u-blox Super-S (Super-Signal) technology offers great RF sensitivity and can improve the dynamic position accuracy in non-line-of-sight scenarios.

The extremely low power consumption of 37 mW in continuous tracking mode with four concurrent GNSS allows great power autonomy for all battery-operated devices, such as asset trackers, without compromising on GNSS performance.

A front-end SAW filter and an LNA is integrated in the SAM-M10Q module. This setup ensures excellent out-band jamming immunity, for example when a cellular modem is nearby. SAM-M10Q also detects jamming and spoofing attempts and reports them to the host, so that the system can react to such events.

The high-gain 15 x 15 mm<sup>2</sup> patch antenna provides the best balance between performance and small size. The omnidirectional antenna radiation pattern increases flexibility for device installation.

Incorporating the SAM-M10Q module into customer designs is easy and straightforward, thanks to the integrated antenna, robust design, and simple interface. SAM-M10Q is a surface-mount device, enabling simple and automated manufacturing.

SAM-M10Q offers backwards pin-to-pin compatibility with products from the previous u-blox generations, which saves the designer's effort and reduces costs when upgrading designs to the advanced low-power u-blox M10 GNSS technology.

## 1.2 Performance

Parameter	Specification	Value
Receiver type		u-blox M10 receiver
Accuracy of time pulse signal	RMS	30 ns
	99%	60 ns
Frequency of time pulse signal		Default 1PPS (0.25 Hz to 10 MHz configurable)
Operational limits <sup>1</sup>	Dynamics	≤ 4 g
	Altitude	80,000 m
	Velocity	500 m/s
Velocity accuracy <sup>2</sup>		0.05 m/s
Dynamic heading accuracy <sup>2</sup>		0.3 deg

<sup>1</sup> Assuming Airborne 4 g platform

<sup>2</sup> 50% at 30 m/s for dynamic operation

Parameter		GPS+GAL +BDS B1C+GLO (default)	GPS+GAL+GLO	GPS+GAL +BDS B1C	GPS+GAL
Max navigation update rate <sup>3</sup>	Default	4 Hz	6 Hz	8 Hz	10 Hz
	High performance <sup>4</sup>	10 Hz	16 Hz	16 Hz	20 Hz
Position accuracy (CEP) <sup>5, 6</sup>		1.5 m	1.5 m	1.5 m	1.5 m
Time To First Fix (TTFF) <sup>5, 7, 8</sup>	Cold start	23 s	23 s	28 s	28 s
	Hot start	1 s	1 s	1 s	1 s
	AssistNow Online <sup>9</sup>	1 s	1 s	1 s	1 s
	AssistNow Offline <sup>10</sup>	2	2	2	2
	AssistNow Autonomous <sup>11</sup>	4	4	4	3
Sensitivity <sup>12</sup>	Tracking and navigation	-165 dBm	-165 dBm	-165 dBm	-165 dBm
	Reacquisition	-158 dBm	-158 dBm	-158 dBm	-158 dBm
	Cold Start	-146 dBm	-146 dBm	-146 dBm	-146 dBm
	Hot start <sup>7</sup>	-157 dBm	-157 dBm	-157 dBm	-157 dBm

**Table 1: SAM-M10Q typical performance in multi-constellation GNSS modes.**

Parameter		GPS	GLONASS	GALILEO	BDS B1C
Max navigation update rate <sup>3</sup>	Default	18 Hz	18 Hz	18 Hz	18 Hz
	High performance <sup>4</sup>	25 Hz	25 Hz	25 Hz	25 Hz
Position accuracy (CEP) <sup>5, 6</sup>		1.5 m	4 m	3 m	2 m
Time To First Fix (TTFF) <sup>5, 7, 8</sup>	Cold start	29 s	27 s	41 s	56 s
	Hot start	1 s	1 s	1 s	1 s
	AssistNow Online <sup>9</sup>	1 s	1 s	5 s	N/A
Sensitivity <sup>12</sup>	Tracking and navigation	-165 dBm	-164 dBm	-159 dBm	-161 dBm
	Reacquisition	-158 dBm	-156 dBm	-152 dBm	-154 dBm
	Cold Start	-146 dBm	-145 dBm	-139 dBm	-134 dBm
	Hot start <sup>7</sup>	-157 dBm	-157 dBm	-153 dBm	-155 dBm

**Table 2: SAM-M10Q typical performance in single-GNSS modes**

### 1.3 Supported GNSS constellations

SAM-M10Q is a concurrent GNSS receiver that can receive and track multiple GNSS systems. The single RF front-end architecture enables concurrent reception of multiple GNSS constellations. The receiver can be configured for a subset of GNSS constellations to achieve lower power consumption.

<sup>3</sup> Minimum 98% fix rate under typical conditions.

<sup>4</sup> Configuration required.

<sup>5</sup> GPS is always in combination with SBAS and QZSS.

<sup>6</sup> CEP, 50%, 24 hours static, -130 dBm, > 6 SVs for each GNSS system

<sup>7</sup> Commanded starts.

<sup>8</sup> All satellites at -130 dBm. Measured at room temperature.

<sup>9</sup> Dependent on the speed and latency of the aiding data connection, commanded starts.

<sup>10</sup> Using seven days old AssistNow Offline data. External memory may be required.

<sup>11</sup> Using two days old orbital predicted data. External memory may be required.

<sup>12</sup> On a 50 x 50 mm<sup>2</sup> ground plane. Measured at room temperature.

The default configuration on SAM-M10Q is concurrent reception of GPS, Galileo, GLONASS, and BeiDou B1C with QZSS and SBAS enabled.

The following GNSS and their signals are supported:

System	Signals
GPS / QZSS	L1C/A (1575.42 MHz)
Galileo	E1-B/C (1575.42 MHz)
GLONASS	L1OF (1602 MHz + k*562.5 kHz, k = -7,..., 5, 6)
BeiDou	B1C (1575.42 MHz)

**Table 3: Supported GNSS and signals on SAM-M10Q**

The following GNSS assistance services are supported:

Service	Support
AssistNow™ Online	GPS L1C/A, Galileo E1, QZSS L1C/A, GLONASS L1OF, BeiDou B1I
AssistNow™ Offline	GPS L1C/A, Galileo E1, GLONASS L1OF
AssistNow™ Autonomous	GPS L1C/A, Galileo E1, GLONASS L1OF, QZSS L1C/A, BeiDou B1I

**Table 4: Supported Assisted GNSS (A-GNSS) services**

The following augmentation systems are supported:

System	Support
SBAS	EGNOS, GAGAN, MSAS, WAAS and BDSBAS
QZSS	L1S (SLAS)

**Table 5: Supported augmentation systems**

The augmentation systems SBAS and QZSS can be enabled only if GPS operation is also enabled.

## 1.4 Supported protocols

SAM-M10Q supports the following interface protocols:

Protocol	Type
UBX	Input/output, binary, u-blox proprietary
NMEA versions 2.1, 2.3, 4.0, 4.10 and 4.11 (default)	Input/output, ASCII

**Table 6: Supported protocols**

## 1.5 Firmware features

Feature	Description
CloudLocate GNSS	Extends the life of energy-constrained IoT applications. Small payload messages supported.
Assisted GNSS	AssistNow Online, AssistNow Offline and AssistNow Autonomous
Backup modes	Hardware backup mode and software standby mode
Super-S	Improved dynamic position accuracy with small antennas
Protection level	Real-time position accuracy estimate with 95% confidence level <sup>13</sup>
Galileo return link messages	Galileo search and rescue (SAR) return link messages (RLM) via Galileo satellite signal

<sup>13</sup> Verified for automotive environment only.

Feature	Description
Data batching	Autonomous tracking up to 10 minutes at 1 Hz
Odometer	Measure traveled distance with support for different user profiles

**Table 7: Firmware features**

Feature	Description
Anti-jamming	RF interference and jamming detection and reporting
Anti-spoofing	Spoofing detection and reporting
Configuration lockdown	Receiver configuration can be locked by command
Message integrity	All messages can be cryptographically signed
Secure boot	Only signed firmware images are executed

**Table 8: Security features**

## 1.6 Integrated antenna

SAM-M10Q module includes an integrated GNSS patch antenna. The RF signal is further filtered and amplified by an internal SAW filter and a low-noise amplifier (LNA).



The application PCB is a part of the antenna solution and the PCB layout has an impact on the antenna performance.

The antenna is right-hand circular polarized (RHCP) and has a peak gain of 3 dBic. The antenna is insensitive to surroundings and has high tolerance against frequency detuning. However, the antenna gain and radiation efficiency may be reduced on a small ground plane. The optimal radiation pattern is achieved with a 50 x 50 mm<sup>2</sup> ground plane.

The operating frequency of the antenna has been tuned in the antenna production. The tuning involves removing small parts of the antenna metalization, and this may show as shallow scratches in the antenna element.

## 2 System description

### 2.1 Block diagram

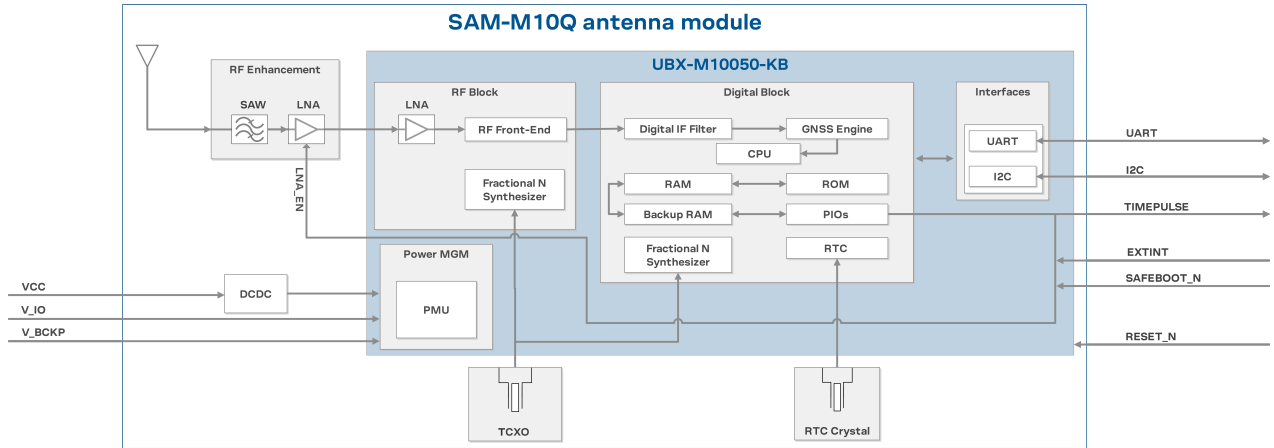

Figure 1: SAM-M10Q block diagram



## 3 Pin definition

### 3.1 Pin assignment

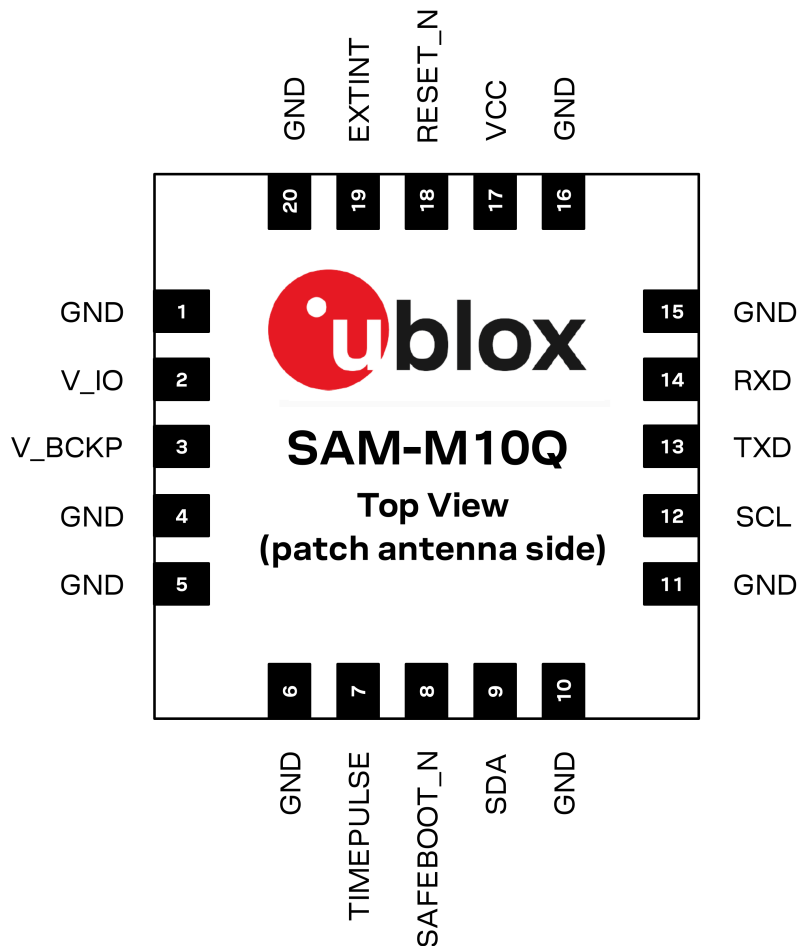

Figure 2: SAM-M10Q pin assignment

Pin no.	Name	PIO no.	I/O	Description
1	GND	-	-	Connect to GND
2	V_IO	-	I	IO voltage supply
3	V_BCKP	-	I	Backup voltage supply
4	GND	-	-	Connect to GND
5	GND	-	-	Connect to GND
6	GND	-	-	Connect to GND
7	TIMEPULSE	4	O	Time pulse signal (shared with SAFEBOOT_N pin) <sup>14</sup>
8	SAFEBOOT_N	-	I	Safeboot mode (active low). Leave open if not used. <sup>14</sup>

<sup>14</sup> The receiver enters safeboot mode if this pin is low at start up. The SAFEBOOT\_N pin is internally connected to TIMEPULSE pin through a 1 kΩ series resistor.

Pin no.	Name	PIO no.	I/O	Description
9	SDA	2	I/O	I2C data. Leave open if not used.
10	GND	-	-	Connect to GND
11	GND	-	-	Connect to GND
12	SCL	3	I	I2C clock. Leave open if not used.
13	TXD	1	O	UART TX. Leave open if not used.
14	RXD	0	I	UART RX. Leave open if not used.
15	GND	-	-	Connect to GND
16	GND	-	-	Connect to GND
17	VCC	-	I	Main voltage supply
18	RESET_N	-	I	System reset (active low). Has to be low for at least 1 ms to trigger a reset.
19	EXTINT	5	I	External interrupt. Leave open if not used.
20	GND	-	-	Connect to GND

**Table 9: SAM-M10Q pin assignment**

## 3.2 Pin state

Table 10 defines the state of the PIOs and RESET\_N pins in different modes. The functions of the PIOs are as defined in the default configuration.

PIO no.	Pin no.	Default function	Continuous mode	Software standby mode	Safe boot mode
0	14	RXD	Input pull-up	Input pull-up	Input pull-up
1	13	TXD	Output	Input pull-up	Output
2	9	SDA	Input pull-up	Input pull-up	Input pull-up
3	12	SCL	Input pull-up	Input pull-up	Input pull-up
4 <sup>14</sup>	8	SAFEBOOT_N	Output	Input pull-up	Output (low)
	7	TIMEPULSE	Output	Input pull-up	Output (low)
5	19	EXTINT	Input pull-up	Input pull-up	Input pull-up
-	18	RESET_N	Input pull-up	Input pull-up	Input pull-up

**Table 10: Pins state**

In reset mode (RESET\_N = low), all PIOs are configured as input pull-up.



In hardware backup mode (VCC = 0 V and V\_IO = 0 V), PIOs must not be driven.

## 4 Electrical specifications

### 4.1 Absolute maximum ratings

- ⚠ CAUTION. Risk of device damage. Exceeding the absolute maximum ratings may affect the lifetime and reliability of the device or permanently damage it. Do not exceed the absolute maximum ratings.
- ⚠ This product is not protected against overvoltage or reversed voltages. Use appropriate protection to avoid device damage from voltage spikes exceeding the specified boundaries.

Symbol	Parameter	Min	Max	Unit
VCC	Main supply voltage	-0.3	3.6	V
V <sub>IO</sub>	IO supply voltage	-0.3	VCC + 0.3 (max 3.6)	V
	Voltage ramp on V <sub>IO</sub> <sup>15</sup>	25	35000	μs/V
V <sub>BCKP</sub>	Backup supply voltage	-0.3	3.6	V
V <sub>PIO</sub>	Input voltage on RESET_N and digital pins	-0.3	V <sub>IO</sub> + 0.3 (max 3.6)	V
I <sub>PIO</sub>	Max source / sink current, digital pins <sup>16</sup>	-10	10	mA
P <sub>rfin</sub>	RF input power at RF_IN <sup>17</sup>		0	dBm
T <sub>amb</sub>	Ambient temperature	-40	+85	°C
T <sub>s</sub>	Storage temperature	-40	+85	°C

Table 11: Absolute maximum ratings

### 4.2 Operating conditions

Table 12 shows the general operating conditions. Table 13 shows the electrical parameters for digital I/O.

Symbol	Parameter	Min	Typical	Max	Unit
VCC	Main supply voltage	2.7	3.0	3.6	V
V <sub>IO</sub>	IO supply voltage	2.7	3.0	VCC (max 3.6)	V
V <sub>BCKP</sub>	Supply voltage, backup domain	1.65		3.6	V
V <sub>IOSWITCH</sub>	V <sub>IO</sub> voltage threshold to switch an internal supply for the backup domain from V <sub>IO</sub> to V <sub>BCKP</sub>		1.45		V
T <sub>opr</sub>	Operating temperature	-40		+85	°C

Table 12: General operating conditions

Symbol	Parameter	Min	Typical	Max	Unit
I <sub>leak</sub>	Leakage current input pins <sup>18</sup>		25		nA
V <sub>in</sub>	Input pin voltage range	0		V <sub>IO</sub>	V
V <sub>il</sub>	Low-level input voltage			0.63	V

<sup>15</sup> Exceeding the voltage ramp speed may permanently damage the device.

<sup>16</sup> The SAFEBOOT\_N pin has an internal 1 kΩ series resistor.

<sup>17</sup> At antenna feed point. Test conditions: source impedance = 50 Ω, continuous wave.

<sup>18</sup> V<sub>in</sub> = V<sub>IO</sub>, at room temperature.

Symbol	Parameter	Min	Typical	Max	Unit
$V_{ih}$	High-level input voltage	0.68 x $V_{IO}$			V
$V_{ol}$	Low-level output voltage, $I_{out} = -1 \text{ mA}$ <sup>19</sup>				0.4 V
$V_{oh}$	High-level output voltage, $I_{out} = 1 \text{ mA}$ <sup>19</sup>	$V_{IO} - 0.4$			V
$R_{pu, IO}$	Pull-up resistance, Digital IO <sup>20</sup>	8	18	40	k $\Omega$
$R_{pd, IO}$	Pull-down resistance, Digital IO	21	80	180	k $\Omega$
$R_{pu, SAFEBOOT\_N}$	Pull-up resistance, SAFEBOOT_N <sup>21</sup>	6	17	72	k $\Omega$
$R_{pu, RESET\_N}$	Pull-up resistance, RESET_N	7	10	13	k $\Omega$

**Table 13: Digital IO**

### 4.3 Indicative power requirements

This section provides examples of typical current requirements. They are characterized on samples using a cold start command. The actual power requirements may vary depending on the firmware version used, the external circuitry, the number of satellites tracked, the signal strength, the type and time of start, duration, internal LNA gain mode, and the test conditions.

All values in [Table 14](#), and [Table 15](#) have been measured at 25 °C ambient temperature with the default configuration unless otherwise stated. SBAS and QZSS are active in all measurements.

[Table 14](#) shows indicative current consumption for VCC and  $V_{IO}$  with a 3.0 V supply.

Symbol (Parameter)	Conditions	GPS	GPS+GAL	GPS+GAL +GLO	GPS+GAL +BDS B1C	GPS+GAL +BDS B1C +GLO (default)	Unit
$I_{VCC}$ <sup>22, 23</sup> (Current at VCC)	Acquisition <sup>24</sup>	8	10	12	11	13	mA
	Tracking (Continuous mode)	7.5	8	9	8.5	10	mA
	Tracking (Power save mode) <sup>25</sup>	4.5	5	5	-	-	mA
$I_{V_{IO}}$ <sup>22</sup> (Current at $V_{IO}$ )	Acquisition and Tracking (Continuous mode)	2.1	2.2	2.3	2.2	2.3	mA
	Tracking (Power save mode) <sup>25</sup>	2	2	2	-	-	mA

**Table 14: Typical currents for 3.0 V supply at VCC and  $V_{IO}$** 

The inrush current can go up to 100 mA at startup. Ensure that the external power supply is able to deliver up to 100 mA.

[Table 15](#) shows current consumption for the backup modes.

- <sup>19</sup> TIMEPULSE (PIO4) has 2 mA current drive/sink capability.  
<sup>20</sup> TXD, RXD, TIMEPULSE, EXTINT, SCL, and SDA.  
<sup>21</sup> The SAFEBOOT\_N pin has an additional 1 k $\Omega$  series resistor.  
<sup>22</sup> 1 Hz navigation update rate.  
<sup>23</sup> Simulated signal using power levels of -130 dBm.  
<sup>24</sup> Average current from start-up until the first fix.  
<sup>25</sup> Cyclic tracking operation. BeiDou B1C is not supported in this mode.

Symbol	Parameter	Conditions	Typ.	Unit
$I_{V\_BCKP}^{26}$	Total current in hardware backup mode	$V\_BCKP = 3.3\text{ V}, V\_IO = VCC = 0\text{ V}$	28	$\mu\text{A}$
$I_{V\_IO}$	$V\_IO$ current in software standby mode	$V\_IO = 3.3\text{ V}$	46	$\mu\text{A}$
$I_{VCC}$	VCC current in software standby mode	$VCC = 3.3\text{ V}$	120	nA

**Table 15: Backup currents**

Extreme operating temperatures can significantly impact the specified values. If an application operates near the min or max temperature limits, ensure the specified values are not exceeded.

<sup>26</sup>  $I_{V\_BCKP}$  current in normal operation ( $V\_BCKP = 3.3\text{ V}, V\_IO = VCC = 3.3\text{V}$ ) is  $\sim 3\ \mu\text{A}$ .

## 5 Communication interfaces

The receiver supports communication over the UART and I2C interfaces.

All the inputs have an internal pull-up resistor in normal operation and can be left open if not used. The voltage level at the PIO pins is related to the V<sub>IO</sub> supply voltage.

### 5.1 UART

The UART interface supports configurable baud rates. Hardware flow control is not supported. UART specifications are described in [Table 16](#).

Symbol	Parameter	Min	Max	Unit
R <sub>u</sub>	Baud rate	9600	921600	bit/s
Δ <sub>Tx</sub>	Tx baud rate accuracy	-1%	+1%	-
Δ <sub>Rx</sub>	Rx baud rate tolerance	-2.5%	+2.5%	-

Table 16: UART specifications

### 5.2 I2C

An I2C interface is available for communication with an external host CPU in the I2C Fast-mode. Backwards compatibility with the Standard-mode I2C bus operation is not supported. The interface can be operated only in the peripheral mode with a maximum clock frequency of 320 kHz<sup>27</sup>.

The interface can make use of clock stretching by holding the SCL line LOW to pause a transaction. In this case, the bit transfer rate is reduced. The maximum clock stretching time is 20 ms.

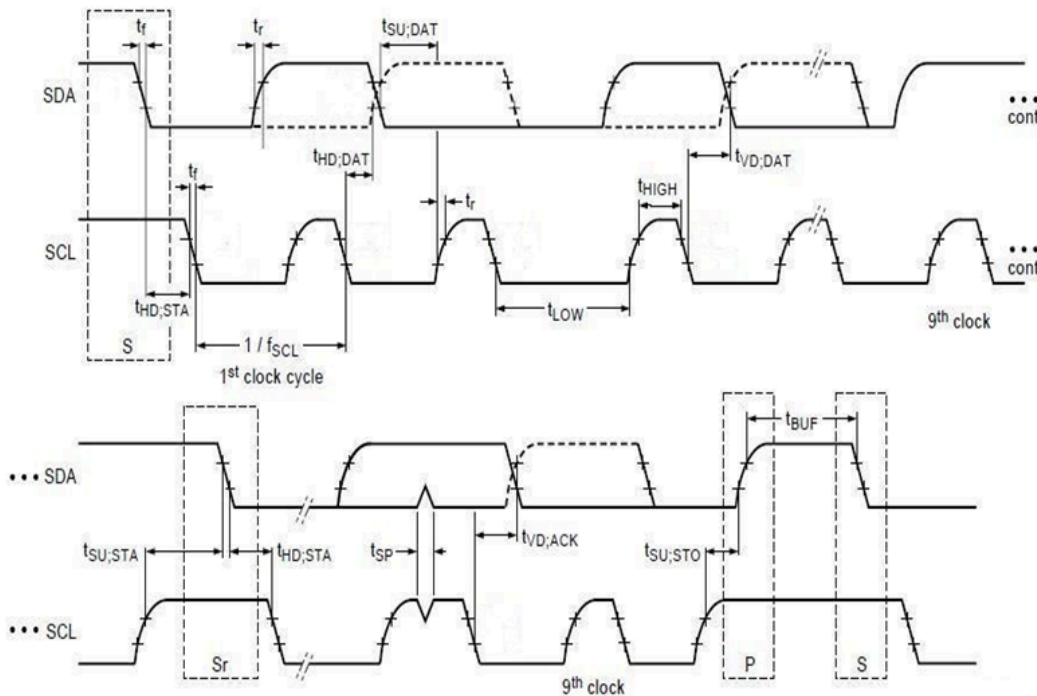

Figure 3: I2C peripheral specification

<sup>27</sup> External pull-up resistors may be needed to achieve 320 kbit/s communication speed, as the internal pull-up resistance can be very large.

Symbol	Parameter	I2C Fast-mode		Unit
		Min	Max	
$f_{SCL}$	SCL clock frequency	0	320	kHz
$t_{HD;STA}$	Hold time (repeated) START condition	0.6	-	$\mu$ s
$t_{LOW}$	Low period of the SCL clock	1.3	-	$\mu$ s
$t_{HIGH}$	High period of the SCL clock	0.6	-	$\mu$ s
$t_{SU;STA}$	Setup time for a repeated START condition	0.6	-	$\mu$ s
$t_{HD;DAT}$	Data hold time	0 <sup>28</sup>	- <sup>29</sup>	$\mu$ s
$t_{SU;DAT}$	Data setup time	100	-	ns
$t_r$	Rise time of both SDA and SCL signals	-	300 (for C = 400pF)	ns
$t_f$	Fall time of both SDA and SCL signals	-	300 (for C = 400pF)	ns
$t_{SU;STO}$	Setup time for STOP condition	0.6	-	$\mu$ s
$t_{BUF}$	Bus-free time between a STOP and START condition	1.3	-	$\mu$ s
$t_{VD;DAT}$	Data valid time	-	0.9 <sup>29</sup>	$\mu$ s
$t_{VD;ACK}$	Data valid acknowledge time	-	0.9 <sup>29</sup>	$\mu$ s
$V_{nL}$	Noise margin at the low level	0.1 V <sub>IO</sub>	-	V
$V_{nH}$	Noise margin at the high level	0.2 V <sub>IO</sub>	-	V

**Table 17: SAM-M10Q I2C peripheral timing and specifications**

## 5.3 Default interface settings

Interface	Settings
UART	<ul style="list-style-type: none"> <li>9600 baud, 8 bits, no parity bit, 1 stop bit.</li> <li>Input messages: NMEA and UBX.</li> <li>Output messages: NMEA GGA, GLL, GSA, GSV, RMC, VTG and TXT.</li> </ul>

**Table 18: Default interface settings**

<sup>28</sup> External device must provide a hold time of at least one transition time (max 300 ns) for the SDA signal (with respect to the min  $V_{ih}$  of the SCL signal) to bridge the undefined region of the falling edge of SCL.

<sup>29</sup> The maximum  $t_{HD;DAT}$  must be less than the maximum  $t_{VD;DAT}$  or  $t_{VD;ACK}$  with a maximum of 0.9  $\mu$ s by a transition time. This maximum must only be met if the device does not stretch the LOW period ( $t_{LOW}$ ) of the SCL signal. If the clock stretches the SCL, the data must be valid by the set-up time before it releases the clock.

## 6 Mechanical specifications

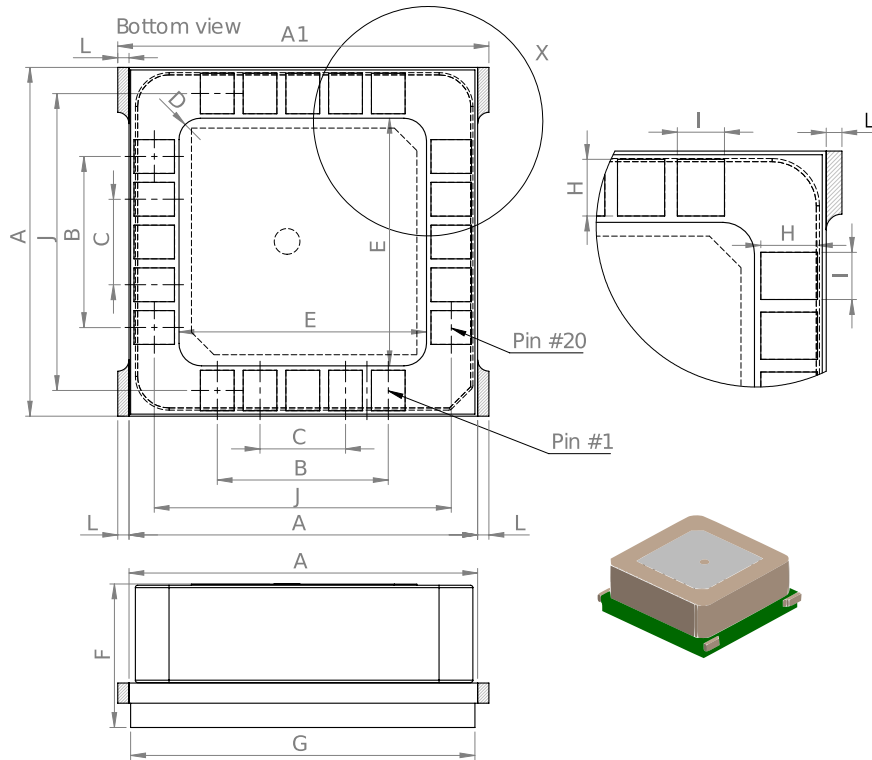

Figure 4: SAM-M10Q mechanical drawing

Symbol	Min (mm)	Typical (mm)	Max (mm)
A	15.4	15.5	15.6
A1	15.4	15.5	16.0
B	7.5	7.6	7.7
C	3.7	3.8	3.9
D	R0.9	R1.0	R1.1
E	10.9	11.1	11.3
F	5.8	6.3	6.8
G	15.0	15.3	15.6
H	1.6	1.7	1.9
I	1.4	1.5	1.6
J	13.1	13.2	13.3
L	0.0		0.3
Weight		5.6 g	

Table 19: SAM-M10Q mechanical dimensions



Take the size of the de-paneling residual tabs into account when designing the component keepout area.



## 7 Qualifications and approvals

<b>Quality and reliability</b>	
Product qualification	Qualified according to u-blox qualification policy, based on a subset of AEC-Q104
Manufacturing	Manufactured at ISO/TS 16949 certified sites
<b>Environmental</b>	
RoHS compliance	Yes
Moisture sensitivity level (MSL) <sup>30, 31</sup>	4
<b>Type approvals</b>	
European RED certification (CE)	Declaration of Conformity (DoC) is available on the <a href="#">u-blox website</a> .
UK conformity assessment (UKCA)	Yes

**Table 20: Qualifications and approvals**

<sup>30</sup> For MSL standard see IPC/JEDEC J-STD-020 and J-STD-033 [5].

<sup>31</sup> For more information regarding moisture sensitivity levels, labeling, storage, and drying, see the Product packaging reference guide [4].

## 8 Product handling

### 8.1 Soldering

Reflow soldering procedures are described in the IPC/JEDEC J-STD-020 standard [5].

## 9 Labeling and ordering information

This section provides information about product labeling and ordering.

### 9.1 Product labeling

The labeling of SAM-M10Q package provides product information and revision information. For more information, contact u-blox sales.

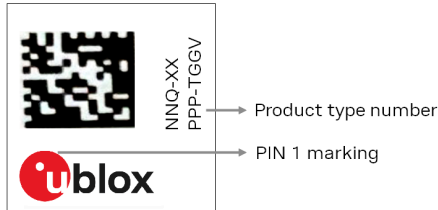

Figure 5: SAM-M10Q label

The parts of the product code are explained in [Table 21](#)

Code	Meaning	Example
PPP	Product family	SAM
TGG	Platform	M10 = u-blox M10
V	Variant	Q = Standard precision, ROM, TCXO, SAW filter, and LNA
NN	Option	00, 01, 02, ...
Q	Quality grade	A = Automotive, B = Professional
XX	Product detail	Describes hardware and firmware versions

Table 21: Part identification code

### 9.2 Explanation of product codes

Three product code formats are used in the product label. The product name is used in documentation such as this data sheet and identifies all u-blox products, independent of packaging and quality grade. The ordering code includes options and quality, while the type number includes the hardware and firmware versions.

[Table 22](#) describes the three different product code formats used in the SAM-M10Q module.

Format	Structure	Product code
Product name	PPP-TGGV	SAM-M10Q
Ordering code	PPP-TGGV-NNQ	SAM-M10Q-00B
Type number	PPP-TGGV-NNQ-XX	SAM-M10Q-00B-01

Table 22: Product code formats

### 9.3 Ordering codes

Ordering code	Product	Remark
SAM-M10Q-00B	u-blox SAM-M10Q GNSS antenna module, professional grade	

Table 23: Product ordering codes



Product changes affecting form, fit or function are documented by u-blox. For a list of Product Change Notifications (PCNs) see our website at: <https://www.u-blox.com/en/product-resources>.

## Related documents

- [1] SAM-M10Q Integration manual, [UBX-22020019](#)
- [2] u-blox M10 SPG 5.10 Release notes, [UBX-22001426](#)
- [3] u-blox M10 SPG 5.10 Interface description, [UBX-21035062](#)
- [4] Product packaging reference guide, [UBX-14001652](#)
- [5] Joint IPC/JEDEC standard, [www.jedec.org](http://www.jedec.org)



For regular updates to u-blox documentation and to receive product change notifications please register on our homepage <https://www.u-blox.com>.

## Revision history

Revision	Date	Comments
R01	27-Jun-2022	Initial release
R02	20-Jul-2022	Engineering sample. Updated sections Performance, Mechanical specifications, and Related documents.
R03	30-Aug-2022	Initial production.
R04	19-May-2023	Updated maximum navigation update rate in section Performance. Added 1 Hz navigation update rate footnote in section Indicative power requirements.
R05	08-Apr-2024	Mass production Added section <ul style="list-style-type: none"><li>• Product handling: Soldering</li></ul> Updated sections <ul style="list-style-type: none"><li>• Supported GNSS constellations: Supported Assisted GNSS (A-GNSS) services</li><li>• Pin assignment</li><li>• Pin state</li><li>• Communication interfaces</li><li>• Mechanical specifications</li><li>• Qualifications and approvals</li></ul> Change in document structure <ul style="list-style-type: none"><li>• Moisture sensitivity level (MSL) included in chapter Qualifications and approvals</li></ul>

## Contact

### u-blox AG

Address: Zürcherstrasse 68  
8800 Thalwil  
Switzerland

For further support and contact information, visit us at [www.u-blox.com/support](http://www.u-blox.com/support).