

PKJ 4000E series Direct Converters
 Input 36-75 V, Output up to 30 A / 100 W

EN/LZT 146 383 R4A September 2011

© Ericsson AB

Key Features

- Industry standard Half-brick
 58 x 61 x 8.5 mm (2.3 x 2.4 x 0.33 in.)
- High efficiency, typ. 92 % at 3.3 Vout half load
- 1500 Vdc input to output isolation
- Meets isolation requirements equivalent to basic insulation according to IEC/EN/UL 60950
- More than 3.7 million hours MTBF



General Characteristics

- Suited for narrow board pitch applications (15 mm/0.6 in)
- Output over voltage protection
- Input under voltage shutdown
- Over temperature protection
- Monotonic start-up
- Output short-circuit protection
- Remote sense
- Remote control
- Output voltage adjust function
- Highly automated manufacturing ensures quality
- ISO 9001/14001 certified supplier

Safety Approvals



Design for Environment



Meets requirements in high-temperature lead-free soldering processes.

Contents

Ordering Information	2
General Information	2
Safety Specification	3
Absolute Maximum Ratings	4
Electrical Specification	
1.8 V, 36 A / 65 W	PKJ 4618GE PI 5
2.5 V, 30 A / 75 W	PKJ 4719E PI 9
3.3 V, 25 A / 82.5 W	PKJ 4810E PI 13
3.3 V, 30 A / 100 W	PKJ 4110E PI 17
5.0 V, 20 A / 100 W	PKJ 4111E PI 21
12 V, 8.3 A / 100 W	PKJ 4113E PI 25
EMC Specification	29
Operating Information	30
Thermal Consideration	31
Connections	33
Mechanical Information	34
Soldering Information	36
Delivery Information	36
Product Qualification Specification	37

PKJ 4000E series Direct Converters
Input 36-75 V, Output up to 30 A / 100 W

EN/LZT 146 383 R4A September 2011

© Ericsson AB

Ordering Information

Product program	Output
PKJ 4618GE	1.8 V, 36 A / 65 W
PKJ 4719E	2.5 V, 30 A / 75 W
PKJ 4810E	3.3 V, 25 A / 82.5 W
PKJ 4110E	3.3 V, 30 A / 100 W
PKJ 4111E	5.0 V, 20 A / 100 W
PKJ 4113E	12 V, 8.3 A / 100 W

Product number and Packaging

PKJ 4XXXEPI n ₁ n ₂ n ₃ n ₄				
Options	n ₁	n ₂	n ₃	n ₄
Positive Remote Control logic	o			
Baseplate		o		
Lead length			o	
Delivery package information				o

Options	Description
n ₁	Negative Remote Control logic* P Positive Remote Control logic
n ₂	Open Frame * HS Baseplate
n ₃	5.30 mm * LA 3.69 mm
n ₄	Tray

As an example a positive logic, baseplate, short pin product with tray packaging would be PKJ 4110E PIPHSLA.

* Standard variant (i.e. no option selected).

General Information

Reliability

The failure rate (λ) and mean time between failures (MTBF= 1/ λ) is calculated at max output power and an operating ambient temperature (T_A) of +40°C. Ericsson Power Modules uses Telcordia SR-332 Issue 2 Method 1 to calculate the mean steady-state failure rate and standard deviation (σ).

Telcordia SR-332 Issue 2 also provides techniques to estimate the upper confidence levels of failure rates based on the mean and standard deviation.

Mean steady-state failure rate, λ	Std. deviation, σ
271 nFailures/h	38.6 nFailures/h

MTBF (mean value) for the PKJ-E series = 3.7 Mh.
MTBF at 90% confidence level = 3.1 Mh

Compatibility with RoHS requirements

The products are compatible with the relevant clauses and requirements of the RoHS directive 2002/95/EC and have a maximum concentration value of 0.1% by weight in

homogeneous materials for lead, mercury, hexavalent chromium, PBB and PBDE and of 0.01% by weight in homogeneous materials for cadmium.

Exemptions in the RoHS directive utilized in Ericsson Power Modules products are found in the Statement of Compliance document.

Ericsson Power Modules fulfills and will continuously fulfill all its obligations under regulation (EC) No 1907/2006 concerning the registration, evaluation, authorization and restriction of chemicals (REACH) as they enter into force and is through product materials declarations preparing for the obligations to communicate information on substances in the products.

Quality Statement

The products are designed and manufactured in an industrial environment where quality systems and methods like ISO 9000, Six Sigma, and SPC are intensively in use to boost the continuous improvements strategy. Infant mortality or early failures in the products are screened out and they are subjected to an ATE-based final test. Conservative design rules, design reviews and product qualifications, plus the high competence of an engaged work force, contribute to the high quality of the products.

Warranty

Warranty period and conditions are defined in Ericsson Power Modules General Terms and Conditions of Sale.

Limitation of Liability

Ericsson Power Modules does not make any other warranties, expressed or implied including any warranty of merchantability or fitness for a particular purpose (including, but not limited to, use in life support applications, where malfunctions of product can cause injury to a person's health or life).

© Ericsson AB 2011

The information and specifications in this technical specification is believed to be correct at the time of publication. However, no liability is accepted for inaccuracies, printing errors or for any consequences thereof. Ericsson AB reserves the right to change the contents of this technical specification at any time without prior notice.

PKJ 4000E series Direct Converters
Input 36-75 V, Output up to 30 A / 100 W

EN/LZT 146 383 R4A September 2011

© Ericsson AB

Safety Specification

General information

Ericsson Power Modules DC/DC converters and DC/DC regulators are designed in accordance with safety standards IEC/EN/UL 60950-1 *Safety of Information Technology Equipment*.

IEC/EN/UL 60950-1 contains requirements to prevent injury or damage due to the following hazards:

- Electrical shock
- Energy hazards
- Fire
- Mechanical and heat hazards
- Radiation hazards
- Chemical hazards

On-board DC/DC converters and DC/DC regulators are defined as component power supplies. As components they cannot fully comply with the provisions of any safety requirements without "Conditions of Acceptability". Clearance between conductors and between conductive parts of the component power supply and conductors on the board in the final product must meet the applicable safety requirements. Certain conditions of acceptability apply for component power supplies with limited stand-off (see Mechanical Information for further information). It is the responsibility of the installer to ensure that the final product housing these components complies with the requirements of all applicable safety standards and regulations for the final product.

Component power supplies for general use should comply with the requirements in IEC 60950-1, EN 60950-1 and UL 60950-1 *Safety of Information Technology Equipment*. There are other more product related standards, e.g. IEEE 802.3 *CSMA/CD (Ethernet) Access Method*, and ETS-300132-2 *Power supply interface at the input to telecommunications equipment, operated by direct current (dc)*, but all of these standards are based on IEC/EN/UL 60950-1 with regards to safety.

Ericsson Power Modules DC/DC converters and DC/DC regulators are UL 60950-1 recognized and certified in accordance with EN 60950-1.

The flammability rating for all construction parts of the products meet requirements for V-0 class material according to IEC 60695-11-10, *Fire hazard testing, test flames* – 50 W horizontal and vertical flame test methods.

The products should be installed in the end-use equipment, in accordance with the requirements of the ultimate application. Normally the output of the DC/DC converter is considered as SELV (Safety Extra Low Voltage) and the input source must be isolated by minimum or Reinforced Insulation from the primary circuit (AC mains) in accordance with IEC/EN/UL 60950-1.

Isolated DC/DC converters

It is recommended that a slow blow fuse is to be used at the input of each DC/DC converter. If an input filter is used in the circuit the fuse should be placed in front of the input filter.

In the rare event of a component problem that imposes a short circuit on the input source, this fuse will provide the following functions:

- Isolate the fault from the input power source so as not to affect the operation of other parts of the system.
- Protect the distribution wiring from excessive current and power loss thus preventing hazardous overheating.

The galvanic isolation is verified in an electric strength test. The test voltage (V_{iso}) between input and output is 1500 Vdc or 2250 Vdc (refer to product specification).

24 V DC systems

The input voltage to the DC/DC converter is SELV (Safety Extra Low Voltage) and the output remains SELV under normal and abnormal operating conditions.

48 and 60 V DC systems

If the input voltage to the DC/DC converter is 75 Vdc or less, then the output remains SELV (Safety Extra Low Voltage) under normal and abnormal operating conditions.

Single fault testing in the input power supply circuit should be performed with the DC/DC converter connected to demonstrate that the input voltage does not exceed 75 Vdc.

If the input power source circuit is a DC power system, the source may be treated as a TNV-2 circuit and testing has demonstrated compliance with SELV limits in accordance with IEC/EN/UL60950-1.

Non-isolated DC/DC regulators

The input voltage to the DC/DC regulator is SELV (Safety Extra Low Voltage) and the output remains SELV under normal and abnormal operating conditions.

PKJ 4000E series Direct Converters
 Input 36-75 V, Output up to 30 A / 100 W

EN/LZT 146 383 R4A September 2011

© Ericsson AB

Absolute Maximum Ratings

Characteristics		min	typ	max	Unit
T_{P1}	Operating Temperature (see Thermal Consideration section)	-40		+125	°C
T_S	Storage temperature	-55		+125	°C
V_I	Input voltage	-0.5		+80	V
V_{iso}	Isolation voltage (input to output test voltage)			1500	Vdc
V_{tr}	Input voltage transient (t_p 100 ms)			100	V
V_{RC}	Remote Control pin voltage (see Operating Information section)	Positive logic option		6	V
		Negative logic option	0.5	75	V
V_{adj}	Adjust pin voltage (see Operating Information section)	-0.5		$2 \times V_{oi}$	V

Stress in excess of Absolute Maximum Ratings may cause permanent damage. Absolute Maximum Ratings, sometimes referred to as no destruction limits, are normally tested with one parameter at a time exceeding the limits in the Electrical Specification. If exposed to stress above these limits, function and performance may degrade in an unspecified manner.

Fundamental Circuit Diagram

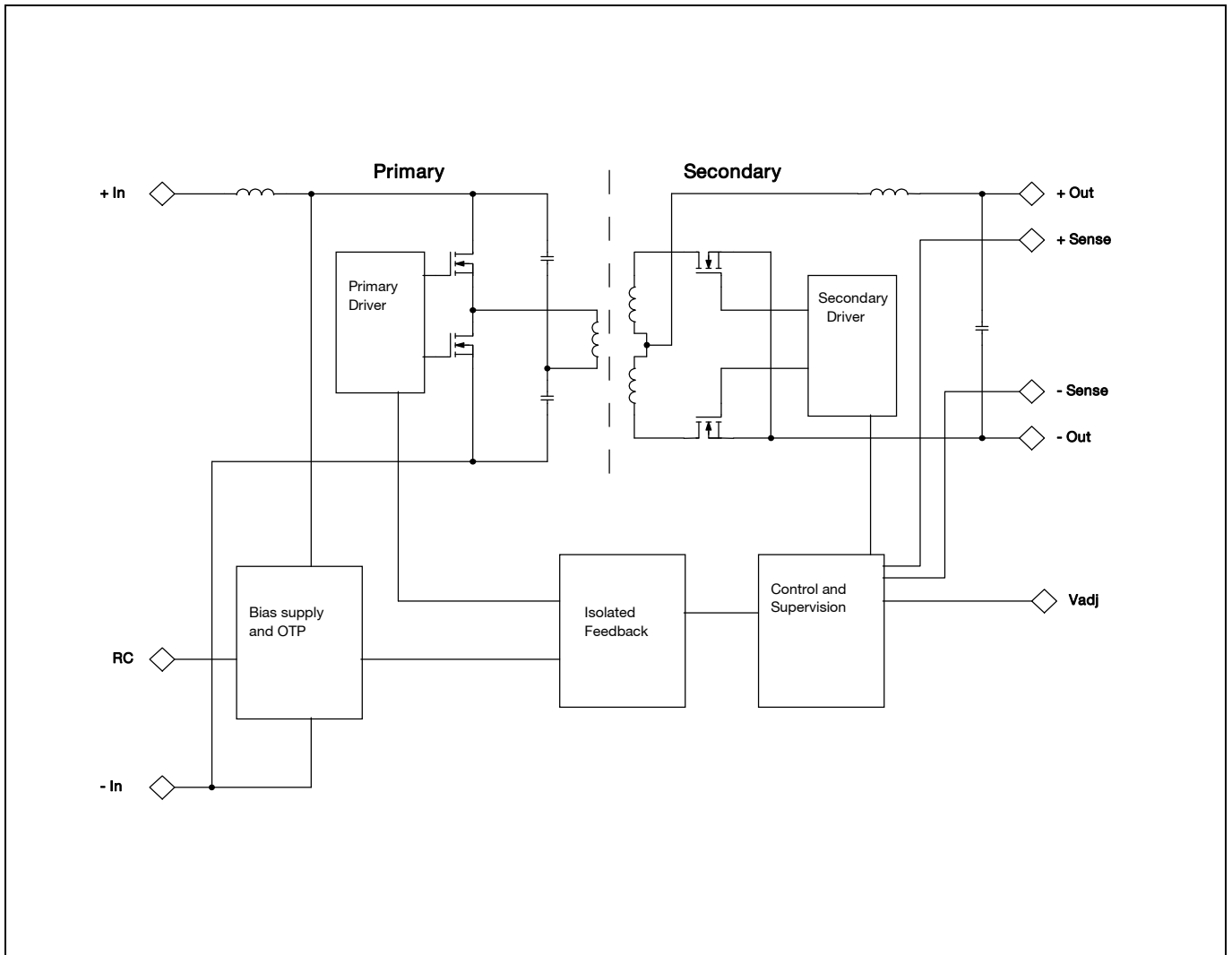

PKJ 4000E series Direct Converters
 Input 36-75 V, Output up to 30 A / 100 W

EN/LZT 146 383 R4A September 2011

© Ericsson AB

Electrical Specification
1.8 V, 36 A / 65 W
PKJ 4618GE PI
 $T_{P1} = -40$ to $+90^{\circ}\text{C}$, $V_I = 36$ to 75 V, sense pins connected to output pins unless otherwise specified under Conditions.

 Typical values given at: $T_{P1} = +25^{\circ}\text{C}$, $V_I = 53$ V, I_O max, unless otherwise specified under Conditions.

Characteristics		Conditions	min	typ	max	Unit
V_I	Input voltage range		36		75	V
V_{Ioff}	Turn-off input voltage	Decreasing input voltage	31	32	34	V
V_{Ion}	Turn-on input voltage	Increasing input voltage	33	34	36	V
C_I	Internal input capacitance			6.4		μF
P_O	Output power		0		65	W
η	Efficiency	50% of max I_O		90		%
		max I_O		87.5		
		50% of max I_O , $V_I = 48$ V		90.5		
		max I_O , $V_I = 48$ V		87.5		
P_d	Power Dissipation	max I_O		9	12	W
P_{li}	Input idling power	$I_O = 0$ A, $V_I = 53$ V		1.5		W
P_{RC}	Input standby power	$V_I = 53$ V (turned off with RC)		0.25		W
f_s	Switching frequency	100 % of max I_O	125	140	155	kHz

V_{Oi}	Output voltage initial setting and accuracy	$T_{P1} = +25^{\circ}\text{C}$, $V_I = 53$ V, $I_O = 36$ A	1.77	1.80	1.83	V
V_O	Output adjust range	See operating information	1.62		1.98	V
	Output voltage tolerance band	0-100% of max I_O	1.75		1.85	V
	Idling voltage	$I_O = 0$ A	1.77		1.83	V
	Line regulation	max I_O		1	5	mV
	Load regulation	$V_I = 53$ V, 0-100% of max I_O		2	10	mV
V_{tr}	Load transient voltage deviation	$V_I = 53$ V, Load step 25-75-25% of max I_O , $di/dt = 1$ A/ μs		± 250	± 350	mV
t_{tr}	Load transient recovery time			40	60	μs
t_r	Ramp-up time (from 10-90% of V_{Oi})	10-100% of max I_O	8	15	30	ms
t_s	Start-up time (from V_I connection to 90% of V_{Oi})		12	20	40	ms
t_f	V_I shut-down fall time (from V_I off to 10% of V_O)	max I_O		0.1		ms
		$I_O = 0$ A		10		s
t_{RC}	RC start-up time	max I_O		20		ms
	RC shut-down fall time (from RC off to 10% of V_O)	max I_O		0.15		ms
		$I_O = 0$ A		10		s
I_O	Output current		0		36	A
I_{lim}	Current limit threshold	$T_{P1} < \text{max } T_{P1}$	39	43	58	A
I_{sc}	Short circuit current	$T_{P1} = 25^{\circ}\text{C}$, see Note 1		48	60	A
C_{out}	Recommended Capacitive Load	$T_{P1} = 25^{\circ}\text{C}$, see Note 2	0		10000	μF
V_{Oac}	Output ripple & noise	See ripple & noise section, V_{Oi}		150	200	mVp-p
OVP	Over voltage protection	$T_{P1} = +25^{\circ}\text{C}$, $V_I = 53$ V, 0-100% of max I_O	2.0	2.5	3.0	V

Note 1: See Operating Information section

Note 2: Cout: OSCON type and ESR<5 mohm

PKJ 4000E series Direct Converters
 Input 36-75 V, Output up to 30 A / 100 W

EN/LZT 146 383 R4A September 2011

© Ericsson AB

Typical Characteristics
1.8 V, 36 A / 65 W

PKJ 4618GE PI

Efficiency

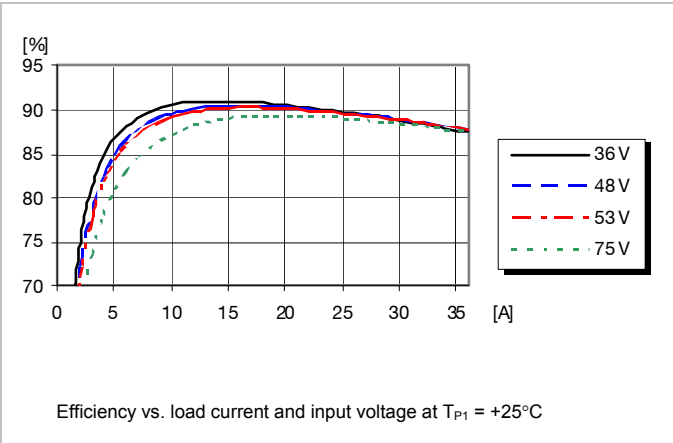

Power Dissipation

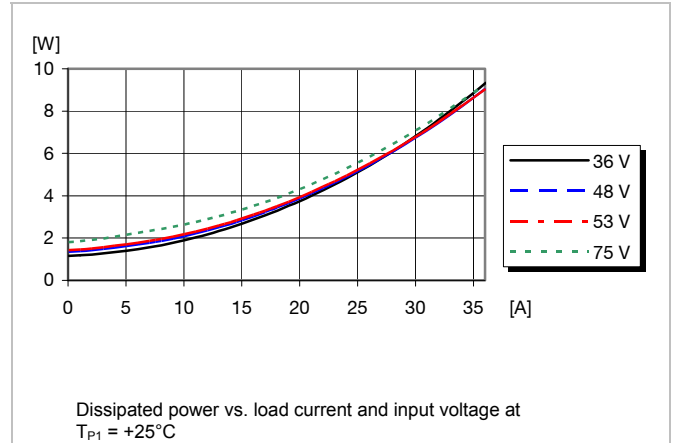

Output Characteristics

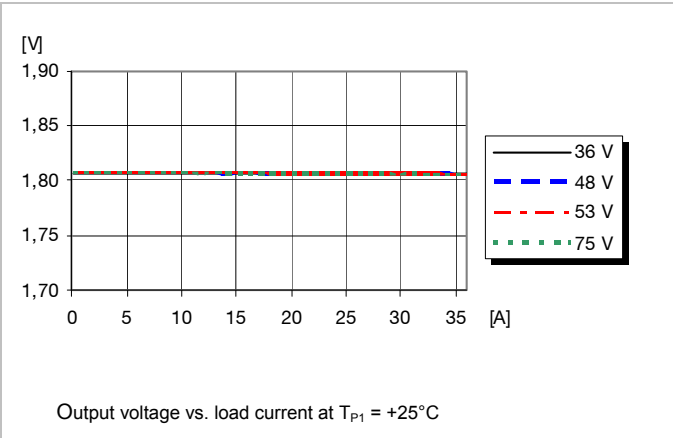

PKJ 4000E series Direct Converters
 Input 36-75 V, Output up to 30 A / 100 W

EN/LZT 146 383 R4A September 2011

© Ericsson AB

Typical Characteristics
1.8 V, 36 A / 65 W

PKJ 4618GE PI

Start-up

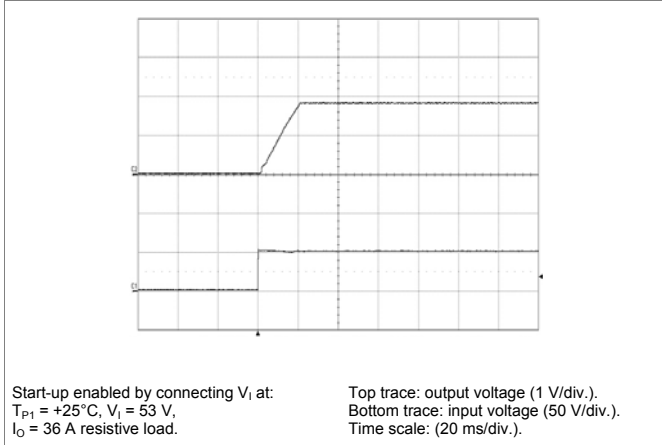

Shut-down

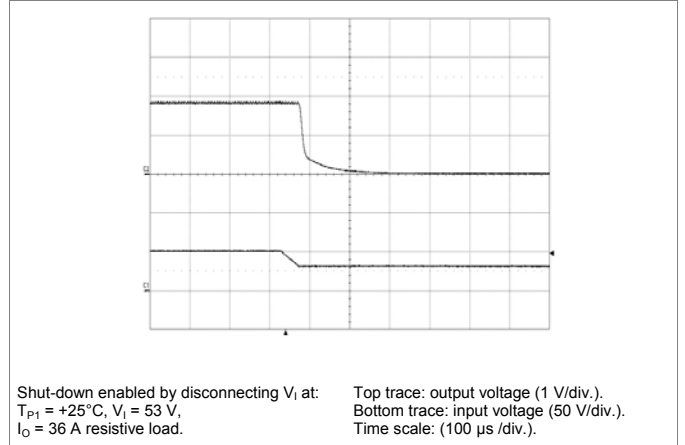

Output Ripple & Noise

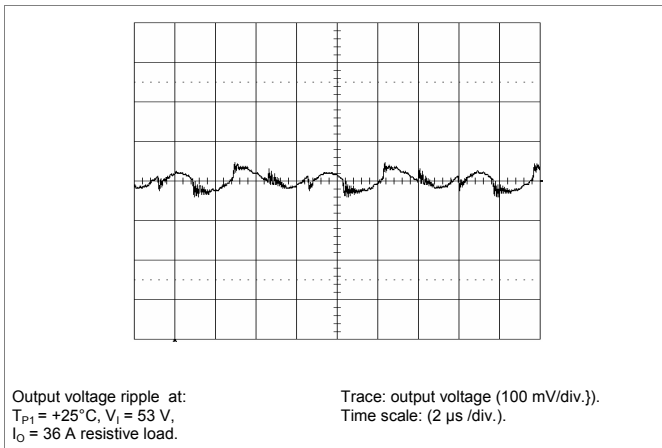

Output Load Transient Response

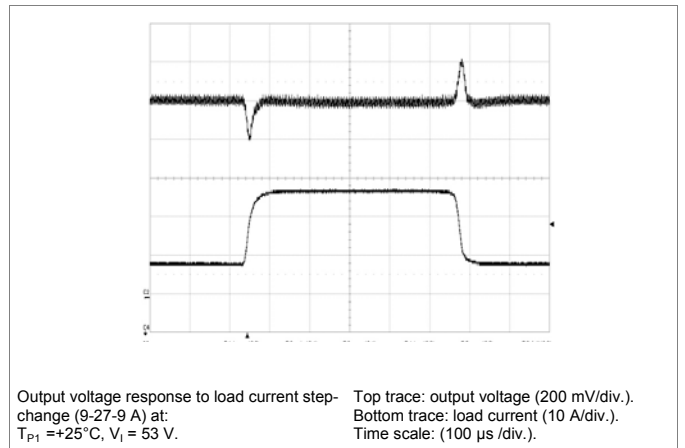

Output Voltage Adjust (see operating information)

Passive adjust

The resistor value for an adjusted output voltage is calculated by using the following equations:

Output Voltage Adjust, Decrease:

$$R_{adj} = \left[\frac{100}{\Delta\%} - 2 \right] \text{ k}\Omega$$

Example: Decrease 2% $\Rightarrow V_{out} = 1.76\text{ Vdc}$

$$\left[\frac{100}{2} - 2 \right] = 48\text{ k}\Omega$$

Output Voltage Adjust, Increase:

$$R_{adj} = \left[\frac{1.8(100 + \Delta\%)}{1.225\Delta\%} - \frac{100 + 2\Delta\%}{\Delta\%} \right] \text{ k}\Omega$$

Example: Increase 4% $\Rightarrow V_{out} = 1.87\text{ Vdc}$

$$\left[\frac{1.8(100 + 4)}{1.225 \times 4} - \frac{100 + 2 \times 4}{4} \right] = 11.2\text{ k}\Omega$$

PKJ 4000E series Direct Converters
 Input 36-75 V, Output up to 30 A / 100 W

EN/LZT 146 383 R4A September 2011

© Ericsson AB

Typical Characteristics
1.8 V, 36 A / 65 W

PKJ 4618GE PI

Output Current Derating – Open frame

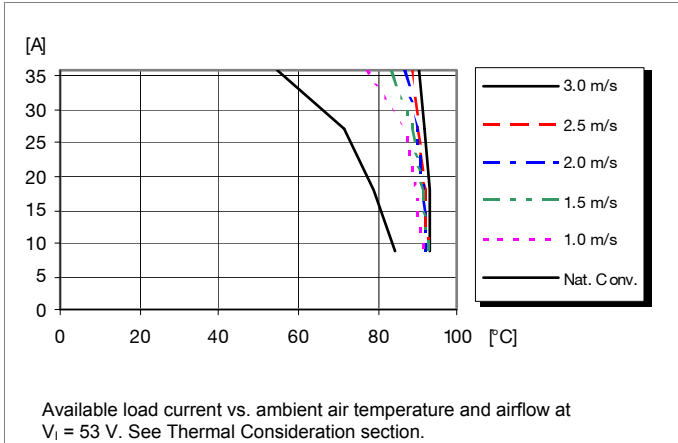

Output Current Derating – Base plate

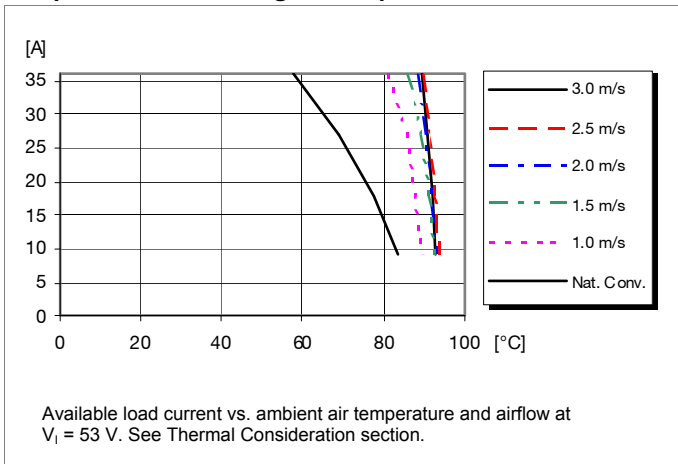

Thermal Resistance – Base plate

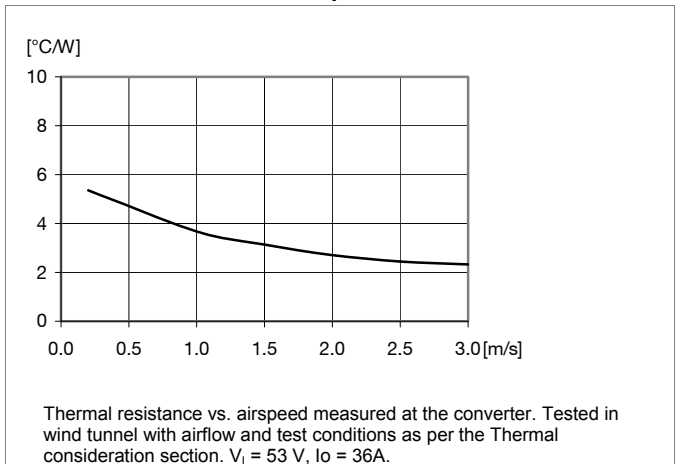

PKJ 4000E series Direct Converters
 Input 36-75 V, Output up to 30 A / 100 W

EN/LZT 146 383 R4A September 2011

© Ericsson AB

Electrical Specification
PKJ 4719E PI
2.5 V, 30 A / 75 W
 $T_{P1} = -40$ to $+90^{\circ}\text{C}$, $V_I = 36$ to 75 V, sense pins connected to output pins unless otherwise specified under Conditions.

 Typical values given at: $T_{P1} = +25^{\circ}\text{C}$, $V_I = 53$ V, I_O max, unless otherwise specified under Conditions.

Characteristics		Conditions	min	typ	max	Unit
V_I	Input voltage range		36		75	V
V_{Ioff}	Turn-off input voltage	Decreasing input voltage	31	32	34	V
V_{Ion}	Turn-on input voltage	Increasing input voltage	33	34	36	V
C_I	Internal input capacitance			6.4		μF
P_O	Output power		0		75	W
η	Efficiency	50% of max I_O		90		%
		max I_O		87		
		50% of max I_O , $V_I = 48$ V		90.5		
		max I_O , $V_I = 48$ V		87		
P_d	Power Dissipation	max I_O		11.5	16.5	W
P_{li}	Input idling power	$I_O = 0$ A, $V_I = 53$ V		1.5		W
P_{RC}	Input standby power	$V_I = 53$ V (turned off with RC)		0.25		W
f_s	Switching frequency	100 % of max I_O	125	140	155	kHz

V_{Oi}	Output voltage initial setting and accuracy	$T_{P1} = +25^{\circ}\text{C}$, $V_I = 53$ V, $I_O = 30$ A	2.45	2.50	2.55	V
V_O	Output adjust range	See operating information	2.00		2.75	V
	Output voltage tolerance band	0-100% of max I_O	2.42		2.58	V
	Idling voltage	$I_O = 0$ A	2.45		2.55	V
	Line regulation	max I_O		0.2	5	mV
	Load regulation	$V_I = 53$ V, 0-100% of max I_O		0.2	5	mV
V_{tr}	Load transient voltage deviation	$V_I = 53$ V, Load step 25-75-25% of max I_O , $di/dt = 1$ A/ μs		± 200	± 470	mV
t_{tr}	Load transient recovery time			35	60	μs
t_r	Ramp-up time (from 10-90% of V_{Oi})	10-100% of max I_O	4	15	30	ms
t_s	Start-up time (from V_I connection to 90% of V_{Oi})		7	20	40	ms
t_f	V_I shut-down fall time (from V_I off to 10% of V_O)	max I_O		0.15		ms
		$I_O = 0$ A		13		s
t_{RC}	RC start-up time	max I_O		12		ms
	RC shut-down fall time (from RC off to 10% of V_O)	max I_O		0.18		ms
		$I_O = 0$ A		13		s
I_O	Output current		0		30	A
I_{lim}	Current limit threshold	$T_{P1} < \text{max } T_{P1}$	31	33	40	A
I_{sc}	Short circuit current	$T_{P1} = 25^{\circ}\text{C}$, see Note 1		40	45	A
C_{out}	Recommended Capacitive Load	$T_{P1} = 25^{\circ}\text{C}$, see Note 2	0		10000	μF
V_{Oac}	Output ripple & noise	See ripple & noise section, V_{Oi}		150	200	mVp-p
OVP	Over voltage protection	$T_{P1} = +25^{\circ}\text{C}$, $V_I = 53$ V, 0-100% of max I_O	3.0	3.5	4.0	V

Note 1: See Operating Information section

Note 2: Cout: OSCON type and ESR<5 mohm

PKJ 4000E series Direct Converters
 Input 36-75 V, Output up to 30 A / 100 W

EN/LZT 146 383 R4A September 2011

© Ericsson AB

Typical Characteristics
2.5 V, 30 A / 75 W

PKJ 4719E PI

Efficiency

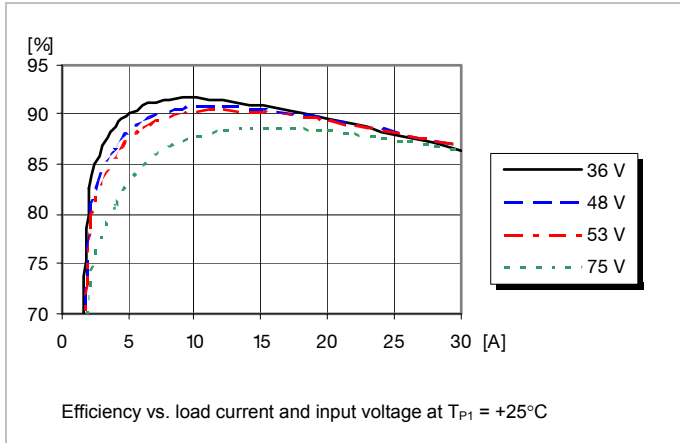

Power Dissipation

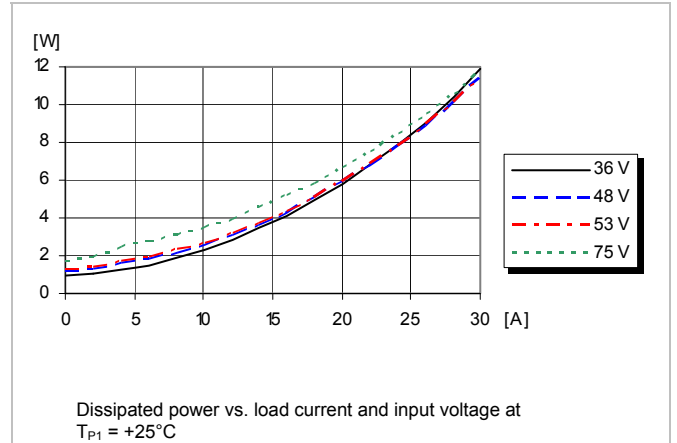

Output Characteristics

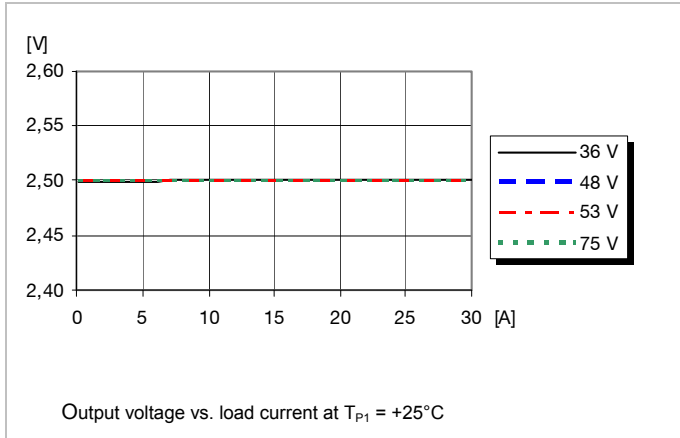

PKJ 4000E series Direct Converters
 Input 36-75 V, Output up to 30 A / 100 W

EN/LZT 146 383 R4A September 2011

© Ericsson AB

Typical Characteristics
2.5 V, 30 A / 75 W

PKJ 4719E PI

Start-up

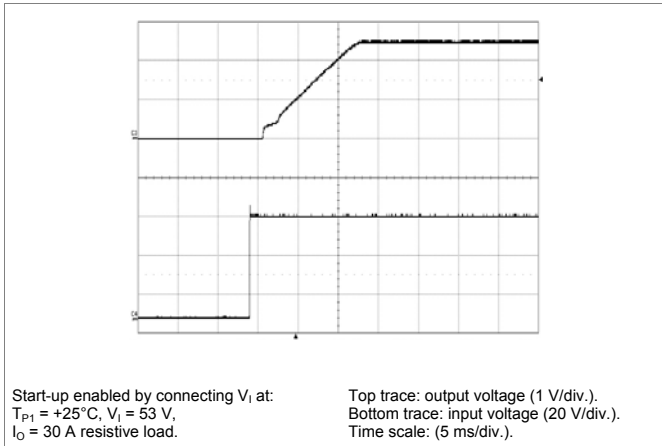

Shut-down

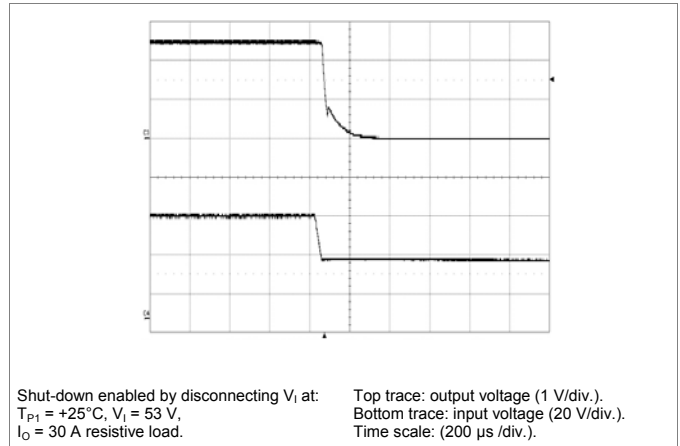

Output Ripple & Noise

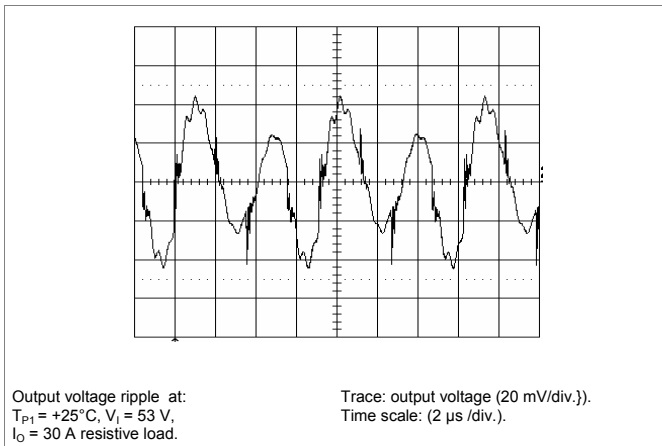

Output Load Transient Response

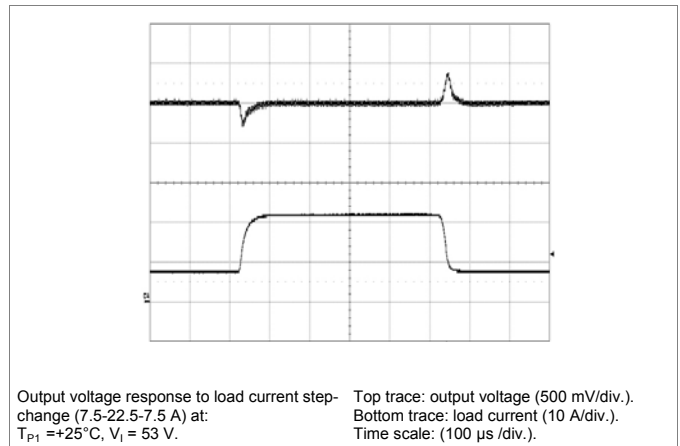

Output Voltage Adjust (see operating information)

Passive adjust

The resistor value for an adjusted output voltage is calculated by using the following equations:

Output Voltage Adjust, Decrease:

$$R_{adj} = \left[\frac{100}{\Delta\%} - 2 \right] \text{ k}\Omega$$

Example: Decrease 2% $\Rightarrow V_{out} = 2.45\text{ Vdc}$

$$\left[\frac{100}{2} - 2 \right] = 48\text{ k}\Omega$$

Output Voltage Adjust, Increase:

$$R_{adj} = \left[\frac{2.5(100 + \Delta\%)}{1.225\Delta\%} - \frac{100 + 2\Delta\%}{\Delta\%} \right] \text{ k}\Omega$$

Example: Increase 4% $\Rightarrow V_{out} = 2.60\text{ Vdc}$

$$\left[\frac{2.5(100 + 4)}{1.225 \times 4} - \frac{100 + 2 \times 4}{4} \right] = 26.1\text{ k}\Omega$$

PKJ 4000E series Direct Converters
 Input 36-75 V, Output up to 30 A / 100 W

EN/LZT 146 383 R4A September 2011

© Ericsson AB

Typical Characteristics
2.5 V, 30 A / 75 W

PKJ 4719E PI

Output Current Derating – Open frame

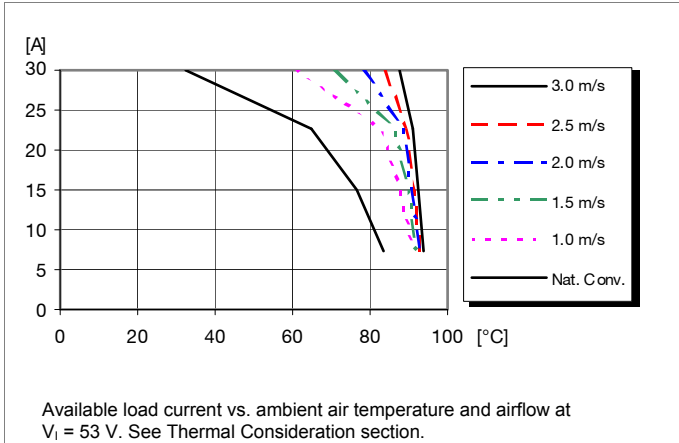

Output Current Derating – Base plate

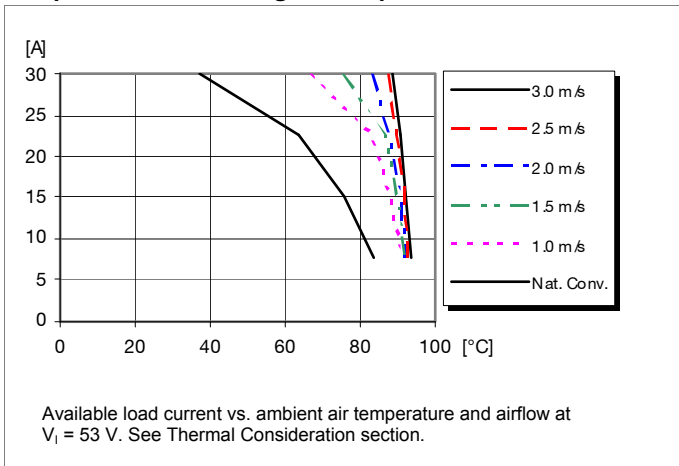

Thermal Resistance – Base plate

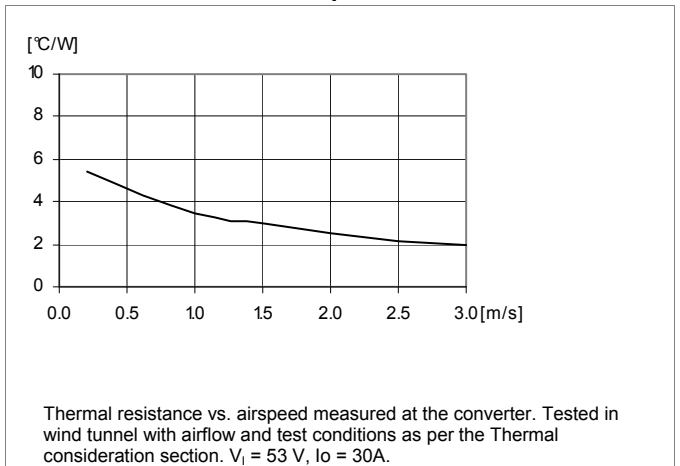

PKJ 4000E series Direct Converters
 Input 36-75 V, Output up to 30 A / 100 W

EN/LZT 146 383 R4A September 2011

© Ericsson AB

Electrical Specification
PKJ 4810E PI
3.3 V, 25 A / 82.5 W
 $T_{P1} = -40$ to $+90^{\circ}\text{C}$, $V_I = 36$ to 75 V, sense pins connected to output pins unless otherwise specified under Conditions.

 Typical values given at: $T_{P1} = +25^{\circ}\text{C}$, $V_I = 53$ V, I_O max, unless otherwise specified under Conditions.

Characteristics		Conditions	min	typ	max	Unit
V_I	Input voltage range		36		75	V
V_{Ioff}	Turn-off input voltage	Decreasing input voltage	31	32	34	V
V_{Ion}	Turn-on input voltage	Increasing input voltage	33	34	36	V
C_I	Internal input capacitance			6.4		μF
P_O	Output power		0		82.5	W
η	Efficiency	50% of max I_O		92.5		%
		max I_O		90		
		50% of max I_O , $V_I = 48$ V		92.5		
		max I_O , $V_I = 48$ V		90		
P_d	Power Dissipation	max I_O		9.2	13	W
P_{li}	Input idling power	$I_O = 0$ A, $V_I = 53$ V		1.5		W
P_{RC}	Input standby power	$V_I = 53$ V (turned off with RC)		0.25		W
f_s	Switching frequency	100 % of max I_O	125	140	155	kHz

V_{Oi}	Output voltage initial setting and accuracy	$T_{P1} = +25^{\circ}\text{C}$, $V_I = 53$ V, $I_O = 30$ A	3.23	3.30	3.37	V
V_O	Output adjust range	See operating information	2.64		3.63	V
	Output voltage tolerance band	0-100% of max I_O	3.20		3.40	V
	Idling voltage	$I_O = 0$ A	3.23		3.37	V
	Line regulation	max I_O		0.5	5	mV
	Load regulation	$V_I = 53$ V, 0-100% of max I_O		0.5	5	mV
V_{tr}	Load transient voltage deviation	$V_I = 53$ V, Load step 25-75-25% of max I_O , $di/dt = 1$ A/ μs		± 300	± 420	mV
t_{tr}	Load transient recovery time			35	60	μs
t_r	Ramp-up time (from 10-90% of V_{Oi})	10-100% of max I_O	9	15	30	ms
t_s	Start-up time (from V_I connection to 90% of V_{Oi})		12	20	40	ms
t_f	V_I shut-down fall time (from V_I off to 10% of V_O)	max I_O		0.22		ms
		$I_O = 0$ A		17		s
t_{RC}	RC start-up time	max I_O		17		ms
	RC shut-down fall time (from RC off to 10% of V_O)	max I_O		0.24		ms
		$I_O = 0$ A		17		s
I_O	Output current		0		25	A
I_{lim}	Current limit threshold	$T_{P1} < \text{max } T_{P1}$	26	29	35	A
I_{sc}	Short circuit current	$T_{P1} = 25^{\circ}\text{C}$, see Note 1		35	40	A
C_{out}	Recommended Capacitive Load	$T_{P1} = 25^{\circ}\text{C}$, see Note 2	0		10000	μF
V_{Oac}	Output ripple & noise	See ripple & noise section, V_{Oi}		75	120	mVp-p
OVP	Over voltage protection	$T_{P1} = +25^{\circ}\text{C}$, $V_I = 53$ V, 0-100% of max I_O	3.9	5	6.0	V

Note 1: See Operating Information section

Note 2: Cout: OSCON type and ESR<5 mohm

PKJ 4000E series Direct Converters
 Input 36-75 V, Output up to 30 A / 100 W

EN/LZT 146 383 R4A September 2011

© Ericsson AB

Typical Characteristics
3.3 V, 25 A / 82.5 W

PKJ 4810E PI

Efficiency

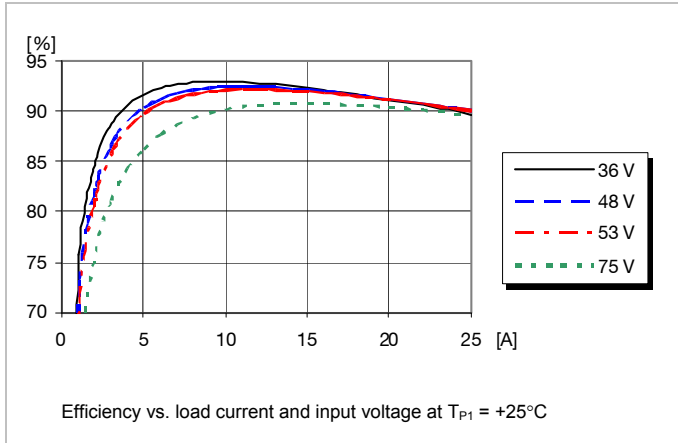

Power Dissipation

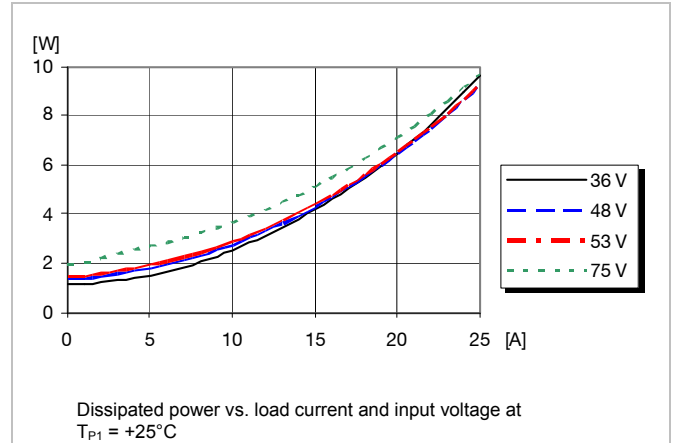

Output Characteristics

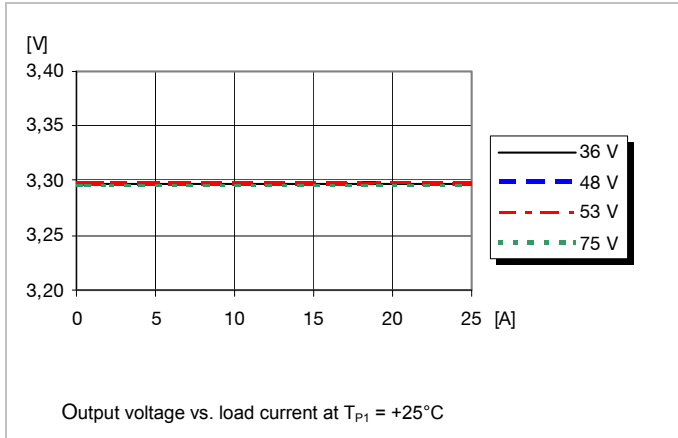

PKJ 4000E series Direct Converters
 Input 36-75 V, Output up to 30 A / 100 W

EN/LZT 146 383 R4A September 2011

© Ericsson AB

Typical Characteristics
3.3 V, 25 A / 82.5 W

PKJ 4810E PI

Start-up

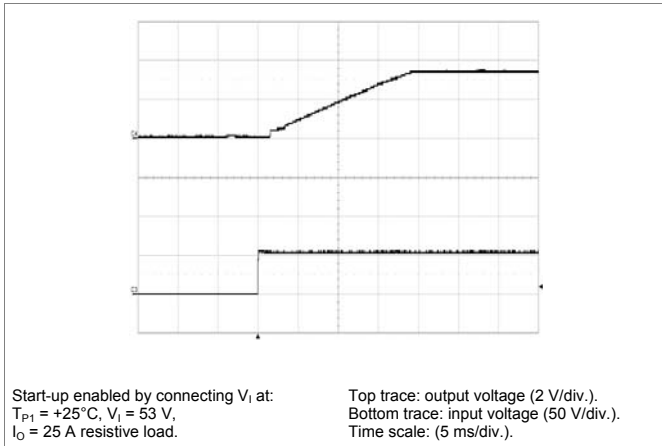

Shut-down

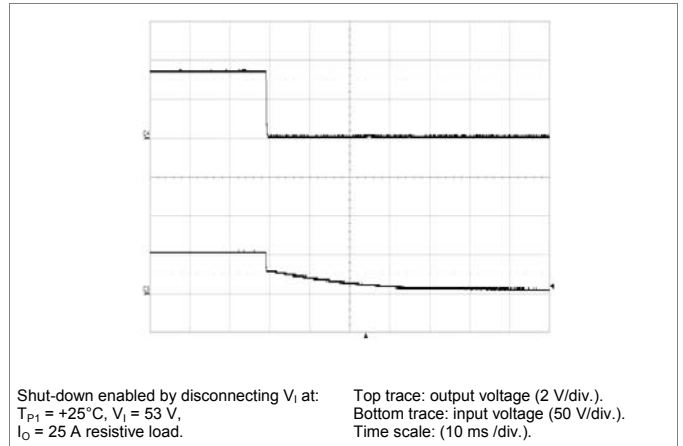

Output Ripple & Noise

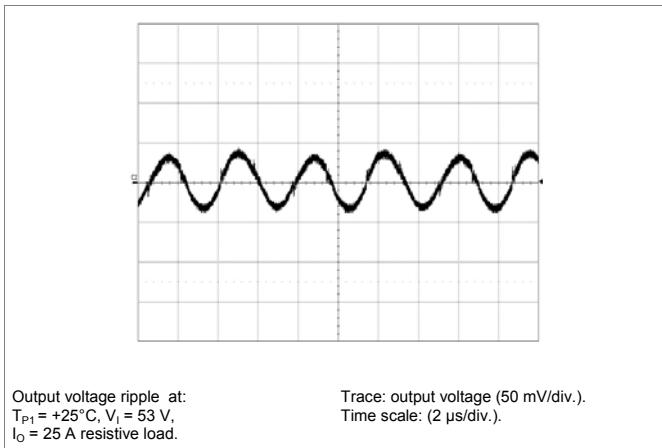

Output Load Transient Response

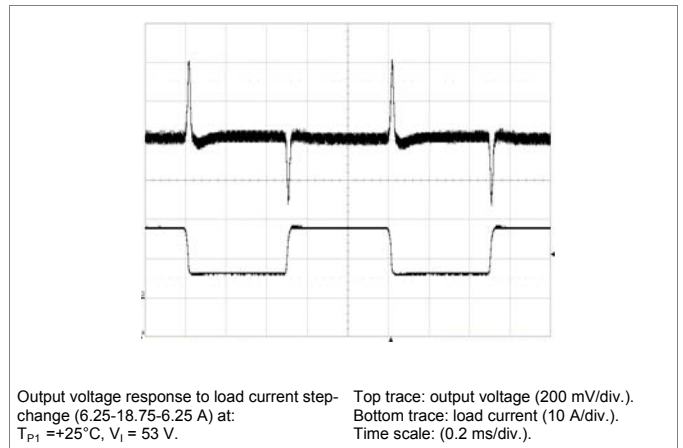

Output Voltage Adjust (see operating information)

Passive adjust

The resistor value for an adjusted output voltage is calculated by using the following equations:

Output Voltage Adjust, Decrease:

$$R_{adj} = \left[\frac{100}{\Delta\%} - 2 \right] \text{ k}\Omega$$

Example: Decrease 2% $\Rightarrow V_{out} = 2.45\text{ Vdc}$

$$\left[\frac{100}{2} - 2 \right] = 48 \text{ k}\Omega$$

Output Voltage Adjust, Increase:

$$R_{adj} = \left[\frac{3.3(100 + \Delta\%)}{1.225\Delta\%} - \frac{100 + 2\Delta\%}{\Delta\%} \right] \text{ k}\Omega$$

Example: Increase 4% $\Rightarrow V_{out} = 2.60\text{ Vdc}$

$$\left[\frac{3.3(100 + 4)}{1.225 \times 4} - \frac{100 + 2 \times 4}{4} \right] = 43 \text{ k}\Omega$$

PKJ 4000E series Direct Converters
 Input 36-75 V, Output up to 30 A / 100 W

EN/LZT 146 383 R4A September 2011

© Ericsson AB

Typical Characteristics
3.3 V, 25 A / 82.5 W

PKJ 4810E PI

Output Current Derating – Open frame

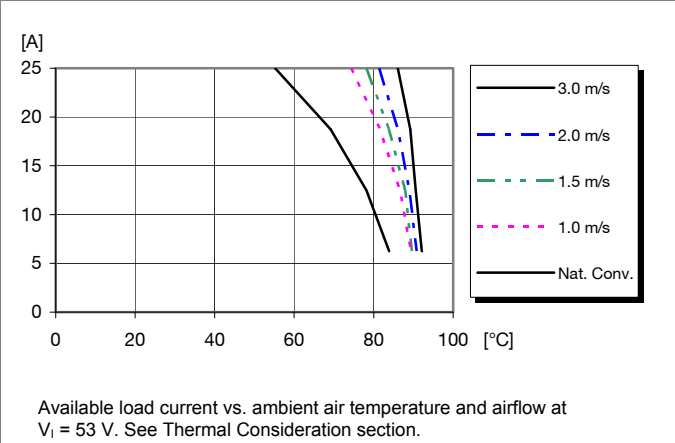

Output Current Derating – Base plate

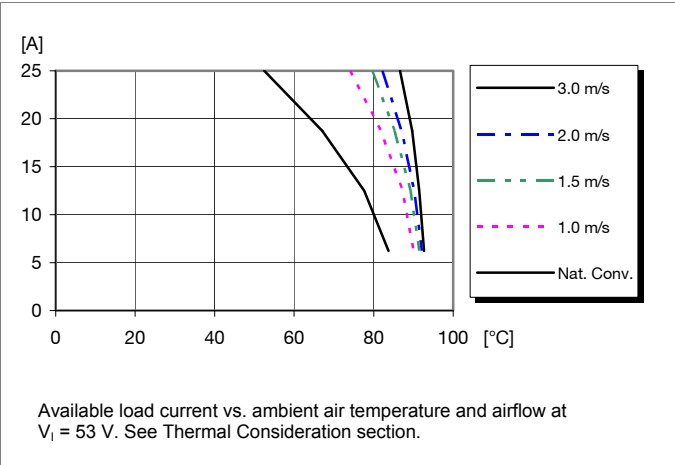

Thermal Resistance – Base plate

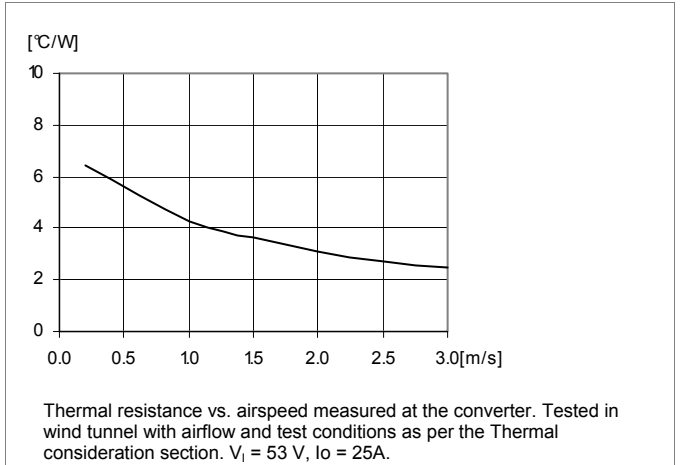

PKJ 4000E series Direct Converters
 Input 36-75 V, Output up to 30 A / 100 W

EN/LZT 146 383 R4A September 2011

© Ericsson AB

Electrical Specification
PKJ 4110E PI
3.3V, 30A / 100W
 $T_{P1} = -40$ to $+90^{\circ}\text{C}$, $V_I = 36$ to 75 V, sense pins connected to output pins unless otherwise specified under Conditions.

 Typical values given at: $T_{P1} = +25^{\circ}\text{C}$, $V_I = 53$ V, I_O max, unless otherwise specified under Conditions.

Characteristics		Conditions	min	typ	max	Unit
V_I	Input voltage range		36		75	V
V_{Ioff}	Turn-off input voltage	Decreasing input voltage	31	32	34	V
V_{Ion}	Turn-on input voltage	Increasing input voltage	33	34	36	V
C_I	Internal input capacitance			6.4		μF
P_O	Output power		0		100	W
η	Efficiency	50% of max I_O		92		%
		max I_O		88.5		
		50% of max I_O , $V_I = 48$ V		92		
		max I_O , $V_I = 48$ V		88.5		
P_d	Power Dissipation	max I_O		13	17.5	W
P_{li}	Input idling power	$I_O = 0$ A, $V_I = 53$ V		1.5		W
P_{RC}	Input standby power	$V_I = 53$ V (turned off with RC)		0.25		W
f_s	Switching frequency	100 % of max I_O	125	140	155	kHz

V_{Oi}	Output voltage initial setting and accuracy	$T_{P1} = +25^{\circ}\text{C}$, $V_I = 53$ V, $I_O = 30$ A	3.23	3.30	3.37	V
V_O	Output adjust range	See operating information	2.64		3.63	V
	Output voltage tolerance band	0-100% of max I_O	3.20		3.40	V
	Idling voltage	$I_O = 0$ A	3.23		3.37	V
	Line regulation	max I_O		0.5	5	mV
	Load regulation	$V_I = 53$ V, 0-100% of max I_O		0.5	5	mV
V_{tr}	Load transient voltage deviation	$V_I = 53$ V, Load step 25-75-25% of max I_O , $di/dt = 1$ A/ μs		± 500	± 600	mV
t_{tr}	Load transient recovery time			30	50	μs
t_r	Ramp-up time (from 10-90% of V_{Oi})	10-100% of max I_O	4.5	9	15	ms
t_s	Start-up time (from V_I connection to 90% of V_{Oi})		6	12	20	ms
t_f	V_I shut-down fall time (from V_I off to 10% of V_O)	max I_O		0.18		ms
		$I_O = 0$ A		16		s
t_{RC}	RC start-up time	max I_O		13		ms
	RC shut-down fall time (from RC off to 10% of V_O)	max I_O		0.21		ms
		$I_O = 0$ A		16		s
I_O	Output current		0		30	A
I_{lim}	Current limit threshold	$T_{P1} < \text{max } T_{P1}$	32	35	40	A
I_{sc}	Short circuit current	$T_{P1} = 25^{\circ}\text{C}$, see Note 1		45	50	A
C_{out}	Recommended Capacitive Load	$T_{P1} = 25^{\circ}\text{C}$, see Note 2	0		10000	μF
V_{Oac}	Output ripple & noise	See ripple & noise section, V_{Oi}		120	180	mVp-p
OVP	Over voltage protection	$T_{P1} = +25^{\circ}\text{C}$, $V_I = 53$ V, 0-100% of max I_O	3.9	5	6.0	V

Note 1: See Operating Information section

Note 2: Cout: OSCON type and ESR<5 mohm

PKJ 4000E series Direct Converters
 Input 36-75 V, Output up to 30 A / 100 W

EN/LZT 146 383 R4A September 2011

© Ericsson AB

Typical Characteristics
3.3V, 30A / 100W

PKJ 4110E PI

Efficiency

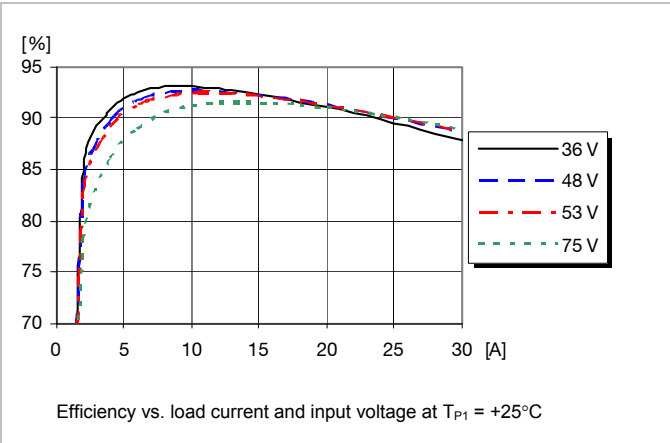

Power Dissipation

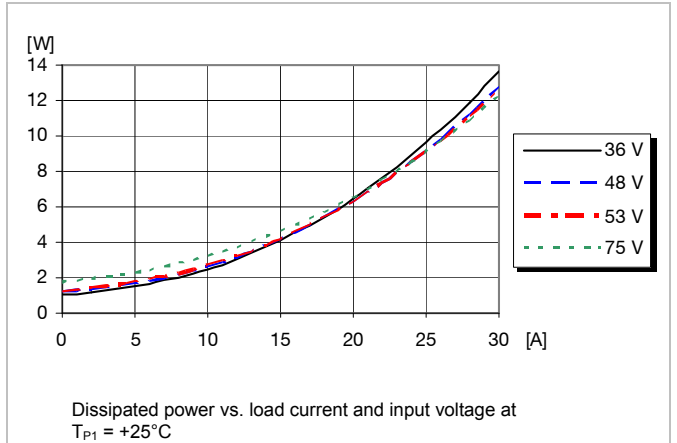

Output Characteristics

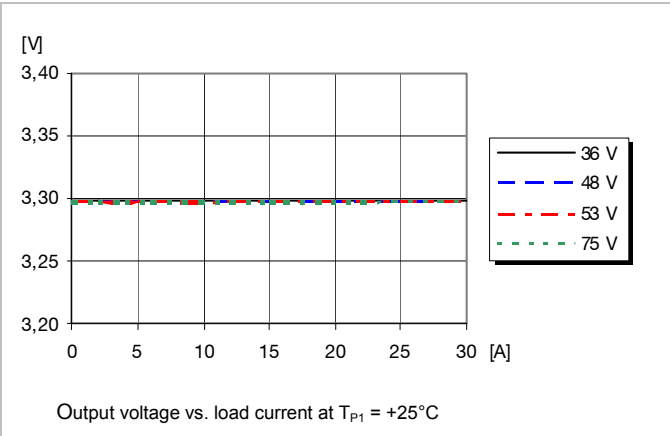

PKJ 4000E series Direct Converters
 Input 36-75 V, Output up to 30 A / 100 W

EN/LZT 146 383 R4A September 2011

© Ericsson AB

Typical Characteristics
3.3V, 30A / 100W

PKJ 4110E PI

Start-up

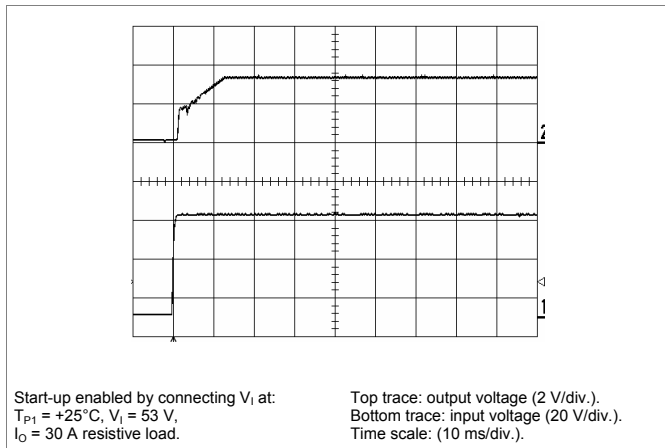

Shut-down

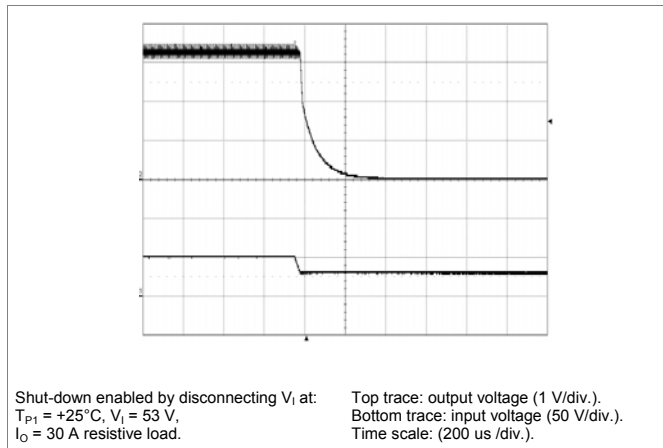

Output Ripple & Noise

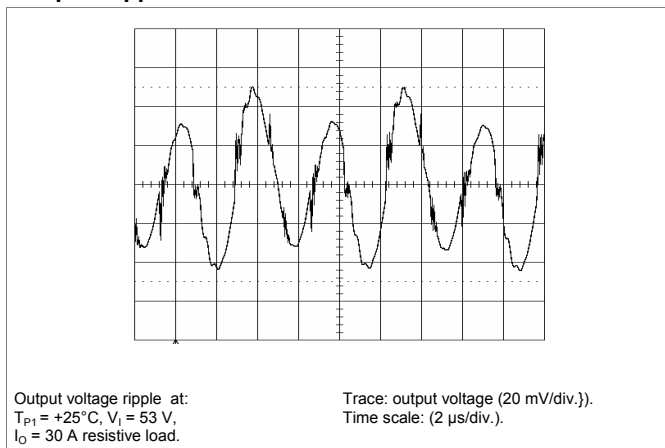

Output Load Transient Response

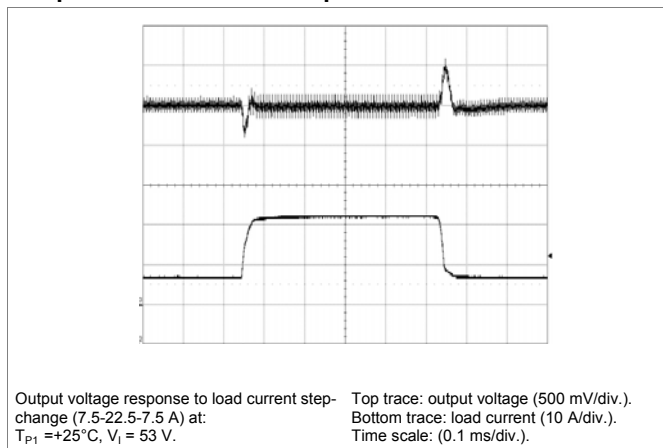

Output Voltage Adjust (see operating information)

Passive adjust

The resistor value for an adjusted output voltage is calculated by using the following equations:

Output Voltage Adjust, Decrease:

$$R_{adj} = \left[\frac{100}{\Delta\%} - 2 \right] \text{ k}\Omega$$

Example: Decrease 2% $\Rightarrow V_{out} = 2.45\text{ Vdc}$

$$\left[\frac{100}{2} - 2 \right] = 48\text{ k}\Omega$$

Output Voltage Adjust, Increase:

$$R_{adj} = \left[\frac{3.3(100 + \Delta\%)}{1.225\Delta\%} - \frac{100 + 2\Delta\%}{\Delta\%} \right] \text{ k}\Omega$$

Example: Increase 4% $\Rightarrow V_{out} = 2.60\text{ Vdc}$

$$\left[\frac{3.3(100 + 4)}{1.225 \times 4} - \frac{100 + 2 \times 4}{4} \right] = 43\text{ k}\Omega$$

PKJ 4000E series Direct Converters
 Input 36-75 V, Output up to 30 A / 100 W

EN/LZT 146 383 R4A September 2011

© Ericsson AB

Typical Characteristics
3.3V, 30A / 100W

PKJ 4110E PI

Output Current Derating – Open frame

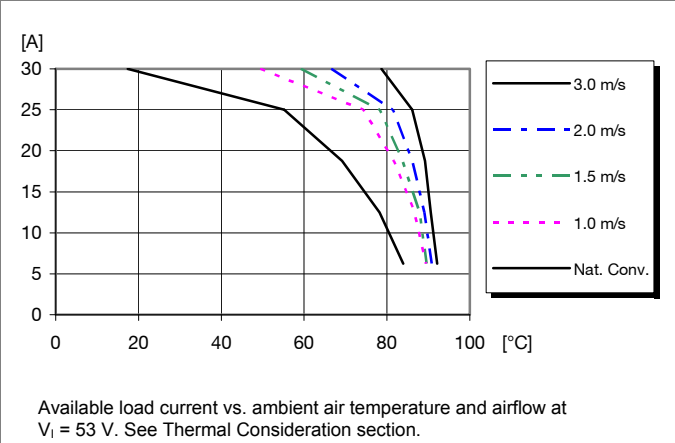

Output Current Derating – Base plate

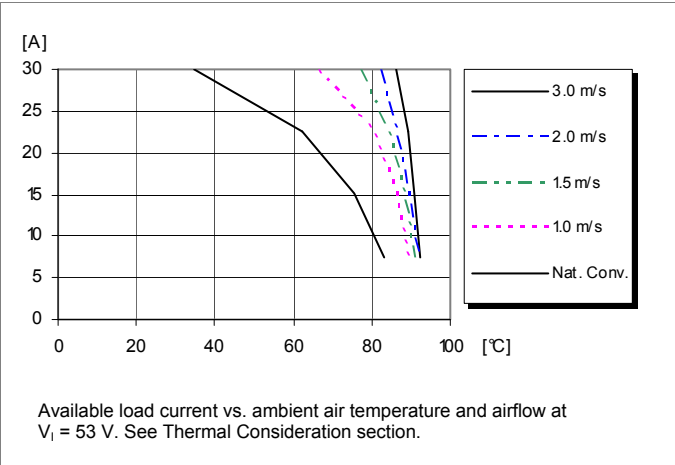

Thermal Resistance – Base plate

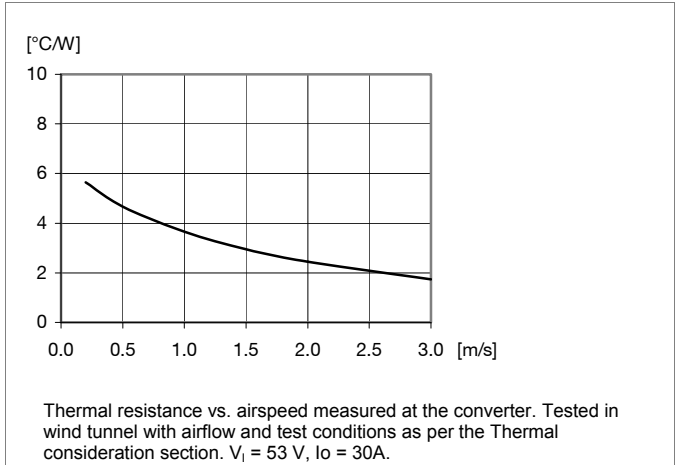

PKJ 4000E series Direct Converters
 Input 36-75 V, Output up to 30 A / 100 W

EN/LZT 146 383 R4A September 2011

© Ericsson AB

Electrical Specification
5V, 20A / 100W
PKJ 4111E PI

$T_{P1} = -40$ to $+90^{\circ}\text{C}$, $V_I = 36$ to 75 V, sense pins connected to output pins unless otherwise specified under Conditions.
 Typical values given at: $T_{P1} = +25^{\circ}\text{C}$, $V_I = 53$ V, I_O max, unless otherwise specified under Conditions.

Characteristics		Conditions	min	typ	max	Unit
V_I	Input voltage range		36		75	V
V_{Ioff}	Turn-off input voltage	Decreasing input voltage	31	32	34	V
V_{Ion}	Turn-on input voltage	Increasing input voltage	33	34	36	V
C_I	Internal input capacitance			6.4		μF
P_O	Output power		0		100	W
η	Efficiency	50% of max I_O		92		%
		max I_O		90		
		50% of max I_O , $V_I = 48$ V		92		
		max I_O , $V_I = 48$ V		90		
P_d	Power Dissipation	max I_O		11	16	W
P_{li}	Input idling power	$I_O = 0$ A, $V_I = 53$ V		1.7		W
P_{RC}	Input standby power	$V_I = 53$ V (turned off with RC)		0.25		W
f_s	Switching frequency	100 % of max I_O	125	140	155	kHz

V_{Oi}	Output voltage initial setting and accuracy	$T_{P1} = +25^{\circ}\text{C}$, $V_I = 53$ V, $I_O = 30$ A	4.89	5.0	5.11	V
V_O	Output adjust range	See operating information	4.0		5.5	V
	Output voltage tolerance band	0-100% of max I_O	4.85		5.15	V
	Idling voltage	$I_O = 0$ A	4.89		5.11	V
	Line regulation	max I_O		3	7	mV
	Load regulation	$V_I = 53$ V, 0-100% of max I_O		5	12	mV
V_{tr}	Load transient voltage deviation	$V_I = 53$ V, Load step 25-75-25% of max I_O , $di/dt = 1$ A/ μs		± 400	± 500	mV
t_{tr}	Load transient recovery time			30	60	μs
t_r	Ramp-up time (from 10-90% of V_{Oi})	10-100% of max I_O	8	15	30	ms
t_s	Start-up time (from V_I connection to 90% of V_{Oi})		10	20	40	ms
t_f	V_I shut-down fall time (from V_I off to 10% of V_O)	max I_O		0.35		ms
		$I_O = 0$ A		9		s
t_{RC}	RC start-up time	max I_O		17		ms
	RC shut-down fall time (from RC off to 10% of V_O)	max I_O		0.38		ms
		$I_O = 0$ A		9		s
I_O	Output current		0		20	A
I_{lim}	Current limit threshold	$T_{P1} < \text{max } T_{P1}$	20.3	23	25	A
I_{sc}	Short circuit current	$T_{P1} = 25^{\circ}\text{C}$, see Note 1		26	30	A
C_{out}	Recommended Capacitive Load	$T_{P1} = 25^{\circ}\text{C}$, see Note 2	0		10000	μF
V_{Oac}	Output ripple & noise	See ripple & noise section, V_{Oi}		110	150	mVp-p
OVP	Over voltage protection	$T_{P1} = +25^{\circ}\text{C}$, $V_I = 53$ V, 0-100% of max I_O	6.0	6.7	7.5	V

Note 1: See Operating Information section

Note 2: Cout: OSCON type and ESR<5 mohm

PKJ 4000E series Direct Converters
 Input 36-75 V, Output up to 30 A / 100 W

EN/LZT 146 383 R4A September 2011

© Ericsson AB

Typical Characteristics
5V, 20A / 100W

PKJ 4111E PI

Efficiency

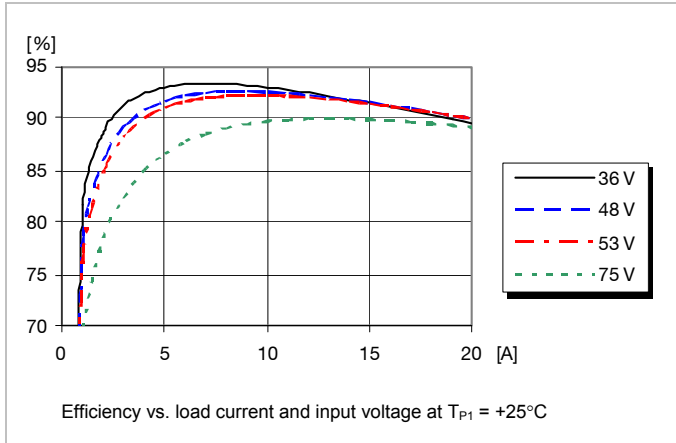

Power Dissipation

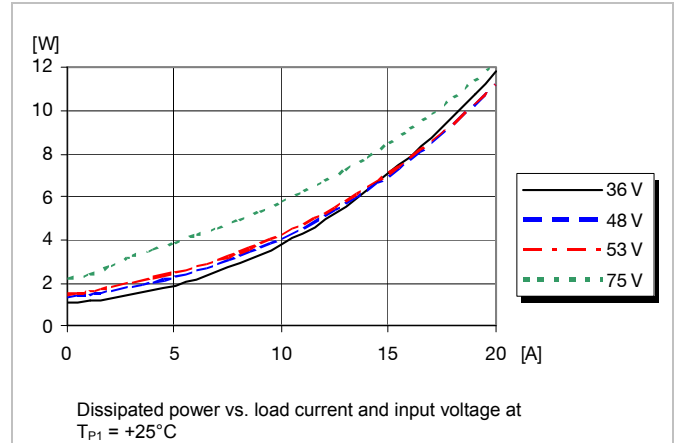

Output Characteristics

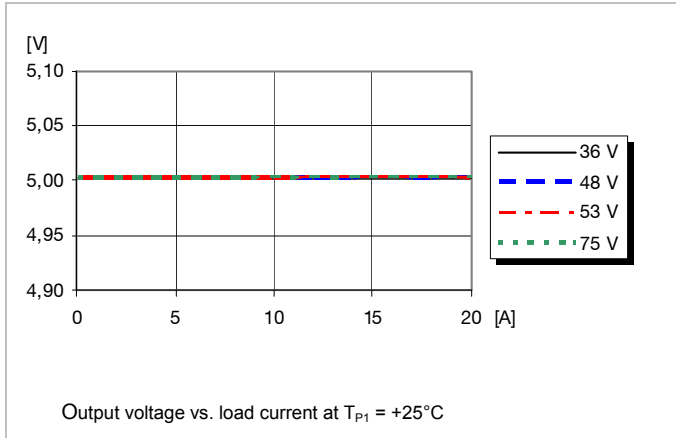

PKJ 4000E series Direct Converters
 Input 36-75 V, Output up to 30 A / 100 W

EN/LZT 146 383 R4A September 2011

© Ericsson AB

Typical Characteristics
5V, 20A / 100W

PKJ 4111E PI

Start-up

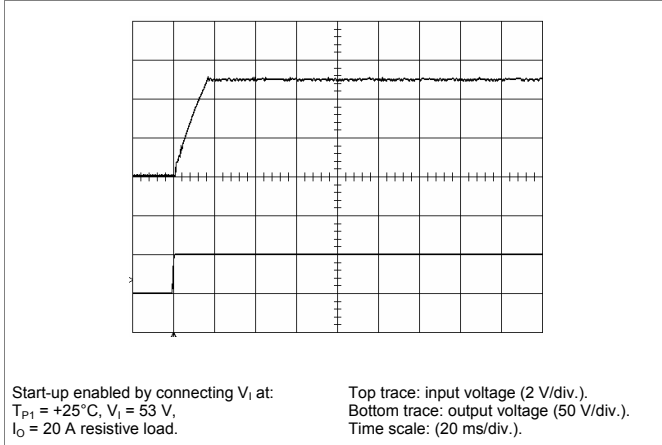

Shut-down

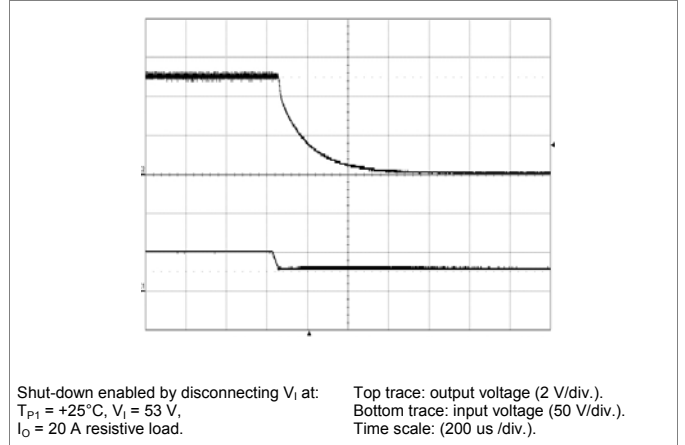

Output Ripple & Noise

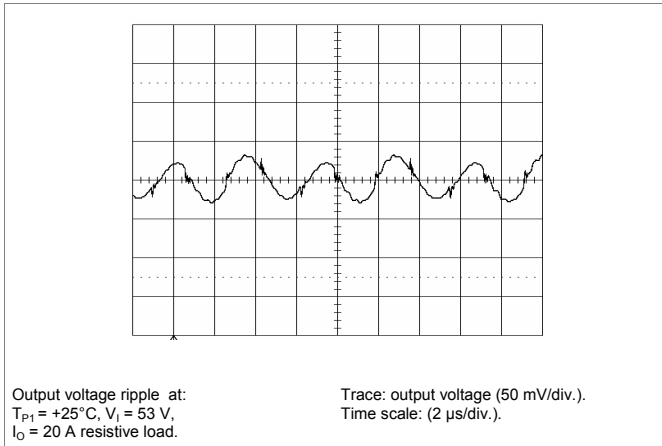

Output Load Transient Response

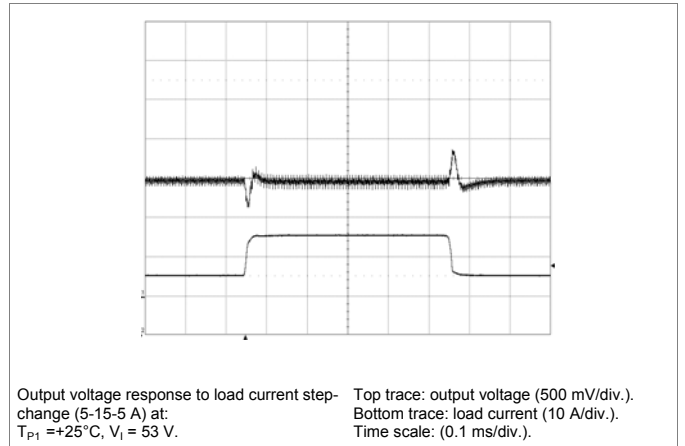

Output Voltage Adjust (see operating information)

Passive adjust

The resistor value for an adjusted output voltage is calculated by using the following equations:

Output Voltage Adjust, Decrease:

$$R_{adj} = \left[\frac{100}{\Delta\%} - 2 \right] \text{ k}\Omega$$

Example: Decrease 2% $\Rightarrow V_{out} = 4.9\text{ Vdc}$

$$\left[\frac{100}{2} - 2 \right] = 48\text{ k}\Omega$$

Output Voltage Adjust, Increase:

$$R_{adj} = \left[\frac{5.0(100 + \Delta\%)}{1.225\Delta\%} - \frac{100 + 2\Delta\%}{\Delta\%} \right] \text{ k}\Omega$$

Example: Increase 4% $\Rightarrow V_{out} = 5.2\text{ Vdc}$

$$\left[\frac{5.0(100 + 4)}{1.225 \times 4} - \frac{100 + 2 \times 4}{4} \right] = 79.1\text{ k}\Omega$$

PKJ 4000E series Direct Converters
 Input 36-75 V, Output up to 30 A / 100 W

EN/LZT 146 383 R4A September 2011

© Ericsson AB

Typical Characteristics
5 V, 20 A / 100 W

PKJ 4111E PI

Output Current Derating – Open frame

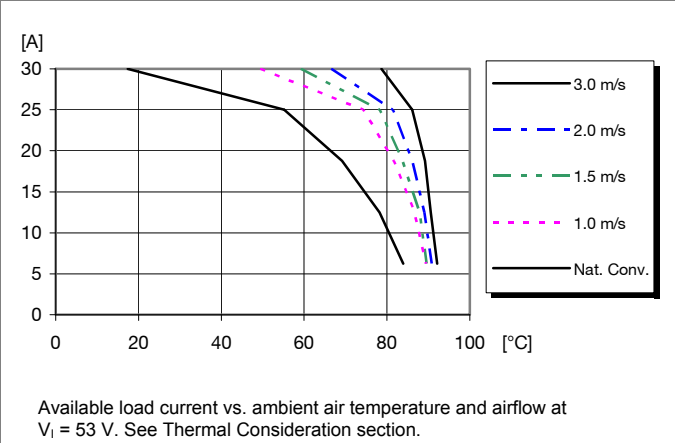

Output Current Derating – Base plate

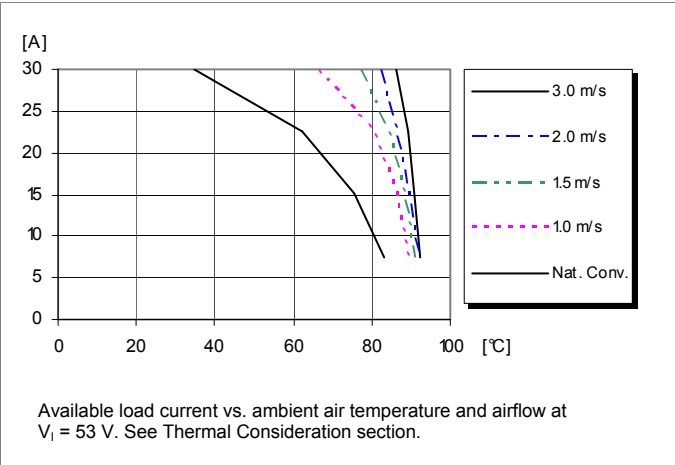

Thermal Resistance – Base plate

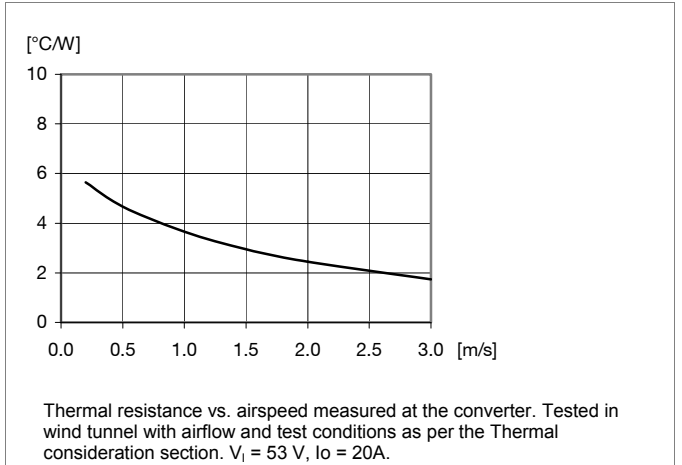

PKJ 4000E series Direct Converters
 Input 36-75 V, Output up to 30 A / 100 W

EN/LZT 146 383 R4A September 2011

© Ericsson AB

Electrical Specification
12V, 8.3A / 100W
PKJ 4113E PI
 $T_{P1} = -40$ to $+90^{\circ}\text{C}$, $V_I = 36$ to 75 V, sense pins connected to output pins unless otherwise specified under Conditions.

 Typical values given at: $T_{P1} = +25^{\circ}\text{C}$, $V_I = 53$ V, I_O max, unless otherwise specified under Conditions.

Characteristics		Conditions	min	typ	max	Unit
V_I	Input voltage range		36		75	V
V_{Ioff}	Turn-off input voltage	Decreasing input voltage	31	32	34	V
V_{Ion}	Turn-on input voltage	Increasing input voltage	33	34	36	V
C_I	Internal input capacitance			6.4		μF
P_O	Output power		0		100	W
η	Efficiency	50% of max I_O		91.5		%
		max I_O		89.5		
		50% of max I_O , $V_I = 48$ V		92.5		
		max I_O , $V_I = 48$ V		90		
P_d	Power Dissipation	max I_O		11.2	16	W
P_{li}	Input idling power	$I_O = 0$ A, $V_I = 53$ V		1.4		W
P_{RC}	Input standby power	$V_I = 53$ V (turned off with RC)		0.25		W
f_s	Switching frequency	100 % of max I_O	195	220	245	kHz

V_{Oi}	Output voltage initial setting and accuracy	$T_{P1} = +25^{\circ}\text{C}$, $V_I = 53$ V, $I_O = 30$ A	11.8	12.0	12.2	V
V_O	Output adjust range	See operating information	9.6		13.2	V
	Output voltage tolerance band	0-100% of max I_O	11.7		12.3	V
	Idling voltage	$I_O = 0$ A	11.8		12.2	V
	Line regulation	max I_O		3	10	mV
	Load regulation	$V_I = 53$ V, 0-100% of max I_O		3	10	mV
V_{tr}	Load transient voltage deviation	$V_I = 53$ V, Load step 25-75-25% of max I_O , $di/dt = 1$ A/ μs		± 700	± 780	mV
t_{tr}	Load transient recovery time			50	80	μs
t_r	Ramp-up time (from 10-90% of V_{Oi})	10-100% of max I_O	5	8.5	15	ms
t_s	Start-up time (from V_I connection to 90% of V_{Oi})		7	10.5	20	ms
t_f	V_I shut-down fall time (from V_I off to 10% of V_O)	max I_O		0.22		ms
		$I_O = 0$ A		0.834		s
t_{RC}	RC start-up time	max I_O		10.5		ms
	RC shut-down fall time (from RC off to 10% of V_O)	max I_O		0.24		ms
$I_O = 0$ A				0.714		s
I_O	Output current		0		8.33	A
I_{lim}	Current limit threshold	$T_{P1} < \text{max } T_{P1}$	10	11	13	A
I_{sc}	Short circuit current	$T_{P1} = 25^{\circ}\text{C}$, see Note 1		15	20	A
C_{out}	Recommended Capacitive Load	$T_{P1} = 25^{\circ}\text{C}$, see Note 2	0		3000	μF
V_{Oac}	Output ripple & noise	See ripple & noise section, V_{Oi}		110	150	mVp-p
OVP	Over voltage protection	$T_{P1} = +25^{\circ}\text{C}$, $V_I = 53$ V, 0-100% of max I_O	15	17	19	V

Note 1: See Operating Information section

Note 2: Cout: OSCON type and ESR<5 mohm

PKJ 4000E series Direct Converters
 Input 36-75 V, Output up to 30 A / 100 W

EN/LZT 146 383 R4A September 2011

© Ericsson AB

Typical Characteristics
12V, 8.3A / 100W

PKJ 4113E PI

Efficiency

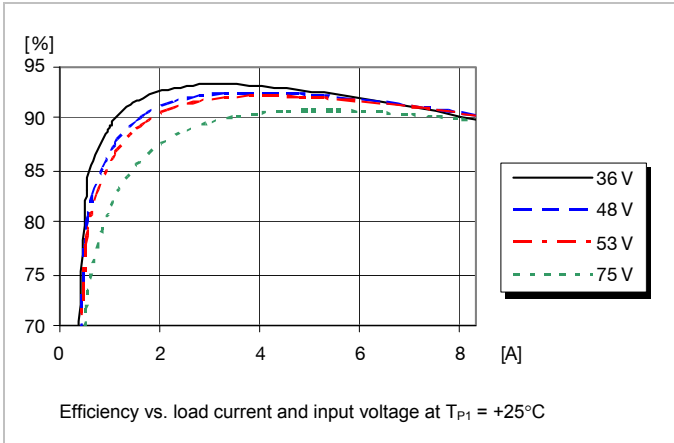

Power Dissipation

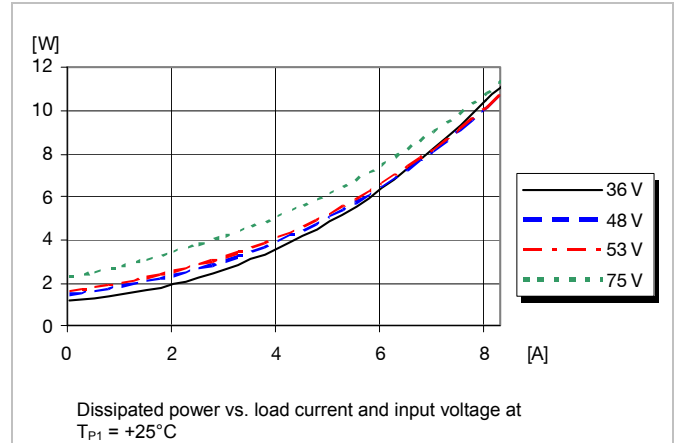

Output Characteristics

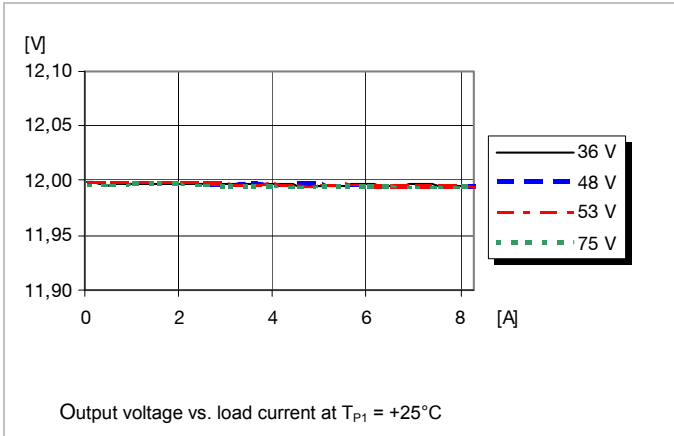

PKJ 4000E series Direct Converters
 Input 36-75 V, Output up to 30 A / 100 W

EN/LZT 146 383 R4A September 2011

© Ericsson AB

Typical Characteristics
12V, 8.3A / 100W

PKJ 4113E PI

Start-up

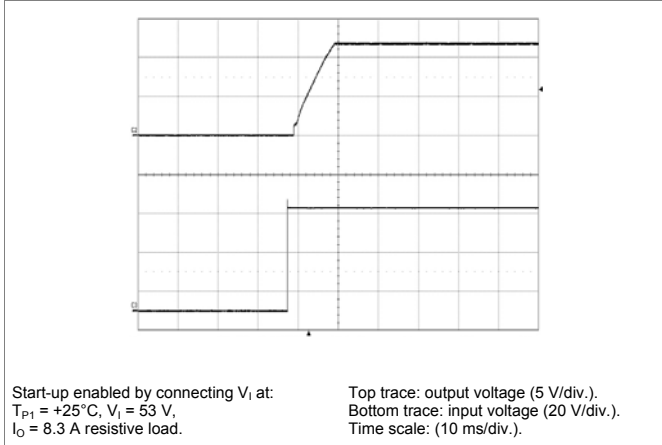

Shut-down

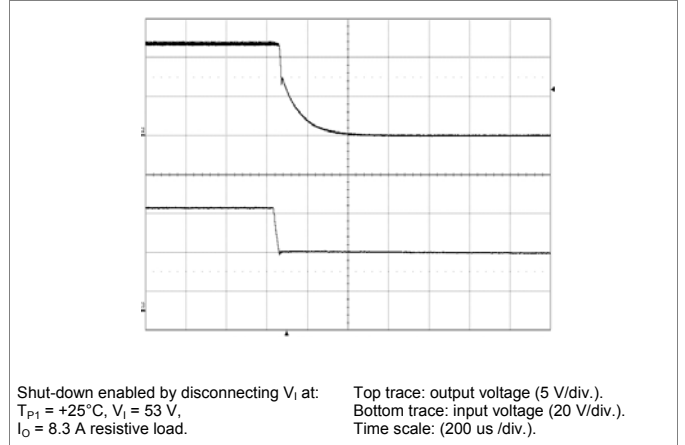

Output Ripple & Noise

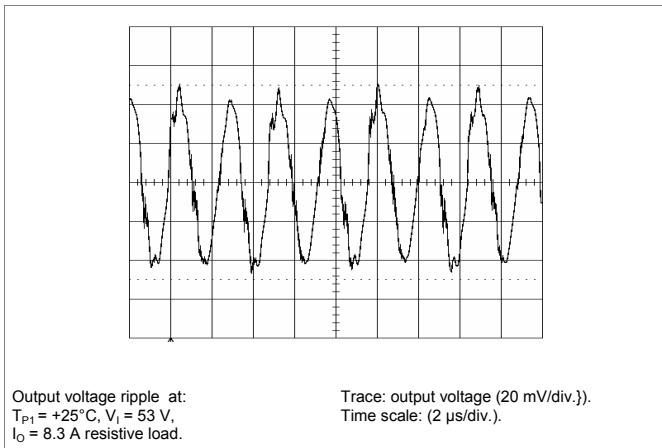

Output Load Transient Response

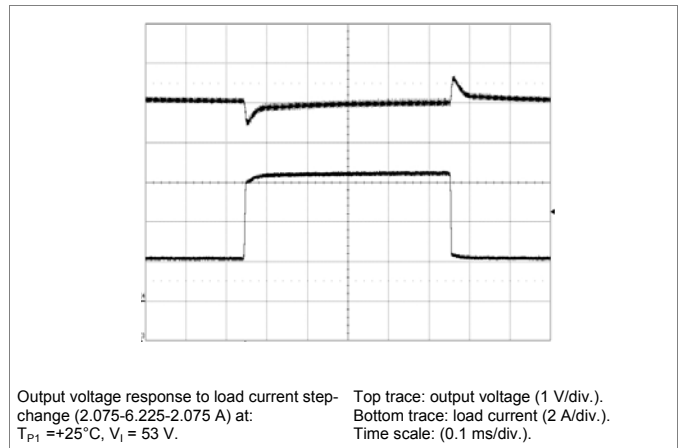

Output Voltage Adjust (see operating information)

Passive adjust

The resistor value for an adjusted output voltage is calculated by using the following equations:

Output Voltage Adjust, Decrease:

$$R_{adj} = \left[\frac{100}{\Delta\%} - 2 \right] \text{ k}\Omega$$

Example: Decrease 2% $\Rightarrow V_{out} = 11.76\text{ Vdc}$

$$\left[\frac{100}{2} - 2 \right] = 48\text{ k}\Omega$$

Output Voltage Adjust, Increase:

$$R_{adj} = \left[\frac{12(100 + \Delta\%)}{1.225\Delta\%} - \frac{100 + 2\Delta\%}{\Delta\%} \right] \text{ k}\Omega$$

Example: Increase 4% $\Rightarrow V_{out} = 12.48\text{ Vdc}$

$$\left[\frac{12(100 + 4)}{1.225 \times 4} - \frac{100 + 2 \times 4}{4} \right] = 227.7\text{ k}\Omega$$

PKJ 4000E series Direct Converters
 Input 36-75 V, Output up to 30 A / 100 W

EN/LZT 146 383 R4A September 2011

© Ericsson AB

Typical Characteristics
12 V, 8.3 A / 100 W

PKJ 4113E PI

Output Current Derating – Open frame

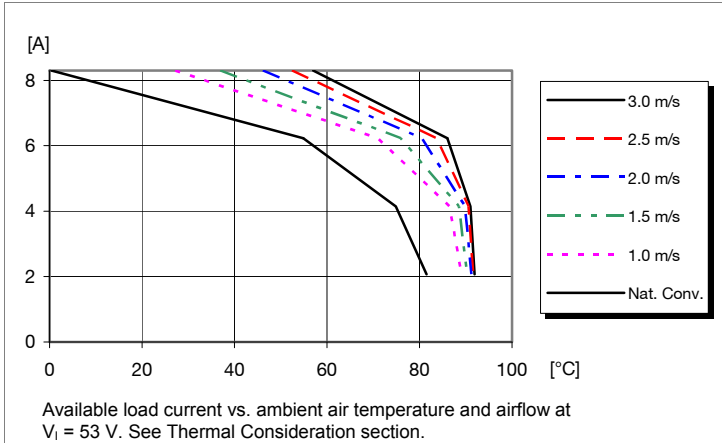

Output Current Derating – Base plate

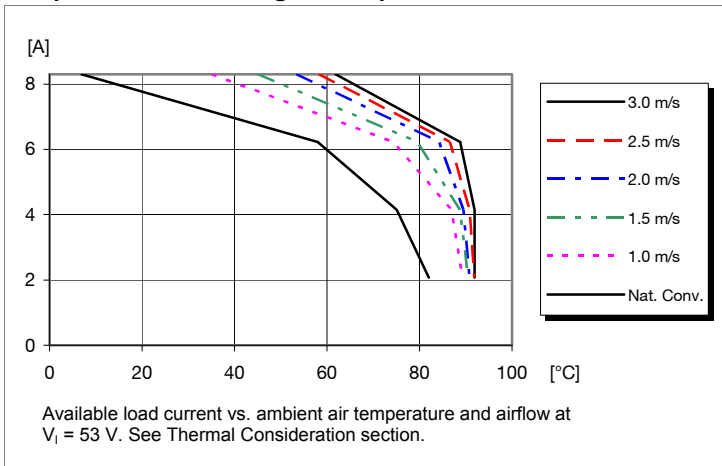

Thermal Resistance – Base plate

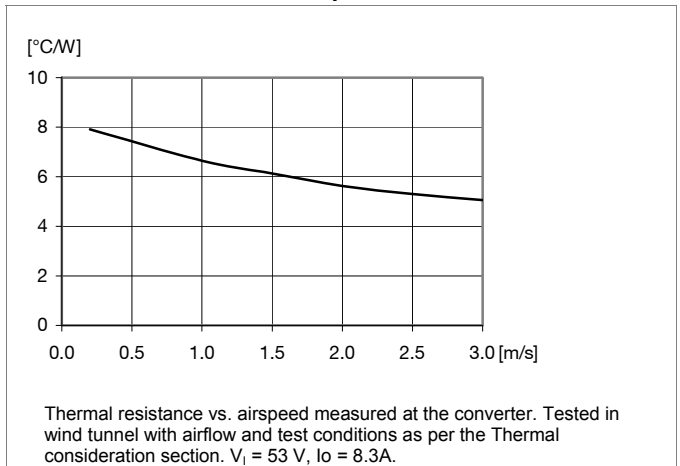

PKJ 4000E series Direct Converters
Input 36-75 V, Output up to 30 A / 100 W

EN/LZT 146 383 R4A September 2011

© Ericsson AB

EMC Specification

Conducted EMI measured according to EN55022, CISPR 22 and FCC part 15J (see test set-up). See Design Note 009 for further information. The fundamental switching frequency is 140 kHz for PKJ 4810E PI @ $V_I = 53$ V, max I_O .

Conducted EMI Input terminal value (typ)

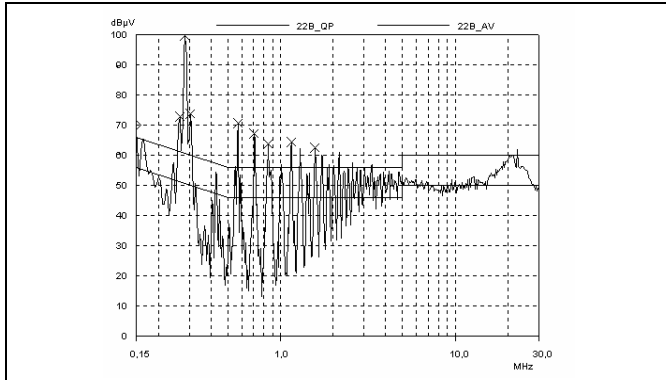

EMI without filter

External filter (class B)

Required external input filter in order to meet class B in EN 55022, CISPR 22 and FCC part 15J.

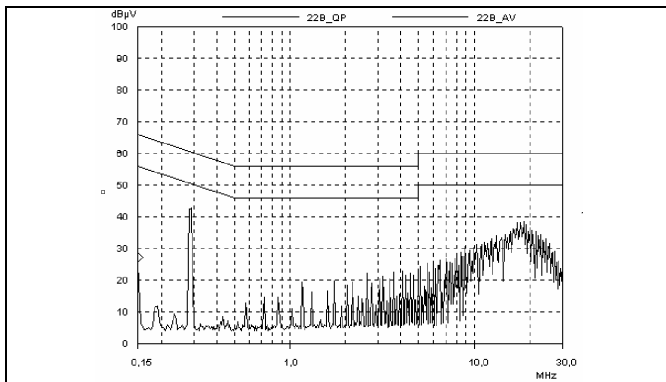
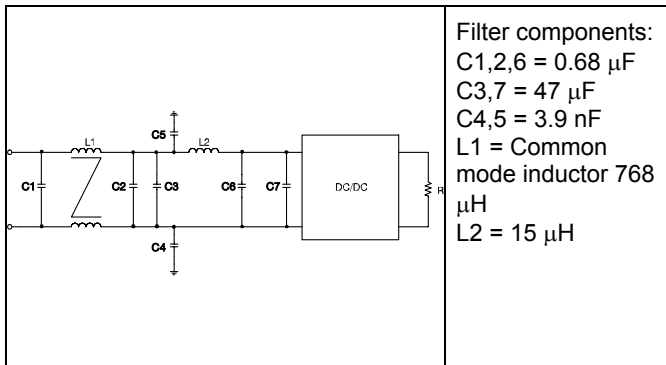

EMI with filter

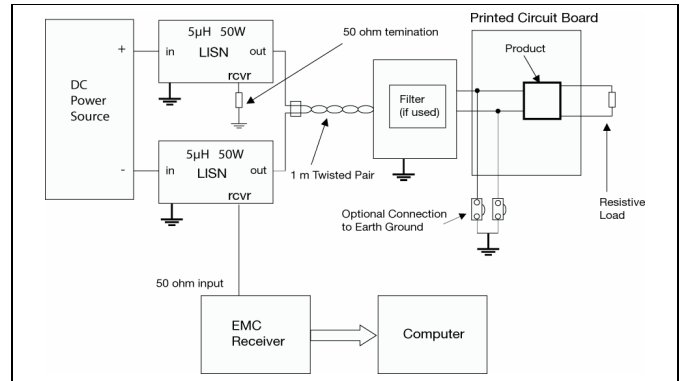

Test set-up

Layout recommendations

The radiated EMI performance of the Product will depend on the PCB layout and ground layer design. It is also important to consider the stand-off of the product. If a ground layer is used, it should be connected to the output of the product and the equipment ground or chassis.

A ground layer will increase the stray capacitance in the PCB and improve the high frequency EMC performance.

Output ripple and noise

Output ripple and noise measured according to figure below. See Design Note 022 for detailed information.

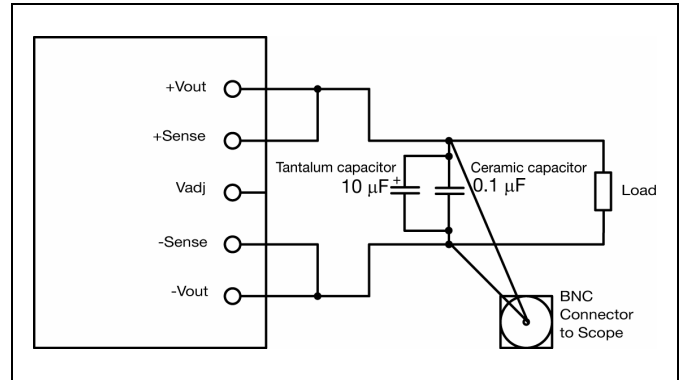

Output ripple and noise test setup

PKJ 4000E series Direct Converters
 Input 36-75 V, Output up to 30 A / 100 W

EN/LZT 146 383 R4A September 2011

© Ericsson AB

Operating information

Input Voltage

The input voltage range 36 to 75 Vdc meets the requirements of the European Telecom Standard ETS 300 132-2 for normal input voltage range in -48 and -60 Vdc systems, -40.5 to -57.0 V and -50.0 to -72 V respectively. At input voltages exceeding 75 V, the power loss will be higher than at normal input voltage and T_{P1} must be limited to absolute max +125°C. The absolute maximum continuous input voltage is 80 Vdc.

Turn-off Input Voltage

The products monitor the input voltage and will turn on and turn off at predetermined levels. The minimum hysteresis between turn on and turn off input voltage is 1 V.

Remote Control (RC)

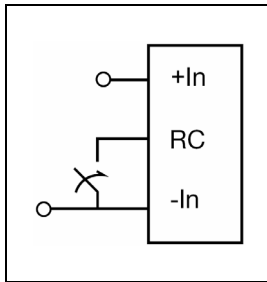

The products are fitted with a remote control function referenced to the primary negative input connection (-In), with negative and positive logic options available. The RC function allows the product to be turned on/off by an external device like a semiconductor or mechanical switch. The RC pin has an internal pull up resistor to +In.

The maximum required sink current is 1 mA. When the RC pin is left open, the voltage generated on the RC pin is 3.5 – 6.0 V. The standard product is provided with “negative logic” remote control and will be off until the RC pin is connected to the -In. To turn on the product the voltage between RC pin and -In should be less than 1V. To turn off the converter the RC pin should be left open, or connected to a voltage higher than 4 V referenced to -In. In situations where it is desired to have the product to power up automatically without the need for control signals or a switch, the RC pin can be wired directly to -In.

The second option is “positive logic” remote control, which can be ordered by adding the suffix “P” to the end of the part number. When the RC pin is left open, the product starts up automatically when the input voltage is applied. Turn off is achieved by connecting the RC pin to the -In. To ensure safe turn off the voltage difference between RC pin and the -In pin shall be less than 1V. The product will restart automatically when this connection is opened.

See Design Note 021 for detailed information.

Input and Output Impedance

The impedance of both the input source and the load will interact with the impedance of the product. It is important that the input source has low characteristic impedance. The products are designed for stable operation without external capacitors connected to the input or output. The performance

in some applications can be enhanced by addition of external capacitance as described under External Decoupling Capacitors.

If the input voltage source contains significant inductance, the addition of a 22 - 100 μ F capacitor across the input of the product will ensure stable operation. The capacitor is not required when powering the product from an input source with an inductance below 10 μ H. The minimum required capacitance value depends on the output power and the input voltage. The higher output power the higher input capacitance is needed. Approximately doubled capacitance value is required for a 24 V input voltage source compared to a 48V input voltage source.

External Decoupling Capacitors

When powering loads with significant dynamic current requirements, the voltage regulation at the point of load can be improved by addition of decoupling capacitors at the load. The most effective technique is to locate low ESR ceramic and electrolytic capacitors as close to the load as possible, using several parallel capacitors to lower the effective ESR. The ceramic capacitors will handle high-frequency dynamic load changes while the electrolytic capacitors are used to handle low frequency dynamic load changes. It is equally important to use low resistance and low inductance PCB layouts and cabling.

External decoupling capacitors will become part of the control loop of the DC/DC converter and may affect the stability margins. As a “rule of thumb”, 100 μ F/A of output current can be added without any additional analysis. The ESR of the capacitors is a very important parameter. Power Modules guarantee stable operation with a verified ESR value of >10 m Ω across the output connections.

For further information please contact your local Ericsson Power Modules representative.

Output Voltage Adjust (V_{adj})

The products have an Output Voltage Adjust pin (V_{adj}). This pin can be used to adjust the output voltage above or below Output voltage initial setting.

When increasing the output voltage, the voltage at the output pins (including any remote sense compensation) must be kept below the threshold of the over voltage protection, (OVP) to prevent the product from shutting down. At increased output voltages the maximum power rating of the product remains the same, and the max output current must be decreased correspondingly.

To increase the voltage the resistor should be connected between the V_{adj} pin and +Sense pin. The resistor value of the Output voltage adjust function is according to information given under the Output section for the respective product.

To decrease the output voltage, the resistor should be connected between the V_{adj} pin and -Sense pin.

PKJ 4000E series Direct Converters
 Input 36-75 V, Output up to 30 A / 100 W

EN/LZT 146 383 R4A September 2011

© Ericsson AB

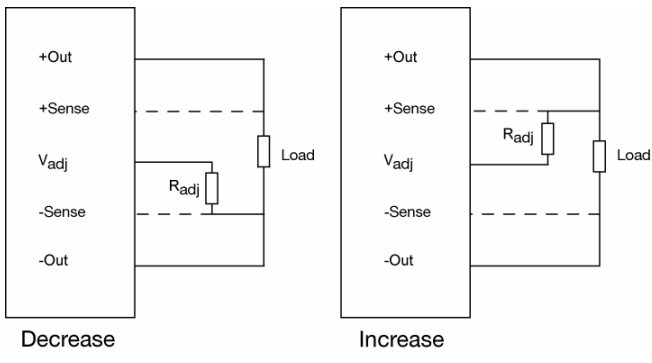

Thermal Consideration

General

The products are designed to operate in different thermal environments and sufficient cooling must be provided to ensure reliable operation.

For products mounted on a PCB without a heat sink attached, cooling is achieved mainly by conduction, from the pins to the host board, and convection, which is dependant on the airflow across the product. Increased airflow enhances the cooling of the product. The Output Current Derating graph found in the Output section for each model provides the available output current vs. ambient air temperature and air velocity at $V_1 = 53 \text{ V}$.

The product is tested on a 254 x 254 mm, 35 μm (1 oz), 16-layer test board mounted vertically in a wind tunnel with a cross-section of 608 x 203 mm.

Operating information continued

Parallel Operation

Two products may be paralleled for redundancy if the total power is equal or less than $P_O \text{ max}$. It is not recommended to parallel the products without using external current sharing circuits.

See Design Note 006 for detailed information.

Remote Sense

The products have remote sense that can be used to compensate for voltage drops between the output and the point of load. The sense traces should be located close to the PCB ground layer to reduce noise susceptibility. The remote sense circuitry will compensate for up to 10% voltage drop between output pins and the point of load.

If the remote sense is not needed +Sense should be connected to +Out and -Sense should be connected to -Out.

Over Temperature Protection (OTP)

The products are protected from thermal overload by an internal over temperature shutdown circuit. When T_{P1} as defined in thermal consideration section exceeds 135°C the product will shut down immediately (latching). The product can be restarted by cycling the input voltage or using the remote control function.

Over Voltage Protection (OVP)

The products have latching output over voltage protection that immediately will shut down the product in over voltage conditions. The product can be restarted by cycling the input voltage or using the remote control function.

Over Current Protection (OCP)

The products include current limiting circuitry for protection at continuous overload. The output voltage will decrease towards zero for output currents in excess of max output current ($\text{max } I_O$). The product will resume normal operation after removal of the overload. The load distribution should be designed for the maximum output short circuit current specified.

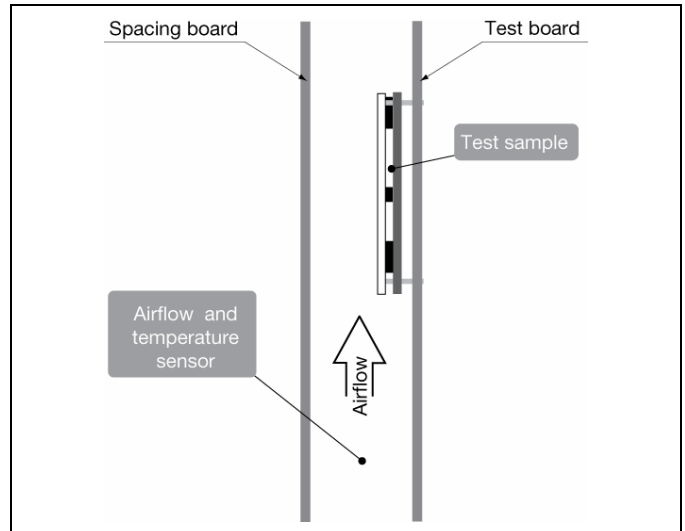

PKJ 4000E series Direct Converters
 Input 36-75 V, Output up to 30 A / 100 W

EN/LZT 146 383 R4A September 2011

© Ericsson AB

Proper cooling of the product can be verified by measuring the temperature at positions P1, P2 and P3. The temperature at these positions should not exceed the max values provided in the table below. The number of points may vary with different thermal design and topology.

See Design Note 019 for further information.

Position	Description	Temp. limit
P1	Reference point, PCB	125° C
P2	Core transformer	125° C
P3	Reference point, Baseplate	125° C

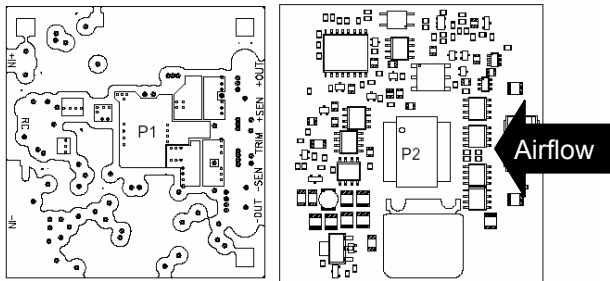

Open frame

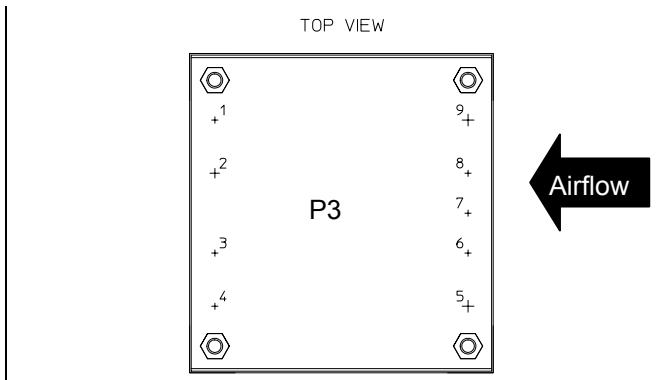

Base plate

Ambient Temperature Calculation

For products with base plate the maximum allowed ambient temperature can be calculated by using the thermal resistance.

1. The power loss is calculated by using the formula $((1/\eta) - 1) \times \text{output power} = \text{power losses (Pd)}$.
 η = efficiency of product. E.g. 89.5% = 0.895

2. Find the thermal resistance (Rth) in the Thermal Resistance graph found in the Output section for each model. **Note that the thermal resistance can be significantly reduced if a heat sink is mounted on the top of the base plate.**

Calculate the temperature increase (ΔT).

$$\Delta T = R_{th} \times P_d$$

3. Max allowed ambient temperature is:

$$\text{Max } T_{P1} - \Delta T.$$

E.g. PKJ 4110E PIHS at 1 m/s:

$$1. ((\frac{1}{0.885}) - 1) \times 100 \text{ W} = 13 \text{ W}$$

$$2. 13 \text{ W} \times 3.8^\circ\text{C/W} = 50^\circ\text{C}$$

$$3. 125^\circ\text{C} - 50^\circ\text{C} = \text{max ambient temperature is } 75^\circ\text{C}$$

The actual temperature will be dependent on several factors such as the PCB size, number of layers and direction of airflow.

Definition of reference temperature T_{P1}

The reference temperature is used to monitor the temperature limits of the product. Temperatures above maximum T_{P1} , measured at the reference point P1 are not allowed and may cause degradation or permanent damage to the product. T_{P1} is also used to define the temperature range for normal operating conditions. T_{P1} is defined by the design and used to guarantee safety margins, proper operation and high reliability of the product.

PKJ 4000E series Direct Converters
 Input 36-75 V, Output up to 30 A / 100 W

EN/LZT 146 383 R4A September 2011

© Ericsson AB

Connections

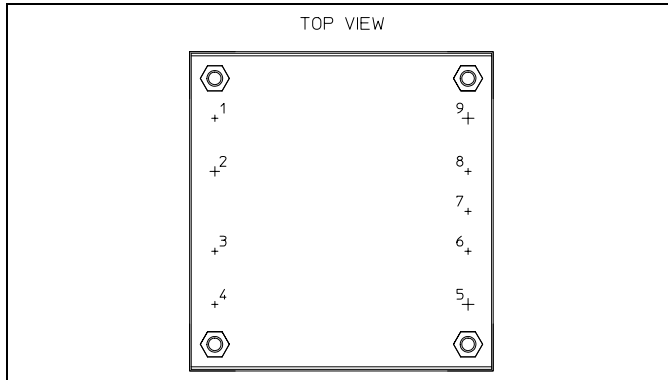

Pin	Designation	Function
1	+ In	Positive input
2	RC	Remote control
3		No pin
4	- In	Negative input
5	- Out	Negative output
6	- Sense	Negative sense
7	Vadj	Output voltage adjust
8	+ Sense	Positive sense
9	+ Out	Positive output

PKJ 4000E series Direct Converters
 Input 36-75 V, Output up to 30 A / 100 W

EN/LZT 146 383 R4A September 2011

© Ericsson AB

Mechanical Information

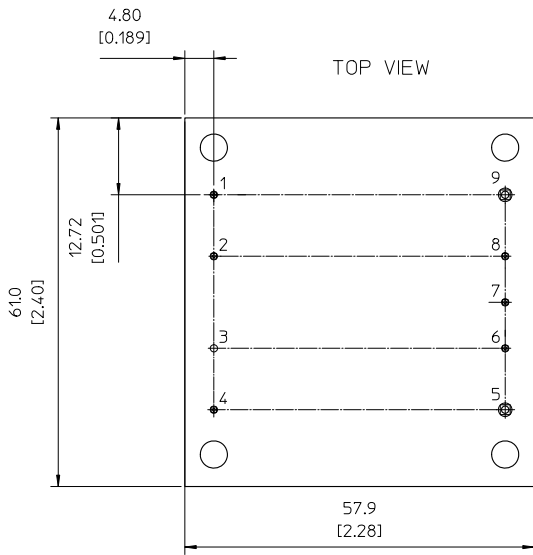
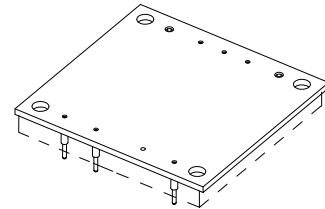
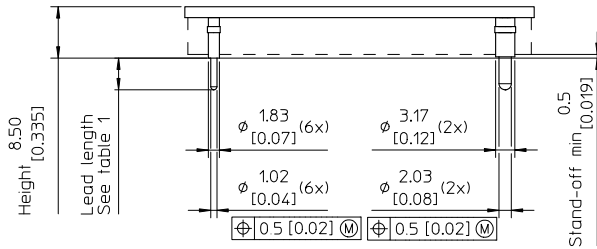

RECOMMENDED FOOTPRINT - TOP VIEW

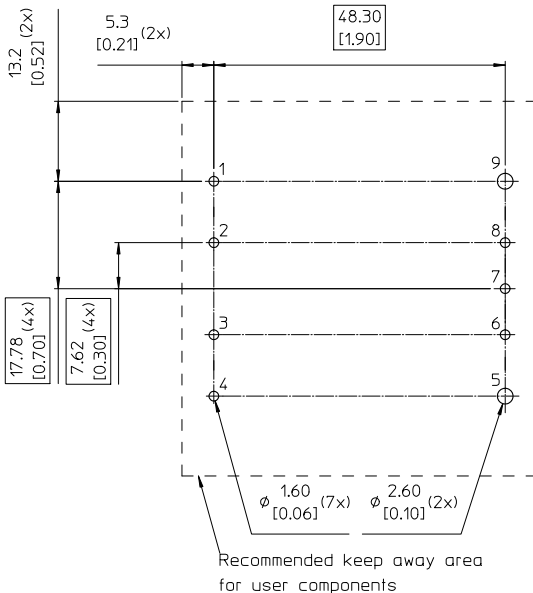
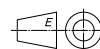

Table 1

Pin option	Lead Length
Standard	5.25 [0.206]
LA	3.69 [0.145] cui

Pins:
 Material: Brass
 Plating: 0.1 μ m Gold over 2 μ m Nickel

Weight: Typical 35 g
 All dimensions in mm [inch].
 Tolerances unless specified
 x.x mm \pm 0.50 [0.02], x.xx mm \pm 0.25 [0.01]
 (not applied on footprint or typical values)



PKJ 4000E series Direct Converters
 Input 36-75 V, Output up to 30 A / 100 W

EN/LZT 146 383 R4A September 2011

© Ericsson AB

Mechanical Information- Base plate version

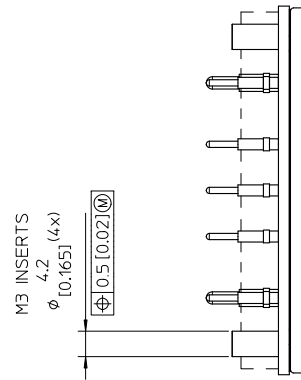
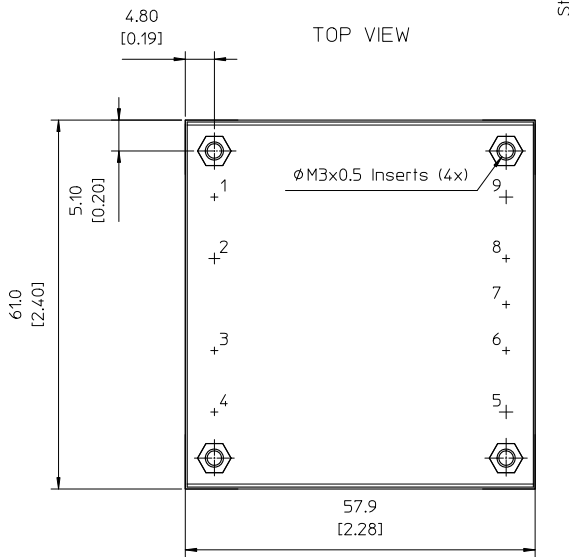
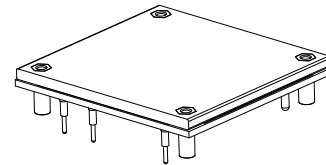
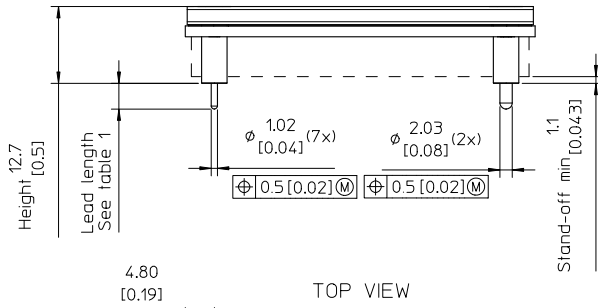
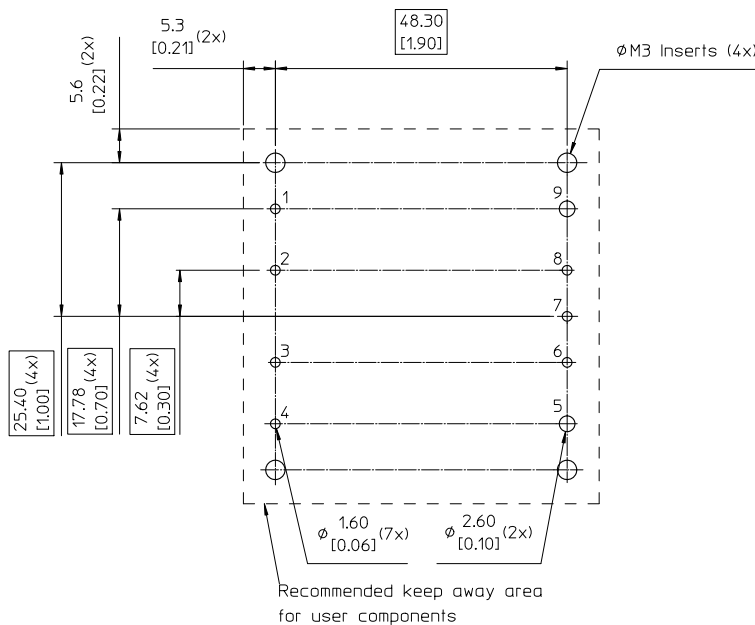

Table 1

Pin option	Lead Length
Standard	4.35 [0.171]
LA	3.69 [0.145] cut



Case:
 Material: Aluminium
 - For screw attachment apply mounting torque of max 0.44 Nm [3.9 lbf in].

Pins:
 Material: Brass
 Plating: 0,1 μ m Gold over 2 μ m Nickel

Weight: Typical 67 g
 All dimensions in mm [inch].
 Tolerances unless specified
 x.x mm \pm 0.50 [0.02], x.xx mm \pm 0.25 [0.01]
 (not applied on footprint or typical values)



PKJ 4000E series Direct Converters
 Input 36-75 V, Output up to 30 A / 100 W

EN/LZT 146 383 R4A September 2011

© Ericsson AB

Soldering Information – Through hole mounting

The product is intended for through hole mounting in a PCB. When wave soldering is used, the temperature on the pins is specified to maximum 270 °C for maximum 10 seconds.

Maximum preheat rate of 4 °C/s and temperature of max 150 °C is suggested. When hands soldering care should be taken to avoid direct contact between the hot soldering iron tip and the pins for more than a few seconds in order to prevent overheating.

A no-clean (NC) flux is recommended to avoid entrapment of cleaning fluids in cavities inside of the DC/DC power module. The residues may affect long time reliability and isolation voltage.

Delivery package information – Open frame

The products are delivered in antistatic trays.

Tray specifications	
Material	Polystyrene, dissipative
Surface resistance	$10^3 < \Omega/\text{square} < 10^6$
Bake ability	The trays are not bakeable
Tray capacity	10 products/tray
Tray height	21 mm [0.827 inch]
Box capacity	50 products (5 full trays/box)
Tray weight	133 g empty, 483 g full

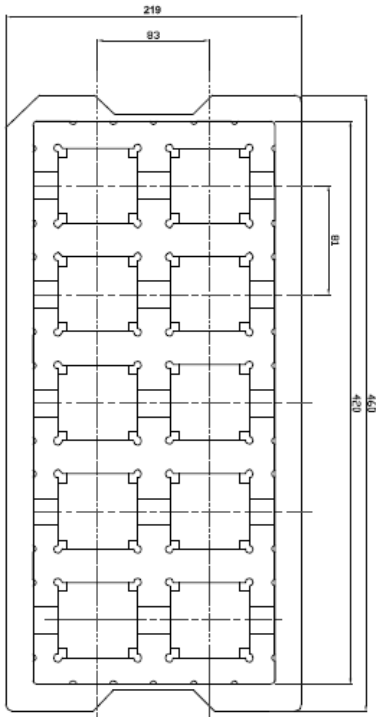

Delivery package information – Base plate option

The products are delivered in antistatic trays.

Tray specifications	
Material	PET, dissipative
Surface resistance	$10^5 < \Omega/\text{square} < 10^{12}$
Bake ability	The trays are not bakeable
Tray capacity	10 products/tray
Tray height	25.0 mm [0.984 inch]
Box capacity	50 products (5 full trays/box)
Tray weight	150 g empty 820 g full

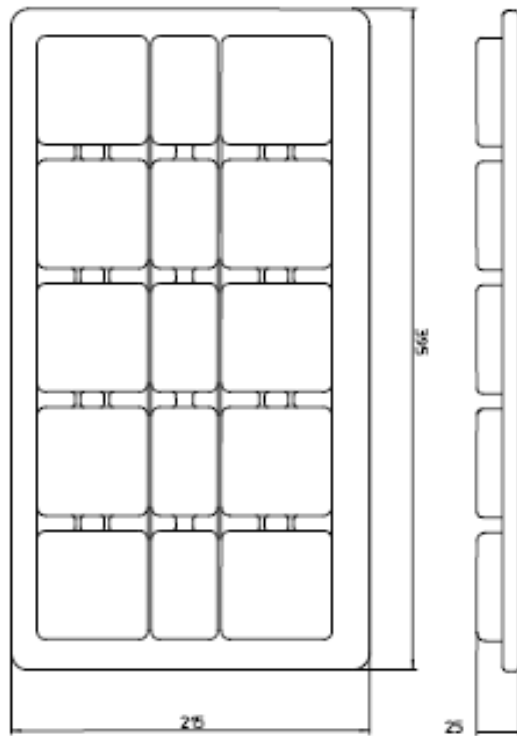

PKJ 4000E series Direct Converters
 Input 36-75 V, Output up to 30 A / 100 W

EN/LZT 146 383 R4A September 2011

© Ericsson AB

Product Qualification Specification

Characteristics			
External visual inspection	IPC-A-610		
Change of temperature (Temperature cycling)	IEC 60068-2-14 Na	Temperature range Number of cycles Dwell/transfer time	-40 to +100 °C 1000 15 min/0-1 min
Cold (in operation)	IEC 60068-2-1 Ad	Temperature T _A Duration	-45 °C 72 h
Damp heat	IEC 60068-2-67 Ca	Temperature Humidity Duration	+85 °C 85 % RH 1000 hours
Dry heat	IEC 60068-2-2 Ba	Temperature Duration	+125 °C 1000 h
Electrostatic discharge susceptibility	IEC 61340-3-1, JESD 22-A114 IEC 61340-3-2, JESD 22-A115	Human body model (HBM) Machine model (MM)	Class 2, 2000 V Class 3, 200 V
Immersion in cleaning solvents	IEC 60068-2-45 XA Method 2	Water Glycol ether Isopropyl alcohol	+55 ±5 °C +35 ±5 °C +35 ±5 °C
Mechanical shock	IEC 60068-2-27 Ea	Peak acceleration Duration Pulse shape Directions Number of pulses	100 g 6 ms Half sine 6 18 (3 + 3 in each perpendicular direction)
Moisture reflow sensitivity	J-STD-020C	Level 1 (SnPb-eutectic) Level 3 (Pb Free)	225 +0 -5 °C 260 +0 -45 °C
Operational life test	MIL-STD-202G method 108A	Duration	1000 h
Resistance to soldering heat	IEC 60068-2-20 Tb Method 1A	Solder temperature Duration	270 °C 10-13 s
Robustness of terminations	IEC 60068-2-21 Test Ua		All leads
Solderability	IEC 60068-2-20 Test Ta	Preconditioning Temperature, SnPb Eutectic Temperature, Pb-free	Ageing for 240 h 85 °C/85 % RH 235 °C 260 °C
Vibration, broad band random	IEC 60068-2-64 Fh method 1	Frequency Spectral density Duration	10 to 500 Hz 0.07 g ² /Hz 10 min in each 3 perpendicular directions

Mouser Electronics

Authorized Distributor

Click to View Pricing, Inventory, Delivery & Lifecycle Information:

[Ericsson Power Modules:](#)

[PKJ4618HEPI](#) [PKJ4618GEPI](#) [PKJ4719EPI](#) [PKJ4810EPI](#) [PKJ4110EPI](#) [PKJ4111EPI](#) [PKJ4113EPI](#) [PKJ4115EPI](#)