

■ Description

U6115 is a low cost and high performance Primary Side Regulation (PSR) controller for offline small power converter applications which can provide very tight output voltage regulation (CV) and output current control (CC) ideal for charging applications. In CV mode, U6115 adopts Multi Mode Control which uses the hybrid of AM (Amplitude Modulation) mode and (Frequency Modulation) FM mode to improve system efficiency and reliability. In CC mode, the IC uses PFM control with line and load CC compensation. The IC can achieve audio noise free operation and optimized dynamic response. The built-in Cable Drop Compensation (CDC) function can provide excellent CV performance. U6115 integrates functions and protections of Under Voltage Lockout (UVLO), VDD over Voltage Protection (VDD OVP), Cycle-by-cycle Current Limiting (OCP), Short Load Protection (SLP), Pin Floating Protection, VDD Clamping, etc.

■ Applications

- Battery Chargers for Cellular Phones
- AC/DC Power Adapter and LED Drivers
- PSR Application :
 - U 6115S: 230VAC : 7.5W & 85-265VAC : 5.5W
 - U 6115D: 230VAC : 15W & 85-265VAC : 12W

■ Pin Configuration

Pin Number	Pin Name	Function
1	VDD	Power Supply Pin of the Chip
2	NC	
3	FB	System feedback pin which regulates both the output voltage in CV mode and output current in CC mode based on the flyback voltage of the auxiliary winding
4	CS	Current Sense Input Pin
5/6	GND	The Ground of the IC
7/8	Drain	The Power BJT Drain

■ Features

- Driver Integrated With 700V BJT Driver
- Multi Mode PSR Control
- Audio Noise Free Operation
- Optimized Dynamic Response
- Low Standby Power <70mW
- $\pm 4\%$ CC and CV Regulation
- Programmable Cable Drop Compensation: (CDC) in CV Mode
- Built-in AC Line & Load CC Compensation
- Build in Protections:
 - Short Load Protection (SLP)
 - Cycle-by-Cycle Current Limiting
 - VDD OVP & UVP & Clamp
 - Leading Edge Blanking (LEB)
 - Pin Floating Protection
 - VDD OVP & Clamp
- Package: U6115S: SOP-8
U6115D: DIP-8

■ Package Information

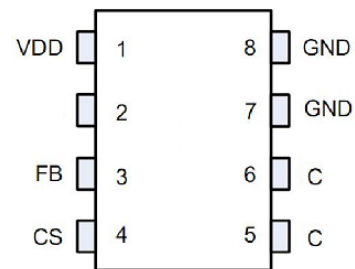

TOP VIEW

■ Typical Application Circuit

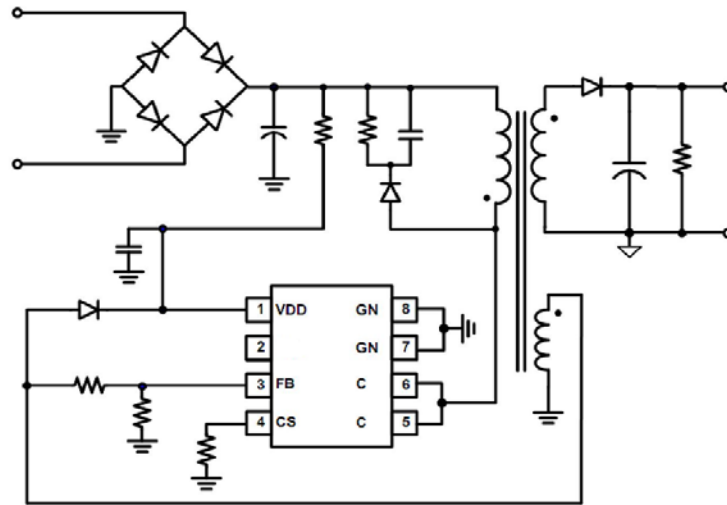

(Charger Application)

■ Block Diagram

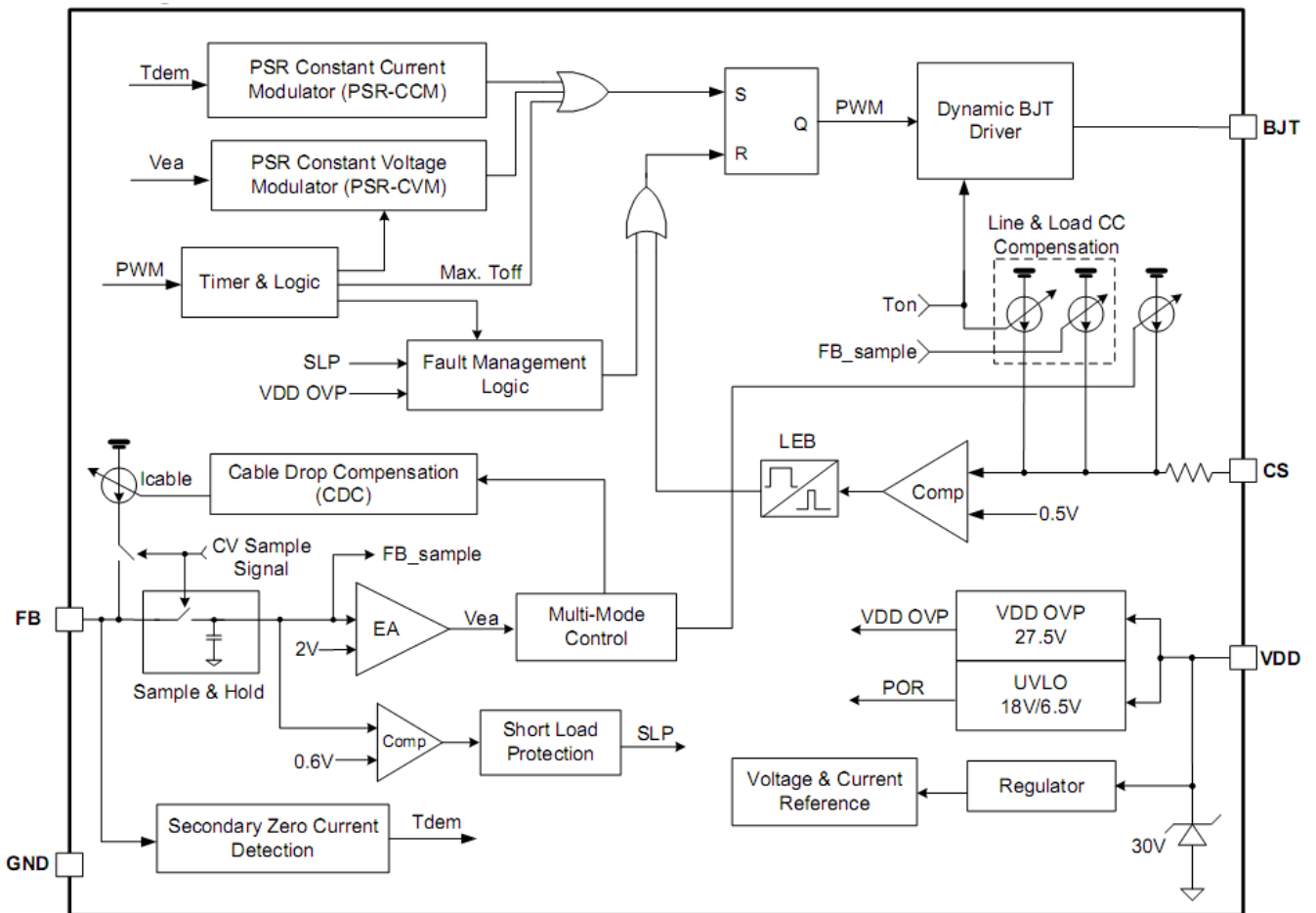

■ Absolute Maximum Ratings (Note 1)

Parameter	Value	Unit
VDD DC Supply Voltage	30	V
VDD DC Clamp Current	10	mA
Drain pin	700	V
CS, SEL voltage range	-0.3 to 7	V
FB voltage range	-0.7 to 7	V
Package Thermal Resistance (SOP-8)	85	°C/W
Package Thermal Resistance (SOP-8)	45	°C/W
Maximum Junction Temperature	150	°C
Operating Temperature Range	-40 to 85	°C
Storage Temperature Range	-65 to 150	°C
Lead Temperature (Soldering, 10sec.)	260	°C
ESD Capability, HBM (Human Body Model)	3	kV
ESD Capability, MM (Machine Model)	250	V

■ Recommended Operation Conditions (Note 2)

Parameter	Value	Unit
Supply Voltage, VDD	7-24	V
Operating Temperature Range	-40 to 85	°C
Storage Temperature Range	-65 to 150	°C
Maximum Switching Frequency @ Full Loading	70	KHz
Minimum Switching Frequency @ Full Loading	35	KHz

■ Electrical Characteristics (T_A = 25°C, VDD=20V, if not otherwise noted)

Parameter	Symbol	Test Conditions	Min	Typ	Max	Unit
Supply Voltage Section(VDD Pin)						
Start-up current into VDD pin	I _{VDD_ST}			3	20	uA
Operation Current	V _{DD_OP}			0.8	1.5	mA
Standby Current	I _{VDD_standby}			0.5	1	mA
VDD Under Voltage Lockout Exit	V _{DD_ON}		16.5	18	19.5	V
VDD Under Voltage Lockout Enter	V _{DD_OFF}		5.5	6.5	7	V
VDD OVP Threshold	V _{DD_OVP}		25	27.5	30	V
VDD Zener Clamp Voltage	V _{DD_Clamp}	I(V _{DD}) = 7 mA	28	30	32	V
Control Function Section (FB Pin)						
Internal Error Amplifier (EA) Reference Input	V _{FB_REF}		1.97	2.0	2.03	V

Short Load Protection (SLP) Threshold	V_{FB_SLP}			0.6		V
Short Load Protection (SLP) Debounce Time	T_{FB_SHORT}			10		ms
Demagnetization Comparator Threshold	V_{FB_DEM}			25		mV
Minimum OFF time	T_{Off_min}	(Note 3)		2		us
Maximum OFF time	T_{Off_max}			5		ms
Maximum Cable Drop compensation current	I_{Cable_max}			60		uA
Current Sense Input Section (CS Pin)						
CS Input Leading Edge Blanking Time	T_{LEB}			500		ns
Current limiting threshold	$V_{cs(max)}$		490	500	510	mV
Over Current Detection and Control Delay	T_{D_OCP}			100		ns
GATE Driver Section (GATE Pin) (Note 3)						
Max. Base Sourcing Current	I_{BJT_max}		25	30	40	mA
Base Sourcing Current after Pre-off	I_{BJT_OFF}		0.5	1	1.5	mA
Output Low Level ON Resistance	R_{dson}			1		ohm
Power BJT Drain Source Breakdown Voltage	V_{BR}			700		V
Power BJT Drain Source Mask Current	I_{pk}			1.3		A

Note:

1. Stresses listed as the above "Maximum Ratings" may cause permanent damage to the device. These are for stress ratings. Functional operation of the device at these or any other conditions beyond those indicated in the operational sections of the specifications is not implied. Exposure to maximum rating conditions for extended periods may remain possibility to affect device reliability.
2. The device is not guaranteed to function outside its operating conditions.
3. Guaranteed by the Design.

■ Characterization Plots

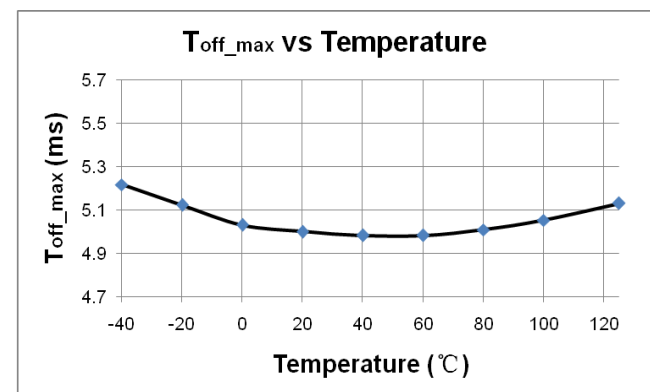
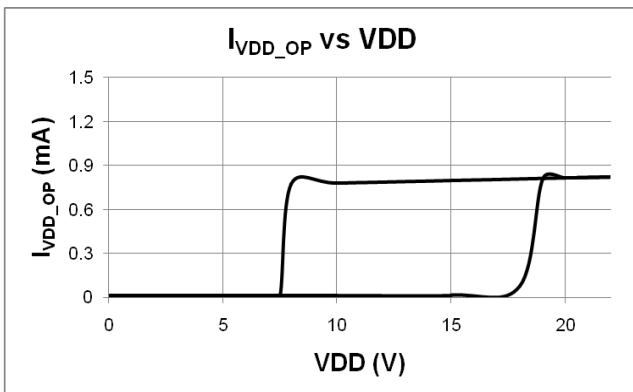
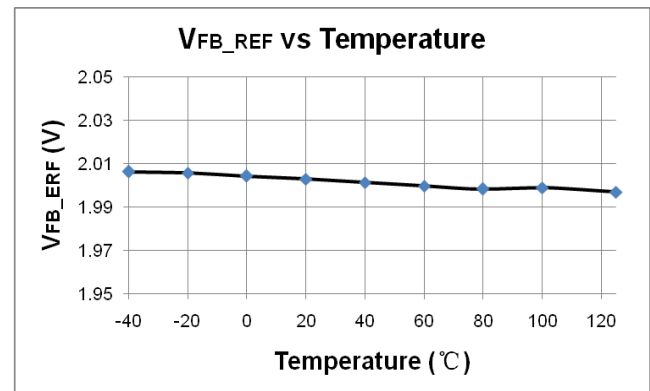
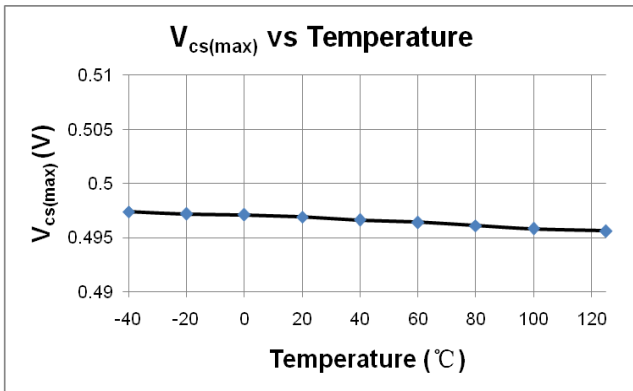
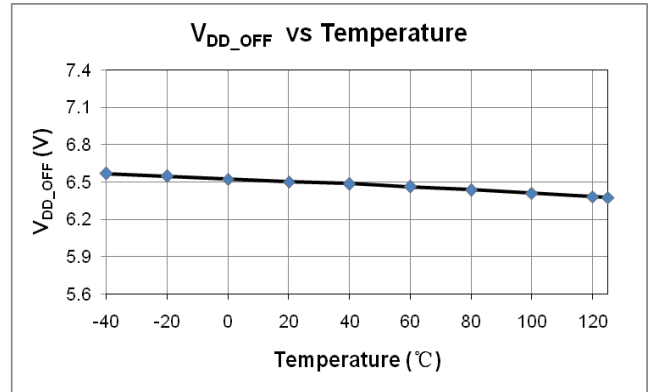
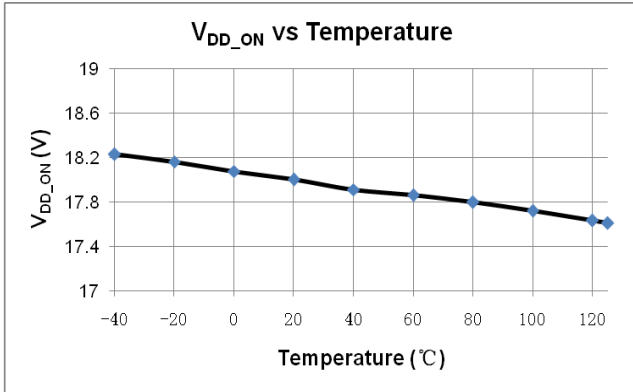

■ Peration Description

U6115 is a high performance, multi mode, highly integrated DCM (Discontinuous Conduction Mode) Primary Side Regulation (PSR) controller. The built-in high precision CV/CC control with high level protection features makes it suitable for offline small power converter applications.

● System Start-Up Operation

Before the IC starts to work, it consumes only startup current (typically 3uA) which allows a large value startup resistor to be used to minimize the power loss and the current flowing through the startup resistor charges the VDD hold-up capacitor from the high voltage DC bus. When VDD reaches UVLO turn-on voltage of 18V (typical), U6115 begins switching and the IC operation current is increased to be 1mA (typical). The hold-up capacitor continues to supply VDD before the auxiliary winding of the transformer takes the control of VDD voltage.

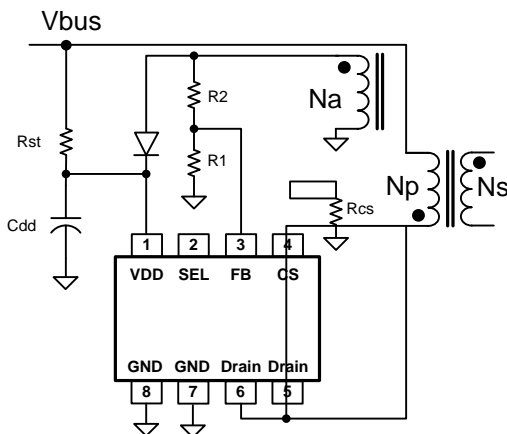

Fig.1

Once U6115 enters very low frequency FM (Frequency Modulation) mode, the operating current is reduced to be 0.8mA typically, which helps to reduce the standby power loss.

● PSR Constant Voltage Modulation (PSR-CVM)

In primary side control, the output voltage is sensed on the auxiliary winding during the transfer of transformer energy to the secondary. Fig.2 illustrates the CV sampling signal timing waveform in U6115. As shown in Fig.2, it is clear that there is a down slope representing a decreasing total rectifier Vf and its voltage drop as the secondary current decreases to zero. To achieve an accurate representation of the secondary output voltage on the auxiliary winding, the CV sampling signal blocks the leakage inductance reset and ringing. When the CV sampling process is over, the internal sample/hold (S&H) circuit captures the error signal and amplifies it through the internal Error Amplifier (EA). The output of EA is sent to the Primary Side Constant Voltage Modulator (PSR-CVM) for CV control. The internal reference voltage for EA is trimmed to 2V with high accuracy.

During the CV sampling process, an internal variable current source is flowing to FB pin for Cable Drop Compensation (CDC). Thus, there is a step at FB pin in the transformer demagnetization process, as shown in Fig.2. Fig.2 also illustrates the equation for “demagnetization plateau”, where Vo and VF is the output voltage and diode forward voltage; R1 and R2 is the resistor divider connected from the auxiliary winding to FB Pin, Ns and Na are secondary winding and auxiliary winding respectively.

When system enters over load condition, the output voltage falls down and the FB sampled voltage should be lower than 2V internal reference which makes system enter CC Mode automatically.

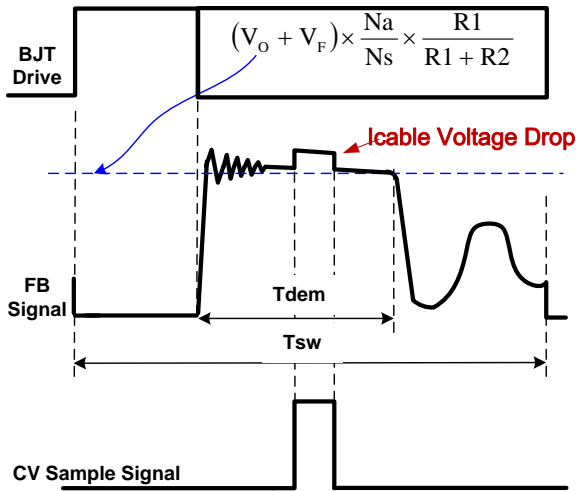

Fig.2

● PSR Constant Current Modulation (PSR-CCM)

Timing information at the FB pin and current information at the CS pin allow accurate regulation of the secondary average current. The control law dictates that as power is increased in CV regulation and approaching CC regulation the primary peak current is at $I_{pp(max)}$, as shown in Fig.3.

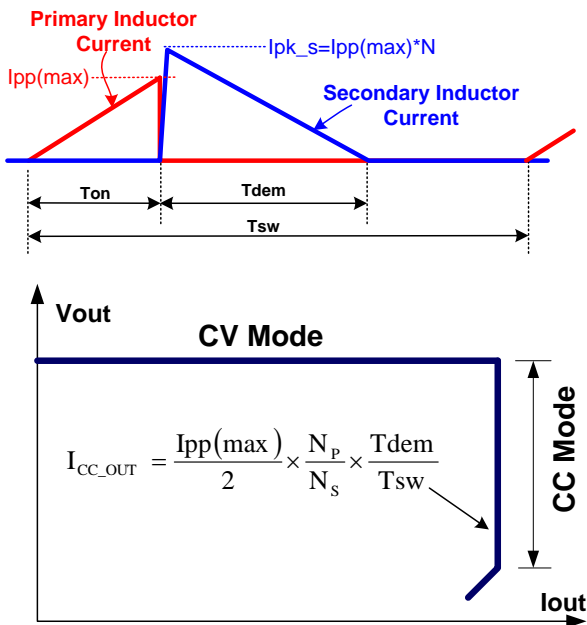

Fig.3

Referring to Fig.3 above, the primary peak current,

transformer turns ratio, secondary demagnetization time (T_{dem}), and switching period (T_{sw}) determines the secondary average output current I_{out} . Ignoring leakage inductance effects, the equation for average output current is shown in Fig.3. When the average output current I_{out} reaches the regulation reference in the Primary Side Constant Current Modulator (PSR-CCM) block, the IC operates in pulse frequency modulation (PFM) mode to control the output current at any output voltage at or below the voltage regulation target as long as the auxiliary winding can keep VDD above the UVLO turn-off threshold.

In U 6115 , the ratio between T_{dem} and T_{sw} in CC mode is 1/2. Therefore, the average output current can be expressed as:

$$I_{CC_OUT}(mA) \cong \frac{1}{4} \times N \times \frac{500mV}{R_{cs}(\Omega)}$$

In the equation above,

N---The turn ratio of primary side winding to secondary side winding.

Rcs--- the sensing resistor connected between the power BJT emitter to GND. I

● Multi Mode Control in CV Mode

To meet the tight requirement of averaged system efficiency and no load power consumption, a hybrid of frequency modulation (FM) and amplitude modulation (AM) is adopted in U6115 which is shown in the Fig 4.

Around the full load, the system operates in FM mode. When normal to light load conditions, the IC operates in FM+AM mode to achieve excellent regulation and high efficiency. When the system is near zero loading, the IC operates in FM again for standby power reduction. In this way, the no-load consumption can be less than 70mW.

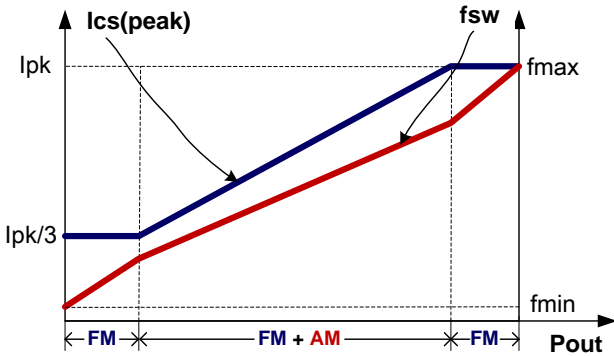

Fig.4

● Programmable Cable Drop Compensation (CDC) in CV Mode

In smart phone charger application, the battery is always connected to the adapter with a cable wire which can cause several percentages of voltage drop on the actual battery voltage. In U6115, an offset voltage is generated at FB pin by an internal current source (modulated by CDC block, as shown in Fig.5) flowing into the resistor divider. The current is proportional to the switching period, thus, it is inversely proportional to the output power P_{out} . Therefore, the drop due the cable loss can be compensated. As the load decreases from full loading to zero loading, the offset voltage at FB pin will increase. By adjusting the resistance of R1 and R2 (as shown in Fig.), the cable loss compensation can be programmed. The percentage of maximum compensation is given by

$$\frac{\Delta V(cable)}{V_{out}} \approx \frac{I_{cable_max} \times (R1/R2)}{V_{FB_REF}} \times 100\%$$

For example, $R1=3K \Omega$, $R2=18K \Omega$, The percentage of maximum compensation is given by:

$$\frac{\Delta V(cable)}{V_{out}} = \frac{60\mu A \times (3K/18K)}{2V} \times 100\% = 7.7\%$$

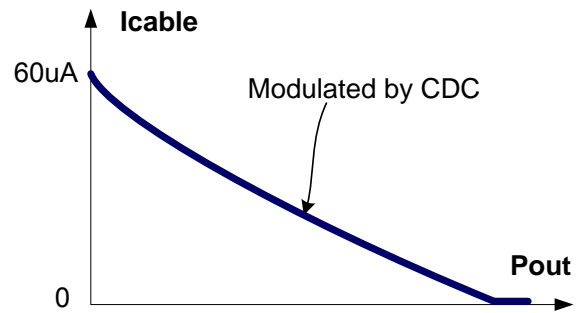
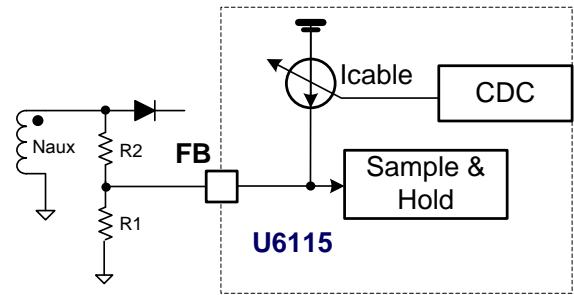

Fig.5

● Optimized Dynamic Response

In U6115, the dynamic response performance is optimized to meet USB charge requirements.

● Audio Noise Free Operation

As mentioned above, the multi-mode CV control with a hybrid of FM and AM provides frequency modulation. An internal current source flowing to CS pin realizes CS peak voltage modulation. In U6115, the optimized combination of frequency modulation and CS peak voltage modulation algorithm can provide audio noise free operation from full loading to zero loading.

● Dynamic BJT Base Drive

U6115 drives a power BJT with dynamic base drive control to optimize efficiency. The BJT base drive current ranges from 10mA to 30mA (typical), and is dynamically controlled according to the power supply load change. The higher the output power, the higher the based current. Specifically, the base current is related to CS peak voltage, as shown in

Fig.6

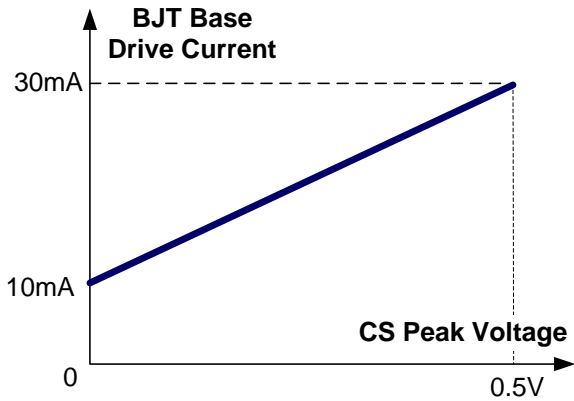

Fig.6

- **Short Load Protection (SLP)**

In U6115, the output is sampled on FB pin and then compared with a threshold of UVP (0.6V typically) after an internal blanking time (10ms typical).

In U6115, when sensed FB voltage is below 0.6V, the IC will enter into Short Load Protection (SLP) mode, in which the IC will enter into auto recovery protection mode.

- **VDD Over Voltage Protection (OVP) and Zener Clamp**

When VDD voltage is higher than 27.5V (typical), the IC will stop switching. This will cause VDD fall down to be lower than VDD_OFF (typical 6.5V) and then the system will restart up again. An internal 30V (typical) zener clamp is integrated to prevent the IC from damage.

■ Package Dimensions

SOP8

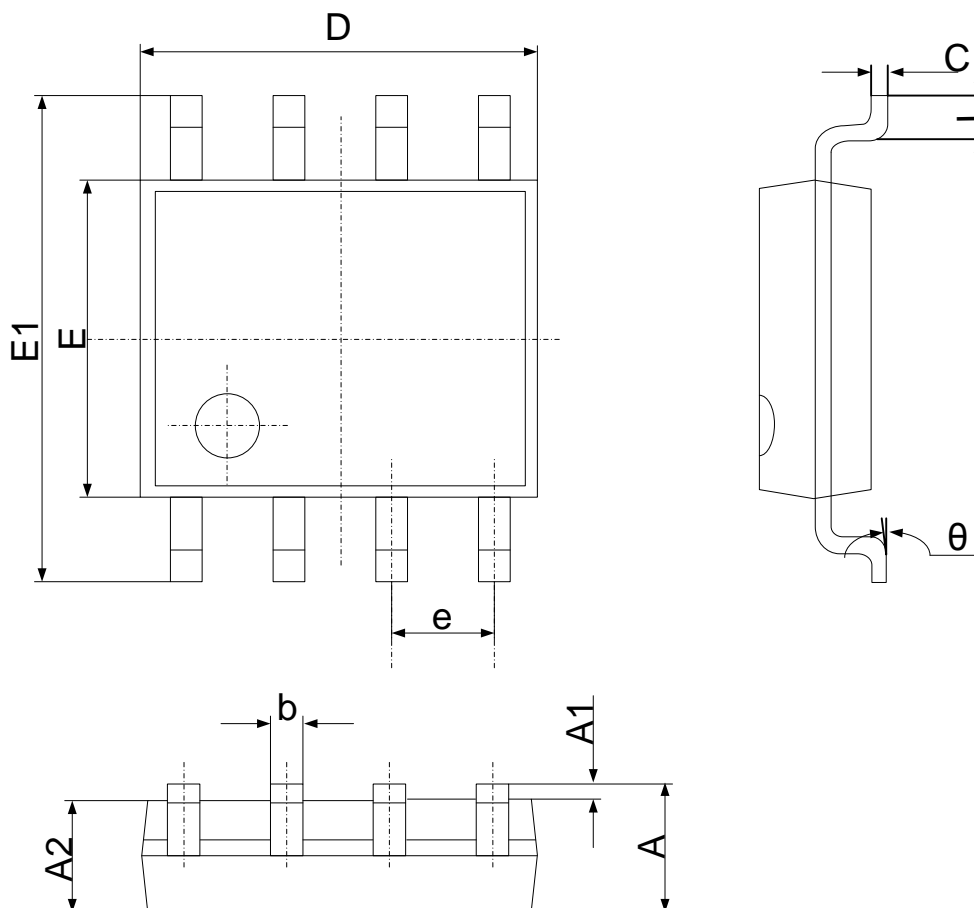

Symbol	Dimensions In Millimeters		Dimensions In Inches	
	Min	Max		Min
A	1.350	1.750	A	1.350
A1	0.100	0.250	A1	0.100
A2	1.350	1.550	A2	1.350
b	0.330	0.510	b	0.330
c	0.170	0.250	c	0.170
D	4.700	5.100	D	4.700
e	1.270 (BSC)	0.050 (BSC)	e	1.270 (BSC)
E1	5.800	6.200	E1	5.800
E	3.800		4.000	
L	0.400	1.270	L	0.400
theta	0°	8°	theta	0°

DIP8

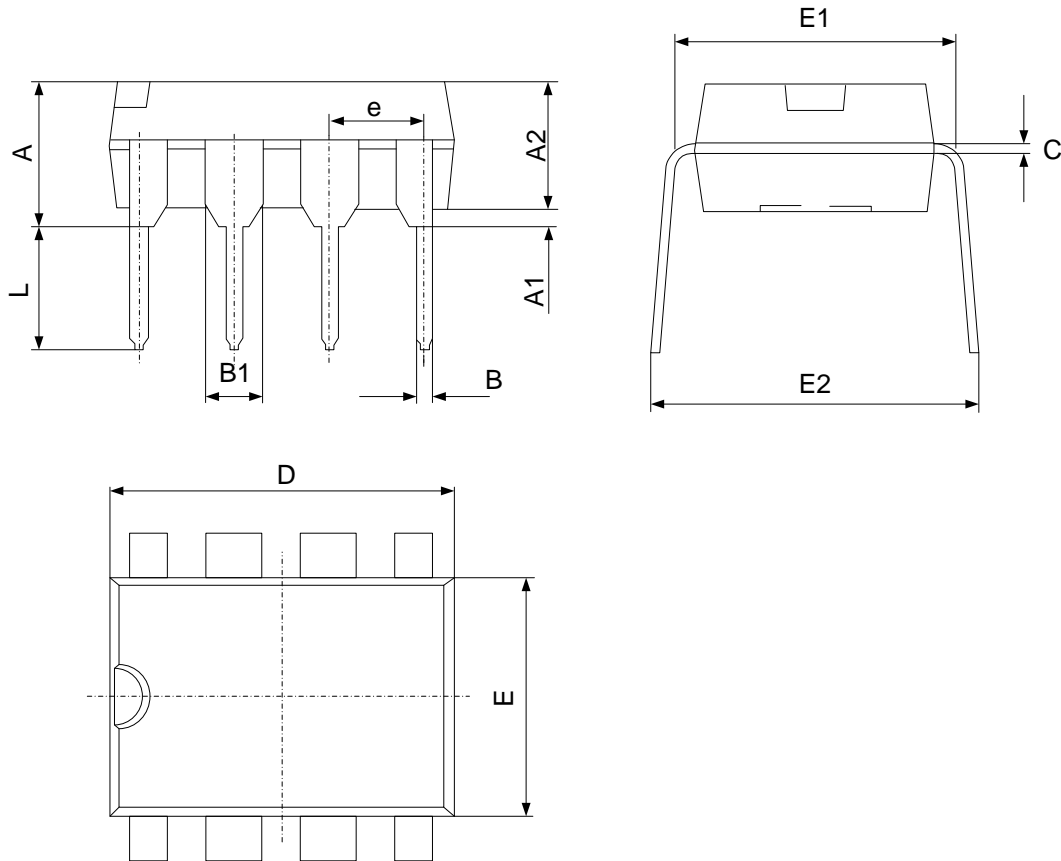

Symbol	Dimensions In Millimeters		Dimensions In Inches	
	Min	Max	Min	Max
A	3.710	5.334	0.146	0.210
A1	0.381		0.015	
A2	3.175	3.600	0.125	0.142
B	0.350	0.650	0.014	0.026
B1	1.524 (BSC)		0.06 (BSC)	
C	0.200	0.360	0.008	0.014
D	9.000	10.160	0.354	0.400
E	6.200	6.600	0.244	0.260
E1	7.320	7.920	0.288	0.312
e	2.540 (BSC)		0.1 (BSC)	
L	2.921	3.810	0.115	0.150
E2	8.200	9.525	0.323	0.375