

64-Bit MIPS RISC Microprocessors with Integrated L2 Cache

FEATURES

- Dual issue symmetric superscalar microprocessor with instruction prefetch optimized for system level price/performance:
 - 466, 533, 600 MHz operating frequency.
 - >1380 Dhrystone 2.1 MIPS @ 600 MHz.
- High-performance system interface:
 - 1600 Mbyte/s peak throughput.
 - 200 MHz maximum frequency using HSTL signaling on the SysAD bus.
 - Multiplexed address/data (SysAD) bus supports 1.5 V, 2.5 V, 3.3 V I/O logic.
 - Processor clock multipliers 2, 2.5, 3, 3.5, 4, 4.5, 5, 6, 7, 8, 9.
 - Support for 64- or 32-bit interfaces.
- Integrated primary and secondary caches:
 - All are 4-way set associative with 32-byte line size.
- 16 Kbytes instruction, 16 Kbytes data, 256 Kbytes on-chip secondary.
- Per line cache locking in primaries and secondary.
- Fast Packet Cache™ increases system efficiency in networking applications.
- High-performance floating-point unit - 1600 MFLOPS maximum:
 - Single cycle repeat rate for common single-precision operations and some double-precision operations.
 - Single cycle repeat rate for single-precision combined multiply-add operations.
 - Two cycle repeat rate for double-precision multiply and double-precision combined multiply-add operations.
- MIPS IV superset instruction set architecture:
 - Data PREFETCH instruction allows the processor to overlap cache miss latency and instruction execution.
- Single-cycle floating-point multiply-add.
- Integrated memory management unit:
 - Fully associative joint TLB (shared by I and D translations).
 - 64/48 dual entries map 128/96 pages.
 - Variable page size.
- Embedded application enhancements:
 - Specialized DSP integer Multiply-Accumulate instructions, (MAD/MADU) and three-operand multiply instruction (MUL).
 - I&D Test/Break-point (Watch) registers for emulation & debug.
 - Performance counter for system and software tuning & debug.
 - 14 fully prioritized vectored interrupts - 10 external, 2 internal, 2 software.

Device	CPU Frequency (MHz)	I/D Cache	Integrated L2 Cache Support	External Bus Width	External Bus Frequency (MHz)	VccInt (V)	VccIO (V)	Package
RM7035C	466,533,600	16KB/16KB	256 KB	32-bit	200	1.3	2.5/3.3	128-ExposedPad™
RM7065C	466,533,600	16KB/16KB	256 KB	64-bit	200	1.3	2.5/3.3	256-TBGA or 216-ExposedPad™

BLOCK DIAGRAM

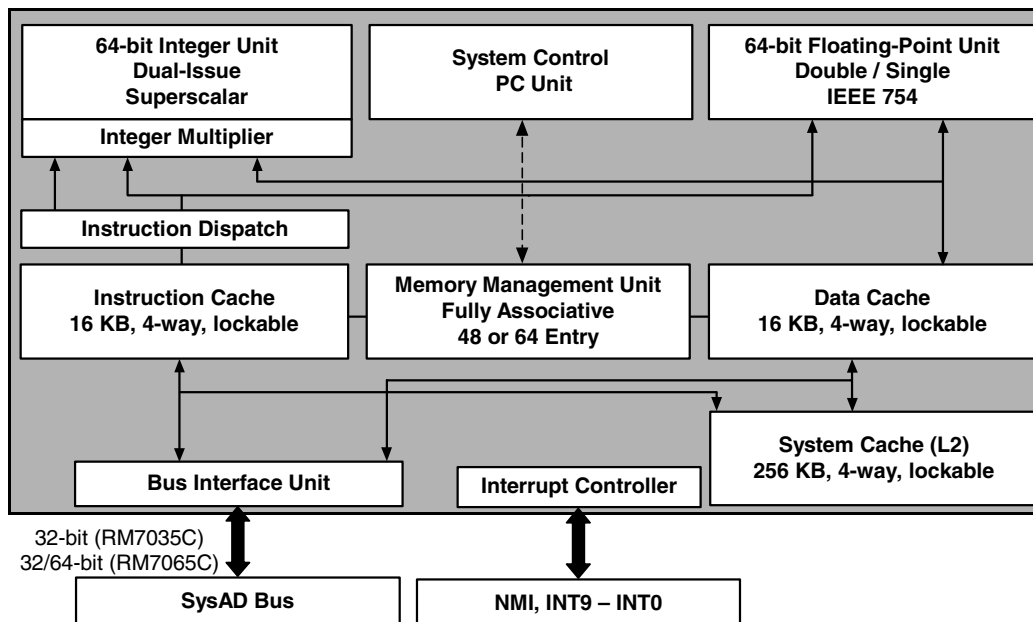

64-Bit MIPS RISC Microprocessors with Integrated L2 Cache

PACKAGING

- Fully Static 0.13µ CMOS design with dynamic power down logic.
- RM7035C is available in a 128-pin ExposedPad™ 20 x 20 mm package, pin-compatible with the RM5231A 128-pin ExposedPad™ product.
- RM7065 package options:
 - 256-pin TBGA package, 27 x 27 mm, pin compatible with the RM7065A TBGA product.
 - 216-pin ExposedPad™ package, 24 x 24 mm, pin compatible with the RM5261A ExposedPad™ product.
- Lead-free (Pb-free) options available.

DEVELOPMENT TOOLS

- Operating Systems:
 - Linux by MontaVista and Red Hat
 - VxWorks by Wind River Systems
 - Nucleus by Accelerated Technology
 - Neutrino by QNX Software Systems

- Compiler Suites
 - GNU
 - MIPS Technologies
 - Green Hills Software
 - Red Hat
- Evaluation Boards and Companion Chips
 - ITE (RM7035C only):
 - System controller: IT8172G
 - Evaluation board: IT8172 PDK-BSP
 - Marvell Semiconductor (RM7065C only):
 - System controllers: MV-64340, GT-64240, GT-96122
 - Evaluation platforms: EV-64340, EV-64240. Both Marvell evaluation boards feature the RM7000C, which features the same CPU core as the RM7065C. The RM7065C does not provide L3 cache functionality.

- Momentum Computer
 - Evaluation platform: Ocelot C. Features RM7000C.
- Logic Analyzers and Emulation
 - HP
 - Tektronix
 - Corelis
 - Crescent Heart Software

APPLICATIONS

- Voice Gateways
- Multi-Service Access Platforms
- DSLAMs/Access Concentrators
- Remote Access Switches
- Web Switches
- Layer 3 Switches
- Backbone Switches/Routers
- RAIDs
- Set Top Boxes
- Networked Printers
- Cellular Base Stations

TYPICAL APPLICATIONS

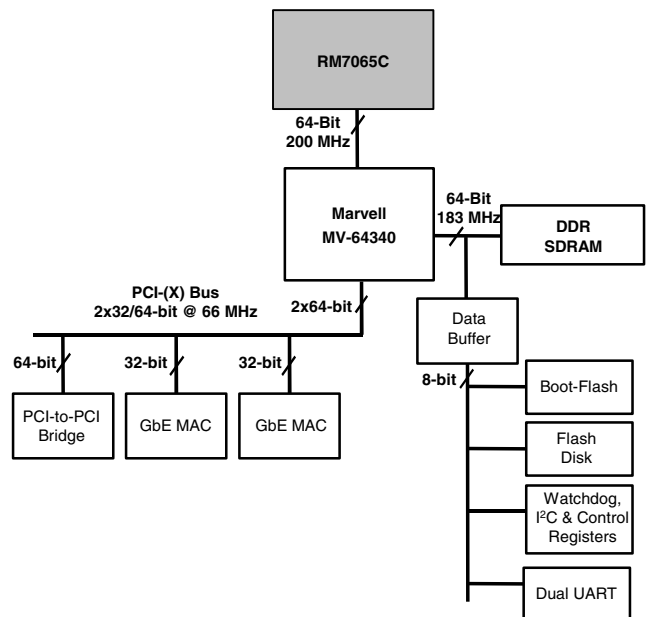
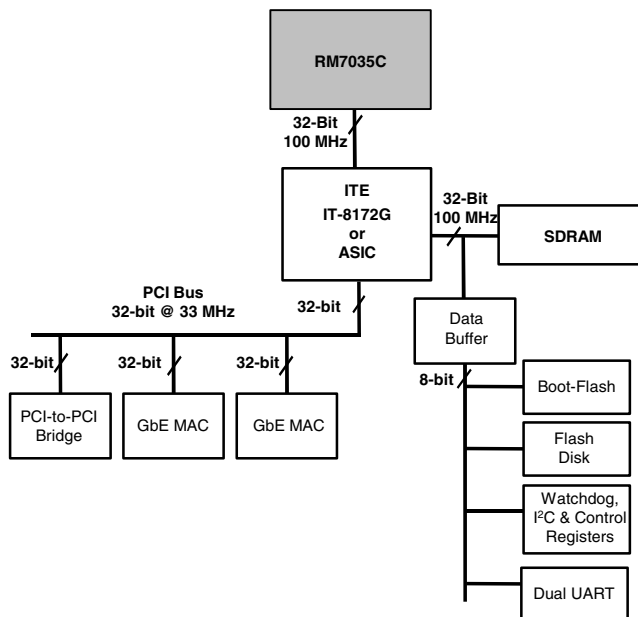

Head Office:
 PMC-Sierra, Inc.
 8555 Baxter Place
 Burnaby, B.C. V5A 4V7
 Canada
 Tel: 1.604.415.6000
 Fax: 1.604.415.6200

To order documentation,
 send email to:
 document@pmc-sierra.com
 or contact the head office,
 Attn: Document Coordinator

All product documentation is available
 on our web site at:
<http://www.pmc-sierra.com>
 For corporate information,
 send email to:
 info@pmc-sierra.com

PMC-2020578 (P2)
 © Copyright PMC-Sierra, Inc. 2003. All
 rights reserved. February 2003.
 For a complete list of PMC-Sierra's
 trademarks and registered trademarks,
 visit: <http://www.pmc-sierra.com/legal/>.
 ExposedPad is a trademark of Amkor
 Technology, Inc. All other trademarks are
 the property of the respective owners.