

# BTN9970LV NovalithIC™ +

## High current PN half-bridge with integrated driver

### Features

- AEC-Q100/Q006 qualified (Grade 1)
- Supply voltage range 8 V - 18 V (max up to 40 V)
- Path resistance of typ. 9.7 mΩ @ 25°C (max. 18.1 mΩ @ 150°C)
- Low quiescent current of max. 3.3 μA @ 85°C
- Protection features: overcurrent, undervoltage, overtemperature
- Overcurrent detection level of 60 A min
- Eight selectable switching slew rates for optimized EME
- Status flag diagnosis with feedback of current sense, temperature and slew rate

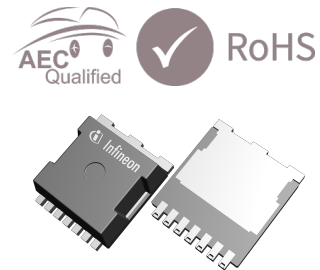

Package	Marking
PG-HSOF-7-1 (STOLL)	BTN9970

### Potential applications

- Automotive 12 V brushed DC Motor
- Fuel pump
- Power liftgate
- HVAC blower

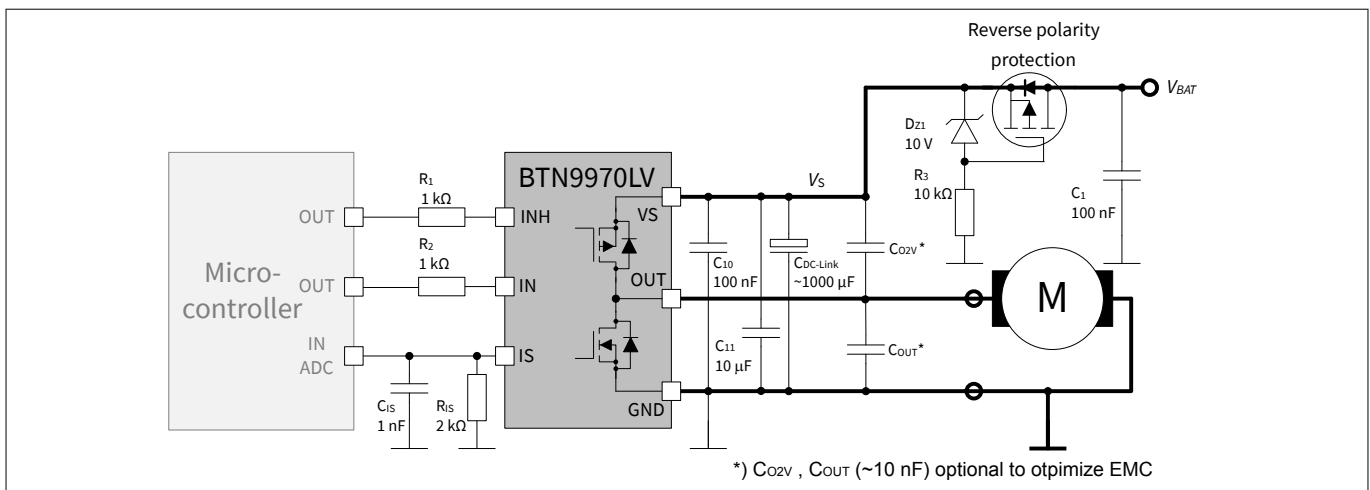

**Figure 1** Typical application

### Product validation

Qualified for automotive applications.  
Product validation according to AEC-Q100.

### Description

The BTN9970LV is an integrated high current half-bridge for motor drive applications. It is part of the integrated half-bridge NovalithIC™+ family containing one p-channel high-side MOSFET and one n-channel low-side MOSFET with an integrated driver IC in one package. Due to the p-channel high-side switch the need for a charge pump is eliminated thus minimizing EME. Interfacing to a microcontroller is made easy by the integrated

# **BTN9970LV NovalithIC™ +** **High current PN half-bridge with integrated driver**

---



## **Description**

driver IC which features logic level inputs, diagnosis with current sense, slew rate adjustment, dead time generation and protection against overtemperature, undervoltage, overcurrent and short circuit.

The BTN9970LV provides a cost optimized solution for protected high current PWM motor drives with very low board space consumption.

## Table of contents

	<b>Features</b> .....	1
	<b>Potential applications</b> .....	1
	<b>Product validation</b> .....	1
	<b>Description</b> .....	1
	<b>Table of contents</b> .....	3
<b>1</b>	<b>Block diagram</b> .....	4
<b>2</b>	<b>Pin configuration</b> .....	6
<b>3</b>	<b>General product characteristics</b> .....	7
3.1	Absolute maximum ratings .....	7
3.2	Functional range .....	9
3.3	Thermal resistance .....	9
<b>4</b>	<b>Block description and characteristics</b> .....	10
4.1	Supply characteristics .....	10
4.2	Power stages .....	11
4.2.1	Switching times .....	16
4.3	Protection functions .....	17
4.3.1	Undervoltage shutdown with restart .....	18
4.3.2	Overtemperature protection .....	19
4.3.3	Overcurrent protection .....	19
4.3.3.1	Current limitation .....	20
4.3.3.2	Switch-OFF with latch .....	20
4.3.4	Short circuit protection .....	21
4.4	Control and diagnostics .....	21
4.4.1	Dead time generation .....	23
4.4.2	Adjustable slew rate .....	23
4.4.3	Status flag diagnosis with current and temperature sense capability .....	24
4.4.3.1	Current sense .....	24
4.4.3.2	Temperature sense and slew rate feedback .....	25
4.4.3.3	Fault feedback .....	26
4.4.4	Truth table .....	26
<b>5</b>	<b>Application information</b> .....	29
<b>6</b>	<b>Package</b> .....	31
<b>7</b>	<b>Revision history</b> .....	32
	<b>Disclaimer</b> .....	33

**1 Block diagram**

**1 Block diagram**

The BTN9970LV is part of the integrated half-bridge NovalithIC™+ family containing three separate chips in one package: one p-channel high-side MOSFET and one n-channel low-side MOSFET together with a driver IC, forming an integrated high current half-bridge. All three chips are mounted on a common lead frame, using the chip-on-chip and chip-by-chip technology. The power switches utilize vertical MOS technologies to ensure optimum ON-state resistance. Due to the p-channel high-side switch the need for a charge pump is eliminated thus minimizing EME. Interfacing to a microcontroller is made easy by the integrated driver IC which features logic level inputs, diagnosis with current sense, slew rate adjustment, dead time generation and protection against overtemperature, overcurrent, undervoltage and short circuit. The BTN9970LV can be combined with other BTN9970LVs to form an H-bridge or a 3-phase drive configuration.

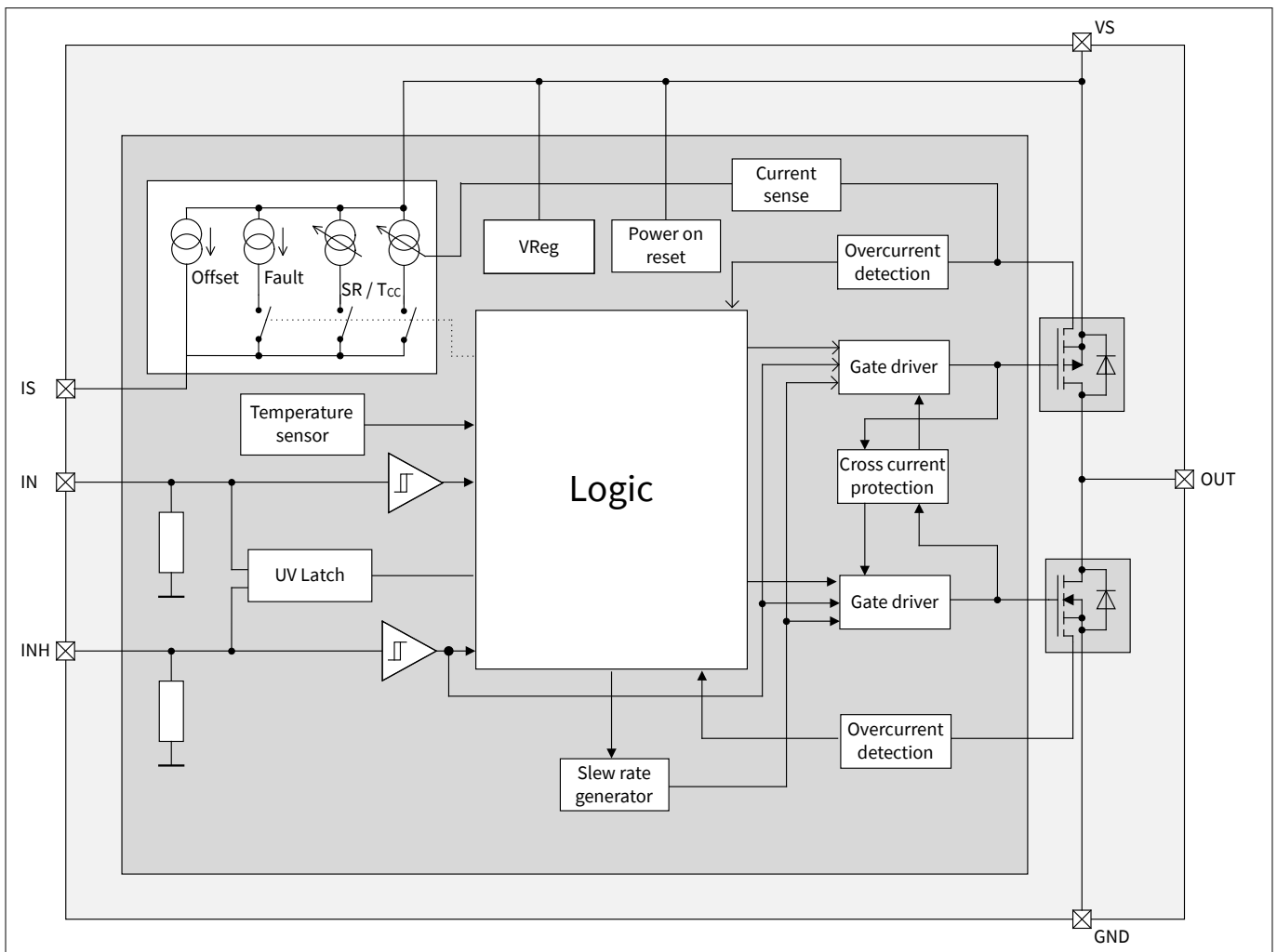

**Figure 2 Block diagram**

Following figure shows the terms used in this datasheet.

**1 Block diagram**

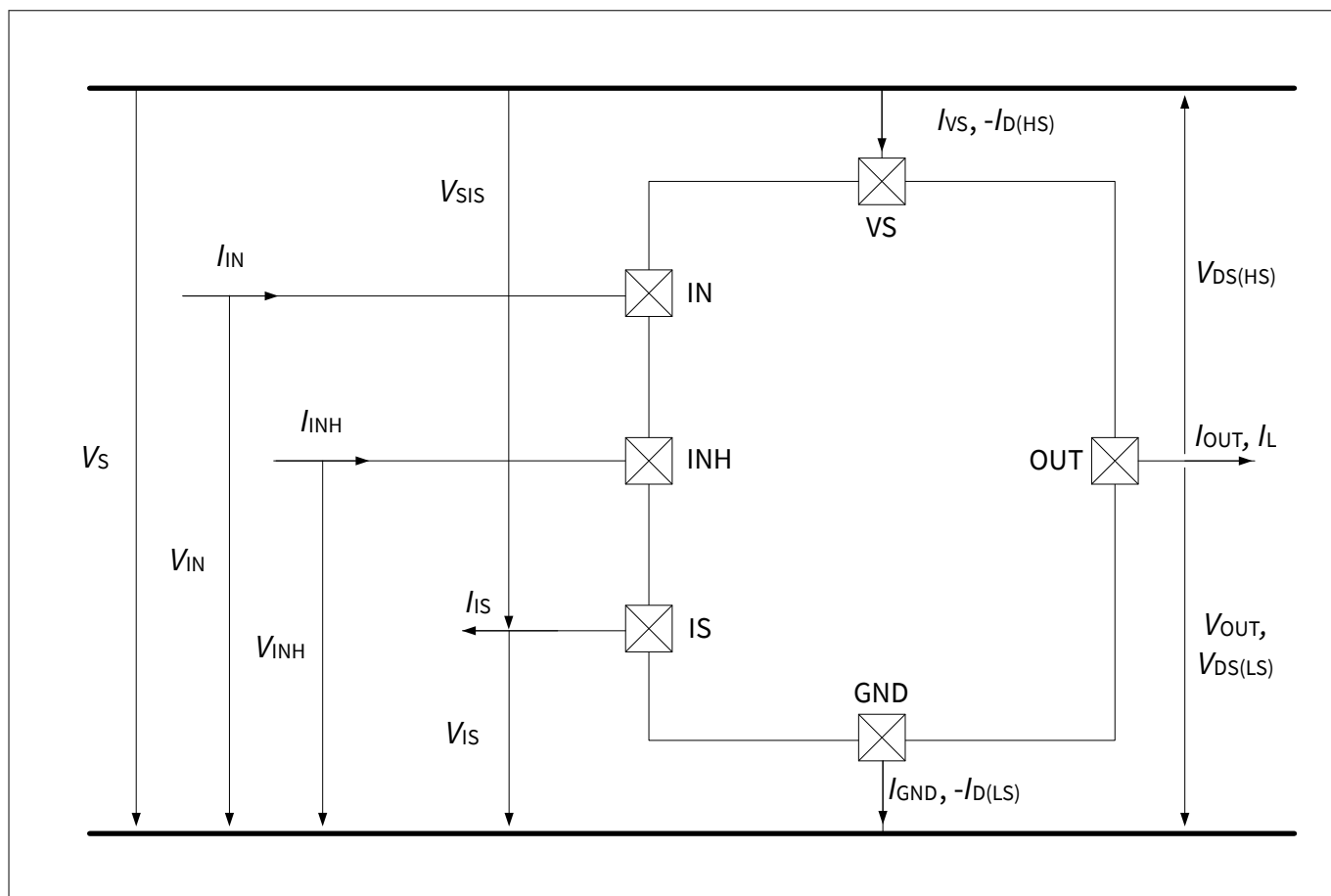

**Figure 3**      **Terms**

**2 Pin configuration**

**2 Pin configuration**

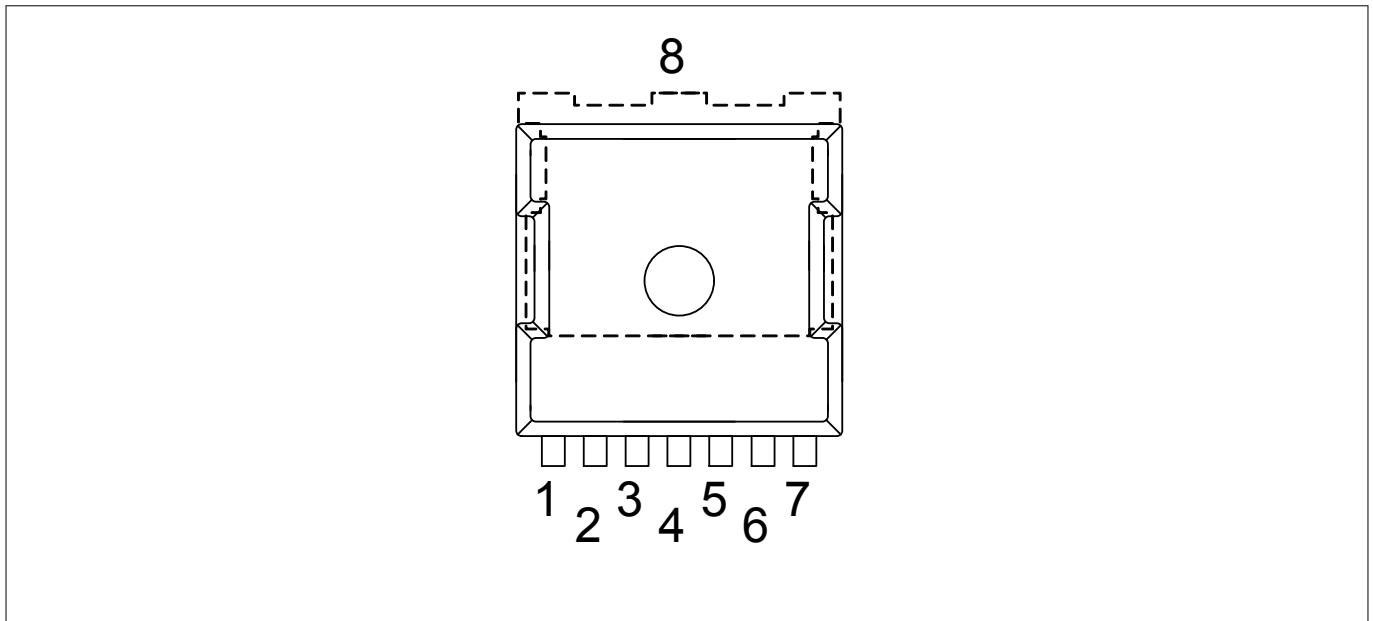

**Figure 4 Pin assignment BTN9970LV (top view)**

**Table 1 Pin definitions and functions**

Pin	Symbol	I/O	Function
<b>1,2</b>	<b>GND</b>	-	<b>Ground</b> <sup>(1)</sup>
3	IN	I	Input Defines whether high- or low-side switch is activated. An internal pull down resistor is connected to this pin.
4	INH	I	Inhibit When set to low device goes in tristate. An internal pull down resistor is connected to this pin.
5	IS	O	Current sense, temperature sense, slew rate level and diagnostics
<b>6,7</b>	<b>VS</b>	-	<b>Supply</b> <sup>(1)</sup>
<b>8 (EP)</b>	<b>OUT</b>	<b>O</b>	<b>Power output of the bridge</b>

1) All terminal pins must be connected together on the PCB. All terminal pins are internally connected together. PCB traces have to be designed to withstand the maximum current which can flow

**Bold type: pin needs power wiring**

**3 General product characteristics**

**3 General product characteristics**

The device is intended to be used in an automotive environment. The circumstances, how the device environment must look like, are described in this chapter.

**3.1 Absolute maximum ratings**

Stresses above the ones listed here may cause permanent damage to the device. Exposure to absolute maximum rating conditions for extended periods may affect device reliability.

**Table 2 Absolute Maximum Ratings**

$T_j = -40^\circ\text{C}$  to  $150^\circ\text{C}$ ; all voltages with respect to ground, positive current flowing into pin (unless otherwise specified) <sup>1)</sup>

Parameter	Symbol	Values			Unit	Note or condition
		Min.	Typ.	Max.		
<b>Voltages</b>						
Supply voltage	$V_S$	-0.3	-	40	V	-
Drain-source voltage high-side	$V_{DS(HS)}$	-40	-	-	V	$T_j \geq 25^\circ\text{C}$
Drain-source voltage high-side	$V_{DS(HS)}$	-38	-	-	V	$T_j < 25^\circ\text{C}$
Drain-source voltage low-side	$V_{DS(LS)}$	-	-	40	V	$T_j \geq 25^\circ\text{C}$
Drain-source voltage low-side	$V_{DS(LS)}$	-	-	38	V	$T_j < 25^\circ\text{C}$
Logic input voltage	$V_{IN}$ $V_{INH}$	-0.3	-	5.5	V	-
Voltage between VS and IS pin	$V_{SIS}$	-0.3	-	40	V	-
Voltage at IS pin	$V_{IS}$	-0.3	-	40	V	-
<b>Currents</b>						
HS drain current	$ I_{D(HS)} $	-	-	$I_{OCH0}$	A	Switch active <sup>2)</sup>
LS drain current	$ I_{D(LS)} $	-	-	$I_{OCL0}$	A	Switch active <sup>2)</sup>
<b>Temperatures</b>						
Junction temperature	$T_j$	-40	-	150	$^\circ\text{C}$	-
Storage temperature	$T_{stg}$	-55	-	150	$^\circ\text{C}$	-
<b>ESD susceptibility</b>						
ESD robustness all pins (HBM)	$ V_{ESD(HBM,local)} $	-	-	2	kV	HBM <sup>3)</sup>
ESD robustness OUT vs GND vs VS (HBM)	$ V_{ESD(HBM,global)} $	-	-	6	kV	HBM <sup>3)</sup>
ESD robustness all pins (CDM)	$ V_{ESD(CDM)} $	-	-	500	TC	CDM <sup>4)</sup>

**(table continues...)**

<sup>1)</sup> Not subject to production test, specified by design.

<sup>2)</sup> Maximum applicable single pulse current depends on  $t_{pulse}$ . See figure maximum single pulse current.

<sup>3)</sup> Human body model “HBM” robustness: class 2 according to AEC-Q100-002.

<sup>4)</sup> Charged device model “CDM” robustness: class C2a according to AEC-Q100-011 Rev D. “TC” corresponds to “test condition” according to AEC-Q100-011.

**3 General product characteristics**

**Table 2 (continued) Absolute Maximum Ratings**

$T_j = -40^{\circ}\text{C}$  to  $150^{\circ}\text{C}$ ; all voltages with respect to ground, positive current flowing into pin (unless otherwise specified) <sup>1)</sup>

Parameter	Symbol	Values			Unit	Note or condition
		Min.	Typ.	Max.		
ESD robustness corner pins (CDM) (pins VS, GND, OUT)	$ V_{\text{ESD(CDM,corner)}} $	-	-	750	TC	CDM <sup>4)</sup>

Latchup Robustness: class II according to AEC-Q100-04

*Note: Integrated protection functions are designed to prevent IC destruction under fault conditions described in the datasheet. Fault conditions are considered as “outside” normal operating range. Protection functions are not designed for continuous repetitive operation.*

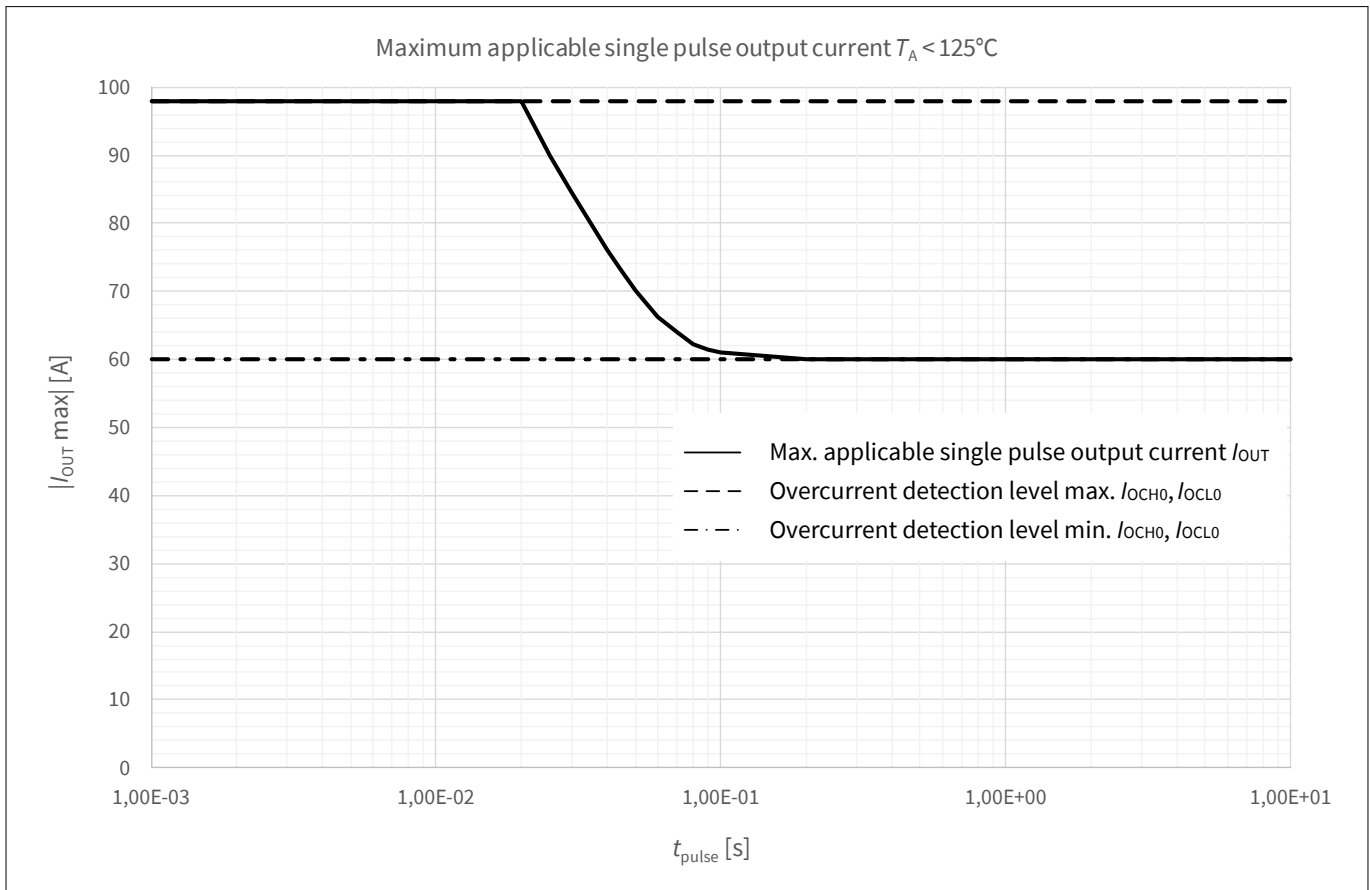

**Figure 5 Maximum single pulse current BTN9970LV**

The diagram shows the maximum single pulse current that can be applied for a given pulse time  $t_{\text{pulse}}$ . The maximum achievable current may be smaller and depends on the overcurrent detection level. Pulse time may be limited due to thermal protection of the device.

<sup>1)</sup> Not subject to production test, specified by design.

<sup>4)</sup> Charged device model “CDM” robustness: class C2a according to AEC-Q100-011 Rev D. “TC” corresponds to “test condition” according to AEC-Q100-011.



**3 General product characteristics**

**3.2 Functional range**

The parameters of the functional range are listed in the following table:

**Table 3 Functional range**

Parameter	Symbol	Values			Unit	Note or condition
		Min.	Typ.	Max.		
Supply voltage range for normal operation	$V_{S(nor)}$	8	–	18	V	<sup>5)</sup>
Extended supply voltage range for operation	$V_{S(ext)}$	4.5	–	40	V	Falling $V_{S(ext)}$ Parameter deviation possible <sup>5)</sup>
Junction temperature	$T_j$	-40	–	150	°C	<sup>5)</sup>

**3.3 Thermal resistance**

This thermal data was generated in accordance with JEDEC JESD51 standards. For more information, go to <https://www.jedec.org/>

**Table 4 Thermal resistance**

Parameter	Symbol	Values			Unit	Note or condition
		Min.	Typ.	Max.		
Thermal resistance junction-case, high-side switch $R_{thJC(HS)} = \Delta T_j(HS)/P_v(HS)$	$R_{thJC(HS)}$	–	0.5	0.7	K/W	<sup>6)</sup>
Thermal resistance junction-case, low-side switch $R_{thJC(LS)} = \Delta T_j(LS)/P_v(LS)$	$R_{thJC(LS)}$	–	0.8	1.1	K/W	<sup>6)</sup>
Thermal resistance junction-ambient	$R_{thJA}$	–	19	–	K/W	<sup>6) 7)</sup>

*Note:* Within the functional or operating range, the IC operates as described in the circuit description. The electrical characteristics are specified within the conditions given in the electrical characteristics table.

<sup>5)</sup> Not subject to production test, specified by design.

<sup>6)</sup> Not subject to production test, specified by design.

<sup>7)</sup> According to Jedec JESD51-2,-5,-7 at natural convection on FR4 2s2p board; The device (chip + package) was simulated on a 76.2 x 114.3 x 1.5 mm board with 2 inner copper layers (2 x 70 μm Cu, 2 x 35 μm Cu). Where applicable a thermal via array under the exposed pad contacted the first inner copper layer.

**4 Block description and characteristics**

**4 Block description and characteristics**

**4.1 Supply characteristics**

**Table 5 Supply characteristics**

$V_S = 8\text{ V to }18\text{ V}$ ,  $T_j = -40^\circ\text{C to }150^\circ\text{C}$ ,  $I_L = 0\text{ A}$ , all voltages with respect to ground, positive current flowing into pin (unless otherwise specified)

Parameter	Symbol	Values			Unit	Note or condition
		Min.	Typ.	Max.		
<b>General</b>						
Supply current	$I_{VS(on)}$	–	2.3	4.5	mA	$V_{INH} = 5\text{ V}$ $V_{IN} = 0\text{ V or }5\text{ V}$ normal operation DC-mode (no fault condition) according to <a href="#">Table 12</a>
Supply current in SR selection mode	$I_{VS(on\_SR)}$	–	2.0	3.2	mA	$V_{INH} = 0\text{ V}$ $V_{IN} = 5\text{ V}$ SR selection mode $I_{VS(on\_SR)} = I_{VS} - I_{IS}$ (no fault condition)
Quiescent current $T_j = 150^\circ\text{C}$	$I_{VS(off)\_150C}$	–	–	75	$\mu\text{A}$	$V_{INH} = V_{IN} = 0\text{ V}$ $T_j = 150^\circ\text{C}$
Quiescent current at $T_j \leq 85^\circ\text{C}$	$I_{VS(off)\_85C}$	–	–	5	$\mu\text{A}$	$V_{INH} = V_{IN} = 0\text{ V}$ $T_j \leq 85^\circ\text{C}$ <sup>8)</sup>
Quiescent current $T_j \leq 85^\circ\text{C}$ and $V_S = 13.5\text{ V}$	$I_{VS(off)\_85C\_13.5V}$	–	–	3.3	$\mu\text{A}$	$V_{INH} = V_{IN} = 0\text{ V}$ $V_S = 13.5\text{ V}$ $T_j \leq 85^\circ\text{C}$ <sup>8)</sup>

<sup>8</sup> Not subject to production test, specified by design.

**4 Block description and characteristics**

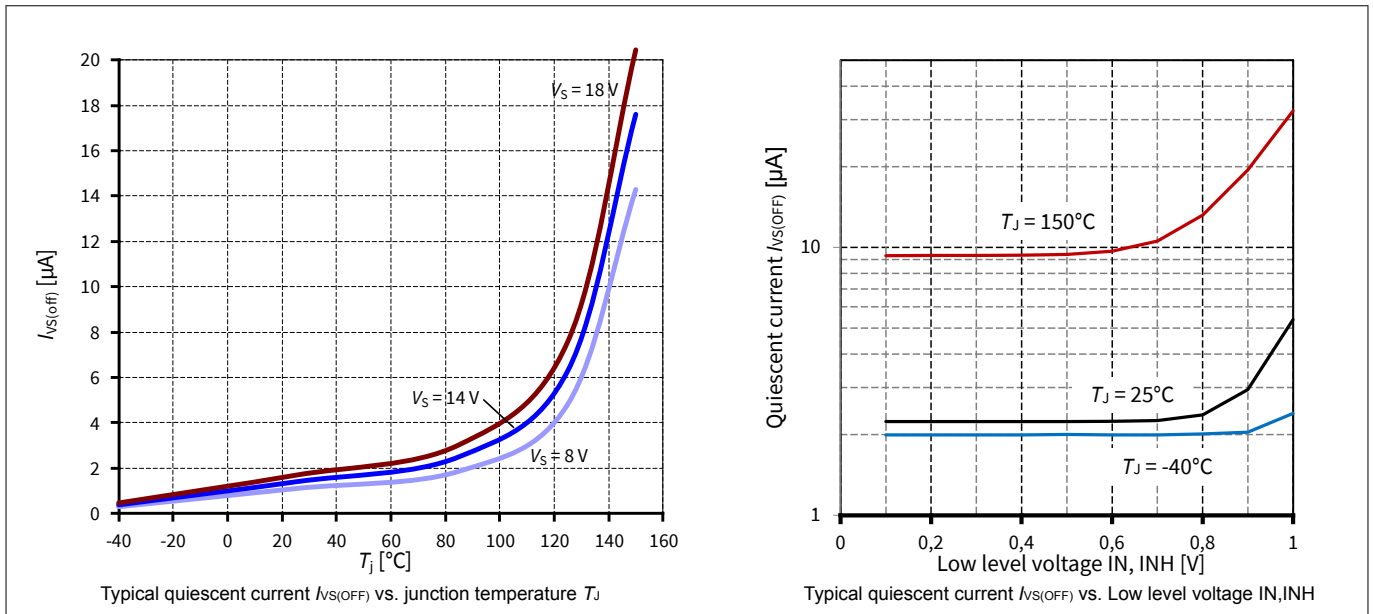
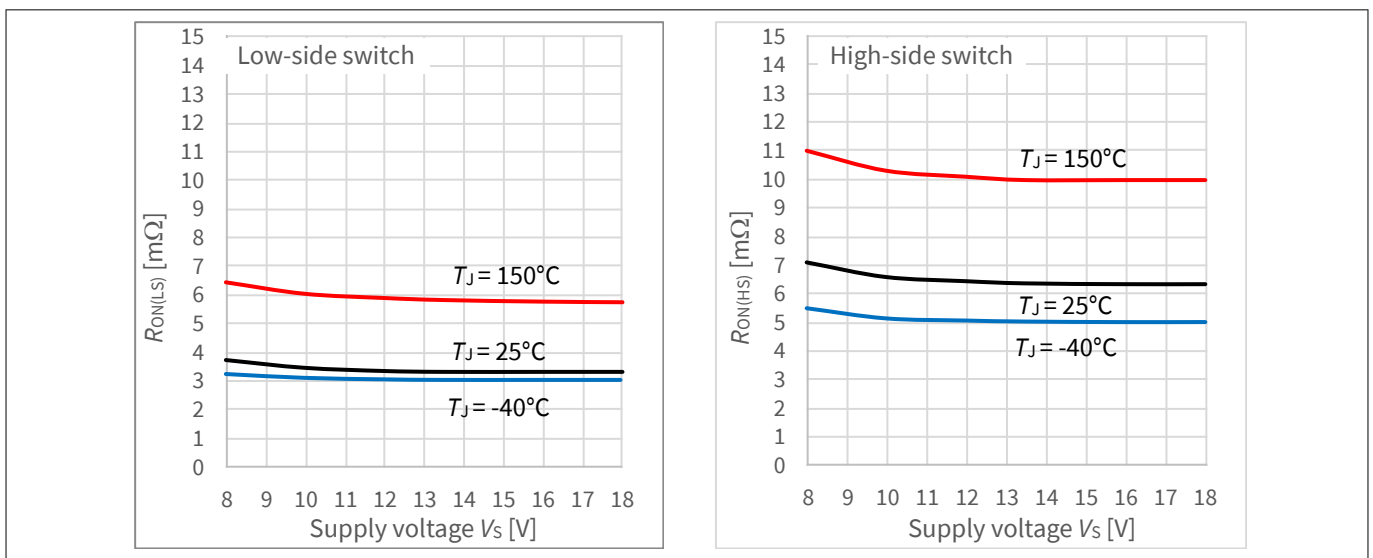

**Figure 6** Typical quiescent current  $I_{VS(OFF)}$  characteristics

**4.2 Power stages**

The power stages of the BTN9970LV consist of a p-channel vertical DMOS transistor for the high-side switch and a n-channel vertical DMOS transistor for the low-side switch. All protection and diagnostic functions are located in a separate driver IC. Both switches allow active freewheeling and thus minimizing power dissipation during PWM control.

The ON-state resistance  $R_{ON}$  is dependent on the supply voltage  $V_S$  as well as on the junction temperature  $T_j$ . The typical ON-state resistance characteristics are shown in Figure 7.



**Figure 7** Typical ON-state resistance vs. supply voltage  $V_S$

**4 Block description and characteristics**

**Table 6 Power stages – static characteristics**

$V_S = 8\text{ V to }18\text{ V}$ ,  $T_j = -40^\circ\text{C to }150^\circ\text{C}$ , all voltages with respect to ground, positive current flowing into pin (unless otherwise specified)

Parameter	Symbol	Values			Unit	Note or condition
		Min.	Typ.	Max.		
<b>High-side switch – static characteristics</b>						
ON-state high-side resistance	$R_{ON(HS)}$	–	6.3	–	mΩ	$I_{OUT} = 15\text{ A}$ ; $V_S = 13.5\text{ V}$ $T_j = 25^\circ\text{C}$ <sup>9)</sup>
ON-state high-side resistance	$R_{ON(HS)}$	–	9.0	11.8	mΩ	$I_{OUT} = 15\text{ A}$ ; $V_S = 13.5\text{ V}$ $T_j = 150^\circ\text{C}$
ON-state high-side resistance	$R_{ON(HS)}$	–	9.5	–	mΩ	$I_{OUT} = 15\text{ A}$ ; $V_S = 6\text{ V}$ $T_j = 25^\circ\text{C}$ <sup>9)</sup>
ON-state high-side resistance	$R_{ON(HS)}$	–	13.5	16.7	mΩ	$I_{OUT} = 15\text{ A}$ ; $V_S = 6\text{ V}$ $T_j = 150^\circ\text{C}$
Leakage current high-side	$I_{L(LKHS)}$	–	–	1	μA	$V_{INH} = V_{IN} = 0\text{ V}$ ; $V_{OUT} = 0\text{ V}$ $T_j \leq 85^\circ\text{C}$ <sup>9)</sup>
Leakage current high-side	$I_{L(LKHS)}$	–	–	60	μA	$V_{INH} = V_{IN} = 0\text{ V}$ ; $V_{OUT} = 0\text{ V}$ $T_j = 150^\circ\text{C}$
Reverse diode forward-voltage high-side	$V_{DS(HS)}$	–	0.9	–	V	$I_{OUT} = -15\text{ A}$ $T_j = -40^\circ\text{C}$ <sup>9) 10)</sup>
Reverse diode forward-voltage high-side	$V_{DS(HS)}$	–	0.85	–	V	$I_{OUT} = -15\text{ A}$ $T_j = 25^\circ\text{C}$ <sup>9) 10)</sup>
Reverse diode forward-voltage high-side	$V_{DS(HS)}$	–	0.7	0.9	V	$I_{OUT} = -15\text{ A}$ $T_j = 150^\circ\text{C}$ <sup>10)</sup>
<b>Low-side switch – static characteristics</b>						
ON-state low-side resistance	$R_{ON(LS)}$	–	3.4	–	mΩ	$I_{OUT} = -15\text{ A}$ ; $V_S = 13.5\text{ V}$ $T_j = 25^\circ\text{C}$ <sup>9)</sup>
ON-state low-side resistance	$R_{ON(LS)}$	–	5.7	6.3	mΩ	$I_{OUT} = -15\text{ A}$ ; $V_S = 13.5\text{ V}$ $T_j = 150^\circ\text{C}$
ON-state low-side resistance	$R_{ON(LS)}$	–	5.1	–	mΩ	$I_{OUT} = -15\text{ A}$ ; $V_S = 6\text{ V}$ $T_j = 25^\circ\text{C}$ <sup>9)</sup>
ON-state low-side resistance	$R_{ON(LS)}$	–	8.6	10.2	mΩ	$I_{OUT} = -15\text{ A}$ ; $V_S = 6\text{ V}$ $T_j = 150^\circ\text{C}$
Leakage current low-side	$I_{L(LKLS)}$	–	–	1	μA	$V_{INH} = V_{IN} = 0\text{ V}$ ; $V_{OUT} = V_S$ $T_j \leq 85^\circ\text{C}$ <sup>9)</sup>

**(table continues...)**

<sup>9)</sup> Not subject to production test, specified by design.

<sup>10)</sup> Due to active freewheeling, diode is conducting only for a few μs, depending on the selected slew rate SRx.

**4 Block description and characteristics**

**Table 6 (continued) Power stages – static characteristics**

$V_S = 8\text{ V to }18\text{ V}$ ,  $T_j = -40^\circ\text{C to }150^\circ\text{C}$ , all voltages with respect to ground, positive current flowing into pin (unless otherwise specified)

Parameter	Symbol	Values			Unit	Note or condition
		Min.	Typ.	Max.		
Leakage current low-side	$I_{L(LKLS)}$	–	–	30	$\mu\text{A}$	$V_{INH} = V_{IN} = 0\text{ V}$ ; $V_{OUT} = V_S$ $T_j = 150^\circ\text{C}$
Reverse diode forward-voltage low-side	$-V_{DS(LS)}$	–	0.9	–	V	$I_{OUT} = 15\text{ A}$ $T_j = -40^\circ\text{C}$ <sup>9) 10)</sup>
Reverse diode forward-voltage low-side	$-V_{DS(LS)}$	–	0.8	–	V	$I_{OUT} = 15\text{ A}$ $T_j = 25^\circ\text{C}$ <sup>9) 10)</sup>
Reverse diode forward-voltage low-side	$-V_{DS(LS)}$	–	0.6	0.8	V	$I_{OUT} = 15\text{ A}$ $T_j = 150^\circ\text{C}$ <sup>10)</sup>

**Table 7 Power stages – dynamic characteristics**

Paragraph condition:  $V_S = 13.5\text{ V}$ ,  $T_j = -40^\circ\text{C to }150^\circ\text{C}$ ,  $R_{load} = 2\ \Omega$ ,  $30\ \mu\text{H} < L_{load} < 40\ \mu\text{H}$  (in series to  $R_{load}$ ), single pulse,  $I_{OUT} > 90\text{ mA}$  freewheeling, all voltages with respect to ground, positive current flowing into pin (unless otherwise specified)

Parameter	Symbol	Values			Unit	Note or condition
		Min.	Typ.	Max.		

**High-side switch – dynamic characteristics**

Rise-time of HS for SR0	$t_{r(HS),SR0}$	0.05	0.25	0.55	$\mu\text{s}$	SR-level = SR0
Rise-time of HS for SR1	$t_{r(HS),SR1}$	–	0.36	–	$\mu\text{s}$	SR-level = SR1
Rise-time of HS for SR2	$t_{r(HS),SR2}$	–	0.5	–	$\mu\text{s}$	SR-level = SR2
Rise-time of HS for SR3	$t_{r(HS),SR3}$	–	0.83	–	$\mu\text{s}$	SR-level = SR3
Rise-time of HS for SR4	$t_{r(HS),SR4}$	–	1.0	–	$\mu\text{s}$	SR-level = SR4
Rise-time of HS for SR5	$t_{r(HS),SR5}$	0.22	1.25	5.00	$\mu\text{s}$	SR-level = SR5
Rise-time of HS for SR6	$t_{r(HS),SR6}$	–	2.5	–	$\mu\text{s}$	SR-level = SR6
Rise-time of HS for SR7	$t_{r(HS),SR7}$	–	5.0	–	$\mu\text{s}$	SR-level = SR7
Switch-ON delay time HS for SR0	$t_{dr(HS),SR0}$	2.4	3.6	4.4	$\mu\text{s}$	SR-level = SR0
Switch-ON delay time HS for SR1	$t_{dr(HS),SR1}$	–	4.1	–	$\mu\text{s}$	SR-level = SR1
Switch-ON delay time HS for SR2	$t_{dr(HS),SR2}$	–	4.6	–	$\mu\text{s}$	SR-level = SR2

**(table continues...)**

<sup>9</sup> Not subject to production test, specified by design.

<sup>10</sup> Due to active freewheeling, diode is conducting only for a few  $\mu\text{s}$ , depending on the selected slew rate SRx.

**4 Block description and characteristics**

**Table 7 (continued) Power stages – dynamic characteristics**

Paragraph condition:  $V_S = 13.5\text{ V}$ ,  $T_j = -40^\circ\text{C}$  to  $150^\circ\text{C}$ ,  $R_{load} = 2\ \Omega$ ,  $30\ \mu\text{H} < L_{load} < 40\ \mu\text{H}$  (in series to  $R_{load}$ ), single pulse,  $I_{OUT} > 90\text{ mA}$  freewheeling, all voltages with respect to ground, positive current flowing into pin (unless otherwise specified)

Parameter	Symbol	Values			Unit	Note or condition
		Min.	Typ.	Max.		
Switch-ON delay time HS for SR3	$t_{dr(HS),SR3}$	–	5.9	–	$\mu\text{s}$	SR-level = SR3
Switch-ON delay time HS for SR4	$t_{dr(HS),SR4}$	–	6.8	–	$\mu\text{s}$	SR-level = SR4
Switch-ON delay time HS for SR5	$t_{dr(HS),SR5}$	4.6	8	11.2	$\mu\text{s}$	SR-level = SR5
Switch-ON delay time HS for SR6	$t_{dr(HS),SR6}$	–	13.2	–	$\mu\text{s}$	SR-level = SR6
Switch-ON delay time HS for SR7	$t_{dr(HS),SR7}$	–	23.3	–	$\mu\text{s}$	SR-level = SR7
Fall-time of HS for SR0	$t_{f(HS),SR0}$	0.05	0.25	0.55	$\mu\text{s}$	SR-level = SR0
Fall-time of HS for SR1	$t_{f(HS),SR1}$	–	0.36	–	$\mu\text{s}$	SR-level = SR1
Fall-time of HS for SR2	$t_{f(HS),SR2}$	–	0.5	–	$\mu\text{s}$	SR-level = SR2
Fall-time of HS for SR3	$t_{f(HS),SR3}$	–	0.83	–	$\mu\text{s}$	SR-level = SR3
Fall-time of HS for SR4	$t_{f(HS),SR4}$	–	1.0	–	$\mu\text{s}$	SR-level = SR4
Fall-time of HS for SR5	$t_{f(HS),SR5}$	0.22	1.25	5.00	$\mu\text{s}$	SR-level = SR5
Fall-time of HS for SR6	$t_{f(HS),SR6}$	–	2.5	–	$\mu\text{s}$	SR-level = SR6
Fall-time of HS for SR7	$t_{f(HS),SR7}$	–	5.0	–	$\mu\text{s}$	SR-level = SR7
Switch-OFF delay time HS for SR0	$t_{df(HS),SR0}$	1.8	2.5	4.2	$\mu\text{s}$	SR-level = SR0
Switch-OFF delay time HS for SR1	$t_{df(HS),SR1}$	–	2.8	–	$\mu\text{s}$	SR-level = SR1
Switch-OFF delay time HS for SR2	$t_{df(HS),SR2}$	–	3.1	–	$\mu\text{s}$	SR-level = SR2
Switch-OFF delay time HS for SR3	$t_{df(HS),SR3}$	–	3.9	–	$\mu\text{s}$	SR-level = SR3
Switch-OFF delay time HS for SR4	$t_{df(HS),SR4}$	–	4.4	–	$\mu\text{s}$	SR-level = SR4
Switch-OFF delay time HS for SR5	$t_{df(HS),SR5}$	3.4	5.0	9.0	$\mu\text{s}$	SR-level = SR5
Switch-OFF delay time HS for SR6	$t_{df(HS),SR6}$	–	8.1	–	$\mu\text{s}$	SR-level = SR6
Switch-OFF delay time HS for SR7	$t_{df(HS),SR7}$	–	14.0	–	$\mu\text{s}$	SR-level = SR7

**(table continues...)**

**4 Block description and characteristics**

**Table 7 (continued) Power stages – dynamic characteristics**

Paragraph condition:  $V_S = 13.5\text{ V}$ ,  $T_j = -40^\circ\text{C}$  to  $150^\circ\text{C}$ ,  $R_{load} = 2\ \Omega$ ,  $30\ \mu\text{H} < L_{load} < 40\ \mu\text{H}$  (in series to  $R_{load}$ ), single pulse,  $I_{OUT} > 90\text{ mA}$  freewheeling, all voltages with respect to ground, positive current flowing into pin (unless otherwise specified)

Parameter	Symbol	Values			Unit	Note or condition
		Min.	Typ.	Max.		
<b>Low-side switch – dynamic characteristics</b>						
Rise-time of LS for SR0	$t_{r(LS),SR0}$	0.05	0.25	0.55	$\mu\text{s}$	SR-level = SR0
Rise-time of LS for SR1	$t_{r(LS),SR1}$	–	0.36	–	$\mu\text{s}$	SR-level = SR1
Rise-time of LS for SR2	$t_{r(LS),SR2}$	–	0.5	–	$\mu\text{s}$	SR-level = SR2
Rise-time of LS for SR3	$t_{r(LS),SR3}$	–	0.83	–	$\mu\text{s}$	SR-level = SR3
Rise-time of LS for SR4	$t_{r(LS),SR4}$	–	1.0	–	$\mu\text{s}$	SR-level = SR4
Rise-time of LS for SR5	$t_{r(LS),SR5}$	0.22	1.25	5.00	$\mu\text{s}$	SR-level = SR5
Rise-time of LS for SR6	$t_{r(LS),SR6}$	–	2.5	–	$\mu\text{s}$	SR-level = SR6
Rise-time of LS for SR7	$t_{r(LS),SR7}$	–	5.0	–	$\mu\text{s}$	SR-level = SR7
Switch-ON delay time LS for SR0	$t_{df(LS),SR0}$	2.6	3.6	5.4	$\mu\text{s}$	SR-level = SR0
Switch-ON delay time LS for SR1	$t_{df(LS),SR1}$	–	4.1	–	$\mu\text{s}$	SR-level = SR1
Switch-ON delay time LS for SR2	$t_{df(LS),SR2}$	–	4.6	–	$\mu\text{s}$	SR-level = SR2
Switch-ON delay time LS for SR3	$t_{df(LS),SR3}$	–	5.9	–	$\mu\text{s}$	SR-level = SR3
Switch-ON delay time LS for SR4	$t_{df(LS),SR4}$	–	6.8	–	$\mu\text{s}$	SR-level = SR4
Switch-ON delay time LS for SR5	$t_{df(LS),SR5}$	6.4	8.0	12.7	$\mu\text{s}$	SR-level = SR5
Switch-ON delay time LS for SR6	$t_{df(LS),SR6}$	–	13.2	–	$\mu\text{s}$	SR-level = SR6
Switch-ON delay time LS for SR7	$t_{df(LS),SR7}$	–	23.3	–	$\mu\text{s}$	SR-level = SR7
Fall-time of LS for SR0	$t_{f(LS),SR0}$	0.05	0.25	0.55	$\mu\text{s}$	SR-level = SR0
Fall-time of LS for SR1	$t_{f(LS),SR1}$	–	0.36	–	$\mu\text{s}$	SR-level = SR1
Fall-time of LS for SR2	$t_{f(LS),SR2}$	–	0.5	–	$\mu\text{s}$	SR-level = SR2
Fall-time of LS for SR3	$t_{f(LS),SR3}$	–	0.83	–	$\mu\text{s}$	SR-level = SR3
Fall-time of LS for SR4	$t_{f(LS),SR4}$	–	1.0	–	$\mu\text{s}$	SR-level = SR4
Fall-time of LS for SR5	$t_{f(LS),SR5}$	0.22	1.25	5.00	$\mu\text{s}$	SR-level = SR5
Fall-time of LS for SR6	$t_{f(LS),SR6}$	–	2.5	–	$\mu\text{s}$	SR-level = SR6
Fall-time of LS for SR7	$t_{f(LS),SR7}$	–	5.0	–	$\mu\text{s}$	SR-level = SR7

**(table continues...)**

**4 Block description and characteristics**

**Table 7 (continued) Power stages – dynamic characteristics**

Paragraph condition:  $V_S = 13.5\text{ V}$ ,  $T_j = -40^\circ\text{C}$  to  $150^\circ\text{C}$ ,  $R_{load} = 2\ \Omega$ ,  $30\ \mu\text{H} < L_{load} < 40\ \mu\text{H}$  (in series to  $R_{load}$ ), single pulse,  $I_{OUT} > 90\text{ mA}$  freewheeling, all voltages with respect to ground, positive current flowing into pin (unless otherwise specified)

Parameter	Symbol	Values			Unit	Note or condition
		Min.	Typ.	Max.		
Switch-OFF delay time LS for SR0	$t_{dr(LS),SR0}$	1.5	2.5	3.1	$\mu\text{s}$	SR-level = SR0
Switch-OFF delay time LS for SR1	$t_{dr(LS),SR1}$	–	2.8	–	$\mu\text{s}$	SR-level = SR1
Switch-OFF delay time LS for SR2	$t_{dr(LS),SR2}$	–	3.1	–	$\mu\text{s}$	SR-level = SR2
Switch-OFF delay time LS for SR3	$t_{dr(LS),SR3}$	–	3.9	–	$\mu\text{s}$	SR-level = SR3
Switch-OFF delay time LS for SR4	$t_{dr(LS),SR4}$	–	4.4	–	$\mu\text{s}$	SR-level = SR4
Switch-OFF delay time LS for SR5	$t_{dr(LS),SR5}$	2.8	5.0	6.4	$\mu\text{s}$	SR-level = SR5
Switch-OFF delay time LS for SR6	$t_{dr(LS),SR6}$	–	8.1	–	$\mu\text{s}$	SR-level = SR6
Switch-OFF delay time LS for SR7	$t_{dr(LS),SR7}$	–	14.0	–	$\mu\text{s}$	SR-level = SR7

**4.2.1 Switching times**

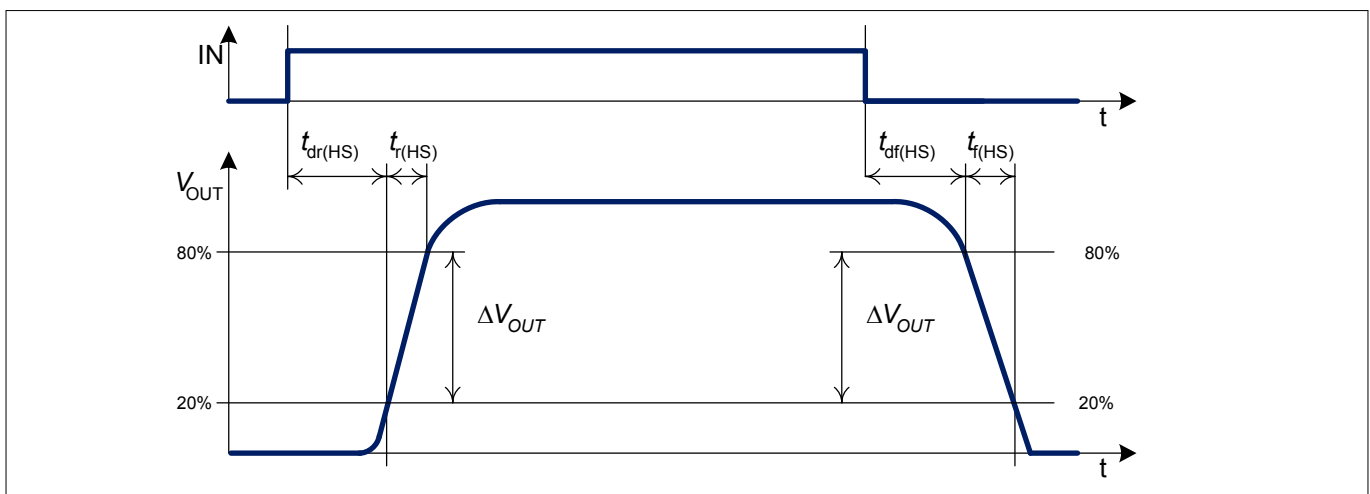

**Figure 8 Definition of switching times high-side ( $R_{load}$  to GND)**



**4 Block description and characteristics**

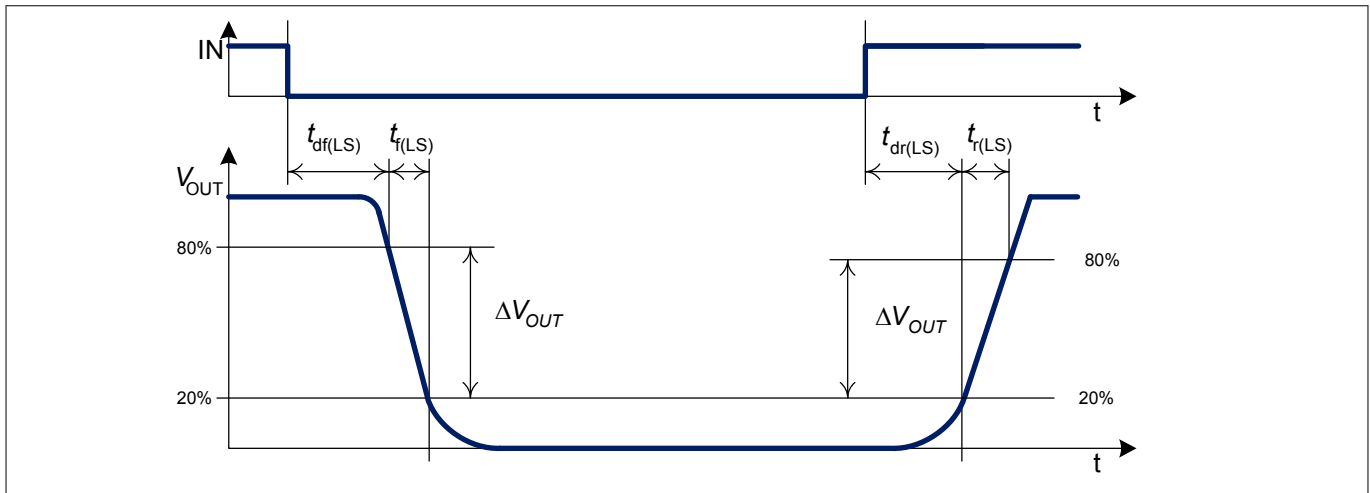

**Figure 9 Definition of switching times low-side ( $R_{load}$  to  $V_S$ )**

Due to the timing differences for the rising and the falling edge there will be a slight difference between the length of the input pulse and the length of the output pulse. It can be calculated using the following formulas for  $\Delta t_{XS} = t_{IN} - t_{OUT}$ :

- $\Delta t_{HS} = (t_{dr(HS)} + 0.5 t_{r(HS)}) - (t_{df(HS)} + 0.5 t_{f(HS)})$
- $\Delta t_{LS} = (t_{df(LS)} + 0.5 t_{f(LS)}) - (t_{dr(LS)} + 0.5 t_{r(LS)})$

One of 8 different slew rates (SR) can be selected as described in [Chapter 4.4.2](#).

After waking up from stand-by mode, the slew rate level SR0 is selected.

**4.3 Protection functions**

The device provides integrated protection functions. These are designed to prevent IC destruction under fault conditions described in the datasheet. Fault conditions are considered as “outside” normal operating range.

Protection functions are not designed to be used for continuous or repetitive operation, with the exception of the overcurrent protection ([Chapter 4.3.3](#)) and undervoltage shutdown ([Chapter 4.3.1](#)).

Undervoltage, overtemperature and overcurrent events are indicated by a fault current  $I_{IS(fault)}$  at the IS pin as described in [Chapter 4.4.3](#).

The protection functions of the BTN9970LV are prioritized in the following way:

**Table 8 Protection functions priorities**

Priority	Function	Reference
0 (highest)	Undervoltage shutdown	<a href="#">Chapter 4.3.1</a>
1	Overtemperature protection	<a href="#">Chapter 4.3.2</a>
2	Overcurrent protection	<a href="#">Chapter 4.3.3</a>
3	Stand-by mode	The device only goes into stand-by mode if no fault is present

**Table 9 Electrical characteristics – protection functions**

$V_S = 8\text{ V to }18\text{ V}$ ,  $T_j = -40^\circ\text{C to }150^\circ\text{C}$ , all voltages with respect to ground, positive current flowing into pin (unless otherwise specified)

Parameter	Symbol	Values			Unit	Note or condition
		Min.	Typ.	Max.		

**Undervoltage shutdown**

(table continues...)

**4 Block description and characteristics**

**Table 9 (continued) Electrical characteristics – protection functions**

$V_S = 8\text{ V to }18\text{ V}$ ,  $T_j = -40^\circ\text{C to }150^\circ\text{C}$ , all voltages with respect to ground, positive current flowing into pin (unless otherwise specified)

Parameter	Symbol	Values			Unit	Note or condition
		Min.	Typ.	Max.		
Switch-ON voltage	$V_{UV(ON)}$	–	–	5.5	V	$V_S$ increasing
Switch-OFF voltage	$V_{UV(OFF)}$	3.8	–	4.5	V	$V_S$ decreasing
ON/OFF hysteresis	$V_{UV(HY)}$	–	0.8	–	V	<sup>11)</sup>
<b>Overcurrent shutdown</b>						
Overcurrent detection level high-side	$I_{OCH0}$	60	80	98	A	$V_S = 13.5\text{ V}$
Overcurrent detection level low-side	$I_{OCL0}$	60	80	98	A	$V_S = 13.5\text{ V}$
<b>Thermal shutdown</b>						
Thermal shutdown junction temperature	$T_{jSD}$	155	175	200	°C	<sup>11)</sup>
Thermal switch-ON junction temperature	$T_{jSO}$	150	–	190	°C	<sup>11)</sup>
Thermal hysteresis	$\Delta T$	–	7	–	K	<sup>11)</sup>
<b>Protection and reset timing</b>						
Shut-OFF time for HS and LS	$t_{CLS}$	–	115	210	µs	
Undervoltage recovery delay time	$t_{UVD}$	–	115	210	µs	
Reset pulse at INH and IN pin (INH & IN low)	$t_{reset}$	9	–	–	µs	–

**4.3.1 Undervoltage shutdown with restart**

To avoid uncontrolled motion of the driven motor at low voltages the device switches off (output is tri-state), if the supply voltage drops below the switch-OFF voltage  $V_{UV(OFF)}$ .

If a slew rate level SR0 to SR4 is selected, the NovalithIC™+ will switch off with the selected slew rate in case of an undervoltage detection. For slew rate level SR5 to SR7, the device will switch off with slew rate level SR4 instead.

As soon as the supply voltage  $V_S$  rises above the switch-ON voltage  $V_{UV(ON)}$ , with a hysteresis of  $V_{UV(HY)}$ , the output channel of the device follows the IN pin again.

The restart is delayed with a time  $t_{UVD}$  which protects the device in case the undervoltage condition is caused by a short circuit event (according to AEC-Q100-012).

After power-up, the device is starting without waiting for the delay time  $t_{UVD}$ .

The slew rate level and the undervoltage event are stored in analog latches, which are supplied by the INH or/and IN pin. Thus at least one of the two pins always shall be set high during this undervoltage event, until the presence of the  $I_{IS(fault)}$  current, to keep the previously set slew rate level after the undervoltage shutdown.

<sup>11)</sup> Not subject to production test, specified by design.

**4 Block description and characteristics**

In the case of both INH and IN being 0 during an undervoltage event, a power on reset is performed.

In case of an undervoltage event, the fault current  $I_{IS(fault)}$  is provided at the IS pin, once the supply voltage rises above  $V_{UV(ON)}$  again.

The fault signal at the IS pin is reset after  $t_{UVd}$  after the supply voltage rises above  $V_{UV(ON)}$ . This behavior is shown in [Figure 10](#).

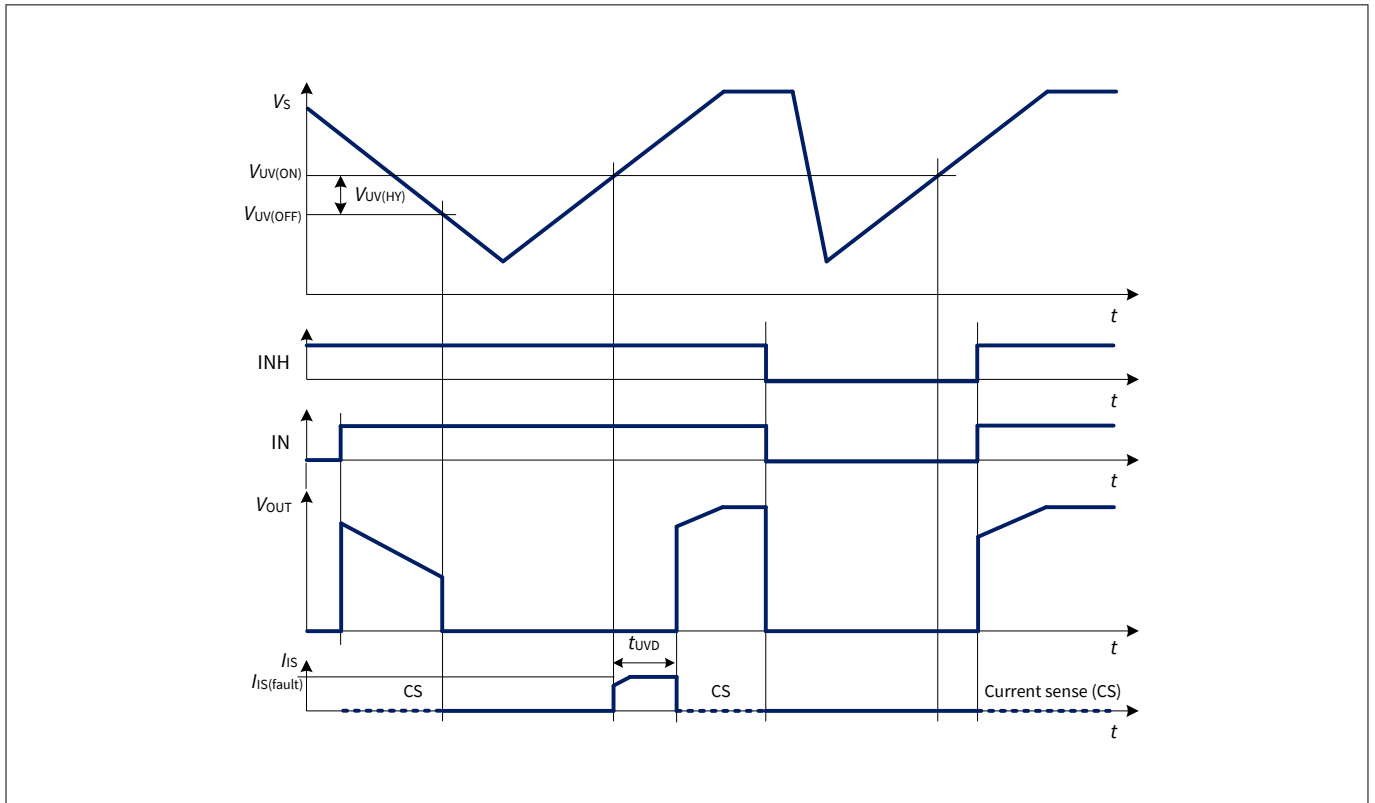

**Figure 10** Timing diagram for undervoltage behavior for load to GND

**4.3.2 Overtemperature protection**

The NovalithIC™+ is protected against overtemperature by an integrated temperature sensor. Overtemperature leads to a shutdown of the output stage (both the high-side and low-side switch).

This state is latched until the device is reset by a low signal with a minimum length of  $t_{reset}$  at the INH and IN pin, provided that its temperature has decreased at least the thermal hysteresis  $\Delta T$  in the meantime.

If a slew rate level SR0 to SR4 is selected, the NovalithIC™+ will switch off with the selected slew rate in case of overtemperature. For slew rate level SR5 to SR7, the device will switch off with slew rate level SR4 instead.

**4.3.3 Overcurrent protection**

The current in the bridge is measured in both switches.

As soon as the current in forward direction in one switch (high-side or low-side) is reaching the limit  $I_{OCx}$ , the device goes either into current limitation mode or switches off with latch, depending on the selected SR-level. The corresponding dependencies are described in [Table 10](#).

**Table 10** Slew rate dependent overcurrent strategies

SR-level	Mode	Note
SR0	Current limitation (retry)	For details see <a href="#">Chapter 4.3.3.1</a>
SR1		

(table continues...)

**4 Block description and characteristics**

**Table 10 (continued) Slew rate dependent overcurrent strategies**

SR-level	Mode	Note
SR2		
SR3		
SR4		
SR5		
SR6	Switch-OFF with latch	Requiring reset of the fault latch For details see <a href="#">Chapter 4.3.3.2</a>
SR7		

**4.3.3.1 Current limitation**

If this mode is selected according to [Table 10](#) and the current in forward direction in one switch (high-side or low-side) has reached the limit  $I_{OCx}$ , the affected switch is deactivated and the other switch is activated for  $t_{CLS}$ . During that time all changes at the IN pin are ignored.

However, during current limitation, the INH pin can still be used to switch both MOSFETs off.

After  $t_{CLS}$  the switches follow the IN pin again.

The fault signal at the IS pin is reset after  $1.5 \cdot t_{CLS}$ . This behavior is shown in [Figure 11](#).

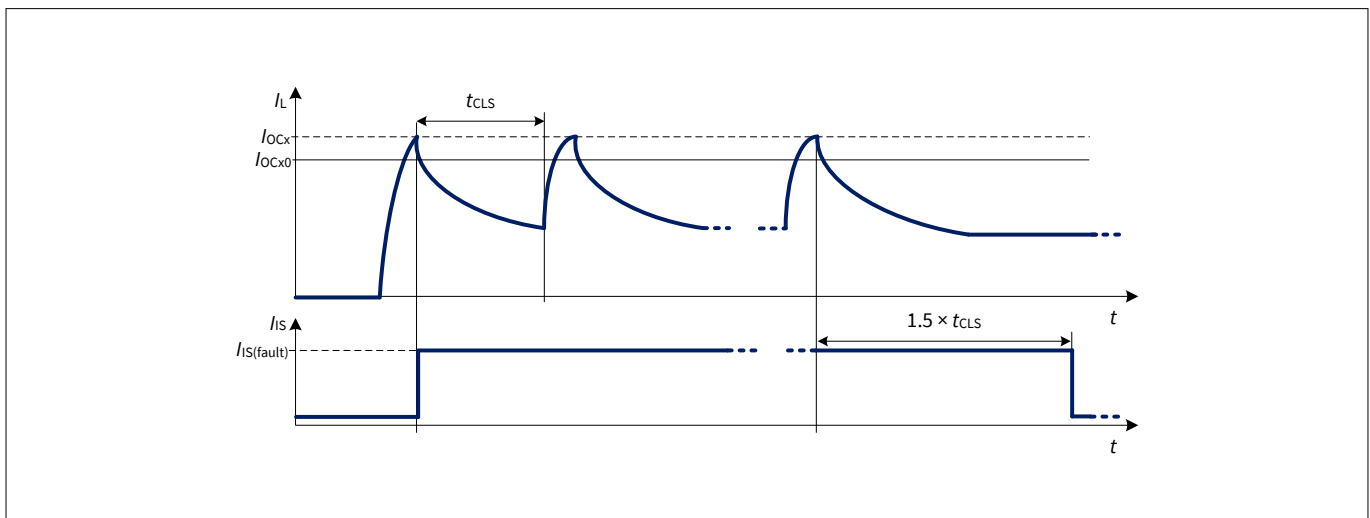

**Figure 11 Timing diagram current limitation (inductive load)**

For this mode, the MOSFETs are switched off each with the same slew rates (SR-level) as in normal operation. In combination with a typical inductive load, such as a motor, this results in a switched mode current limitation. This method of limiting the current has the advantage of greatly reduced power dissipation in the BTN9970LV compared to driving the MOSFET in linear mode.

Therefore it is possible to use the current limitation for a short time without exceeding the maximum allowed junction temperature (e.g. for limiting the inrush current during motor start up). However, the regular use of the current limitation is allowed as long as the specified maximum junction temperature is not exceeded. Exceeding this temperature can reduce the lifetime of the device.

**4.3.3.2 Switch-OFF with latch**

If this mode is selected according to [Table 10](#) and as soon as the current in forward direction in one switch (high-side or low-side) has reached the limit  $I_{OCx}$ , both output stages are shut down. This state is latched until the device is reset by a low signal with a minimum length of  $t_{reset}$  at the INH and IN pin. This behavior is illustrated in [Figure 12](#).

**4 Block description and characteristics**

In order to minimize power dissipation, the MOSFETs are switched off each with the same slew rate level SR4.

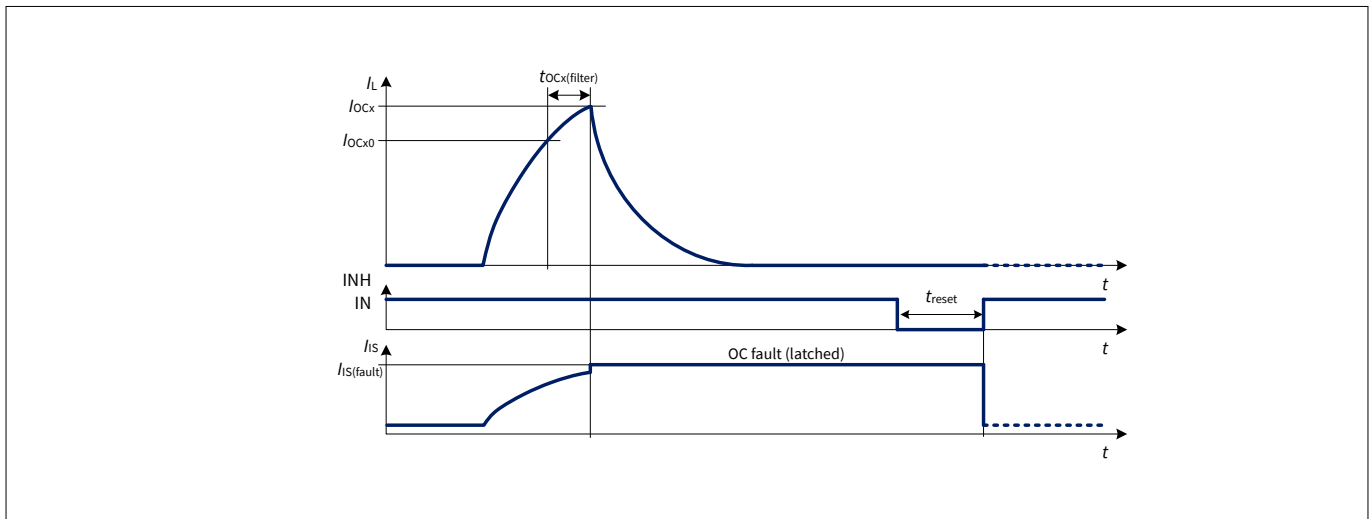

**Figure 12** Timing diagram switch-OFF with latch (inductive load)

**4.3.4 Short circuit protection**

The device provides embedded protection functions against

- Output short circuit to ground
- Output short circuit to supply voltage
- Short circuit of load

The short circuit protection is realized by the previously described undervoltage and overcurrent protection in combination with the overtemperature shutdown of the device.

**4.4 Control and diagnostics**

The control inputs IN and INH consist of TTL/CMOS compatible Schmitt triggers with hysteresis which control the integrated gate drivers for the MOSFETs. Setting the INH or/and IN pin to high enables the device. When the INH pin is high, one of the two power switches is switched on depending on the status of the IN pin. To deactivate both switches, the INH pin has to be set to low. No external driver is needed. The BTN9970LV can be interfaced directly to a microcontroller, as long as the maximum ratings in [Chapter 3.1](#) are not exceeded.

**Table 11** Electrical characteristics – control and diagnostics

$V_S = 8\text{ V to }18\text{ V}$ ,  $T_j = -40^\circ\text{C to }150^\circ\text{C}$ , all voltages with respect to ground, positive current flowing into pin (unless otherwise specified)

Parameter	Symbol	Values			Unit	Note or condition
		Min.	Typ.	Max.		
<b>Control inputs (IN and INH)</b>						
High level voltage INH, IN	$V_{INH(H)}$ $V_{IN(H)}$	–	1.6	2.1	V	–
Low level voltage INH, IN	$V_{INH(L)}$ $V_{IN(L)}$	1.0	1.3	–	V	–
Low level voltage INH, IN for $V_S < 8\text{ V}$	$V_{INH(L)\_UV(OFF)}$ $V_{IN(L)\_UV(OFF)}$	0.4	–	–	V	$V_S = 4.5\text{ V}$ , falling $V_S$

(table continues...)

**4 Block description and characteristics**

**Table 11 (continued) Electrical characteristics – control and diagnostics**

$V_S = 8\text{ V to }18\text{ V}$ ,  $T_j = -40^\circ\text{C to }150^\circ\text{C}$ , all voltages with respect to ground, positive current flowing into pin (unless otherwise specified)

Parameter	Symbol	Values			Unit	Note or condition
		Min.	Typ.	Max.		
Input voltage hysteresis	$V_{INH(HYS)}$ $V_{IN(HYS)}$	–	300	–	mV	<sup>12)</sup>
Input current high level	$I_{INH(H)}$ $I_{IN(H)}$	25	50	80	μA	$V_{IN} = V_{INH} = 5.5\text{ V}$
Input current low level	$I_{INH(L)}$ $I_{IN(L)}$	3	6	10	μA	$V_{IN} = V_{INH} = 1.0\text{ V}$

**Slew rate selection**

Slew rate level selection pulse time	$t_{SR}$	0.5	–	80	μs	See Figure 13
Slew rate selection mode settling time	$t_{SRM}$	1	–	–	μs	See Figure 13
Wake-up time	$t_{wake-up}$	–	–	5	μs	After stand-by <sup>12)</sup>
Lag time between IN/INH state change	$t_{lag}$	0.5	–	–	μs	<sup>12)</sup>
Time to enter stand-by mode	$t_{stdby}$	100	–	300	μs	After both INH and IN transitioned from high to low
Sense current for SR-level SR0	$I_{IS(SR0)}$	1.8	2.15	2.5	mA	SR-level = SR0
Current sense step between two SR-levels	$I_{IS(SR\_step)}$	200	240	290	μA	–

**Current sense**

Differential current sense ratio in static on-condition $dk_{ILIS} = dIL/dIIS$ BTN9970	$dk_{ILIS}$	32.8	40	47.2	$10^3$	$1\text{ A} \leq I_L < I_{OCH0}$ $V_S = 13.5\text{ V}$ $R_{IS} = 2\text{ k}\Omega$
Sense current in fault condition	$I_{IS(fault)}$	2.51	2.75	3.25	mA	$V_S = 13.5\text{ V}$
Maximum analog sense current in normal operational condition	$I_{IS(CS)}$	–	–	2.5	mA	$V_S = 13.5\text{ V}$ ; in CS mode <sup>12)</sup>
Isense leakage current	$I_{ISL}$	–	–	1	μA	$V_{INH} = V_{IN} = 0\text{ V}$ $R_{IS} = 2\text{ k}\Omega$
Isense offset current	$I_{IS(offset)}$	30	160	385	μA	$V_{INH} = 5\text{ V}$ $V_{IN} = 0\text{ V}$ or $I_{SD(HS)} = 0\text{ A}$ $R_{IS} = 2\text{ k}\Omega$

**(table continues...)**

<sup>12)</sup> Not subject to production test, specified by design.

**4 Block description and characteristics**

**Table 11 (continued) Electrical characteristics – control and diagnostics**

$V_S = 8\text{ V to }18\text{ V}$ ,  $T_j = -40^\circ\text{C to }150^\circ\text{C}$ , all voltages with respect to ground, positive current flowing into pin (unless otherwise specified)

Parameter	Symbol	Values			Unit	Note or condition
		Min.	Typ.	Max.		
Temperature sense at 25°C	$I_{IS(T)_{25^\circ\text{C}}}$	–	1.2	–	mA	$I_{IS(T)}$ $T_j = 25^\circ\text{C}$ $R_{IS} = 2\text{ k}\Omega$
Temperature coefficient for temperature sense	$k_{TIS}$	3.16	3.72	4.28	$\mu\text{A/K}$	<sup>12)</sup>

**4.4.1 Dead time generation**

In bridge applications it has to be assured that the high-side and low-side MOSFET are not conducting at the same time, connecting directly the battery voltage to GND. This is assured by a circuit in the driver IC, generating a so called dead time between switching off one MOSFET and switching on the other.

The dead time generated in the driver IC is dependent on the selected slew rate.

**4.4.2 Adjustable slew rate**

In order to optimize electromagnetic emission, one of 8 different switching speeds for the MOSFETs can be selected. This selectability allows the user to optimize the balance between emission and power dissipation within his own application. The slew rate adjustment function is only accessible, if no fault is present.

In case the device was in stand-by mode previously, the function is available after the device wake-up time  $t_{\text{wake-up}}$ . Therefore the first pulse at pin IN needs to exceed the wake-up time  $t_{\text{wake-up}}$ .

When INH = low and IN = high without a fault being present, the device is in SR selection mode with both high-side and low-side MOSFETs being switched off.

When the SR selection mode initially is entered, a temperature information is provided as described in [Chapter 4.4.3.2](#) at the IS pin independently from the selected SR-level.

Only when IN goes low (falling edge) for a duration of  $t_{\text{SR}}$ , the next mode is selected when IN rises again. During this transition pulse, the INH pin has to be low permanently.

In the next mode, the slew rate won't be changed, but a current sense signal  $I_{IS(\text{SRx})}$  depending on the currently selected SR-level SRx (as further described in [Chapter 4.4.3.2](#)) is provided at the IS pin. This allows to validate if the desired SR-level has been selected.

For any further transition pulse, the next SR-level will be selected. The newly selected SR-level then will be indicated at the IS pin with the corresponding  $I_{IS(\text{SRx})}$ .

After reaching SR-level SR7, the next selectable SR-level is SR0 again. This procedure is illustrated in [Figure 13](#).

The SR selection mode is left if a fault occurs or by setting INH to high. The procedure is shown in the state diagram in [Figure 16](#).

The states at pin IN and INH may not transition synchronous in the same direction, therefore a time delay of  $t_{\text{lag}}$  need to be applied.

After stand-by and power-up, the default value for the slew rate is level SR0.

After an undervoltage event the selected slew rate level is persistent, under the conditions described in [Chapter 4.3.1](#) with more details.

<sup>12)</sup> Not subject to production test, specified by design.

**4 Block description and characteristics**

In case an undervoltage event occurs during the slew rate selection mode, the slew rate configuration can not be guaranteed. Therefore slew rate programming need to be repeated once the undervoltage event has disappeared.

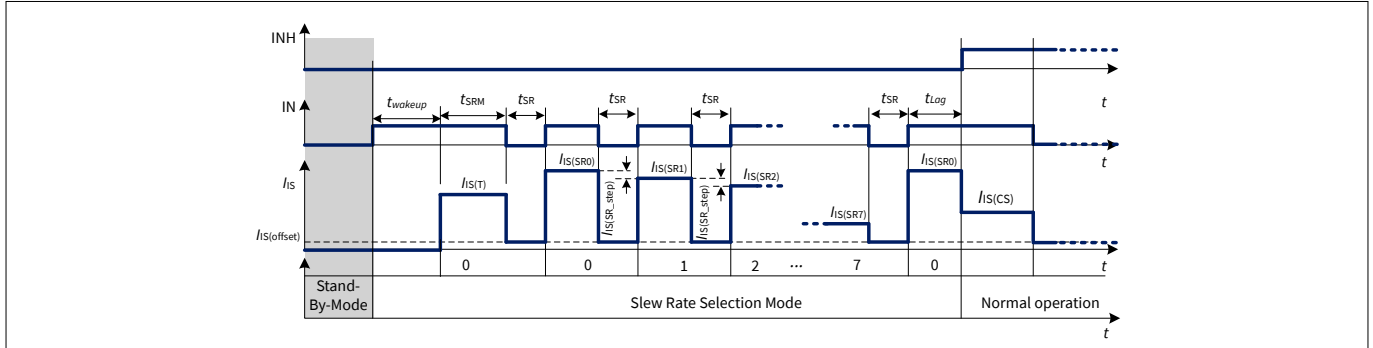

**Figure 13 Slew rate level selection**

Note:  $t_{wakeup}$  is only needed if the device was in stand-by-mode before.

**4.4.3 Status flag diagnosis with current and temperature sense capability**

The sense pin IS is used as a combined current sense, temperature sense, slew rate level feedback and fault flag output. Further details, in which state which signal is provided by the IS pin is described in Table 12. The IS pin has three different modes of operation:

**4.4.3.1 Current sense**

In normal operation (current sense mode), with the IN and INH pin being high (for further details see Table 12), a current source is connected to the IS pin, which delivers a current proportional to the forward load current flowing through the active high-side switch.

The sense current can be calculated out of the load current by the following equation.

$$I_{IS} = I_L / dk_{ILIS} + I_{IS(offset)}$$

The other way around, the load current can be calculated out of the sense current by following equation.

$$I_L = dk_{ILIS} \cdot (I_{IS} - I_{IS(offset)})$$

The differential current sense ratio  $dk_{ilis}$  is defined by.

$$dk_{ILIS} = (I_{L2} - I_{L1}) / (I_{IS}(I_{L2}) - I_{IS}(I_{L1}))$$

If the high-side drain current is zero ( $I_{SD(HS)} = 0$  A) the offset current  $I_{IS} = I_{IS(offset)}$  still will be driven. The external resistor  $R_{IS}$  determines the voltage per IS output current. The voltage can be calculated by  $V_{IS} = R_{IS} \cdot I_{IS}$ .



**4 Block description and characteristics**

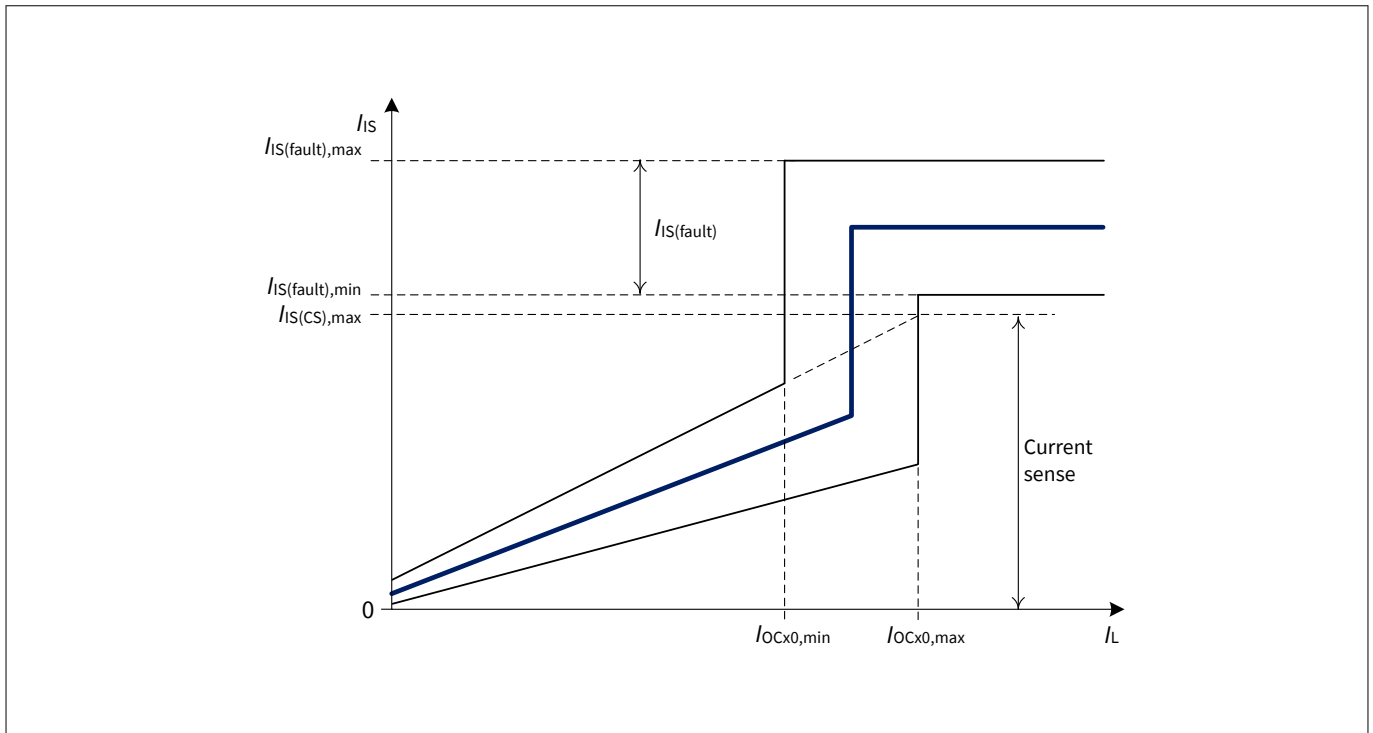

**Figure 14** Sense current vs. load current

**4.4.3.2 Temperature sense and slew rate feedback**

In slew rate selection mode, with the IN pin being high and the INH being low after the first transition (further details see [Chapter 4.4.2](#)) the IS pin provides a constant current  $I_{IS(SRx)}$ , allowing to distinguish between the different SR-levels.

The sense current  $I_{IS}$  can be calculated as follows for the slew rate level SRx:

$$I_{IS(SRx)} = I_{IS(SR0)} - x \cdot I_{IS(SR\_step)}$$

To correctly determine all eight slew rate levels,  $I_{IS(SR0)}$  and each individual device's  $I_{IS(SR\_step)}$  have to be calibrated.

When initially entering the SR selection mode, a current source is connected to the IS pin, which delivers a current proportional to the junction temperature of the control chip  $T_{CC}$ , which is illustrated in [Figure 15](#). The sense current  $I_{IS(T)}$  can be calculated out of the junction temperature in Kelvin T[K] by the following equation:

$$I_{IS(T)} = k_{TIS} \cdot T_{CC}$$

Based on the temperature coefficient  $k_{TIS}$ , the temperature  $T_{CC}$  then calculates as follows:

$$T_{CC} = I_{IS(T)} / k_{TIS}$$

**4 Block description and characteristics**

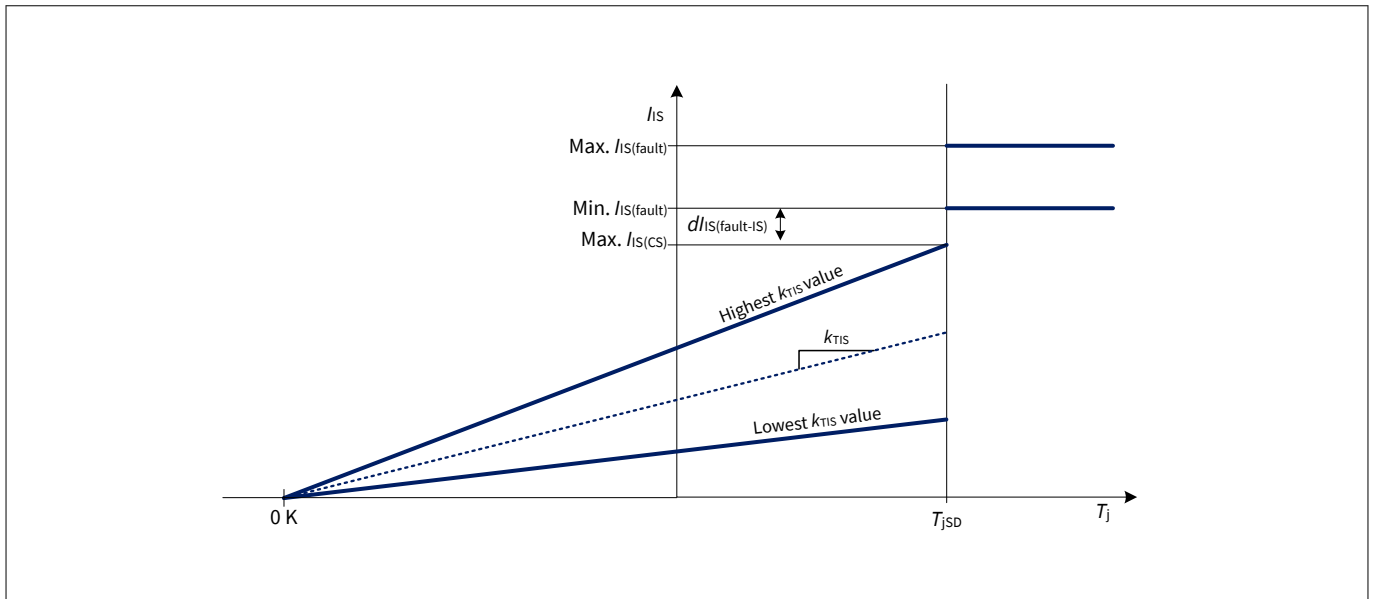

**Figure 15** Sense current vs. junction temperature in the initial state of the SR selection mode

**4.4.3.3 Fault feedback**

In case of a fault condition, according to the truth table (Table 12), the status output is connected to a current source which is independent of the load current and provides  $I_{IS(fault)}$ . The maximum voltage at the IS pin is determined by the choice of the external resistor and the supply voltage.

**4.4.4 Truth table**

**Table 12** Truth table

Device state	Inputs		Outputs			Mode
	INH	IN	HSS	LSS	IS	
Normal operation	0	0	OFF	OFF	$I_{IS(offset)}$	See note <sup>2)</sup> Device enters stand-by mode after $t > t_{stdby}$
					tri state –	Device in stand-by mode
	1	0	OFF	ON	$I_{IS(offset)}$	LSS active
	1	1	ON	OFF	CS <sup>3)</sup>	HSS active
Slew rate selection	0	1	OFF	OFF	$I_{IS(SRx,T)}$ $I_{IS(offset)}$	Slew rate selection mode During INH = IN = low pulse
Overtemperature (OT) at HSS or LSS	1	X	OFF	OFF	$I_{IS(fault)}$	Shutdown with latch, fault detected <sup>4)</sup>
	X	1	OFF	OFF	$I_{IS(fault)}$	
Current limitation (CL) mode at HSS or LSS	1	1	OFF	ON	$I_{IS(fault)}$	Switched mode, fault detected <sup>5)</sup>
	1	0	ON	OFF	$I_{IS(fault)}$	
Overcurrent (OC) switch-OFF with latch at HSS or LSS	1	X	OFF	OFF	$I_{IS(fault)}$	OC shutdown with latch, fault detected <sup>4)</sup>
	X	1	OFF	OFF	$I_{IS(fault)}$	
Undervoltage (UV), $V_S < V_{UV(OFF)}$	1	X	OFF	OFF	* <sup>1)</sup>	

**(table continues...)**

**4 Block description and characteristics**

**Table 12 (continued) Truth table**

	X	1	OFF	OFF		Undervoltage shutdown, fault detected <sup>6)</sup>
--	---	---	-----	-----	--	---

1) Sense current present  $\leq I_{IS(\text{offset})}$ .

2) The device only goes into stand-by mode if no fault is present.

3) Current sense - high-side (CS):  $I_{IS} = I_L / dk_{ILIS} + I_{IS(\text{offset})}$ , for details see [Chapter 4.4.3.1](#).

4) Requires the reset of the fault latch with  $INH = IN = \text{low}$  for  $t_{\text{reset}}$  to get back to normal operation.

5) Will return to normal operation after  $t_{\text{CLS}}$ ; Fault signal  $I_{IS(\text{fault})}$  is reset after  $1.5 \cdot t_{\text{CLS}}$  (see [Chapter 4.3.3.1](#)).

6) When  $V_S > V_{UV(\text{ON})}$  (rising), the device will return to normal operation after  $t_{\text{UVD}}$ ; Fault signal  $I_{IS(\text{fault})}$  is reset after  $t_{\text{UVD}}$  (see [Chapter 4.3.1](#)).

**Table 13 Switches – states table**

Inputs	Switches
0 = logic LOW	OFF = switched off
1 = logic HIGH	ON = switched on
X = 0 or 1	

**4 Block description and characteristics**

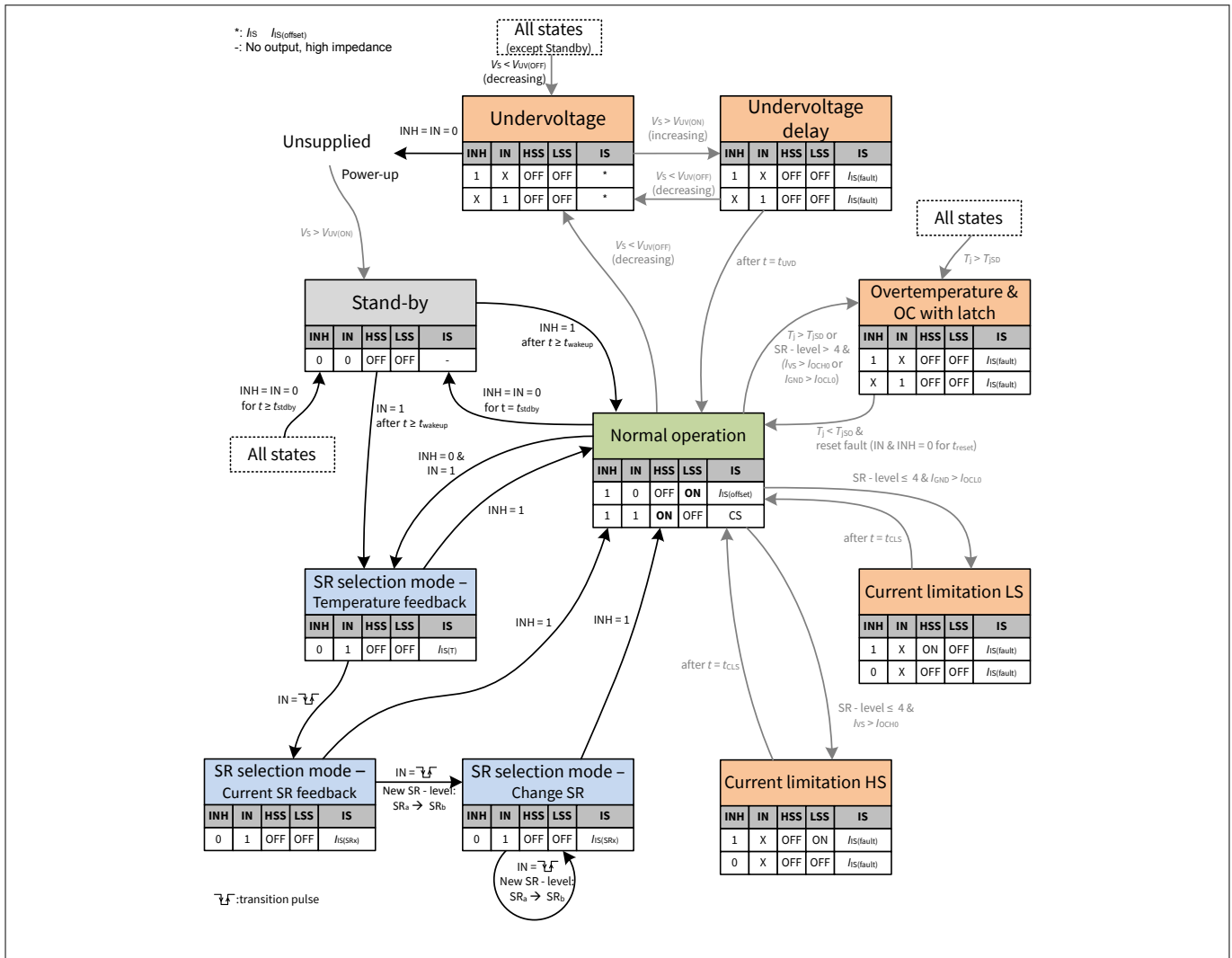
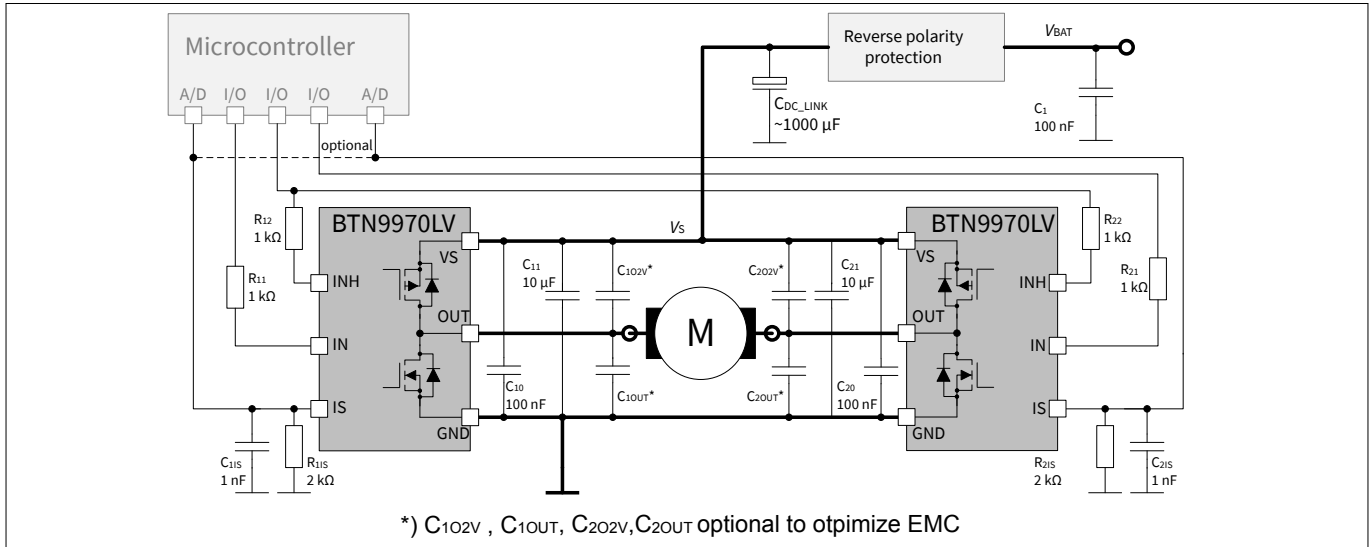

**Figure 16 Simplified state diagram**

**5 Application information**

**5 Application information**

*Note: The following information is given as a hint for the implementation of the device only and cannot be regarded as a description or warranty of a certain functionality, condition or quality of the device.*



**Figure 17 Application circuit: H-bridge with two BTN9970LV**

*Note: This is a simplified example of an application circuit. The function must be verified in the real application.*

To stabilize the supply voltage  $V_S$  in PWM operation or in over current limitation a sufficient dimensioned low ESR electrolytic capacitor CDC-Link is needed. It prevents destructive voltage peaks and drops. The voltage ripple at the NovalithIC™ VS pin to GND must be kept below 1 V peak-to-peak and the capacitors need to be sized accordingly. Therefore the ceramic capacitors C10/C11 respectively C20/C21 must be placed close to the device pins VS and GND. The traces should be kept as short as possible to minimize stray inductance. The value of the capacitors must be verified in the real application to ensure low ripple and transients at the VS pin. The digital inputs IN and INH need to be protected against over-currents (e.g. caused by induced voltage spikes) by a series resistor of typical 1 kΩ.

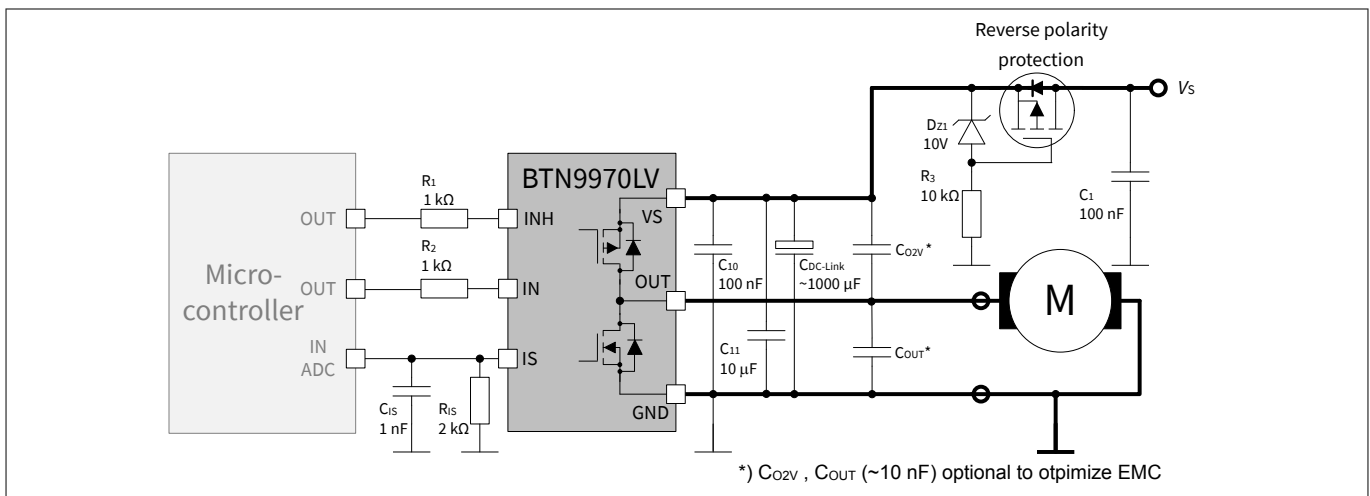

**Figure 18 Application circuit: single half-bridge with load (motor) connected to GND**

*Note: This is a simplified example of an application circuit. The function must be verified in the real application.*

## 5 Application information

The applicable PWM frequency for which the output signal at OUT pin tracks the control signal at IN pin depends on:

- Desired duty cycle range of the output OUT (e.g. 20% to 80%)
- Selected slew rate for the output OUT
- Switch-ON and switch-OFF delay times of HS / LS switches ( $t_{dr(HS)}$ ,  $t_{df(LS)}$ ,  $t_{df(HS)}$ ,  $t_{dr(LS)}$ ), depending on slew rate
- Rise-time and fall-time of HS / LS switch ( $t_{r(HS)}$ ,  $t_{f(LS)}$ ,  $t_{f(HS)}$ ,  $t_{r(LS)}$ ), depending on slew rate



**7 Revision history**

## **7 Revision history**

<b>Document version</b>	<b>Date of release</b>	<b>Description of changes</b>
1.0	2021-10-12	Initial release



## Trademarks

All referenced product or service names and trademarks are the property of their respective owners.

**Edition 2021-10-12**

**Published by**  
**Infineon Technologies AG**  
**81726 Munich, Germany**

**© 2021 Infineon Technologies AG**  
**All Rights Reserved.**

**Do you have a question about any aspect of this document?**  
**Email: [erratum@infineon.com](mailto:erratum@infineon.com)**

**Document reference**  
**IFX-hvv1633081433879**

## IMPORTANT NOTICE

The information given in this document shall in no event be regarded as a guarantee of conditions or characteristics ("Beschaffheitsgarantie").

With respect to any examples, hints or any typical values stated herein and/or any information regarding the application of the product, Infineon Technologies hereby disclaims any and all warranties and liabilities of any kind, including without limitation warranties of non-infringement of intellectual property rights of any third party.

In addition, any information given in this document is subject to customer's compliance with its obligations stated in this document and any applicable legal requirements, norms and standards concerning customer's products and any use of the product of Infineon Technologies in customer's applications.

The data contained in this document is exclusively intended for technically trained staff. It is the responsibility of customer's technical departments to evaluate the suitability of the product for the intended application and the completeness of the product information given in this document with respect to such application.

## WARNINGS

Due to technical requirements products may contain dangerous substances. For information on the types in question please contact your nearest Infineon Technologies office.

Except as otherwise explicitly approved by Infineon Technologies in a written document signed by authorized representatives of Infineon Technologies, Infineon Technologies' products may not be used in any applications where a failure of the product or any consequences of the use thereof can reasonably be expected to result in personal injury.

# Mouser Electronics

Authorized Distributor

Click to View Pricing, Inventory, Delivery & Lifecycle Information:

[Infineon:](#)

[BTN9970LVAUMA1](#)