

Features

- GaN on Si HEMT D-Mode Amplifier
- Suitable for Linear & Saturated Applications
- Broadband Operation from 20 - 1500 MHz
- 28 V Operation
- 16 dB Gain @ 1 GHz
- 42% PAE @ 1 GHz
- 100% RF Tested
- 50 Ω Input / Output Matched
- Lead-Free 4 mm 16-lead QFN plastic Package
- RoHS* Compliant and 260°C Reflow Compatible

Description

The NPA1003QA is a GaN on silicon power amplifier optimized for 20 - 1500 MHz operation. This amplifier has been designed for saturated and linear operation with output levels to 5 W (37 dBm) assembled in a lead-free 4 mm 16-lead QFN plastic package.

The NPA1003QA is ideally suited for broadband general purpose, test and measurement, defense communications, land mobile radio and wireless infrastructure.

Ordering Information

Part Number	Package
NPA1003QA	Bulk
NPA1003QA-SMBPPR	sample

Functional Schematic

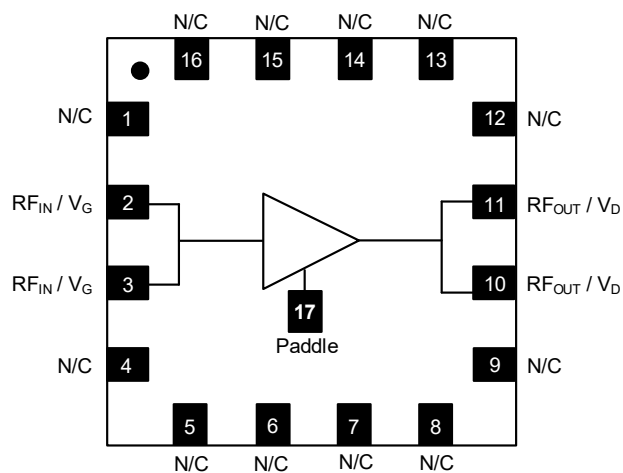

Pin Designations^{1,2}

Pin #	Pin Name	Function
1	N/C	No Connection
2, 3	RF _{IN} / V _G	RF Input / Gate Voltage
4 - 9	N/C	No Connection
10, 11	RF _{OUT} / V _D	RF Output / Drain Voltage
12 - 16	N/C	No Connection
17	Paddle ²	Ground

1. All no connection pins may be left floating or grounded.
2. The exposed pad centered on the package bottom must be connected to RF and DC ground. This path must also provide a low thermal resistance heat path.

* Restrictions on Hazardous Substances, compliant to current RoHS EU directive.

GaN Amplifier 28 V, 5 W 20 - 1500 MHz



NPA1003QA

Rev. V3

RF Electrical Specifications: $T_C = +25^\circ\text{C}$, $V_{DS} = 28\text{ V}$, $I_{DQ} = 100\text{ mA}$

Parameter	Test Conditions	Symbol	Min.	Typ.	Max.	Units
Small Signal Gain	CW, 1000 MHz	G_{SS}	—	18	—	dB
Saturated Output Power	CW, 1000 MHz	P_{SAT}	—	38.5	—	dBm
Drain Efficiency at Saturation	CW, 1000 MHz	η_{SAT}	—	50	—	%
Noise Figure	CW, 1000 MHz	NF	—	2.0	—	dB
Power Gain	CW, 1000 MHz, $P_{OUT} = 5\text{ W}$	G_P	14	16	—	%
Power Added Efficiency	CW, 1000 MHz, $P_{OUT} = 5\text{ W}$	PAE	38	42	—	%
Ruggedness	All phase angles	Ψ	VSWR=10:1, No Device Damage			

DC Electrical Specifications: $T_C = +25^\circ\text{C}$

Parameter	Test Conditions	Symbol	Min.	Typ.	Max.	Units
Drain-Source Leakage Current	$V_{GS} = -8\text{ V}$, $V_{DS} = 100\text{ V}$	I_{DLK}	—	—	2	mA
Gate-Source Leakage Current	$V_{GS} = -8\text{ V}$, $V_{DS} = 0\text{ V}$	I_{GLK}	—	—	1	mA
Gate Threshold Voltage	$V_{DS} = 28\text{ V}$, $I_D = 2\text{ mA}$	V_T	-2.9	-2.0	-0.9	V
Gate Quiescent Voltage	$V_{DS} = 28\text{ V}$, $I_D = 88\text{ mA}$	V_{GSQ}	-2.5	-1.6	-0.7	V
On Resistance	$V_{DS} = 2\text{ V}$, $I_D = 15\text{ mA}$	R_{ON}	—	1.6	—	Ω
Maximum Drain Current	$V_{DS} = 7\text{ V}$ pulsed, pulse width 300 μs	$I_{D, MAX.}$	—	1.5	—	A

Absolute Maximum Ratings^{3,4,5}

Parameter	Absolute Maximum
Drain Source Voltage, V_{DS}	100 V
Gate Source Voltage, V_{GS}	-10 to 3 V
Gate Current, I_G	4 mA
Junction Temperature, T_J	+200°C
Operating Temperature	-40°C to +85°C
Storage Temperature	-65°C to +150°C

3. Exceeding any one or combination of these limits may cause permanent damage to this device.
4. MACOM does not recommend sustained operation near these survivability limits.
5. Operating at nominal conditions with $T_J \leq 180^\circ\text{C}$ will ensure $\text{MTTF} > 1 \times 10^6$ hours.

Thermal Characteristics⁶

Parameter	Test Conditions	Symbol	Typical	Units
Thermal Resistance	$V_{DS} = 28 \text{ V}, T_J = 180^\circ\text{C}$	$R_{\theta JC}$	12	°C/W

6. Junction temperature (T_J) measured using IR Microscopy. Case temperature measured using thermocouple embedded in heat-sink.

Handling Procedures

Please observe the following precautions to avoid damage:

Static Sensitivity

Gallium Nitride Circuits are sensitive to electrostatic discharge (ESD) and can be damaged by static electricity. Proper ESD control techniques should be used when handling these HBM Class 1A devices.

Evaluation Board and Recommended Tuning Solution

20 - 1500 MHz Broadband Circuit

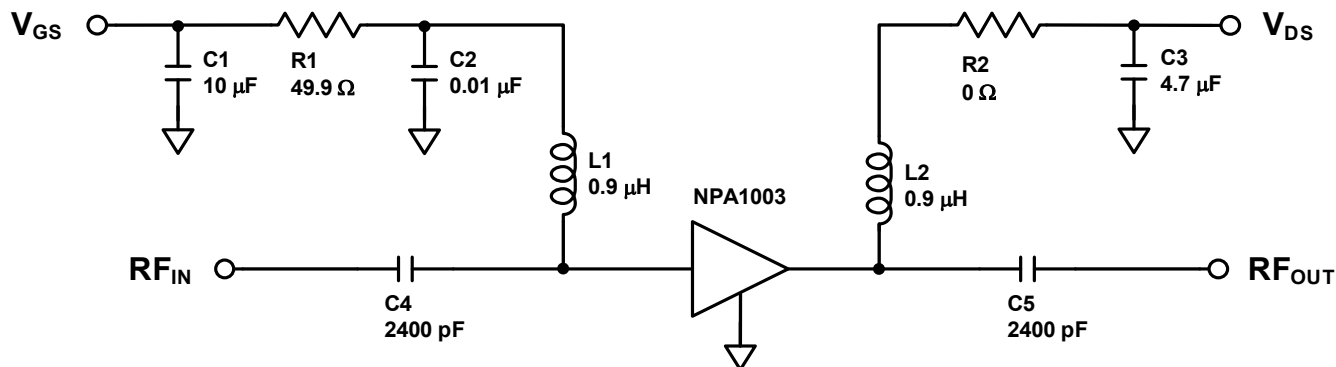

Description

Parts measured on evaluation board (20-mil thick RO4350). The PCB's electrical and thermal ground is provided using a standard-plated densely packed via pattern (see recommended via pattern).

Matching is provided using a combination of lumped elements and transmission lines as shown in the simplified schematic above. Recommended tuning solution component placement, transmission lines, and details are shown on the next page.

Bias Sequencing

Turning the device ON

1. Set V_{GS} to the pinch-off (V_P), typically -5 V.
2. Turn on V_{DS} to nominal voltage (28 V).
3. Increase V_{GS} until the I_{DS} current is reached.
4. Apply RF power to desired level.

Turning the device OFF

1. Turn the RF power off.
2. Decrease V_{GS} down to V_P .
3. Decrease V_{DS} down to 0 V.
4. Turn off V_{GS} .

Recommended Via Pattern (All dimensions shown as inches)

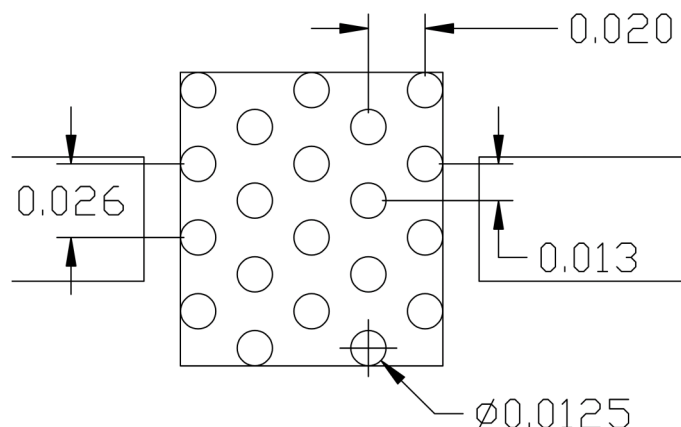

Evaluation Board and Recommended Tuning Solution

20 - 1500 MHz Broadband Circuit

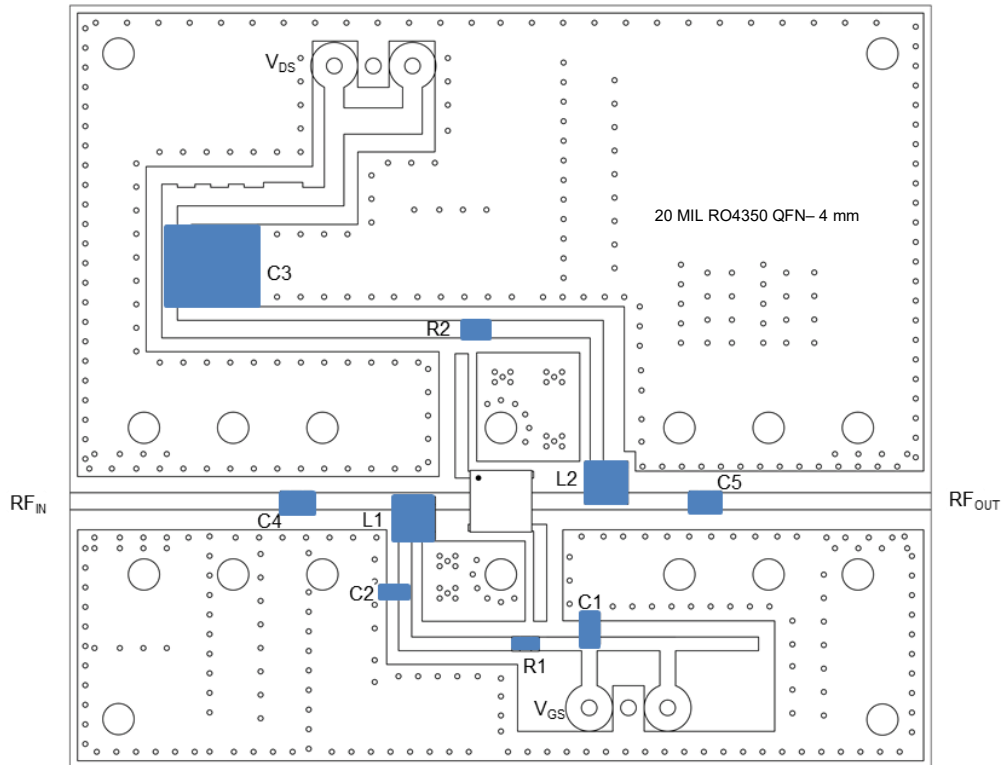

Parts list

Reference	Value	Tolerance	Manufacturer	Part Number
C1	10 μ F	20%	TDK	C2012X5R1C106M085AC
C2	0.01 μ F	5%	AVX	06031C103JAT2A
C3	4.7 μ F	10%	TDK	C5750X7R2A475K230KA
C4, C5	2400 pF	-	Dielectric Labs, Inc.	C08BL242X-5UN-X0
R1	49.9 Ω	1%	Panasonic	ERJ-6ENF49R9V
R2	0 Ω	-	Panasonic	ERJ-3GEY0R00V
L1, L2	0.9 μ H	10%	Coilcraft	1008AF-901XJLC
PCB	Rogers RO4350, $\epsilon_r = 3.5$, 0.020"			

Typical Performance as measured in the broadband evaluation board:
CW, $V_{DS} = 28$ V, $I_{DQ} = 100$ mA (unless noted)

Small Signal s-Parameters vs. Frequency

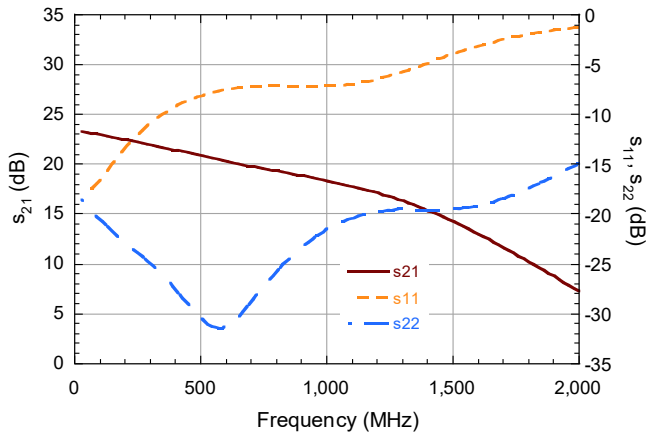

Performance vs. Frequency at $P_{OUT} = 37$ dBm

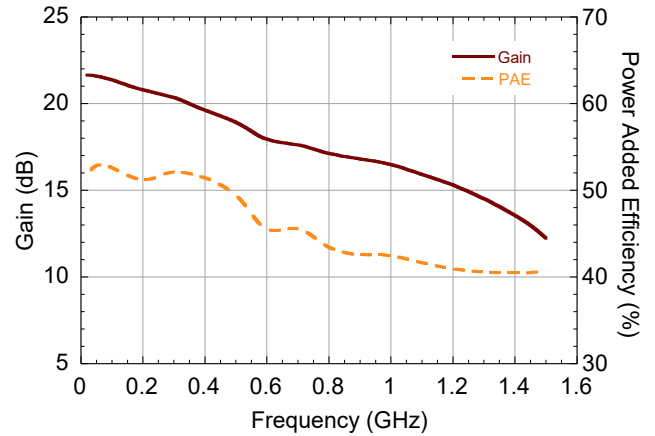

Gain vs. Frequency

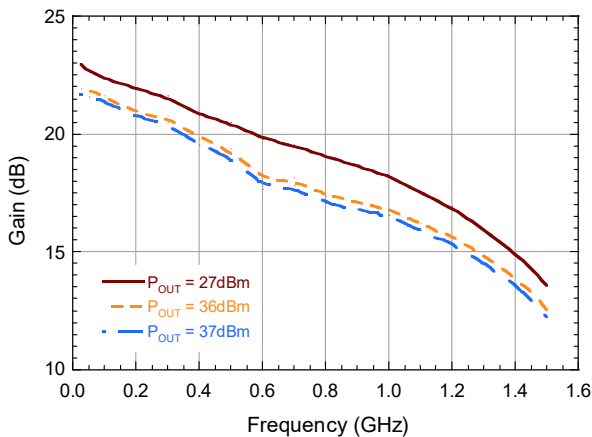

Power Added Efficiency vs. Frequency

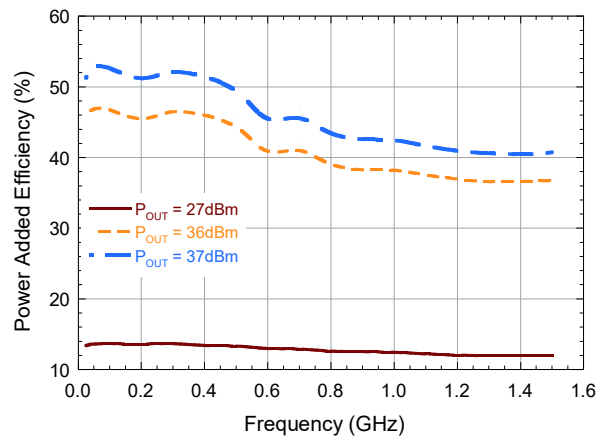

Gain vs. Frequency at $P_{OUT} = 37$ dBm

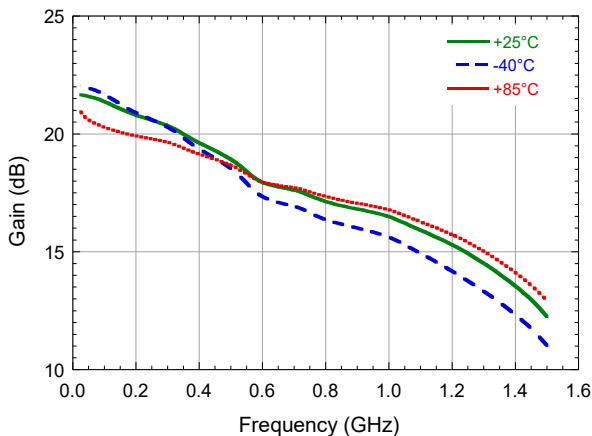

Power Added Efficiency vs. Frequency at $P_{OUT} = 37$ dBm

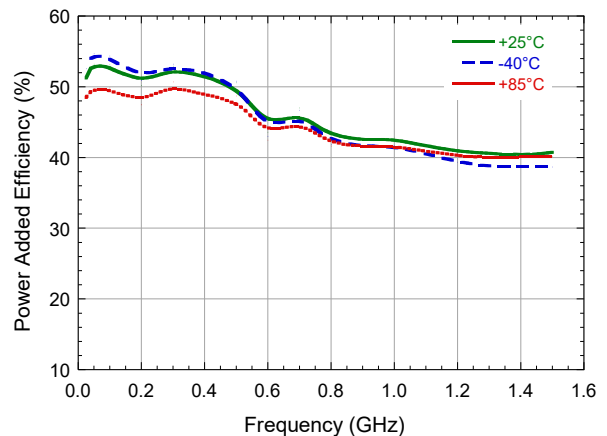

Typical Performance as measured in the broadband evaluation board:
CW, $V_{DS} = 28$ V, $I_{DQ} = 100$ mA (unless noted)

Input Return Loss vs. Frequency at $P_{OUT} = 37$ dBm

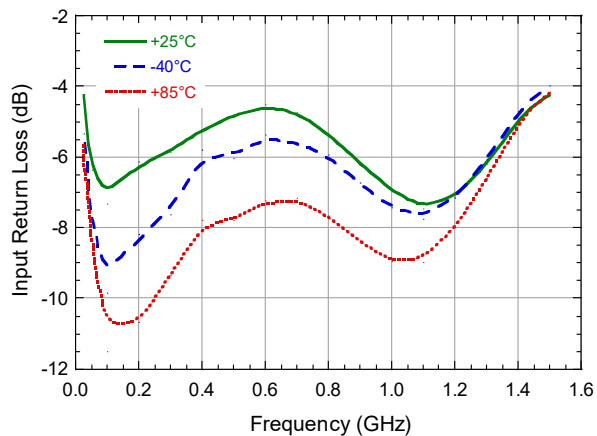

Input Return Loss vs. Output Power

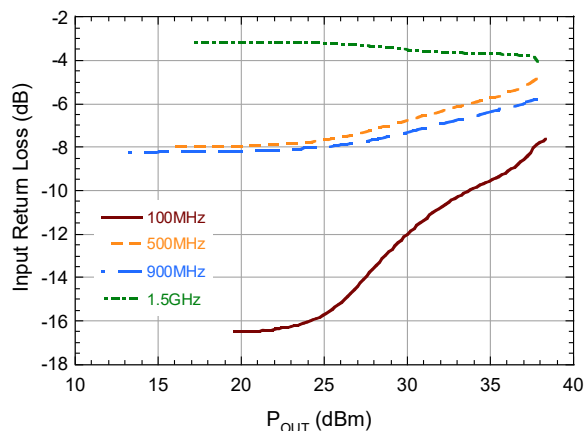

Gain vs. Output Power

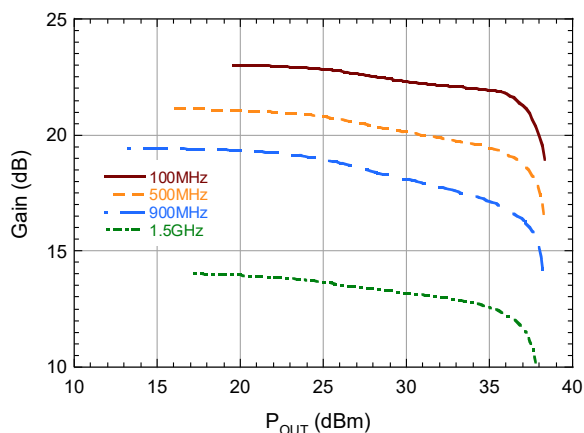

Power Added Efficiency vs. Output Power

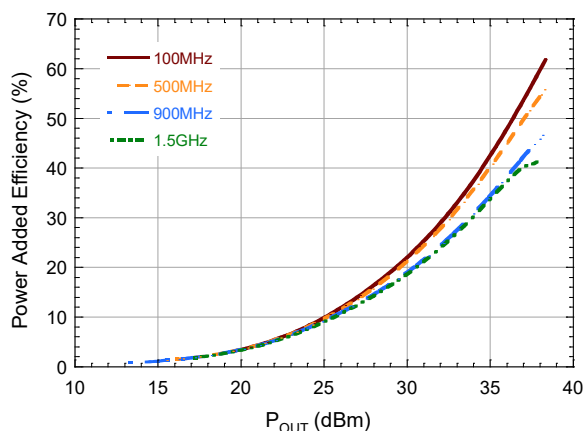

Typical Performance as measured in the broadband evaluation board:
CW, $V_{DS} = 28\text{ V}$, $I_{DQ} = 100\text{ mA}$ (unless noted)

Gain vs. Output Power
at freq = 900 MHz

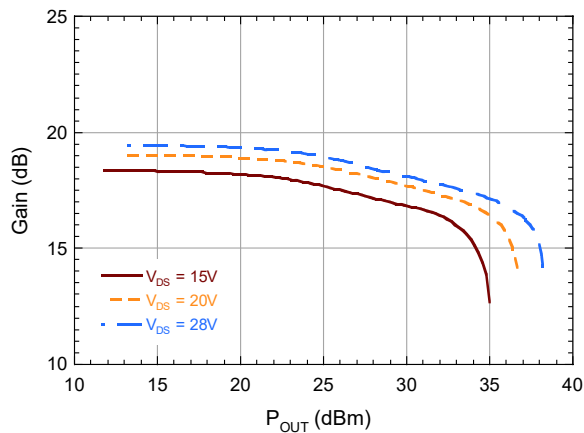

Power Added Efficiency vs. Output Power
at freq = 900 MHz

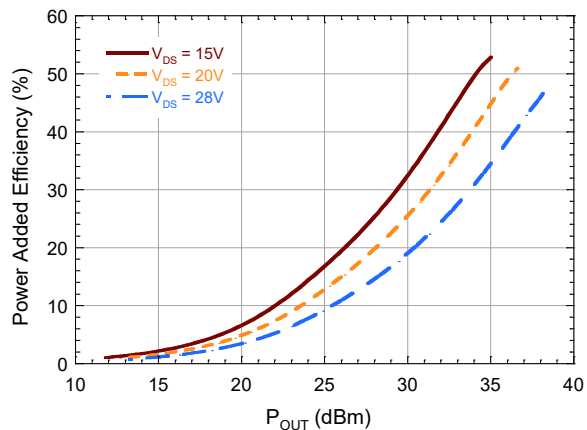

Quiescent V_{GS} vs. Temperature

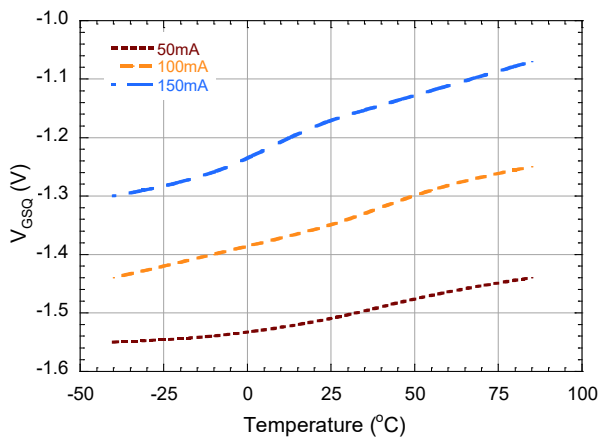

Typical 2-Tone Performance as measured in the broadband evaluation board:
1 MHz Tone Spacing, $f = 500$ MHz, $V_{DS} = 28$ V, $I_{DQ} = 100$ mA (unless noted)

2-Tone IMD3 vs. Output Power vs. Quiescent Current

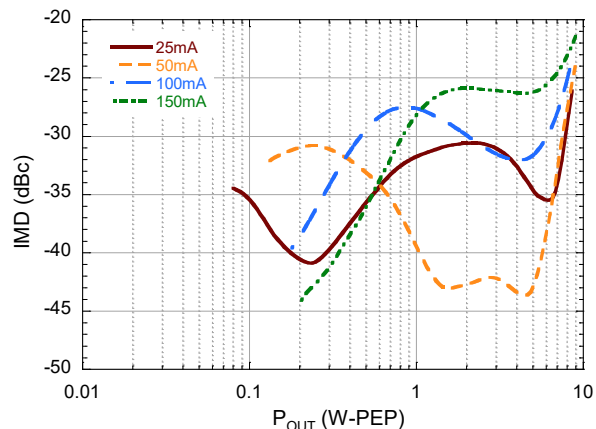

2-Tone Gain vs. Output Power vs. Quiescent Current

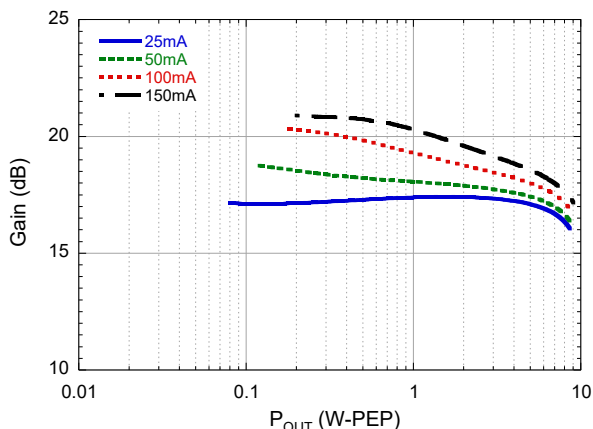

2-Tone IMD vs. Output Power

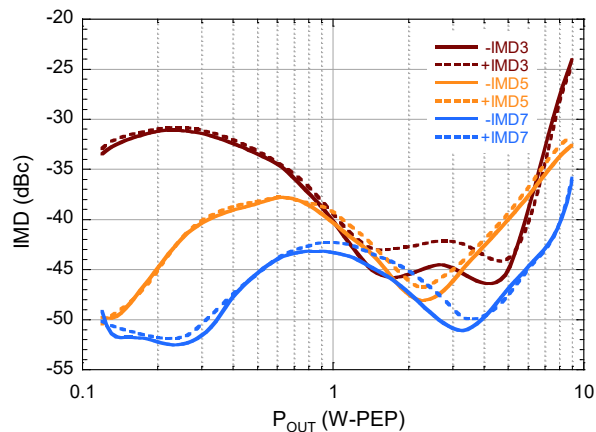

2-Tone IMD vs. Tone Spacing
at $P_{OUT} = 6$ W-PEP, $I_{DQ} = 6$ mA

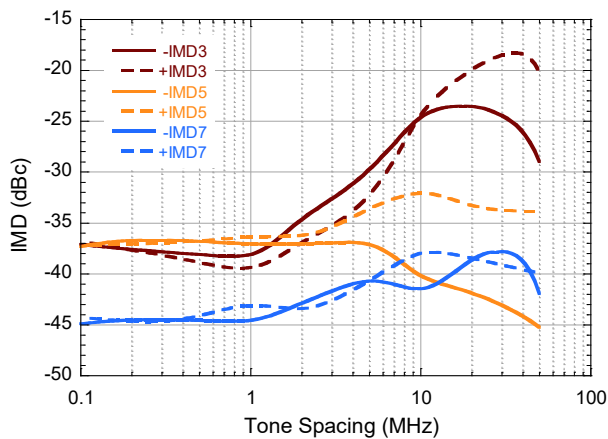

Lead-Free 4 mm QFN 16-lead plastic package

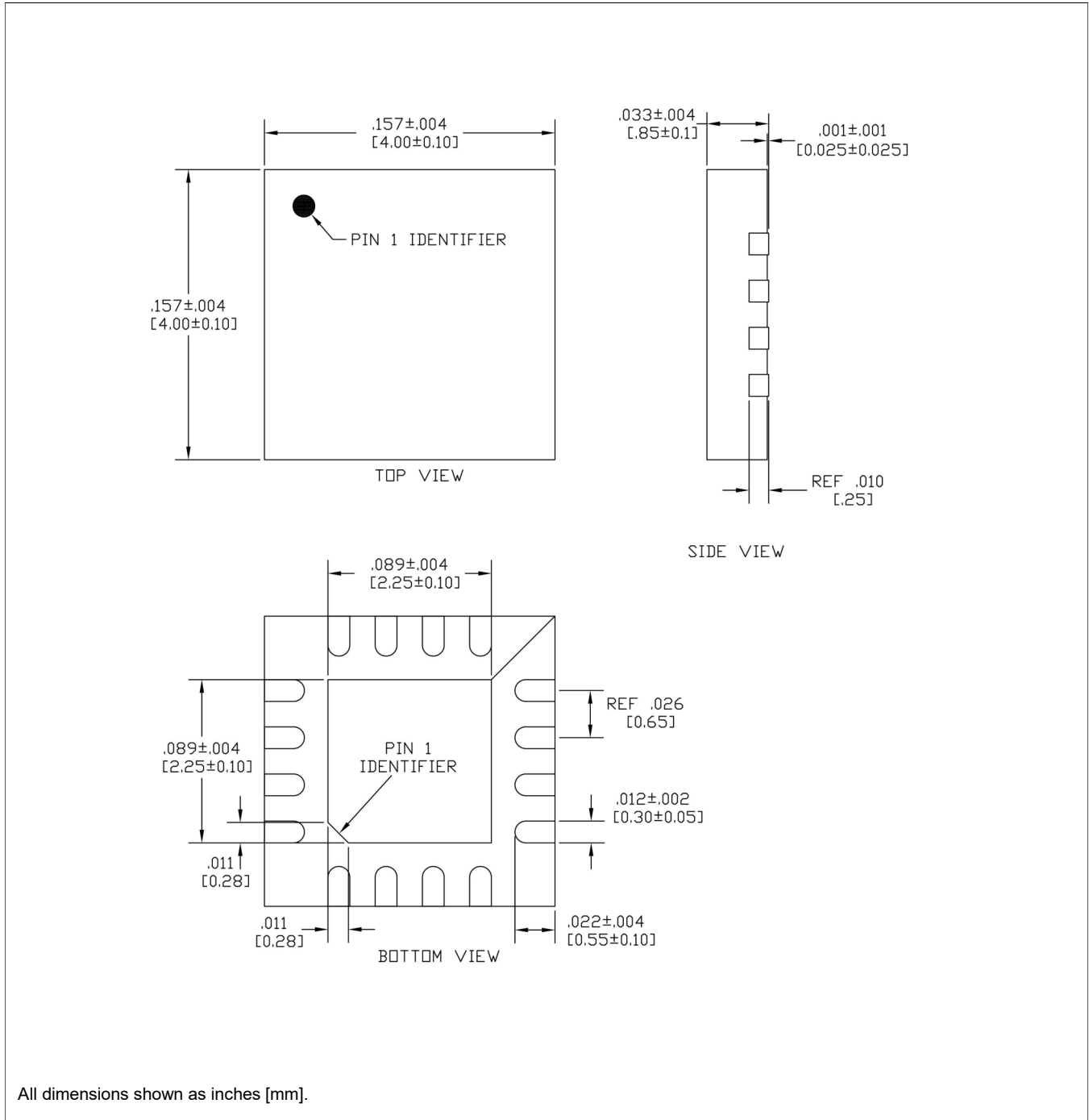

† Meets JEDEC moisture sensitivity level 3 requirements.
Plating is 100% matte tin over copper.

MACOM Technology Solutions Inc. ("MACOM"). All rights reserved.

These materials are provided in connection with MACOM's products as a service to its customers and may be used for informational purposes only. Except as provided in its Terms and Conditions of Sale or any separate agreement, MACOM assumes no liability or responsibility whatsoever, including for (i) errors or omissions in these materials; (ii) failure to update these materials; or (iii) conflicts or incompatibilities arising from future changes to specifications and product descriptions, which MACOM may make at any time, without notice. These materials grant no license, express or implied, to any intellectual property rights.

THESE MATERIALS ARE PROVIDED "AS IS" WITH NO WARRANTY OR LIABILITY, EXPRESS OR IMPLIED, RELATING TO SALE AND/OR USE OF MACOM PRODUCTS INCLUDING FITNESS FOR A PARTICULAR PURPOSE, MERCHANTABILITY, INFRINGEMENT OF INTELLECTUAL PROPERTY RIGHT, ACCURACY OR COMPLETENESS, OR SPECIAL, INDIRECT, INCIDENTAL, OR CONSEQUENTIAL DAMAGES WHICH MAY RESULT FROM USE OF THESE MATERIALS.

MACOM products are not intended for use in medical, lifesaving or life sustaining applications. MACOM customers using or selling MACOM products for use in such applications do so at their own risk and agree to fully indemnify MACOM for any damages resulting from such improper use or sale.