

Smart Highside Power Switch

Features

- Load dump and reverse battery protection¹⁾
- Clamp of negative voltage at output
- Short-circuit protection
- Current limitation
- Thermal shutdown
- Diagnostic feedback
- Open load detection in OFF-state
- CMOS compatible input
- **Electrostatic discharge (ESD)** protection
- Loss of ground and loss of V_{bb} protection²⁾
- Overvoltage protection
- Undervoltage and overvoltage shutdown with auto-restart and hysteresis

Application

- μ C compatible power switch with diagnostic feedback for 12 V and 24 V DC grounded loads
- All types of resistive, inductive and capacitive loads
- Replaces electromechanical relays and discrete circuits

General Description

N channel vertical power FET with charge pump, ground referenced CMOS compatible input and diagnostic feedback, integrated in Smart SIPMOS[®] chip on chip technology. Fully protected by embedded protection functions.

Product Summary

$V_{Load\ dump}$	80	V
$V_{bb}-V_{OUT}$ Avalanche Clamp	58	V
V_{bb} (operation)	4.5 ... 42	V
V_{bb} (reverse)	-32	V
R_{ON}	38	m Ω
$I_L(SCp)$	42	A
$I_L(SCr)$	33	A
$I_L(ISO)$	11	A

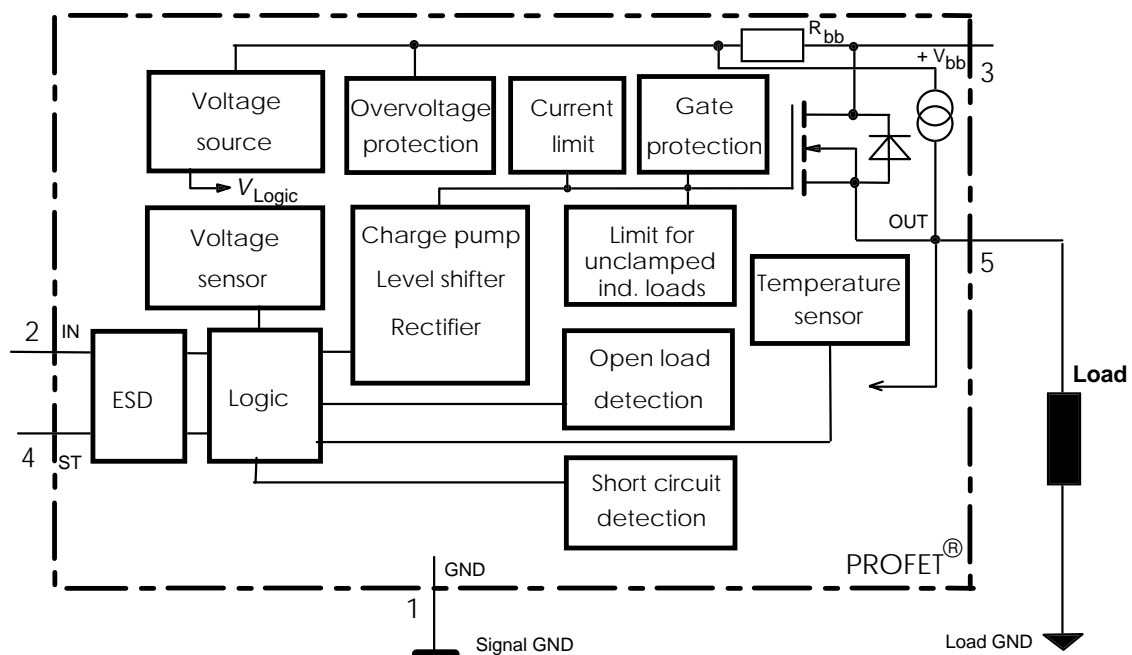
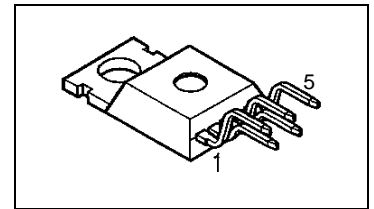

1) No external components required, reverse load current limited by connected load.

2) Additional external diode required for charged inductive loads

Pin	Symbol		Function
1	GND	-	Logic ground
2	IN	I	Input, activates the power switch in case of logical high signal
3	V _{bb}	+	Positive power supply voltage, the tab is shorted to this pin
4	ST	S	Diagnostic feedback, low on failure
5	OUT (Load, L)	O	Output to the load

Maximum Ratings at T_j = 25 °C unless otherwise specified

Parameter	Symbol	Values	Unit	
Supply voltage (overvoltage protection see page 3)	V _{bb}	63	V	
Load dump protection V _{LoadDump} = U _A + V _S , U _A = 13.5 V R _I = 2 Ω, R _L = 1.1 Ω, t _d = 200 ms, IN = low or high	V _S ³⁾	66.5	V	
Load current (Short-circuit current, see page 4)	I _L	self-limited	A	
Operating temperature range	T _j	-40 ... +150	°C	
Storage temperature range	T _{stg}	-55 ... +150		
Power dissipation (DC)	P _{tot}	125	W	
Inductive load switch-off energy dissipation, single pulse T _j = 150 °C:	E _{AS}	1.7	J	
Electrostatic discharge capability (ESD) (Human Body Model)	V _{ESD}	2.0	kV	
Input voltage (DC)	V _{IN}	-0.5 ... +6	V	
Current through input pin (DC)	I _{IN}	±5.0	mA	
Current through status pin (DC)	I _{ST}	±5.0		
see internal circuit diagrams page 6...				
Thermal resistance	chip - case: junction - ambient (free air): SMD version, device on pcb ⁴⁾ :	R _{thJC} R _{thJA}	≤ 1 ≤ 75 ≤ tbd	K/W

3) V_S is setup without DUT connected to the generator per ISO 7637-1 and DIN 40839

4) Device on 50mm*50mm*1.5mm epoxy PCB FR4 with 6cm² (one layer, 70μm thick) copper area for V_{bb} connection. PCB is vertical without blown air.

Electrical Characteristics

Parameter and Conditions at $T_j = 25\text{ °C}$, $V_{bb} = 12\text{ V}$ unless otherwise specified	Symbol	Values			Unit
		min	typ	max	

Load Switching Capabilities and Characteristics

On-state resistance (pin 3 to 5) $I_L = 2\text{ A}$	$T_j = 25\text{ °C}$: $T_j = 150\text{ °C}$:	R_{ON}	--	30 55	38 70	mΩ
Nominal load current (pin 3 to 5) ISO Proposal: $V_{ON} = 0.5\text{ V}$, $T_C = 85\text{ °C}$		$I_{L(ISO)}$	9	11	--	A
Output current (pin 5) while GND disconnected or GND pulled up, $V_{IN} = 0$, see diagram page 7, $T_j = -40\dots+150\text{ °C}$		$I_{L(GNDhigh)}$	--	--	1	mA
Turn-on time to 90% V_{OUT} :		t_{on}	50	160	300	μs
Turn-off time to 10% V_{OUT} :		t_{off}	10	--	80	
Slew rate on 10 to 30% V_{OUT} , $R_L = 12\text{ Ω}$, $T_j = -40\dots+150\text{ °C}$		dV/dt_{on}	0.4	--	2.5	V/μs
Slew rate off 70 to 40% V_{OUT} , $R_L = 12\text{ Ω}$, $T_j = -40\dots+150\text{ °C}$		$-dV/dt_{off}$	1	--	5	V/μs

Operating Parameters

Operating voltage ⁵⁾	$T_j = -40\dots+150\text{ °C}$:	$V_{bb(on)}$	4.5	--	42	V
Undervoltage shutdown	$T_j = -40\dots+150\text{ °C}$:	$V_{bb(under)}$	2.4	--	4.5	V
Undervoltage restart	$T_j = -40\dots+150\text{ °C}$:	$V_{bb(u\text{ rst})}$	--	--	4.5	V
Undervoltage restart of charge pump see diagram page 12	$T_j = -40\dots+150\text{ °C}$:	$V_{bb(ucp)}$	--	6.5	7.5	V
Undervoltage hysteresis $\Delta V_{bb(under)} = V_{bb(u\text{ rst})} - V_{bb(under)}$		$\Delta V_{bb(under)}$	--	0.2	--	V
Overvoltage shutdown	$T_j = -40\dots+150\text{ °C}$:	$V_{bb(over)}$	42	--	52	V
Overvoltage restart	$T_j = -40\dots+150\text{ °C}$:	$V_{bb(o\text{ rst})}$	42	--	--	V
Overvoltage hysteresis	$T_j = -40\dots+150\text{ °C}$:	$\Delta V_{bb(over)}$	--	0.2	--	V
Overvoltage protection ⁶⁾ $I_{bb} = 40\text{ mA}$	$T_j = -40\text{ °C}$: $T_j = 25\dots+150\text{ °C}$:	$V_{bb(AZ)}$	60 63	-- 67	--	V
Standby current (pin 3) $V_{IN} = 0$, $I_{ST} = 0$,	$T_j = -40\dots+25\text{ °C}$: $T_j = 150\text{ °C}$:	$I_{bb(off)}$	--	40 50	70 110	μA
Operating current (Pin 1) ⁷⁾ , $V_{IN} = 5\text{ V}$		I_{GND}	--	1.1	--	mA

5) At supply voltage increase up to $V_{bb} = 6.5\text{ V}$ typ without charge pump, $V_{OUT} \approx V_{bb} - 2\text{ V}$

6) see also $V_{ON(CL)}$ in table of protection functions and circuit diagram page 7. Measured without load.

7) Add I_{ST} , if $I_{ST} > 0$, add I_{IN} , if $V_{IN} > 5.5\text{ V}$

Parameter and Conditions at $T_j = 25\text{ °C}$, $V_{bb} = 12\text{ V}$ unless otherwise specified	Symbol	Values			Unit
		min	typ	max	
Protection Functions					
Initial peak short circuit current limit (pin 3 to 5) ⁸⁾ , (max 400 μs if $V_{ON} > V_{ON(SC)}$) $T_j = -40\text{ °C}$: $T_j = 25\text{ °C}$: $T_j = +150\text{ °C}$:	$I_{L(SCp)}$	--	--	72	A
Repetitive short circuit current limit $T_j = T_{jt}$ (see timing diagrams, page 10)	$I_{L(SCr)}$	20	33	--	A
Short circuit shutdown delay after input pos. slope $V_{ON} > V_{ON(SC)}$, min value valid only, if input "low" time exceeds 30 μs $T_j = -40..+150\text{ °C}$:	$t_{d(SC)}$	80	--	400	μs
Output clamp (inductive load switch off) at $V_{OUT} = V_{bb} - V_{ON(CL)}$, $I_L = 30\text{ mA}$	$V_{ON(CL)}$	--	58	--	V
Short circuit shutdown detection voltage (pin 3 to 5)	$V_{ON(SC)}$	--	8.3	--	V
Thermal overload trip temperature	T_{jt}	150	--	--	°C
Thermal hysteresis	ΔT_{jt}	--	10	--	K
Inductive load switch-off energy dissipation ⁹⁾ , $T_{j\text{Start}} = 150\text{ °C}$, single pulse $V_{bb} = 12\text{ V}$: $V_{bb} = 24\text{ V}$:	E_{AS} E_{Load12} E_{Load24}	--	--	1.7 1.3 1.0	J
Reverse battery (pin 3 to 1) ¹⁰⁾	$-V_{bb}$	--	--	32	V
Integrated resistor in V_{bb} line	R_{bb}	--	120	--	Ω

Diagnostic Characteristics



Open load detection current	$I_{L(off)}$	10	30	60	μA
Open load detection voltage $T_j = -40..150\text{ °C}$:	$V_{OUT(OL)}$	2	3	4	V

8) Short circuit current limit for max. duration of 400 μs , prior to shutdown (see $t_{d(SC)}$ page 4)

9) While demagnetizing load inductance, dissipated energy in PROFET is $E_{AS} = \int V_{ON(CL)} * I_L(t) dt$, approx.

$$E_{AS} = \frac{1}{2} * L * I_L^2 * \left(\frac{V_{ON(CL)}}{V_{ON(CL)} - V_{bb}} \right), \text{ see diagram page 8}$$

10) Reverse load current (through intrinsic drain-source diode) is normally limited by the connected load. Reverse current I_{GND} of $\approx 0.3\text{ A}$ at $V_{bb} = -32\text{ V}$ through the logic heats up the device. Time allowed under these condition is dependent on the size of the heatsink. Reverse I_{GND} can be reduced by an additional external GND-resistor (150 Ω). Input and Status currents have to be limited (see max. ratings page 2 and circuit page 7).

Parameter and Conditions at $T_j = 25\text{ °C}$, $V_{bb} = 12\text{ V}$ unless otherwise specified	Symbol	Values			Unit
		min	typ	max	
Input and Status Feedback¹¹⁾					
Input turn-on threshold voltage  $T_j = -40..+150\text{ °C}$:	$V_{IN(T+)}$	1.5	--	2.4	V
Input turn-off threshold voltage  $T_j = -40..+150\text{ °C}$:	$V_{IN(T-)}$	1.0	--	--	V
Input threshold hysteresis	$\Delta V_{IN(T)}$	--	0.5	--	V
Off state input current (pin 2) $V_{IN} = 0.4\text{ V}$:	$I_{IN(off)}$	1	--	30	μA
On state input current (pin 2) $V_{IN} = 3.5\text{ V}$:	$I_{IN(on)}$	10	25	50	μA
Delay time for status with open load after Input neg. slope (see diagram page 12)	$t_{d(ST\ OL3)}$	40	--	300	μs
Status invalid after positive input slope (short circuit) $T_j = -40 \dots +150\text{ °C}$:	$t_{d(ST\ SC)}$	80	200	400	μs
Status output (CMOS) $T_j = -40\dots+150\text{ °C}$, $I_{ST} = -50\ \mu\text{A}$:	$V_{ST(high)}^{12)}$	4.4	5.1	6.5	V
$T_j = -40\dots+150\text{ °C}$, $I_{ST} = +1.6\text{ mA}$:	$V_{ST(low)}$	--	--	0.4	
Max. status current for valid status output, $T_j = -40\dots+150\text{ °C}$	current source (out): $-I_{ST}$	--	--	0.25	mA
	current sink (in) : $+I_{ST}^{13)}$	--	--	1.6	

11) If a ground resistor R_{GND} is used, add the voltage drop across this resistor.

12) $V_{St\ high} \approx V_{bb}$ during undervoltage shutdown

13) No current sink capability during undervoltage shutdown

Truth Table

	Input-level	Output level	Status		
			432 D2	432 E2/F2	432 I2
Normal operation	L	L	H	H	H
	H	H	H	H	H
Open load	L	¹⁴⁾	H	H	L
	H	H	L	L	H
Short circuit to GND	L	L	H	H	H
	H	L	L	L	L
Short circuit to V _{bb}	L	H	H (L ¹⁵⁾)	H (L ¹⁵⁾)	L
	H	H	H (L ¹⁵⁾)	H (L ¹⁵⁾)	H
Overtemperature	L	L	L	L	L
	H	L	L	L	L
Undervoltage	L	L	L ¹⁶⁾	H	L ¹⁶⁾
	H	L	L ¹⁶⁾	H	L ¹⁶⁾
Overvoltage	L	L	L	H	L
	H	L	L	H	L

L = "Low" Level
H = "High" Level

Terms

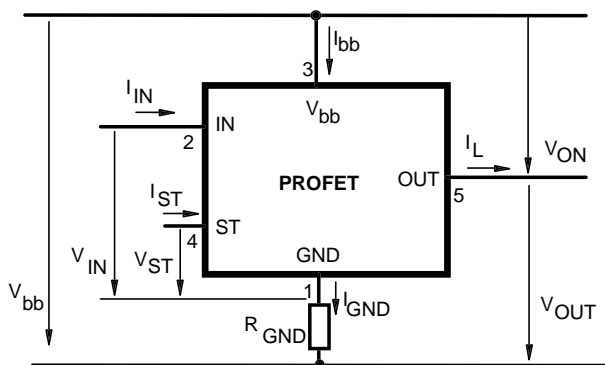

Input circuit (ESD protection)

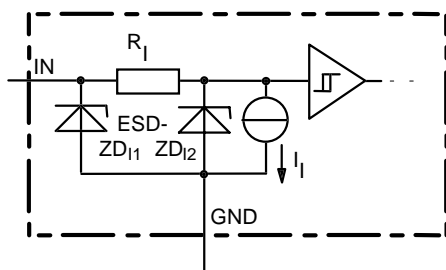

ZD11 6.1 V typ., ESD zener diodes are not designed for continuous current

Status output

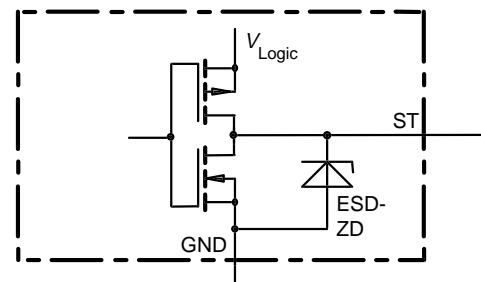

Zener diode: 6.1 V typ., max 5 mA, V_{Logic} 5 V typ, ESD zener diodes are not designed for continuous current

Short Circuit detection

Fault Condition: V_{ON} > 8.3 V typ.; IN high

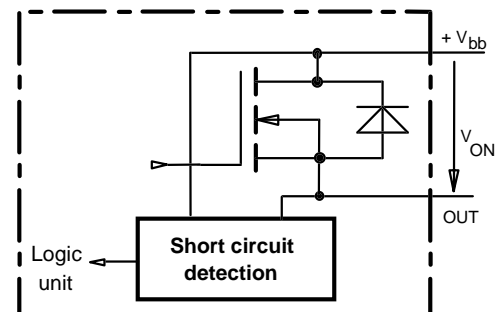

- 14) Power Transistor off, high impedance
- 15) Low resistance short V_{bb} to output may be detected by no-load-detection
- 16) No current sink capability during undervoltage shutdown

Inductive and overvoltage output clamp

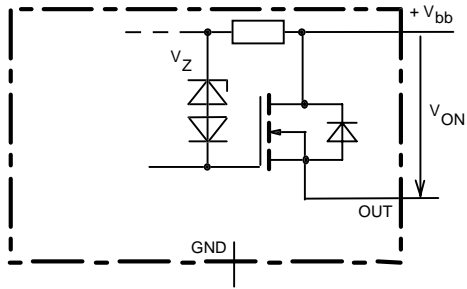

V_{ON} clamped to 58 V typ.

Overvolt. and reverse batt. protection

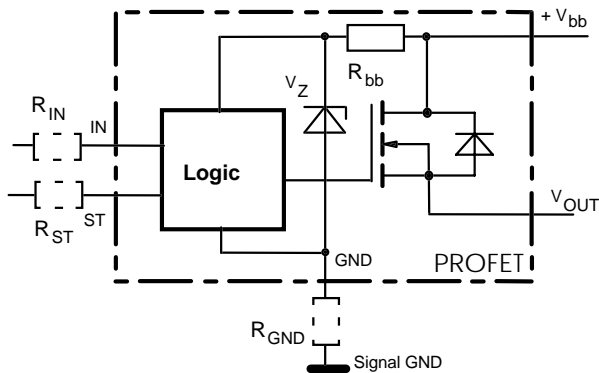

$R_{bb} = 120 \Omega$ typ., $V_Z + R_{bb} \cdot 40 \text{ mA} = 67 \text{ V}$ typ., add R_{GND} , R_{IN} , R_{ST} for extended protection

Open-load detection

OFF-state diagnostic condition: $V_{OUT} > 3 \text{ V}$ typ.; IN low

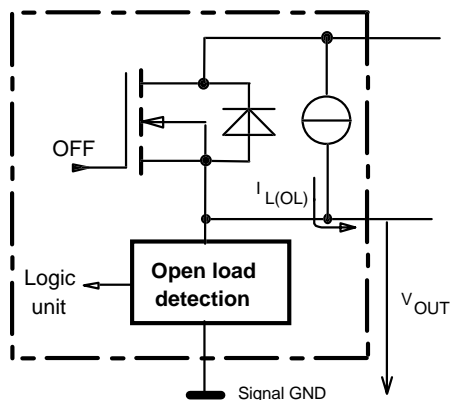

GND disconnect

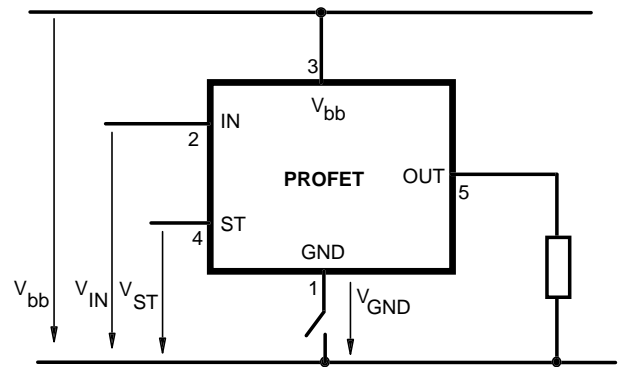

Any kind of load. In case of Input=high is $V_{OUT} \approx V_{IN} - V_{IN(T+)}$. Due to $V_{GND} > 0$, no $V_{ST} = \text{low}$ signal available.

GND disconnect with GND pull up

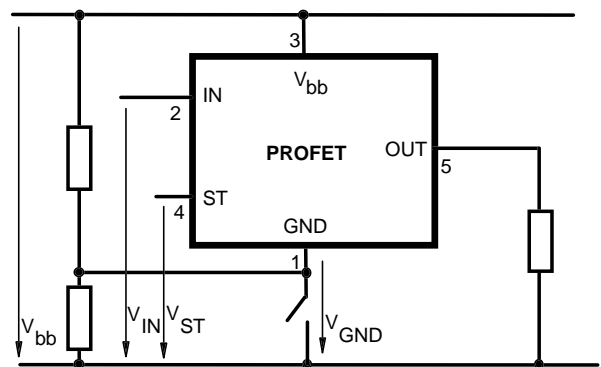

Any kind of load. If $V_{GND} > V_{IN} - V_{IN(T+)}$ device stays off. Due to $V_{GND} > 0$, no $V_{ST} = \text{low}$ signal available.

Vbb disconnect with charged inductive load

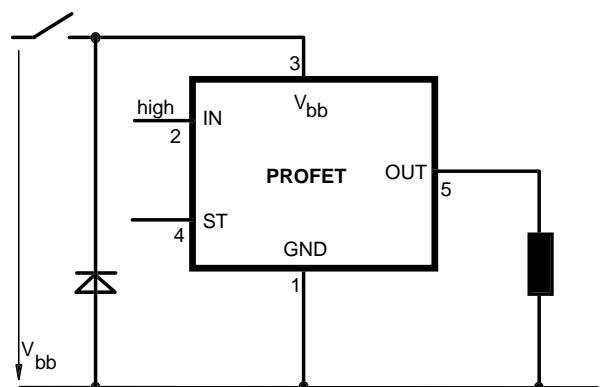
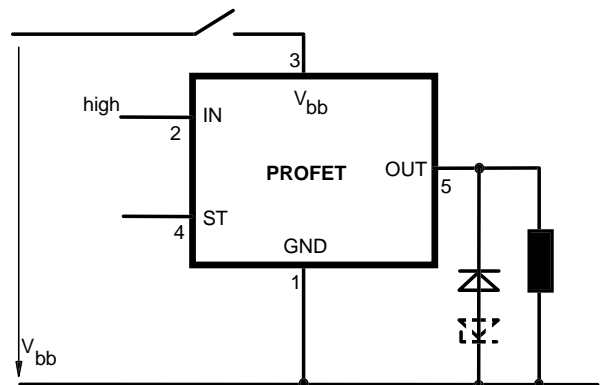

Inductive Load switch-off energy dissipation

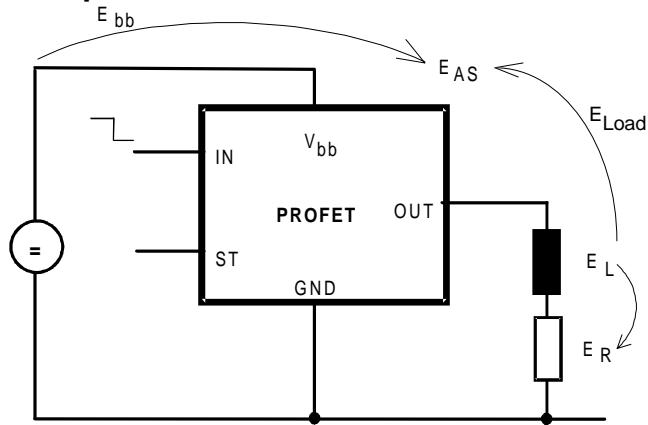

Energy dissipated in PROFET $E_{AS} = E_{bb} + E_L - E_R$.

$$E_{Load} < E_L, E_L = \frac{1}{2} * L * I_L^2$$

Options Overview

all versions: High-side switch, Input protection, ESD protection, load dump and reverse battery protection , protection against loss of ground

Type	BTS	432D2	432E2	432F2	432I2
Logic version	D	E	F	I	
Overtemperature protection $T_j > 150\text{ °C}$, latch function ¹⁷⁾¹⁸⁾ $T_j > 150\text{ °C}$, with auto-restart on cooling	X		X	X	X
Short-circuit to GND protection switches off when $V_{ON} > 8.3\text{ V}$ typ. ¹⁷⁾ (when first turned on after approx. 200 μs)	X	X	X	X	X
Open load detection in OFF-state with sensing current 30 μA typ. in ON-state with sensing voltage drop across power transistor	X	X	X		X
Undervoltage shutdown with auto restart	X	X	X	X	X
Overvoltage shutdown with auto restart	X	X	X	X	X
Status feedback for					
overtemperature	X	X	X	X	X
short circuit to GND	X	X	X	X	X
short to V_{bb}	- ¹⁹⁾	- ¹⁹⁾	- ¹⁹⁾		X
open load	X	X	X	X	X
undervoltage	X	-	-	-	X
overvoltage	X	-	-	-	X
Status output type					
CMOS	X				X
Open drain		X	X		
Output negative voltage transient limit (fast inductive load switch off) to $V_{bb} - V_{ON(CL)}$	X	X	X	X	X
Load current limit					
high level (can handle loads with high inrush currents)	X	X			
medium level					X
low level (better protection of application)			X		

¹⁷⁾ Latch except when $V_{bb} - V_{OUT} < V_{ON(SC)}$ after shutdown. In most cases $V_{OUT} = 0\text{ V}$ after shutdown ($V_{OUT} \neq 0\text{ V}$ only if forced externally). So the device remains latched unless $V_{bb} < V_{ON(SC)}$ (see page 4). No latch between turn on and $t_{d(SC)}$.

¹⁸⁾ With latch function. Reseted by a) Input low, b) Undervoltage, c) Overvoltage

¹⁹⁾ Low resistance short V_{bb} to output may be detected by no-load-detection

Timing diagrams

Figure 1a: V_{bb} turn on:

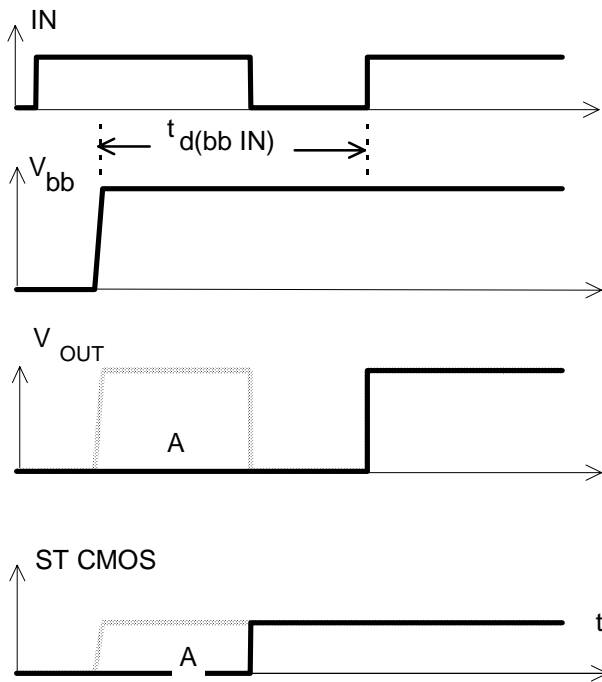

in case of too early V_{IN} =high the device may not turn on (curve A)
 $t_{d(bb IN)}$ approx. 150 μ s

Figure 2a: Switching a lamp,

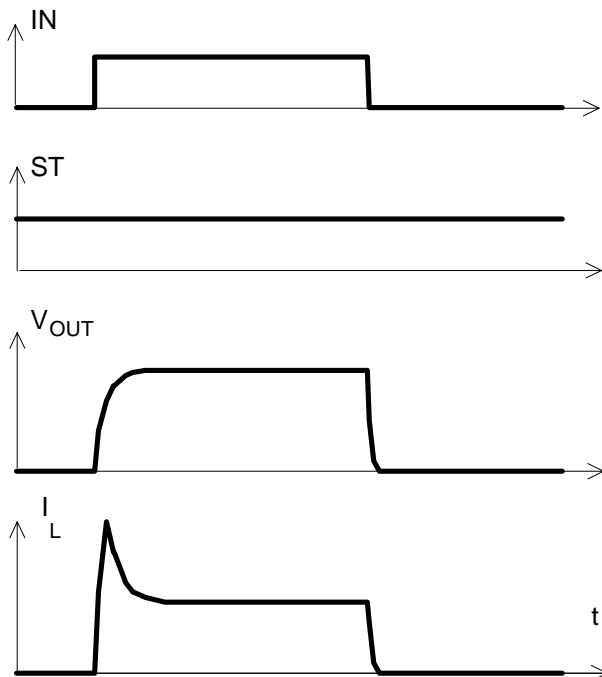

Figure 2b: Switching an inductive load

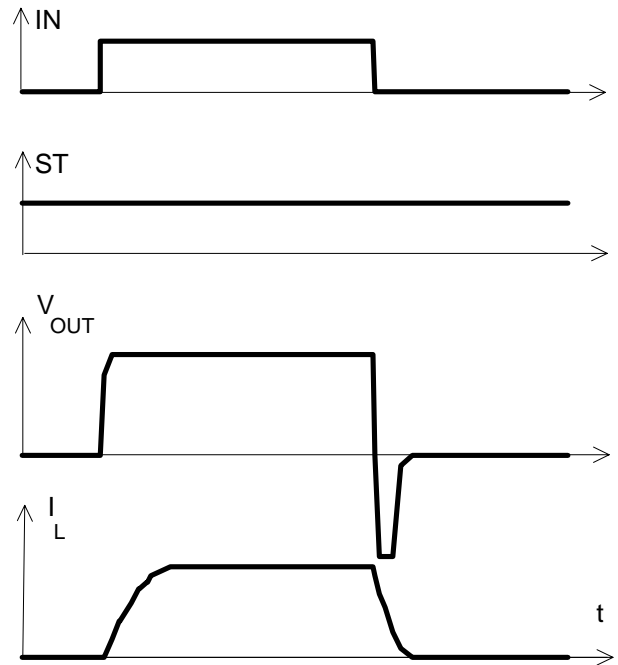
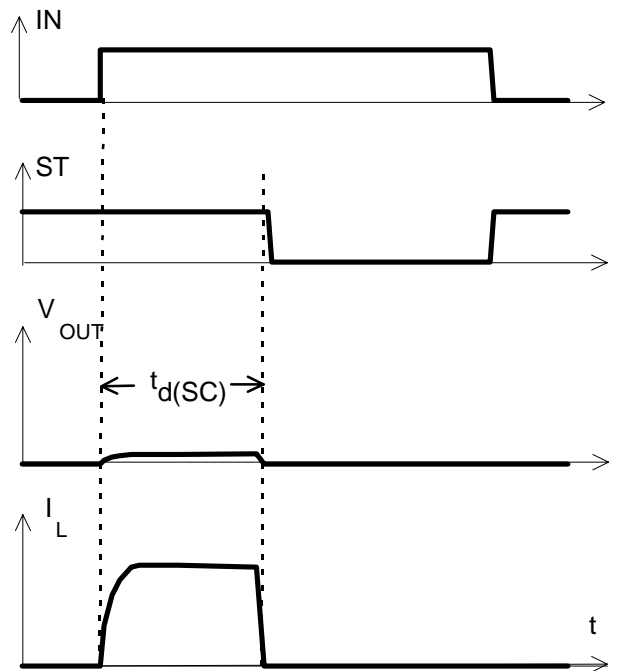
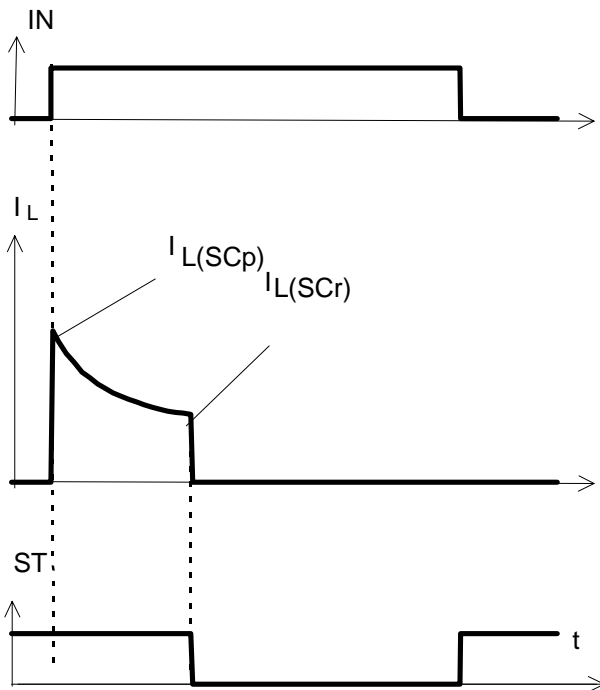

Figure 3a: Turn on into short circuit,



$t_{d(SC)}$ approx. 200 μ s if $V_{bb} - V_{OUT} > 8.3$ V typ.

Figure 3b: Turn on into overload,



Heating up may require several milliseconds, $V_{bb} - V_{OUT} < 8.3 V$ typ.

Figure 3c: Short circuit while on:

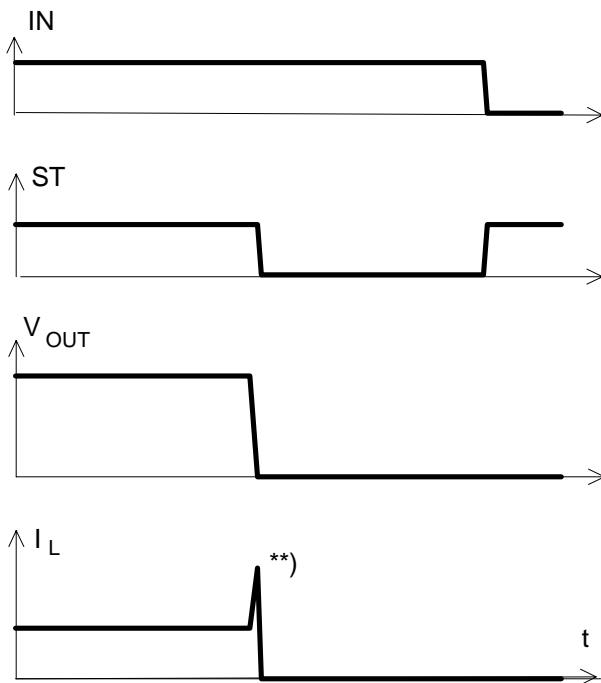

****)** current peak approx. 20 μs

Figure 4a: Overtemperature,

Reset if $(IN=low)$ and $(T_j < T_{jt})$

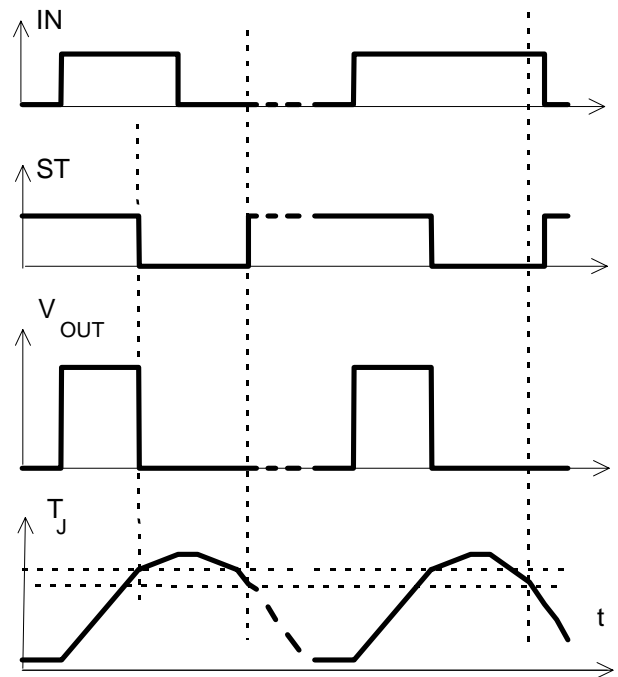

***)** ST goes high, when $V_{IN}=low$ and $T_j < T_{jt}$

Figure 5a: Open load: detection in ON-state, open load occurs in on-state

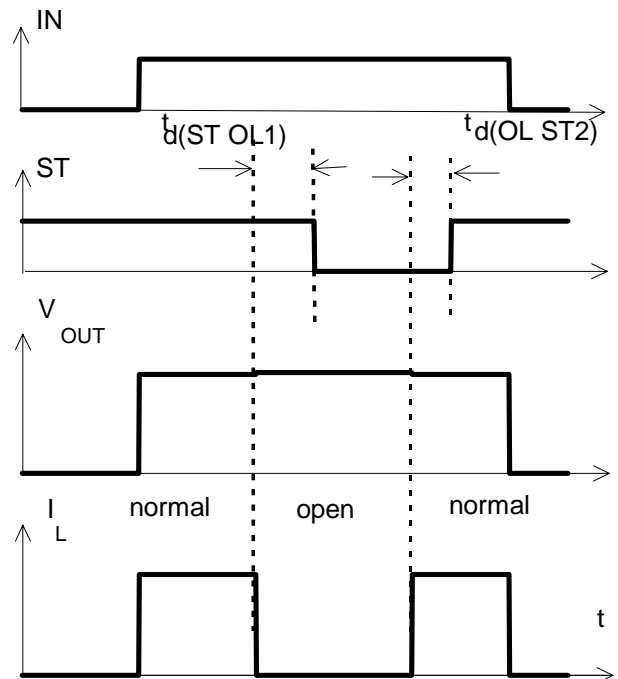

$t_d(ST OL1) = t_{bd} \mu s$ typ., $t_d(OL ST2) = t_{bd} \mu s$ typ

Figure 5b: Open load: detection in OFF-state, turn on/off to open load

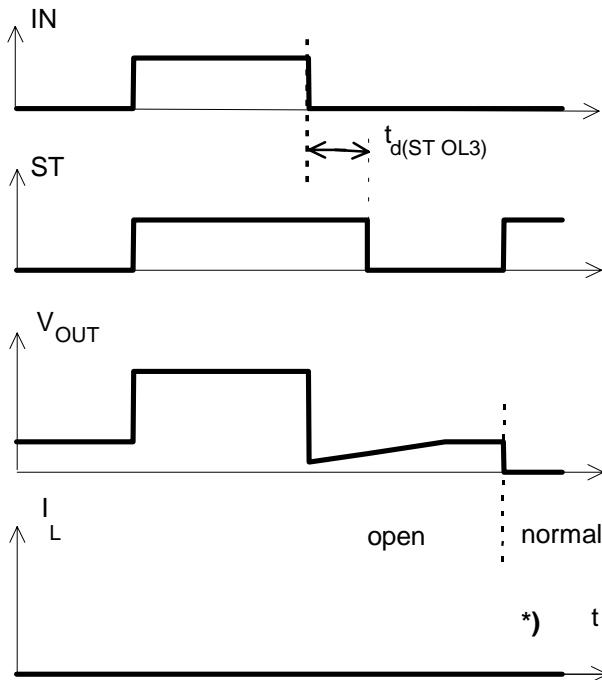

in case of external capacity $t_{d(ST,OL3)}$ may be higher due to high impedance *) $I_L = 30 \mu A$ typ

Figure 5c: Open load: detection in OFF-state, open load occurs in off-state

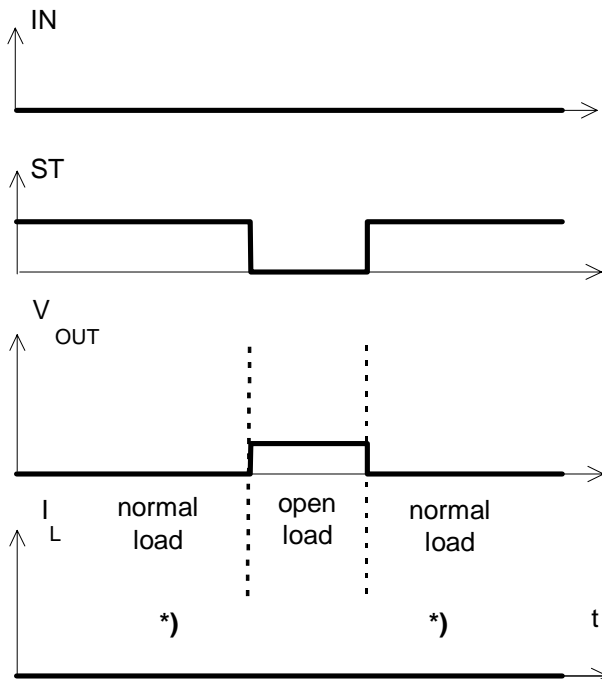

*) $I_L = 30 \mu A$ typ

Figure 6a: Undervoltage:

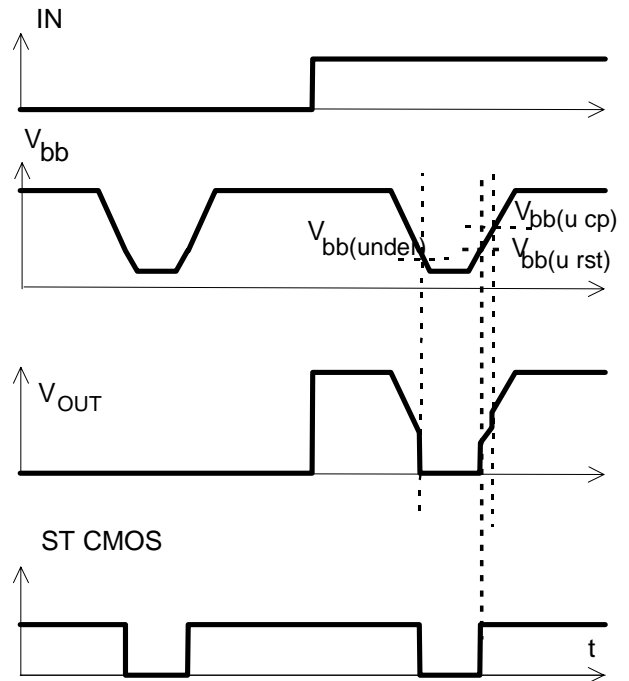

Figure 6b: Undervoltage restart of charge pump

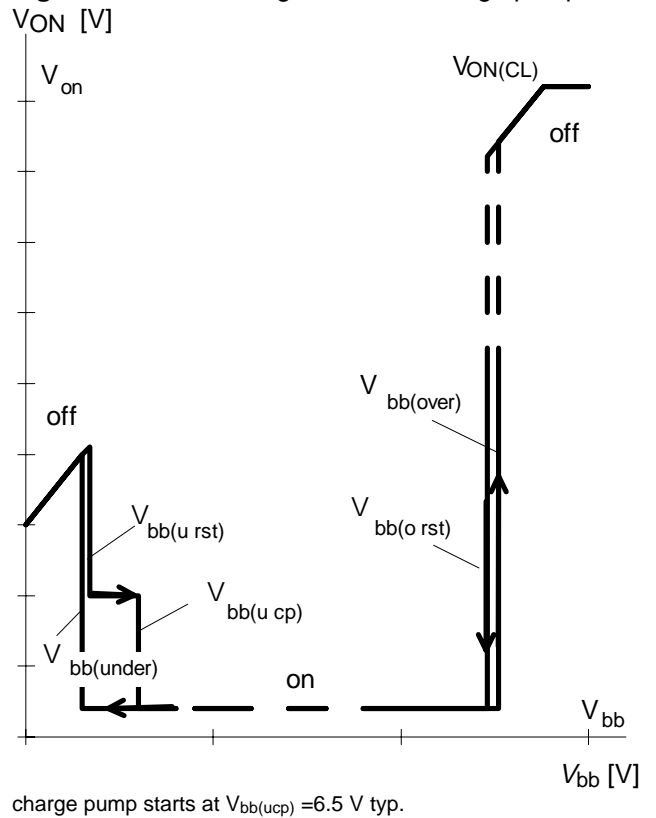
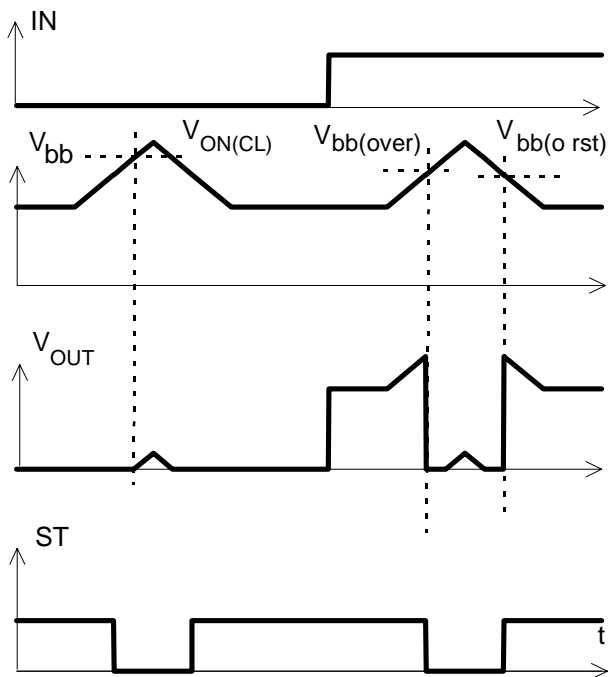

Figure 7a: Overvoltage:



Package and Ordering Code

All dimensions in mm

Standard TO-220AB/5

Ordering code

BTS 432 I2	Q67060-S6204-A2
------------	-----------------

SMD TO-220AB/5, Opt. E3122

Ordering code

BTS 432 I2 E3122A	T&R: Q67060-S6204-A3
-------------------	----------------------

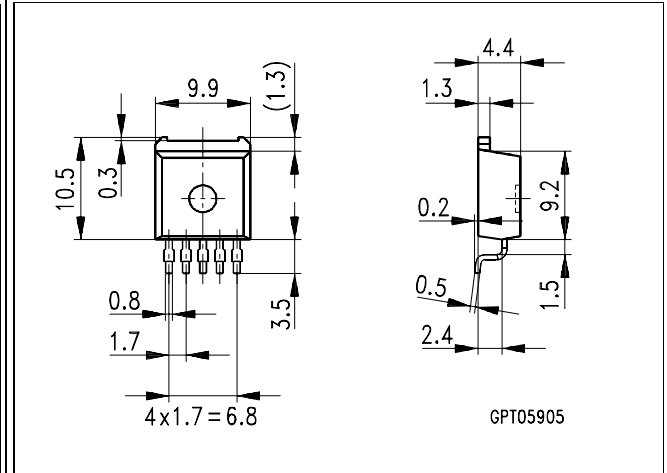
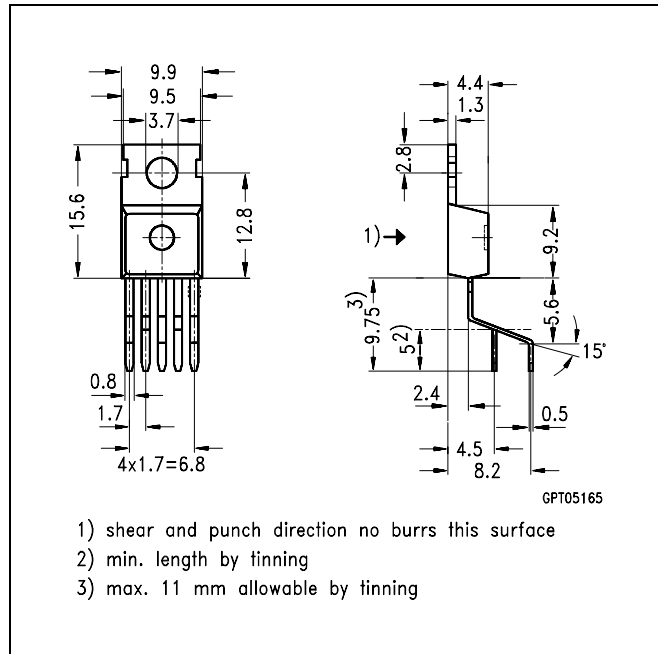

This datasheet has been download from:

www.datasheetcatalog.com

Datasheets for electronics components.