

# PBL 3770A High Performance Stepper Motor Drive Circuit

## Description

PBL 3770A is a bipolar monolithic circuit intended to control and drive the current in one winding of a stepper motor. It is a high power version of PBL 3717 and special care has been taken to optimize the power handling capability without suffering in reliability.

The circuit consists of a LS-TTL compatible logic input stage, a current sensor, a monostable multivibrator and a high power H-bridge output stage. The circuit is pin-compatible with the PBL 3717 industry-standard driver.

Two PBL 3770A and a small number of external components form a complete control and drive unit for LS-TTL or microprocessor-controlled stepper motor systems.

## Key Features

- Half-step and full-step operation.
- Switched mode bipolar constant current drive
- Wide range of current control 5 - 1800 mA.
- Wide voltage range 10 - 45 V.
- Designed for unstabilized motor supply voltage.
- Current levels can be selected in steps or varied continuously.
- Thermal overload protection.

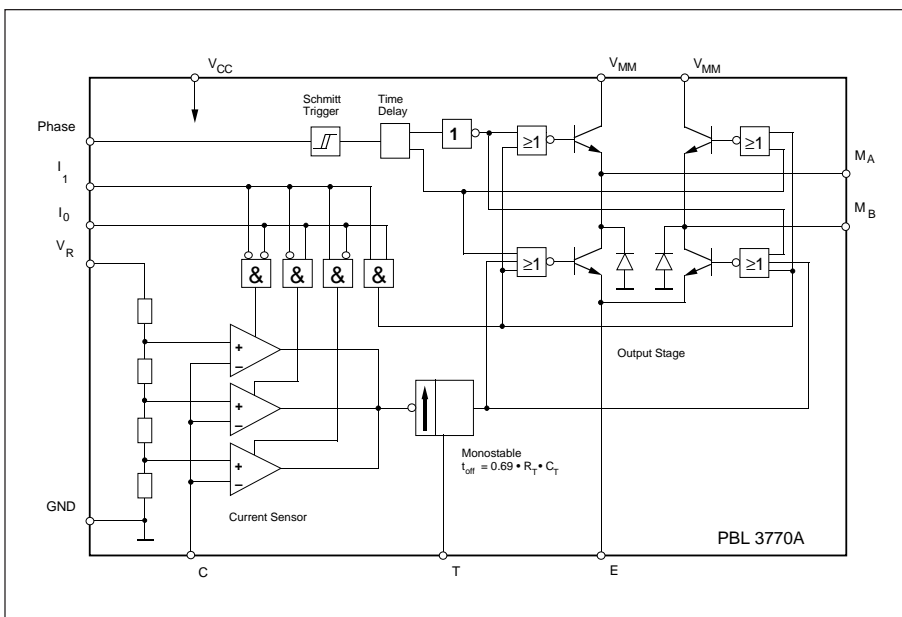
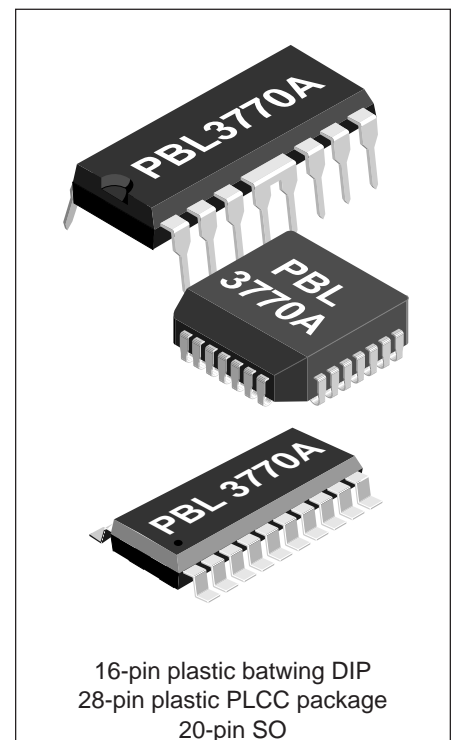

Figure 1. Block diagram.



### Maximum Ratings

Parameter	Pin no. [DIL package]	Symbol	Min	Max	Unit
<b>Voltage</b>					
Logic supply	6	$V_{CC}$	0	7	V
Motor supply	3, 14	$V_{MM}$	0	45	V
Logic inputs	7,8,9	$V_I$	-0.3	6	V
Comparator input	10	$V_C$	-0.3	$V_{CC}$	V
Reference input	11	$V_R$	-0.3	15	V
<b>Current</b>					
Motor output current	1, 15	$I_M$	-1800	+1800	mA
Logic inputs	7,8,9	$I_I$	-10		mA
Analog inputs	10,11	$I_A$	-10		mA
<b>Temperature</b>					
Operating junction temperature		$T_J$	-40	+150	°C
Storage temperature		$T_S$	-55	+150	°C

### Recommended Operating Conditions

Parameter	Symbol	Min	Typ	Max	Unit
Logic supply voltage	$V_{CC}$	4.75	5	5.25	V
Motor supply voltage	$V_{MM}$	10		40	V
Motor output current	$I_M$	-1500		+1500	mA
Junction temperature	$T_J$	-20		+125	°C
Rise time logic inputs	$t_r$			2	µs
Fall time logic inputs	$t_f$			2	µs

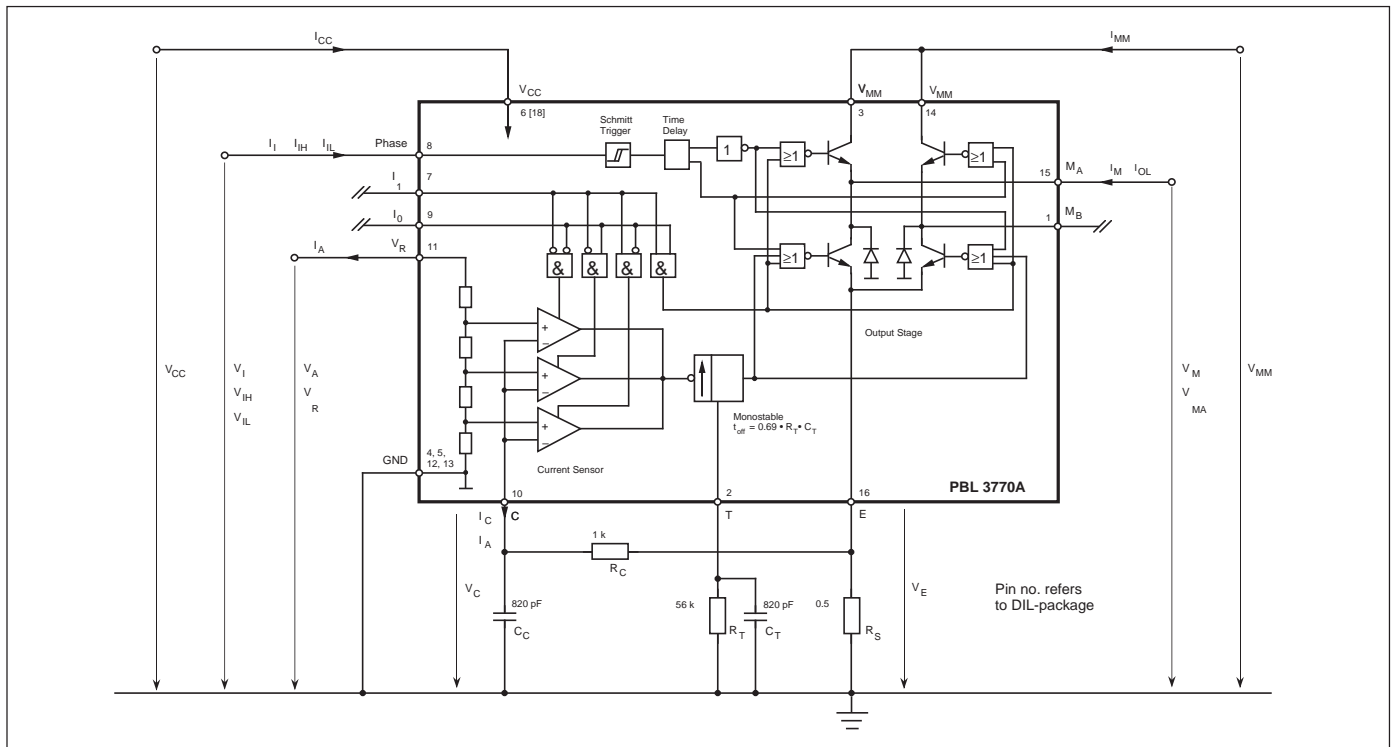

Figure 2. Definition of symbols.

## Electrical Characteristics

Electrical characteristics over recommended operating conditions.  $C_T = 820 \text{ pF}$ ,  $R_T = 56 \text{ kohm}$ .

Parameter	Symbol	Ref. fig.	Conditions	Min	Typ	Max	Unit
<b>General</b>							
Supply current	$I_{CC}$	2	$V_{MM} = 20 \text{ to } 40 \text{ V}$ , $I_0 = I_1 = \text{HIGH}$ .		30	40	mA
			$V_{MM} = 20 \text{ to } 40 \text{ V}$ , $I_0 = I_1 = \text{LOW}$ , $f_s = 23 \text{ kHz}$		48	65	mA
Total power dissipation	$P_D$		$f_s = 28 \text{ kHz}$ , $I_M = 1000 \text{ mA}$ , $V_{MM} = 36 \text{ V}$ Note 2, 4.		1.9	2.3	W
			$f_s = 24 \text{ kHz}$ , $I_M = 1000 \text{ mA}$ , $V_{MM} = 12 \text{ V}$ Note 2, 4.		1.7	2.1	W
			$f_s = 28 \text{ kHz}$ , $I_M = 1300 \text{ mA}$ , $V_{MM} = 36 \text{ V}$ Note 3, 4.		2.7	3.2	W
			$f_s = 28 \text{ kHz}$ , $I_M = 1500 \text{ mA}$ , $V_{MM} = 36 \text{ V}$ Note 3, 4.		3.5		W
Turn-off delay	$t_d$	3	$T_a = +25^\circ\text{C}$ , $dV_c/dt \geq 50 \text{ mV}/\mu\text{s}$ .			2.5	$\mu\text{s}$
Thermal shutdown junction temperature					170		$^\circ\text{C}$
<b>Logic Inputs</b>							
Logic HIGH input voltage	$V_{IH}$	2		2.0			V
Logic LOW input voltage	$V_{IL}$	2				0.8	V
Logic HIGH input current	$I_{IH}$	2	$V_I = 2.4 \text{ V}$			20	$\mu\text{A}$
Logic LOW input current	$I_{IL}$	2	$V_I = 0.4 \text{ V}$	-0.4			mA
<b>Analog Inputs</b>							
Comparator threshold voltage	$V_{CH}$	2	$V_R = 5.0 \text{ V}$ , $I_0 = I_1 = \text{LOW}$	400	415	430	mV
Comparator threshold voltage	$V_{CM}$	2	$V_R = 5.0 \text{ V}$ , $I_0 = \text{HIGH}$ , $I_1 = \text{LOW}$	240	250	265	mV
Comparator threshold voltage	$V_{CL}$	2	$V_R = 5.0 \text{ V}$ , $I_0 = \text{LOW}$ , $I_1 = \text{HIGH}$	70	80	90	mV
Input current	$I_C$	2		-20			$\mu\text{A}$
<b>Motor Outputs</b>							
Lower transistor saturation voltage			$I_M = 1000 \text{ mA}$		0.5	0.8	V
			$I_M = 1300 \text{ mA}$		0.8	1.3	V
Lower diode forward voltage drop			$I_M = 1000 \text{ mA}$		1.3	1.6	V
			$I_M = 1300 \text{ mA}$		1.5	1.8	V
Upper transistor saturation voltage			$I_M = 1000 \text{ mA}$		1.1	1.3	V
			$I_M = 1300 \text{ mA}$		1.3	1.6	V
Output leakage current			$I_0 = I_1 = \text{HIGH}$ , $T_a = +25^\circ\text{C}$			100	$\mu\text{A}$
<b>Monostable</b>							
Cut off time	$t_{off}$	3	$V_{MM} = 10 \text{ V}$ , $t_{on} \geq 5 \mu\text{s}$	27	31	35	$\mu\text{s}$

## Thermal Characteristics

Parameter	Symbol	Ref. Fig.	Conditions	Min	Typ	Max	Unit
Thermal resistance	$R_{th_{J-C}}$		DIL package.		11		$^\circ\text{C}/\text{W}$
	$R_{th_{J-A}}$	15	DIL package. Note 2.		40		$^\circ\text{C}/\text{W}$
	$R_{th_{J-C}}$		PLCC package.		9		$^\circ\text{C}/\text{W}$
	$R_{th_{J-A}}$	15	PLCC package. Note 2.		35		$^\circ\text{C}/\text{W}$
	$R_{th_{J-C}}$		SO package.		11		$^\circ\text{C}/\text{W}$
	$R_{th_{J-A}}$	15	SO package.		40		$^\circ\text{C}/\text{W}$

### Notes

- All voltages are with respect to ground. Currents are positive into, negative out of specified terminal.
- All ground pins soldered onto a  $20 \text{ cm}^2$  PCB copper area with free air convection.  $T_a = +25^\circ\text{C}$ .
- DIP package with external heatsink (Staver V7) and minimal copper area. Typical  $R_{th_{J-A}} = 27.5^\circ\text{C}/\text{W}$ .  $T_a = +25^\circ\text{C}$ .
- Not covered by final test program.

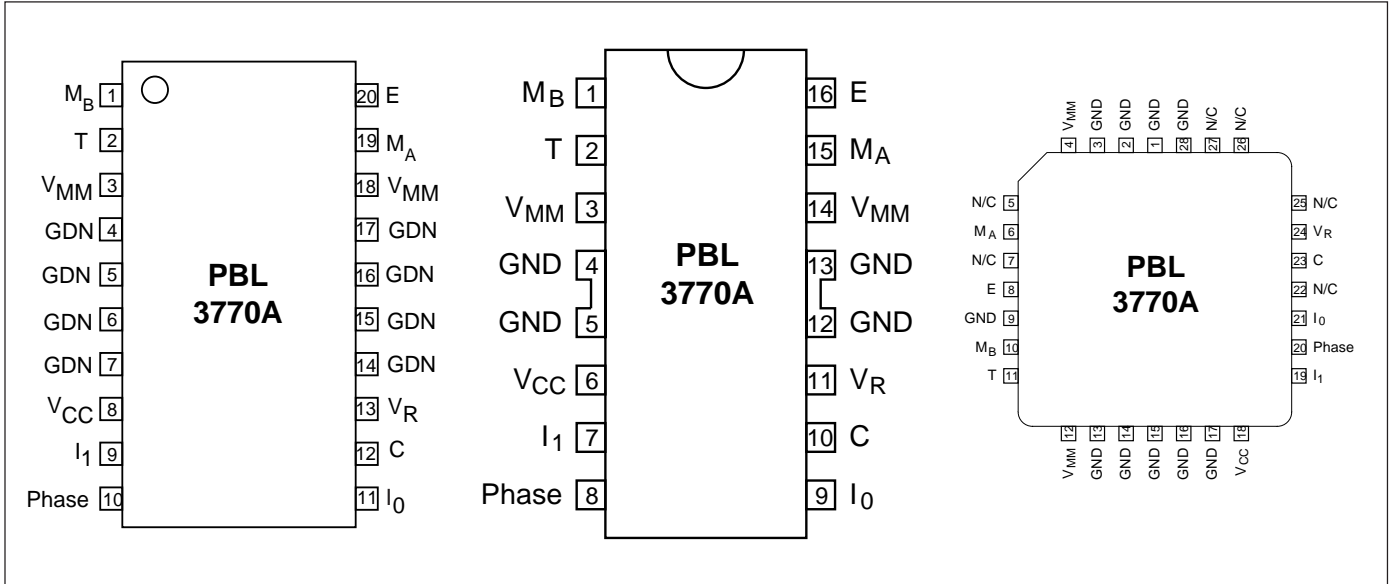

Figure 3. Pin configurations.

**Pin Description**

SO	DIP	PLCC	Symbol	Description
1	1	10	M <sub>B</sub>	Motor output B, Motor current flows from M <sub>A</sub> to M <sub>B</sub> when Phase is high.
2	2	11	T	Clock oscillator. Timing pin connect a 56 kΩ resistor and a 820 pF in parallel between T and Ground.
3	3,14	12,4	V <sub>MM</sub>	Motor supply voltage, 10 to 40 V. Pin 3(12) and pin 14(4) should be wired together.
4-7, 14-18	4,5, 12,13	1-3,9, 13-17,28	GND	Ground and negative supply. Note these pins are used for heatsinking. Make sure that all ground pins are soldered onto a suitable large copper ground plane for efficient heat sinking.
8	6	18	V <sub>CC</sub>	Logic voltage supply normally +5 V.
9	7	19	I <sub>1</sub>	Logic input. It controls, together with the I0 input, the current level in the output stage. The controlable levels are fixed to 100, 60, 20, 0%.
10	8	20	Phase	Controls the direction of the motor current of M <sub>A</sub> and M <sub>B</sub> outputs. Motor current flows from M <sub>A</sub> to M <sub>B</sub> when the phase input is high.
11	9	21	I <sub>0</sub>	Logic input. It controls, together with the I1 input, the current level in the output stage. The controlable levels are fixed to 100, 60, 20, 0%.
12	10	23	C	Comparator input. This input senses the instaneous voltage across the sensing resistor, filtered through a RC Network.
13	11	24	V <sub>R</sub>	Reference voltage. Controls the threshold voltage of the comparator and hence the output current. Input resistance: typically 6.8 kΩ ± 20%.
19	15	6	M <sub>A</sub>	Motor output A, Motor current flows from M <sub>A</sub> to M <sub>B</sub> when Phase is high.
20	16	8	E	Common emitter. Connect the Sence resistor between this pin and ground.

**Functional Description**

The PBL 3770A is intended to drive a bipolar constant current through one winding of a 2-phase stepper motor.

Current control is achieved through switched-mode regulation, see figure 5 and 6.

Three different current levels and zero current can be selected by the input logic.

The circuit contains the following functional blocks:

- Input logic
- Current sense
- Single-pulse generator
- Output stage

**Input logic**

**Phase input.** The phase input determines the direction of the current in the motor winding. High input forces the current from terminal  $M_A$  to  $M_B$  and low input from terminal  $M_B$  to  $M_A$ . A Schmitt trigger provides noise immunity and a delay circuit eliminates the risk of cross conduction in the output stage during a phase shift.

Half- and full-step operation is possible.

**Current level selection.** The status of  $I_0$  and  $I_1$  inputs determines the current level in the motor winding. Three fixed current levels can be selected according to the table below.

Motor current		$I_0$	$I_1$
High level	100%	L	L
Medium level	60%	H	L
Low level	20%	L	H
Zero current	0%	H	H

The specific values of the different current levels are determined by the reference voltage  $V_R$  together with the value of the sensing resistor  $R_S$ .

The peak motor current can be calculated as follows:

$$i_m = (V_R \cdot 0.080) / R_S [A], \text{ at 100\% level}$$

The motor current can also be continuously varied by modulating the voltage reference input.

**Current sensor**

The current sensor contains a reference voltage divider and three comparators for measuring each of the selectable current levels. The motor current is

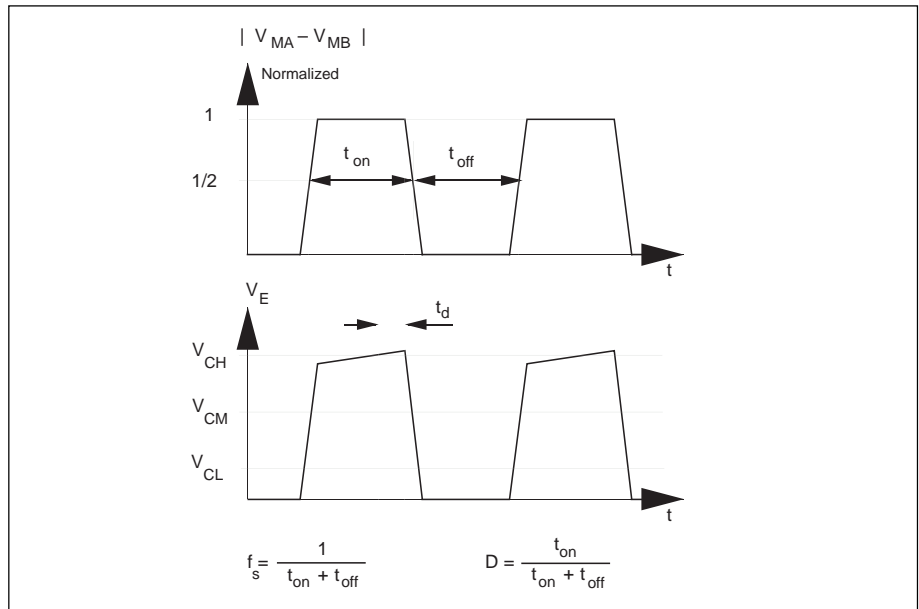

Figure 4. Definition of terms.

sensed as a voltage drop across the current sensing resistor,  $R_S$ , and compared with one of the voltage references from the divider. When the two voltages are equal, the comparator triggers the single-pulse generator. Only one comparator at a time is activated by the input logic.

**Single-pulse generator**

The pulse generator is a monostable multivibrator triggered on the positive edge of the comparator output. The multivibrator output is high during the pulse time,  $t_{off}$ , which is determined by the timing components  $R_T$  and  $C_T$ .

$$t_{off} = 0.69 \cdot R_T \cdot C_T$$

The single pulse switches off the power feed to the motor winding, causing the winding to decrease during  $t_{off}$ .

If a new trigger signal should occur during  $t_{off}$ , it is ignored.

**Output stage**

The output stage contains four transistors and two diodes, connected in an H-bridge. Note that the upper recirculation diodes are connected to the circuit externally. The two sinking transistors are used to switch the power supplied to the motor winding, thus driving a constant current through the winding. See figures 5 and 6.

**Overload protection**

The circuit is equipped with a thermal shut-down function, which will limit the junction temperature. The output current will be reduced if the maximum permissible junction temperature is exceeded. It should be noted, however, that it is not short circuit protected.

**Operation**

When a voltage  $V_{MM}$  is applied across the motor winding, the current rise follows the equation:

$$i_m = (V_{MM} / R) \cdot (1 - e^{-(R \cdot t) / L})$$

$R$  = Winding resistance

$L$  = Winding inductance

$t$  = time

(see figure 6, arrow 1)

The motor current appears across the external sensing resistor,  $R_S$ , as an analog voltage. This voltage is fed through a low-pass filter,  $R_C C_C$ , to the voltage comparator input (pin 10). At the moment the sensed voltage rises above the comparator threshold voltage, the monostable is triggered and its output turns off the conducting sink transistor.

The polarity across the motor winding reverses and the current is forced to circulate through the appropriate upper protection diode back through the source transistor (see figure 6, arrow 2).

After the monostable has timed out, the current has decayed and the analog

voltage across the sensing resistor is below the comparator threshold level.

The sinking transistor then turns on and the motor current starts to increase again. The cycle is repeated until the current is turned off via the logic inputs.

When both  $I_1$  and  $I_0$  are high, all four transistors in the output H-bridge are turned off, which means that inductive current recirculates through two opposite free-wheeling diodes (see figure 6, arrow 3). this method of turning off the current results in a faster current decay than if only one transistor was turned off and will therefore improve speed performance in half-stepping mode.

**Heatsinking**

The junction temperature of the chip highly effects the lifetime of the circuit. In high-current applications, the heatsinking must be carefully considered.

The  $R_{th_{j-a}}$  of the PBL 3770A can be reduced by soldering the ground pins to a suitable copper ground plane on the printed circuit board (see figure 14) or by applying an external heatsink type V7 or V8, see figure 14.

The diagram in figure 13 shows the maximum permissible power dissipation versus the ambient temperature in °C, for heatsinks of the type V7, V8, or a 20 cm<sup>2</sup> copper area respectively. Any external heatsink or printed circuit board copper must be connected to electrical ground.

For motor currents higher than approx 600 mA, some form of heatsinking is recommended to assure optimal reliability.

The diagrams in figures 12 and 13 can be used to determine the required heatsinking of the circuit. In some systems, forced-air cooling may be available to reduce the temperature rise of the circuit.

**Applications Information**

**Motor selection**

Some stepper motors are not designed for continuous operation at maximum current. As the circuit drives a constant current through the motor, its temperature can increase, both at low- and high-speed operation.

Some stepper motors have such high core losses that they are not suited for switched-mode operation.

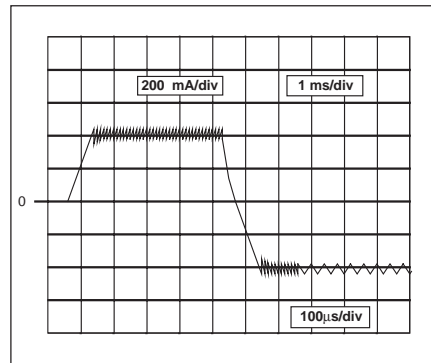

Figure 5. Motor current ( $I_M$ ), Vertical : 200 mA/div, Horizontal: 1 ms/div, expanded part 100 μs/div.

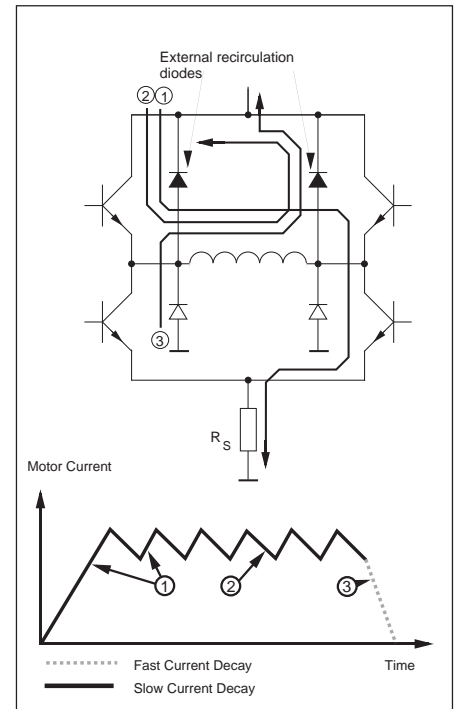

Figure 6. Output stage with current paths for fast and slow current decay.

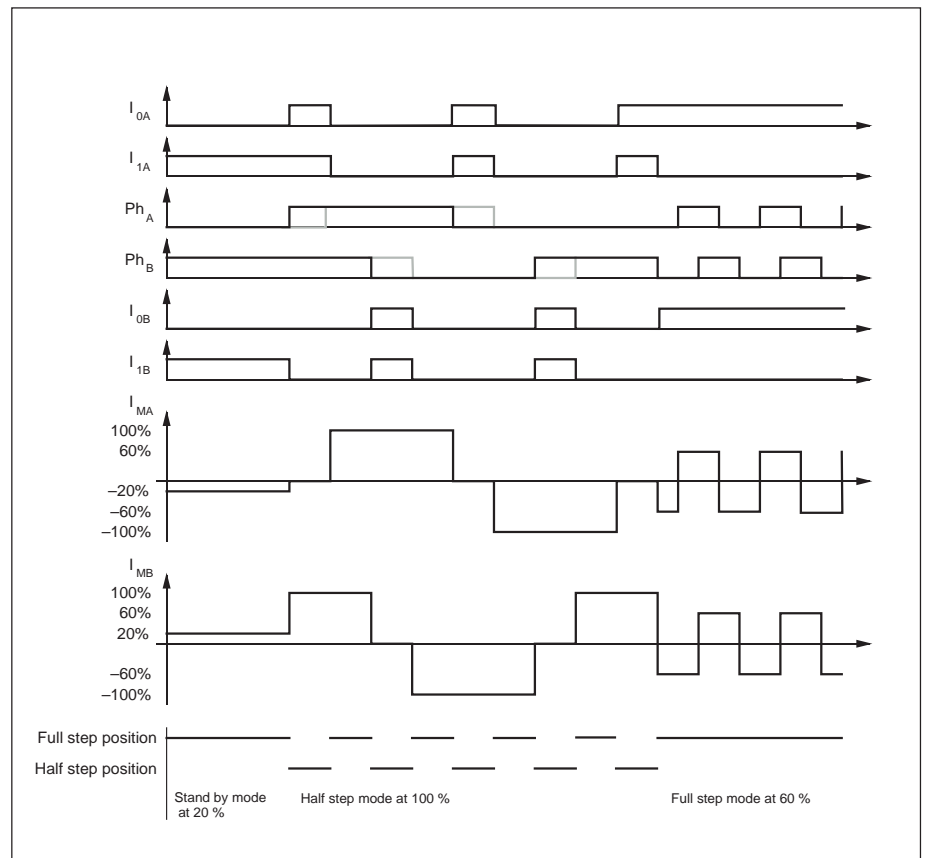

Figure 7. Principal operating sequence.



**Sensor resistor**

The  $R_S$  resistor should be of a non-inductive type power resistor. A 0.5 ohm resistor, tolerance  $\leq 1\%$ , is a good choice for 800 mA max motor current at  $V_R = 5V$ .

The peak motor current,  $i_m$ , can be calculated by using the formula:

$$i_m = (V_R \cdot 0.080) / R_S [A], \text{ at 100\% level}$$

**External recirculation diodes**

Recirculation diodes must be connected across each motor terminal and the supply voltage,  $V_{MM}$ . The anodes shall be connected to the motor terminals and the cathodes to the  $V_{MM}$  voltage. Ultra-fast recovery diodes should be used for maximum performance and reliability.

**Ordering Information**

Package	Part No.
DIP Tube	PBL 3770ANS
PLCC Tube	PBL 3770AQNS
PLCC Tape & Reel	PBL 3770AQNT
SO Tube	PBL 3770ASOS
SO Tape & Reel	PBL 3770ASOT

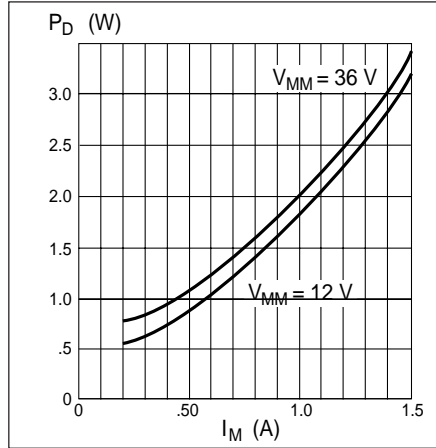

Figure 12. Typical power dissipation vs. motor current.

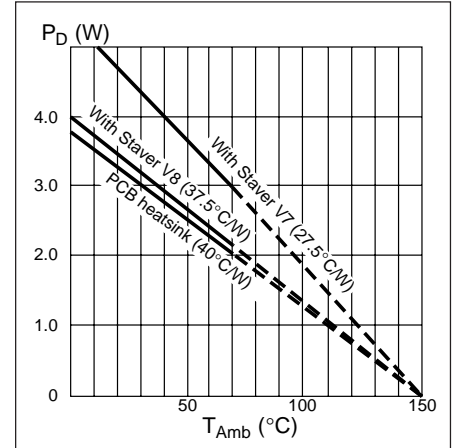

Figure 13. Allowable power dissipation vs. ambient temperature.

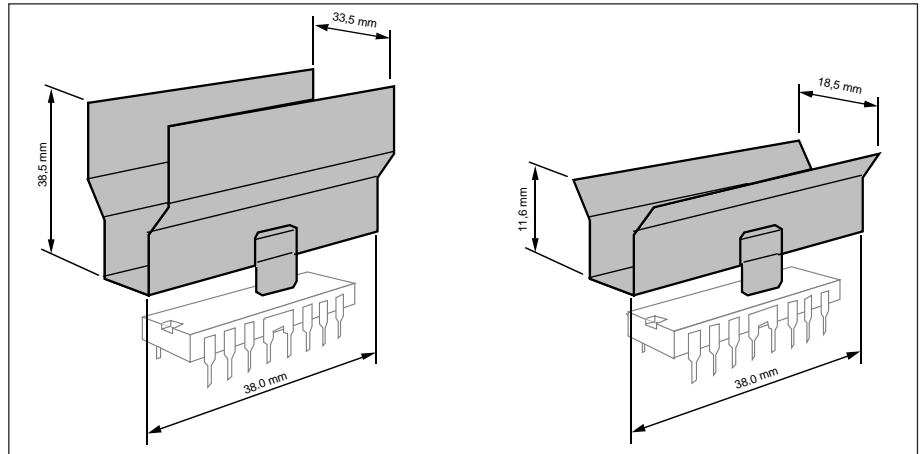

Figure 14. Heatsinks, Staver, type V7 and V8 by Columbia-Staver UK.

Information given in this data sheet is believed to be accurate and reliable. However no responsibility is assumed for the consequences of its use nor for any infringement of patents or other rights of third parties which may result from its use. No license is granted by implication or otherwise under any patent or patent rights of Ericsson Components AB. These products are sold only according to Ericsson Components' general conditions of sale, unless otherwise confirmed in writing.

Specifications subject to change without notice.

1522-PBL 3770/6Uen. Rev E  
© Ericsson Components AB 1999

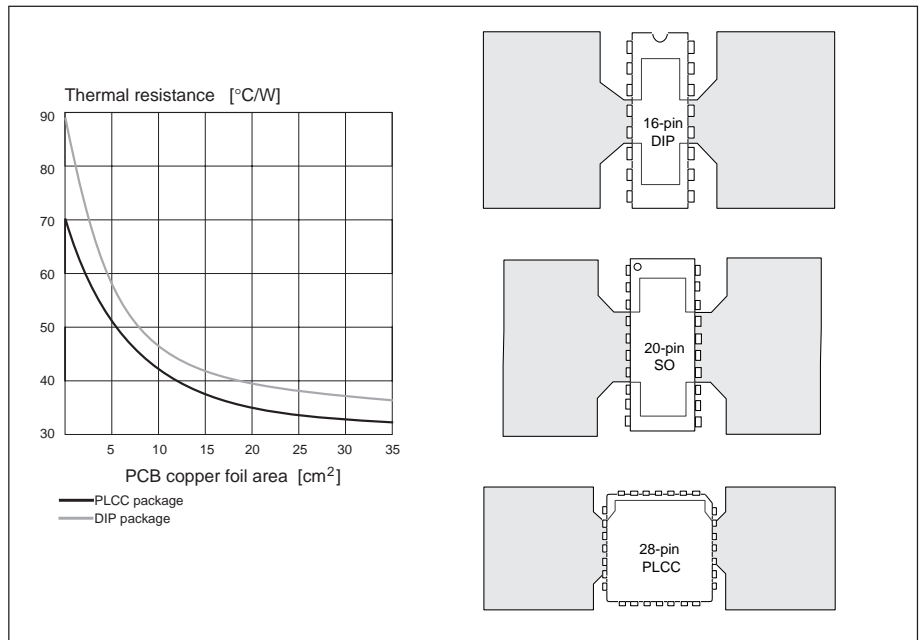

Figure 15. Copper foil used as a heatsink.



This datasheet has been downloaded from:

[www.DatasheetCatalog.com](http://www.DatasheetCatalog.com)

Datasheets for electronic components.