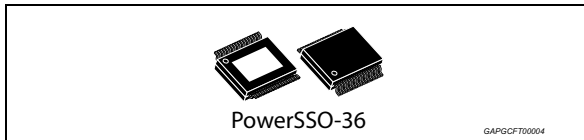


## H-bridge motor driver for automotive DC motor driving

Datasheet - production data



### Features

Type	$R_{DS(on)}$	$I_{out}$	$V_{CCmax}$
VNHD7012AY	12 mΩ typ (per channel)	38 A	38 V

- AEC-Q100 qualified
- Output current: 38 A
- Dual fully protected HSD with MultiSense feedback
- Two integrated drivers for the external LSDs
- 3 V CMOS compatible inputs
- Protections:
  - Undervoltage shutdown
  - Overvoltage clamp
  - Thermal shutdown
  - Load current limitation
  - Self-limiting of fast thermal transients (Power Limitation)
  - Cross current protection
  - Shoot through protection
  - Loss of ground and loss of  $V_{CC}$
  - Electrostatic discharge protection
  - Drain and source voltage monitoring of the external power MOSFETs, configurable via an external resistance (short-to-battery protection)
- PWM operation up to 20 kHz for external LSDs
- MultiSense monitoring functions
  - Analog motor current feedback
  - Chip temperature monitoring
  - Battery voltage monitoring



- MultiSense diagnostic functions
  - Output short to ground detection
  - Thermal shutdown indication
  - OFF-state open-load detection
  - Output short to  $V_{CC}$  detection
- Standby mode
- Half bridge operation
- Charge pump output for reverse battery protection
- Package: ECOPACK®

### Description

The device is a DC motor driver for automotive applications. It integrates a full protected dual high-side driver and the drivers and protections for the two external power MOSFETs in low-side configuration.

The device is designed using STMicroelectronics' well known and proven proprietary VIPower® technology that allows to efficiently integrate on the same die a true PowerMOSFET with an intelligent signal/ protection circuitry. The device is housed in a PowerSSO-36 exposed pad package to optimize the dissipation performances.

The input signals  $IN_A$  and  $IN_B$  can directly interface the microcontroller to select the motor direction and the brake conditions. Two selection pins (SEL0 and SEL1) are available to address to the microcontroller the information available on the MultiSense. The MultiSense pin allows to monitor the motor current, provides a voltage proportional to the battery value and the information on the temperature of the chip. The integrated protections are: load current limitation, overload active power limitation (with latch-off), overtemperature shutdown (with latch-off) and cross current protection.

# Contents

- 1      Block diagram and pin description ..... 6**
- 2      Electrical specifications ..... 9**
  - 2.1 Absolute maximum ratings ..... 9
  - 2.2 Thermal data ..... 10
  - 2.3 Electrical characteristics ..... 11
  - 2.4 Waveforms ..... 24
- 3      Protections ..... 27**
  - 3.1 Power limitation (high-side driver) ..... 27
  - 3.2 Thermal shutdown ..... 27
  - 3.3 High-side current limitation ..... 27
  - 3.4 External PowerMOS low side VDS monitoring ..... 27
- 4      Typical application schematic ..... 28**
- 5      MultiSense operation ..... 29**
  - 5.1 MultiSense analog monitoring ..... 29
  - 5.2 Multisense diagnostics flag in fault conditions ..... 29
- 6      VREG and Driver\_LS Block ..... 30**
- 7      Reverse battery protection ..... 30**
- 8      Open-load detection in off-state ..... 30**
- 9      Immunity against transient electrical disturbances ..... 31**
- 10     Package and PCB thermal data ..... 32**
  - 10.1 PowerSSO-36 thermal data ..... 32
- 11     Package and packing information ..... 36**
  - 11.1 PowerSSO-36 package information ..... 36
  - 11.2 PowerSSO-36 packing information ..... 38

---

	11.3	PowerSSO-36 marking information .....	40
<b>12</b>		<b>Order codes .....</b>	<b>41</b>
<b>13</b>		<b>Revision history .....</b>	<b>42</b>

## List of tables

Table 1.	Block description . . . . .	6
Table 2.	Pin definitions and functions . . . . .	8
Table 3.	Suggested connection for unused and not connected pins . . . . .	8
Table 4.	Absolute maximum ratings . . . . .	9
Table 5.	Thermal data . . . . .	10
Table 6.	Power section . . . . .	11
Table 7.	Logic inputs ( $IN_A$ , $IN_B$ ) ( $V_{CC} = 7\text{ V up to } 28\text{ V; } -40\text{ }^\circ\text{C} < T_j < 150\text{ }^\circ\text{C}$ ) . . . . .	12
Table 8.	HSD switching ( $V_{CC} = 13\text{ V; } R_{LOAD} = 1.6\ \Omega$ ) . . . . .	13
Table 9.	Gate driver for external MOS parameters ( $V_{CC} = 13\text{ V}$ ) . . . . .	13
Table 10.	Protections and diagnostics ( $7\text{ V} < V_{CC} < 18\text{ V; } -40\text{ }^\circ\text{C} < T_j < 150\text{ }^\circ\text{C}$ ). . . . .	13
Table 11.	MultiSense ( $7\text{ V} < V_{CC} < 18\text{ V; } -40\text{ }^\circ\text{C} < T_j < 150\text{ }^\circ\text{C}$ ) . . . . .	15
Table 12.	Operative condition - truth table . . . . .	22
Table 13.	On-state fault conditions- truth table . . . . .	22
Table 14.	Off-state — truth table . . . . .	23
Table 15.	IISO 7637-2 - electrical transient conduction along supply line . . . . .	31
Table 16.	PCB properties . . . . .	33
Table 17.	Thermal parameters . . . . .	34
Table 18.	PowerSSO-36 (exposed pad) package mechanical data . . . . .	36
Table 19.	Device summary . . . . .	41
Table 20.	Document revision history . . . . .	42

## List of figures

Figure 1.	Block diagram . . . . .	6
Figure 2.	Configuration diagram (top view) . . . . .	7
Figure 3.	Current and voltage conventions . . . . .	9
Figure 4.	$T_{DSTKON}$ . . . . .	18
Figure 5.	Definition of the low-side switching times . . . . .	19
Figure 6.	Definition of the high-side switching times . . . . .	19
Figure 7.	Low-side turn-on delay time . . . . .	20
Figure 8.	Input reset time for HSD-fault unlatch . . . . .	20
Figure 9.	Input reset time for LSD-fault unlatch . . . . .	21
Figure 10.	OFF-state diagnostic delay time from rising edge of VOUT ( $t_{D\_VOL}$ ) . . . . .	21
Figure 11.	Normal operative conditions (resistive load) . . . . .	24
Figure 12.	Out shorted to ground and short clearing . . . . .	25
Figure 13.	OUT shorted to Vcc and short clearing . . . . .	26
Figure 14.	Gate driver low side rise time normalized vs $C_g = 4.7nF$ . . . . .	26
Figure 15.	Gate driver low side fall time normalized vs $C_g = 4.7nF$ . . . . .	26
Figure 16.	Typical application schematic . . . . .	28
Figure 17.	MultiSense block diagram . . . . .	29
Figure 18.	PowerSSO-36 PCB board . . . . .	32
Figure 19.	$R_{thj-amb}$ vs PCB copper area in open box free air condition . . . . .	33
Figure 20.	Thermal fitting model of a double-channel HSD in PowerSSO-36 . . . . .	34
Figure 21.	Thermal impedance junction ambient single pulse . . . . .	34
Figure 22.	PowerSSO-36 package dimensions . . . . .	36
Figure 23.	PowerSSO-36 tube shipment (no suffix) . . . . .	38
Figure 24.	PowerSSO-36 tape and reel shipment (suffix "TR") . . . . .	39
Figure 25.	PowerSSO-36 marking information . . . . .	40

# 1 Block diagram and pin description

Figure 1. Block diagram

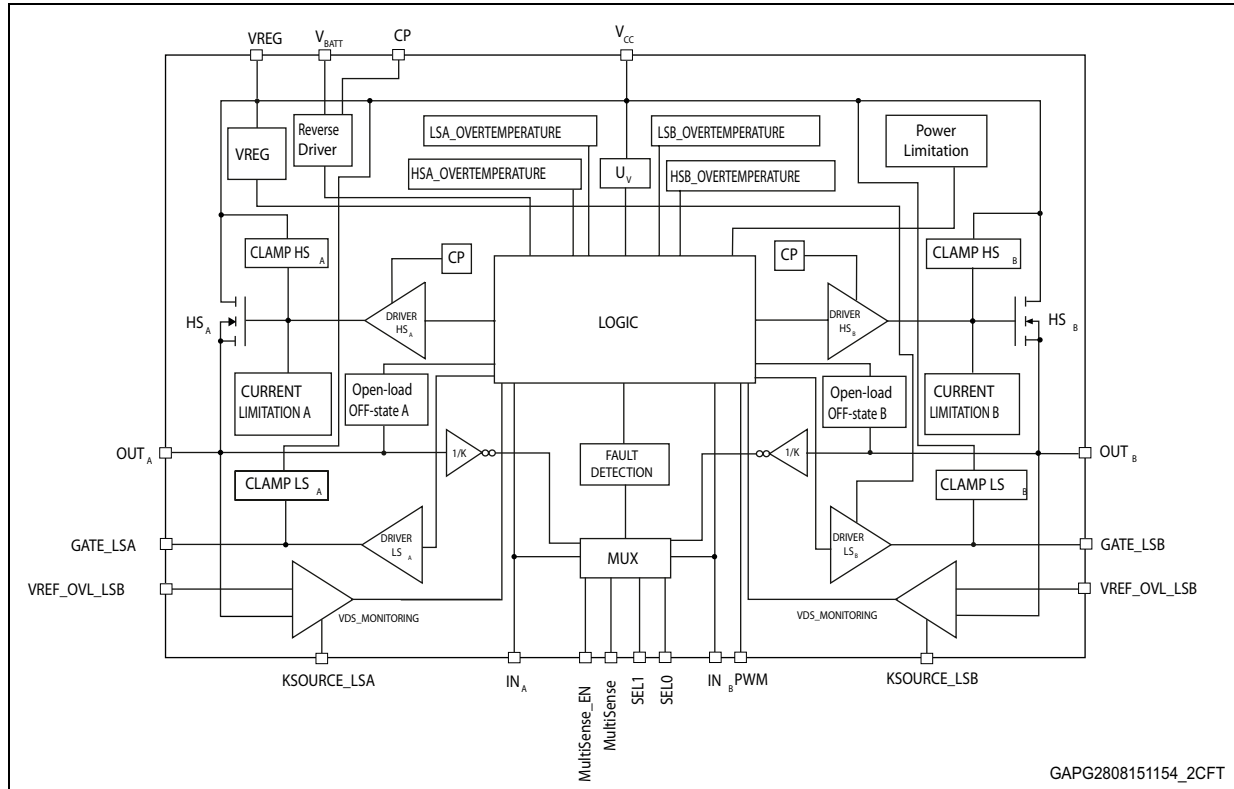


Table 1. Block description

Name	Description
Logic control	Allows the turn-on and the turn-off of the high-side and the low-side switches according to the truth table.
Undervoltage (U <sub>S</sub> )	Shuts down the device for battery voltage below (4 V).
High-side and low-side clamp voltage	Protect the high-side and the low-side switches from the high voltage on the battery line.
High-side and low-side driver	Drive the gate of the concerned switch to allow a proper R <sub>On</sub> for the leg of the bridge.
Current limitation	Limits the motor current in case of short circuit.
High-side overtemperature protection	In case of short-circuit with the increase of the junction temperature, it shuts down the concerned driver to prevent degradation and to protect the die.
VDS_MONITORING	Protection of LSD powers against short to battery failure
VREG	Internal voltage regulator that provides the supply for the gates of the external low-side switches
Fault detection	Signals an abnormal condition of the power stage (output shorted to ground or output shorted to battery) by a feedback on the MultiSense

Table 1. Block description (continued)

Name	Description
Power limitation	Limits the power dissipation of the high-side driver inside safe range in case of short to ground condition.
Open-load in OFF-state	Signalize, in combination with an external resistor, an open-load when the switches are off by a feedback on the MultiSense
T <sub>chip</sub> monitoring	Provides a signal linked to the Chip temperature by a feedback on the MultiSense
V <sub>CC</sub> monitoring	Provides a signal linked to the Chip temperature by a feedback on the MultiSense
Reverse driver	Drives an external PowerMOSFET to provide the reverse battery protection
CP	Charge pump to drive the external N-MOSFET used on the battery track for the reverse battery protection. The N-MOSFET source must be connected to the V <sub>batt</sub> pin.

Figure 2. Configuration diagram (top view)

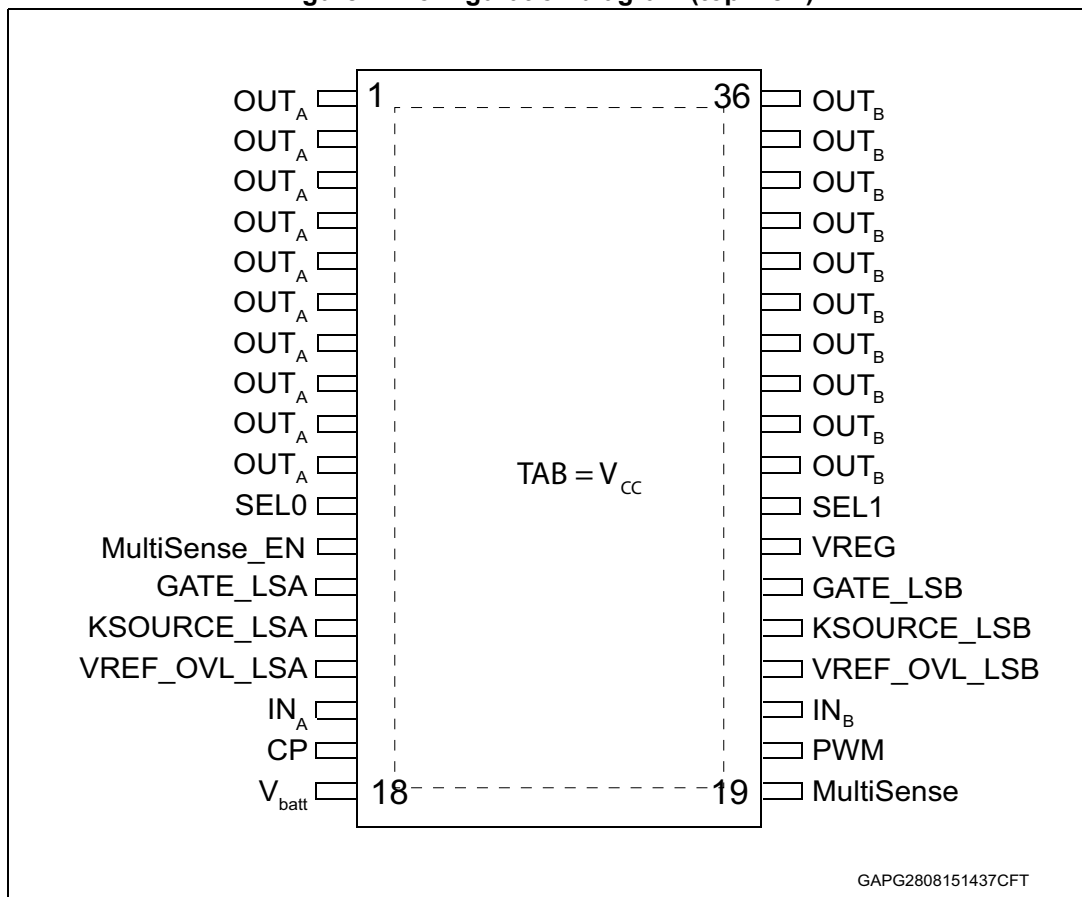


Table 2. Pin definitions and functions

Pin N°	Symbol	Function
20	PWM	PWM input.
25	VREG	Internal supply output
16	IN <sub>A</sub>	Clockwise input.
18	V <sub>batt</sub>	Battery supply, connection to the source of the external PowerMOS used for the reverse battery protection
19	MultiSense	Output of current sense and diagnostic feedback
12	MultiSense_EN	Enables the MultiSense diagnostic pin
11	SEL0	Address the MultiSense multiplexer (refer to <a href="#">Table 12</a> )
26	SEL1	Address the MultiSense multiplexer (refer to <a href="#">Table 12</a> )
21	IN <sub>B</sub>	Counter clockwise input.
1, 2, 3, 4, 5, 6, 7, 8, 9, 10	OUT <sub>A</sub>	Source of high-side switch A
27, 28, 29, 30, 31, 32, 33, 34, 35, 36	OUT <sub>B</sub>	Source of high-side switch B
17	CP	Drives the gate of external P-MOSFET for the reverse battery protection
15	VREF_OVL_LSA	Sets the threshold for VDS_MONITORING feature for LSA
22	VREF_OVL_LSB	Sets the threshold for VDS_MONITORING feature for LSB
13	GATE_LSA	Gate driver of the external PowerMOS LSA
24	GATE_LSB	Gate driver of the external PowerMOS LSB
14	KSOURCE_LSA	Source of external LSA. Ground connection
23	KSOURCE_LSB	Source of external LSB. Ground connection
TAB	V <sub>CC</sub>	Supply voltage. Drain of the high-side switches and connection to the drain of the external PowerMOS used for the reverse battery protection

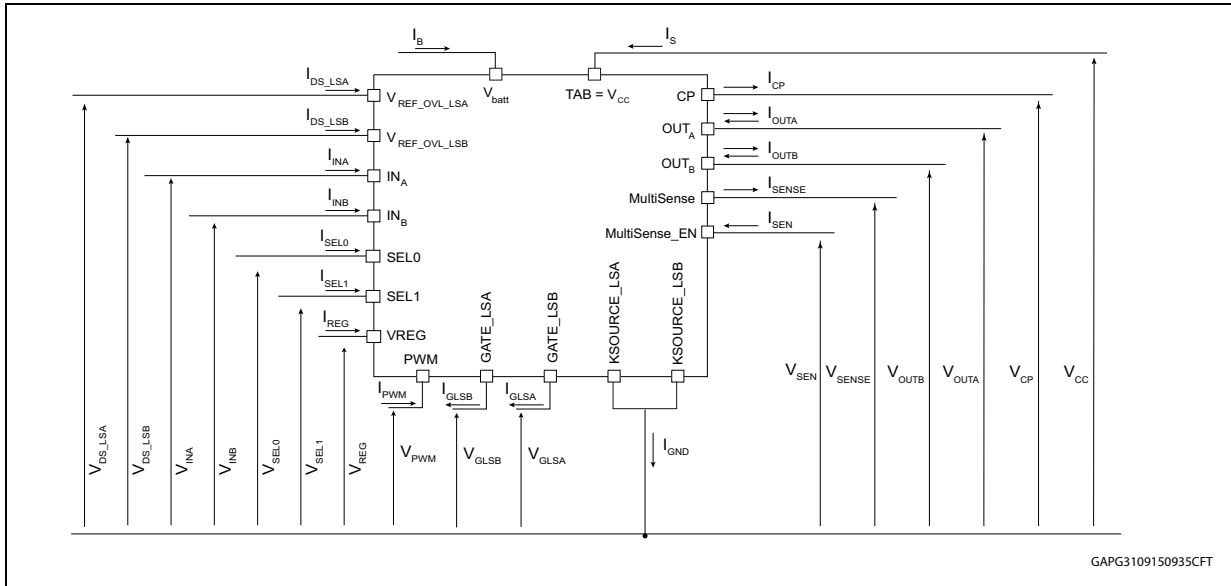
Table 3. Suggested connection for unused and not connected pins

Connection / pin	OUTA, OUTB	Inx, PWM, SELx, Multisense_EN	Multisense	GATE_LSA, GATE_LSB, CP, VREG	VREF_OVL_LSA, VREF_OVL_LSB
Floating	X	X	X	X	X
To ground	Not allowed	Through 10 kΩ resistor		Not allowed	X



## 2 Electrical specifications

Figure 3. Current and voltage conventions



### 2.1 Absolute maximum ratings

Stressing the device above the rating listed in [Table 4](#) may cause permanent damage to the device. These are stress ratings only and operation of the device at these or any other conditions above those indicated in the Operating sections of this specification is not implied. Exposure to Absolute Maximum Rating conditions for extended periods may affect device reliability.

Table 4. Absolute maximum ratings

Symbol	Parameter	Value	Unit
V <sub>CC</sub>	Bridge supply voltage	38	V
V <sub>BAT</sub>	Maximum battery voltage <sup>(1)</sup>	-16 to 38	V
I <sub>max</sub>	DC output current	Internally limited	A
I <sub>R</sub>	Reverse output current (continuous) <sup>(2)</sup>	30	A
I <sub>IN</sub>	Input current (IN <sub>A</sub> and IN <sub>B</sub> pins)	-1 to 10	mA
I <sub>SEL</sub>	SEL <sub>0,1</sub> DC input current	-1 to 10	mA
I <sub>PWM</sub>	PWM Input current	-1 to 10	mA
I <sub>MultiSense_EN</sub>	SenseEnable DC input current	-1 to 1.5	mA
I <sub>MultiSense</sub>	MultiSense pin DC output current (V <sub>GND</sub> = V <sub>CC</sub> and V <sub>SENSE</sub> < 0 V)	10	mA
	MultiSense pin DC output current in reverse (V <sub>CC</sub> < 0 V)	-20	mA
V <sub>REG</sub>	V <sub>REG</sub> DC voltage	12	V

**Table 4. Absolute maximum ratings (continued)**

Symbol	Parameter	Value	Unit
V <sub>CP</sub>	V <sub>CP</sub> DC voltage	V <sub>BATT</sub> -6 to V <sub>BAT</sub> +14	V
VGATE_LSx	GATE_LAS, GATE_LSB DC voltage	12	V
VREF_OVL_LSx	VREF_OVL_LSA, VREF_OVL_LSB input current	-1 to 10	V
V <sub>ESD</sub>	Electrostatic discharge (Human body model: R = 1.5 kΩ; C = 100 pF) – MultiSenseVREG, VREF_OVL_LSx – IN <sub>A</sub> , IN <sub>B</sub> , OUT <sub>A</sub> , OUT <sub>B</sub> , PWM, SEL0, SEL1, SENSE_EN – GATE_LSx	2 4 4	kV
T <sub>c</sub>	Junction operating temperature	-40 to 150	°C
T <sub>STG</sub>	Storage temperature	-55 to 150	°C
I <sub>K_SOURCE_LSx</sub>	DC reverse ground pin current (per leg)	100	mA

1. This applies with the n-channel MOSFET used for the reverse battery protection. Otherwise VBAT has to be shorted to V<sub>CC</sub>.
2. Based on the internal wires capability.

*Note:* All logic pins cannot be left floating but they must be connected to GND if unused.

## 2.2 Thermal data

**Table 5. Thermal data**

Symbol	Parameter	Max. value	Unit
R <sub>thj-case</sub>	Thermal resistance junction-case (per leg channel) (JEDEC JESD 51-8)	2.4	°C/W
R <sub>thj-amb</sub>	Thermal resistance junction-ambient (JEDEC JESD 51-5) <sup>(1)</sup>	50.6	°C/W
R <sub>thj-amb</sub>	Thermal resistance junction-ambient (JEDEC JESD 51-7)	16.6	°C/W

1. Device mounted on two-layers 2s0p PCB with 2 cm<sup>2</sup>.heatsink copper trace.

## 2.3 Electrical characteristics

$V_{CC} = 7\text{ V}$  up to  $28\text{ V}$ ;  $-40\text{ °C} < T_j < 150\text{ °C}$ , unless otherwise specified.

**Table 6. Power section**

Symbol	Parameter	Test conditions	Min.	Typ.	Max.	Unit
$V_{CC}$	Operating supply voltage		4		28	V
$I_S$	Supply current	Off-state standby $I_{N_A} = I_{N_B} = PWM = \text{Multisense\_EN} = 0$ ; $SEL_{0,1} = 0$ ; $T_j = 25\text{ °C}$ ; $V_{CC} = 13\text{ V}$			1	$\mu\text{A}$
		Off-state standby; $I_{N_A} = I_{N_B} = PWM = \text{Multisense\_EN} = 0$ ; $SEL_{0,1} = 0$ ; $V_{CC} = 13\text{ V}$ ; $T_j = 85\text{ °C}$			1	$\mu\text{A}$
		Off-state standby; $I_{N_A} = I_{N_B} = PWM = \text{Multisense\_EN} = 0$ ; $SEL_{0,1} = 0$ ; $V_{CC} = 13\text{ V}$ ; $T_j = 125\text{ °C}$			10	$\mu\text{A}$
		Off-state (no standby) $I_{N_A} = I_{N_B} = PWM = \text{Multisense\_EN} = 0$ ; $SEL_{0,1} = 5\text{ V}$	4	8	mA	
		On-state: $I_{N_A}$ or $I_{N_B} = 5\text{ V}$ ; $PWM = 0\text{ V}$ or $PWM = 5\text{ V}$ ; $SEL_0 = 0$ or $SEL_0 = 5\text{ V}$ ; $SEL_1 = 0$ or $SEL_1 = 5\text{ V}$	6	12	mA	
		On-state: $I_{N_A} = I_{N_B} = 5\text{ V}$ ; $PWM = 0\text{ V}$ or $PWM = 5\text{ V}$ ; $SEL_0 = 0$ or $SEL_0 = 5\text{ V}$ ; $SEL_1 = 0$ or $SEL_1 = 5\text{ V}$	9	18	mA	
$t_{D\_STBY}$	Standby mode blanking time	$V_{CC} = 13\text{ V}$ ; $I_{N_A} = I_{N_B} = SEL_1 = \text{MultiSense\_EN} = PWM = 0\text{ V}$ ; $V_{SEL0}$ from $5\text{ V}$ to $0\text{ V}$ .	60	300	550	$\mu\text{s}$
$R_{ONHS}$	Static high-side resistance	$I_{OUT} = 8\text{ A}$ ; $T_j = 25\text{ °C}$ , $V_{CC} = 13\text{ V}$		12		m $\Omega$
		$I_{OUT} = 8\text{ A}$ ; $T_j = -40\text{ °C}$ to $150\text{ °C}$			24	m $\Omega$
		$V_{CC} = 4\text{ V}$ , $I_{OUT} = 8\text{ A}$ , $T_j = 25\text{ °C}$		12		
$V_f$	High-side free-wheeling diode forward voltage	$I_{OUT} = -8\text{ A}$ ; $T_j = 150\text{ °C}$		0.6	0.7	V
$I_{L(off)}$	Off-State Output current of one output	$I_{N_A} = I_{N_B} = PWM = 0$ ; $V_{OUT} = 0\text{ V}$ ; $V_{CC} = 13\text{ V}$ ; $T_j = 25\text{ °C}$	0		0.5	$\mu\text{A}$
		$I_{N_A} = I_{N_B} = PWM = 0$ ; $V_{OUT} = 0\text{ V}$ ; $V_{CC} = 13\text{ V}$ ; $T_j = 125\text{ °C}$	0		5	$\mu\text{A}$
$I_{L(off\_h)}$	Off-state output current of one output with other HSD on	$I_{N_A} = PWM = 0$ ; $I_{N_B} = 5\text{ V}$ ; $V_{CC} = 13\text{ V}$	20		60	$\mu\text{A}$

Table 7. Logic inputs (IN<sub>A</sub>, IN<sub>B</sub>) (V<sub>CC</sub> = 7 V up to 28 V; -40 °C < T<sub>j</sub> < 150 °C)

Symbol	Parameter	Test conditions	Min.	Typ.	Max.	Unit
V <sub>IL</sub>	Input low level voltage				0.9	V
V <sub>IH</sub>	Input high level voltage		2.1			V
V <sub>IHYST</sub>	Input hysteresis voltage		0.2			V
V <sub>ICL</sub>	Input clamp voltage	I <sub>IN</sub> = 1 mA	5.3		7.2	V
		I <sub>IN</sub> = -1 mA		-0.7		V
I <sub>INL</sub>	Input current	V <sub>IN</sub> = 0.9 V	1			μA
I <sub>INH</sub>	Input current	V <sub>IN</sub> = 2.1 V			10	μA
<b>SEL<sub>0</sub>, SEL<sub>1</sub> (V<sub>CC</sub> = 7 V up to 18 V; -40 °C &lt; T<sub>j</sub> &lt; 150 °C)</b>						
V <sub>SELL</sub>	Input low level voltage				0.9	V
I <sub>SELL</sub>	Low level input current	V <sub>SEL</sub> = 0.9 V	1			μA
V <sub>SELH</sub>	Input high level voltage		2.1			V
I <sub>SELH</sub>	High level input current	V <sub>SEL</sub> = 2.1 V			10	μA
V <sub>SEL(hyst)</sub>	Input hysteresis voltage		0.2			V
V <sub>SELCL</sub>	Input clamp voltage	I <sub>SEL</sub> = 1 mA	5.3		7.2	V
		I <sub>SEL</sub> = -1 mA		-0.7		V
<b>PWM (V<sub>CC</sub> = 7 V up to 28 V; -40 °C &lt; T<sub>j</sub> &lt; 150 °C)</b>						
V <sub>PWM</sub>	Input low level voltage				0.9	V
I <sub>PWM</sub>	Low level input current	V <sub>PWM</sub> = 0.9 V	1			μA
V <sub>PWM</sub>	Input high level voltage		2.1			V
I <sub>PWMH</sub>	High level input current	V <sub>PWM</sub> = 2.1 V			10	μA
V <sub>PWM(hyst)</sub>	Input hysteresis voltage		0.2			V
V <sub>PMWCL</sub>	Input clamp voltage	I <sub>PWM</sub> = 1 mA	5.3		7.2	V
		I <sub>PWM</sub> = -1 mA		-0.7		V
<b>MultiSense_EN (V<sub>CC</sub> = 7 V up to 18 V; -40 °C &lt; T<sub>j</sub> &lt; 150 °C)</b>						
V <sub>SEnL</sub>	Input low level voltage				0.9	V
I <sub>SEnL</sub>	Low level input current	V <sub>SEn</sub> = 0.9 V	1			μA
V <sub>SEnH</sub>	Input high level voltage		2.1			V
I <sub>SEnH</sub>	High level input current	V <sub>SEn</sub> = 2.1 V			10	μA
V <sub>SEn(hyst)</sub>	Input hysteresis voltage		0.2			V
V <sub>SEnCL</sub>	Input clump voltage	I <sub>SEn</sub> = 1 mA	5.3		7.5	V
		I <sub>SEn</sub> = -1 mA		-0.7		V

Table 8. HSD switching ( $V_{CC} = 13\text{ V}$ ;  $R_{LOAD} = 1.6\ \Omega$ )

Symbol	Parameter	Test conditions	Min.	Typ.	Max.	Unit
$t_{d(on)}$	Turn-on delay time	Input rise time $< 1\ \mu\text{s}$ ; MultiSense_EN = 5 V (no standby); SEL <sub>0,1</sub> = 0; PWM = 0 (see Figure 6)		50		$\mu\text{s}$
$t_{d(off)}$	Turn-off delay time	Input rise time $< 1\ \mu\text{s}$ ; MultiSense_EN = 5 V (no standby); SEL <sub>0,1</sub> = 0; PWM = 0 (see Figure 6)		18		$\mu\text{s}$

Table 9. Gate driver for external MOS parameters ( $V_{CC} = 13\text{ V}$ )

Symbol	Parameter	Test conditions	Min.	Typ.	Max.	Unit
$f^{(1)}$	PWM frequency		0		20	kHz
$V_{gs\_lzd}$	Gate_LSD voltage	PWM = 5 V; IN <sub>x</sub> = 0 V			10	V
		$V_{CC} = 4\text{ V}$ , PWM = 5 V, IN <sub>x</sub> = 0 V, T <sub>j</sub> =25 °C		4		V
$t_{cross}$	Low-side turn-on delay time	Input rise time $< 1\ \mu\text{s}$ (see Figure 7)	40	160	300	$\mu\text{s}$
$t_{gr\_ls}$	Rise time	$V_{CC} = 13.5\text{ V}$ ; R <sub>g</sub> = 0 $\Omega$ ; C <sub>g</sub> = 4.7 nF (see Figure 5)		0.25	0.5	$\mu\text{s}$
$t_{gf\_ls}$	Fall time	$V_{CC} = 13.5\text{ V}$ ; R <sub>g</sub> = 0 $\Omega$ ; C <sub>g</sub> = 4.7 nF (see Figure 5)		0.35	0.5	$\mu\text{s}$

1. Parameter guaranteed by design.

Table 10. Protections and diagnostics ( $7\text{ V} < V_{CC} < 18\text{ V}$ ;  $-40\text{ }^\circ\text{C} < T_j < 150\text{ }^\circ\text{C}$ )

Symbol	Parameter	Test conditions	Min.	Typ.	Max.	Unit
$V_{USD}$	Undervoltage shutdown	$V_{CC}$ falling			4	V
$V_{USDreset}$	Undervoltage shutdown reset	$V_{CC}$ rising			5	V
$V_{USDhyst}$	Undervoltage shutdown hysteresis			0.3		V
$I_{LIM\_HSD}$	High-side current limitation		38	56	78	A
		$V_{CC} = 4\text{ V}$ , T <sub>j</sub> =25 °C <sup>(1)</sup>		50		A
$V_{CL\_HSD}$	High-side driver clamp voltage ( $V_{CC}$ to OUT <sub>A</sub> = 0 or OUT <sub>B</sub> = 0)	I <sub>OUT</sub> = 100 mA; t <sub>clamp</sub> = 1 ms; I <sub>clamp</sub> = 100 mA	38	46		V
$V_{CL\_LSD}^{(1)}$	Low-side clamp voltage (OUT <sub>A</sub> = $V_{CC}$ or OUT <sub>B</sub> = $V_{CC}$ to GND)	I <sub>OUT</sub> = 100 mA; t <sub>clamp</sub> = 1 ms; I <sub>clamp</sub> = 100 mA	38	46	52	V
$t_{DEL\_OVL\_LSD}$	Low-side drain-current overload blanking time		1		5	$\mu\text{s}$

Table 10. Protections and diagnostics (7 V < V<sub>CC</sub> < 18 V; -40 °C < T<sub>j</sub> < 150 °C) (continued)

Symbol	Parameter	Test conditions	Min.	Typ.	Max.	Unit
I <sub>REF_OVL_LSD</sub>	Low-side drain-current overload reference current		40	50	60	μA
V <sub>REF_OVL_LSD_MIN</sub>	Low-side drain-current overload threshold voltage minimum		0.32	0.4	0.48	V
V <sub>REF_OVL_LSD_MAX</sub>	Low-side drain-current overload threshold voltage maximum		1.6	2	2.4	V
T <sub>TSD_HSD</sub>	High-side thermal shutdown temperature	IN <sub>x</sub> = 2.1 V	150	175	200	°C
T <sub>TR_HSD</sub>	High-side thermal reset temperature		135			°C
T <sub>HYST_HSD</sub>	High-side thermal hysteresis (T <sub>SD_HSD</sub> - T <sub>R_HSD</sub> )			7		°C
ΔT <sub>j_SD</sub> <sup>(1)</sup>	Dynamic temperature			60		°C
I <sub>L(off3)</sub>	OFF-state output sink current with V <sub>OUT</sub> = V <sub>CC</sub>	IN <sub>A</sub> = IN <sub>B</sub> = 0; PWM = 0; V <sub>OUT</sub> = V <sub>CC</sub>	0	1.1	2.5	mA
V <sub>CL</sub>	Clamp signal (V <sub>CC</sub> to GND)	I <sub>OUT</sub> = 100 mA; t <sub>clamp</sub> = 1 ms; I <sub>clamp</sub> = 100 mA	38	46	52	V
V <sub>OL</sub>	OFF-state open-load voltage detection threshold	IN <sub>A</sub> = IN <sub>B</sub> = 0; PWM = 0; V <sub>SELO</sub> = 5 V for CHA; V <sub>SELO</sub> = 0 V and within t <sub>D_STBY</sub> for CHB	2	3	4	V
I <sub>L(off2)</sub>	OFF-state output sink current	IN <sub>A</sub> = IN <sub>B</sub> = 0; V <sub>OUT</sub> = 2 V; PWM = 0 V; V <sub>SELO</sub> = 5 V for CHA; V <sub>SELO</sub> = 0 V	-150		-5	μA
t <sub>DSTKON</sub>	OFF-state diagnostic delay time from falling edge of INPUT (see <a href="#">Figure 4</a> )	IN <sub>A</sub> = 5 V to 0 V; IN <sub>B</sub> = 0; PWM = 0; V <sub>SELO</sub> = 5 V; I <sub>OUT</sub> = 0 A; V <sub>OUTA</sub> = 4 V	40	160	300	μs
V <sub>GS_CP</sub>	CP output voltage	V <sub>CP</sub> - V <sub>BAT</sub> = V <sub>GS_CP</sub>	8	12	15	V
		V <sub>BAT</sub> = -16 V; V <sub>CP</sub> - V <sub>BAT</sub> = V <sub>GS_CP</sub>		0.6		V
t <sub>D_VOL</sub>	OFF-state diagnostic delay time from rising edge of V <sub>OUT</sub> (see <a href="#">Figure 10</a> )	IN <sub>A</sub> = IN <sub>B</sub> = 0 V; PWM = 0; V <sub>OUTx</sub> = 0 V to 4 V; V <sub>SELO</sub> = 5 V for CHA; V <sub>SELO</sub> = 0 V for CHB; V <sub>SELO,1</sub> = 0 V; SENSE_EN = 5 V		5	30	μs
t <sub>LATCH_RST_HS</sub>	Input reset time for high-side fault unlatch	V <sub>INx</sub> = 5 V to 0 V; HSDx faulting (see <a href="#">Figure 8</a> )	3	10	20	μs

Table 10. Protections and diagnostics (7 V < V<sub>CC</sub> < 18 V; -40 °C < T<sub>j</sub> < 150 °C) (continued)

Symbol	Parameter	Test conditions	Min.	Typ.	Max.	Unit
t <sub>LATCH_RST_LS</sub>	Input reset time for low-side fault unlatch	V <sub>INx</sub> = 0 V to 5 V; LSDx faulting (see <a href="#">Figure 9</a> )	3	10	20	μs
t <sub>stby_ovl_1sd</sub>	Low-side drain current overload delay time form stby exit	50% of V <sub>SENSEH</sub>		20		μs

1. Parameter guaranteed by design and characterization; not subject to production test.

Table 11. MultiSense (7 V < V<sub>CC</sub> < 18 V; -40 °C < T<sub>j</sub> < 150 °C)

Symbol	Parameter	Test conditions	Min.	Typ.	Max.	Unit
V <sub>SENSE_CL</sub>	MultiSense clamp voltage	V <sub>SEN</sub> = 0 V; I <sub>SENSE</sub> = -1 mA		7		V
		V <sub>SEN</sub> = 0 V; I <sub>SENSE</sub> = 1 mA	-17		-12	V
K <sub>OL</sub>	I <sub>OUT</sub> /I <sub>SENSE</sub>	I <sub>OUT</sub> = 0.3 A; V <sub>SENSE</sub> = 0.5 V; T <sub>j</sub> = -40 °C to 150 °C	6000	8000	10000	
K <sub>0</sub>	I <sub>OUT</sub> /I <sub>SENSE</sub>	I <sub>OUT</sub> = 4 A; V <sub>SENSE</sub> = 0.5 V; T <sub>j</sub> = -40 °C to 150 °C	6800	8000	9200	
K <sub>1</sub>	I <sub>OUT</sub> /I <sub>SENSE</sub>	I <sub>OUT</sub> = 8 A; V <sub>SENSE</sub> = 0.5 V; T <sub>j</sub> = -40 °C to 150 °C	7200	8000	8800	
K <sub>2</sub>	I <sub>OUT</sub> /I <sub>SENSE</sub>	I <sub>OUT</sub> = 16 A; V <sub>SENSE</sub> = 4 V; T <sub>j</sub> = -40 °C to 150 °C	7200	8000	8800	
dK <sub>OL</sub> /K <sub>OL</sub> <sup>(1)</sup>	Analog sense current drift	I <sub>OUT</sub> = 0.3 A; V <sub>SENSE</sub> = 0.5 V; T <sub>j</sub> = -40 °C to 150 °C	-12		12	%
dK <sub>0</sub> /K <sub>0</sub> <sup>(1)</sup>	Analog sense current drift	I <sub>OUT</sub> = 4 A; V <sub>SENSE</sub> = 0.5 V; V <sub>SENSE_EN</sub> = 0 V; T <sub>j</sub> = -40 °C to 150 °C	-5		5	%
dK <sub>1</sub> /K <sub>1</sub> <sup>(1)</sup>	Analog sense current drift	I <sub>OUT</sub> = 8 A; V <sub>SENSE</sub> = 0.5 V; V <sub>SENSE_EN</sub> = 0 V; T <sub>j</sub> = -40 °C to 150 °C	-5		5	%
dK <sub>2</sub> /K <sub>2</sub> <sup>(1)</sup>	Analog sense current drift	I <sub>OUT</sub> = 16 A; V <sub>SENSE</sub> = 4 V; T <sub>j</sub> = -40 °C to 150 °C	-5		5	%
V <sub>SENSE_SAT</sub>	Max analog sense output voltage	V <sub>CC</sub> = 7 V; R <sub>SENSE</sub> = 10 kΩ; I <sub>OUT</sub> = 16 A; V <sub>SEL0</sub> = 5 V; T <sub>j</sub> = 150 °C	5			V
I <sub>SENSE_SAT</sub> <sup>(2)</sup>	MultiSense saturation current	V <sub>CC</sub> = 7 V; V <sub>INA</sub> = 5 V; V <sub>INB</sub> = 0 V; V <sub>SEL0</sub> = 5 V; T <sub>j</sub> = 150 °C	3.8			mA
I <sub>OUT_SAT</sub> <sup>(2)</sup>	Output saturation current	V <sub>CC</sub> = 7 V; V <sub>SENSE</sub> = 4 V; V <sub>INA</sub> = 5 V; V <sub>INB</sub> = 0 V; V <sub>SEL0</sub> = 5 V; T <sub>j</sub> = 150 °C	33			A
V <sub>OUT_MSD</sub> <sup>(2)</sup>	Output Voltage for MultiSense shutdown	V <sub>INA</sub> = 5 V; V <sub>INB</sub> = 0 V; V <sub>SEL0</sub> = 5 V; V <sub>SEL1</sub> = 0 V; R <sub>SENSE</sub> = 2.7 kΩ; I <sub>OUT</sub> = 24 A		5		V

Table 11. MultiSense (7 V < V<sub>CC</sub> < 18 V; -40 °C < T<sub>j</sub> < 150 °C) (continued)

Symbol	Parameter	Test conditions	Min.	Typ.	Max.	Unit
I <sub>SENSE0</sub>	MultiSense leakage current	V <sub>MultiSense</sub> = V <sub>SENSE_EN</sub> = PWM = 0 V; I <sub>NA</sub> = I <sub>NB</sub> = 0 V; SEL <sub>0</sub> = SEL <sub>1</sub> = 0; T <sub>j</sub> = -40 °C to 150 °C (standby)	0		0.5	μA
		SEn = 5 V; I <sub>NA</sub> = I <sub>NB</sub> = 5 V; PWM = 0 V; SideX diagnostic selected; I <sub>OUTx</sub> = 0 A E.g. – SideA: SEL0 = 5 V; SEL1 = 0 V; I <sub>OUTA</sub> = 0 A; I <sub>OUTB</sub> = 12 A – SideB: SEL0 = 0 V; SEL1 = 0 V; I <sub>OUTA</sub> = 12 A; I <sub>OUTB</sub> = 0 V	0		14	μA
		SEn = 5 V; PWM = 0 V; SideX diagnostic selected; HSx OFF E.g. – SideA: SEL0 = 5 V; SEL1 = 0 V; I <sub>NA</sub> = 0 V; I <sub>NB</sub> = 5 V; I <sub>OUTB</sub> = 12 A – SideB: SEL0 = 0 V; SEL1 = 0 V; I <sub>NA</sub> = 5 V; I <sub>NB</sub> = 0 V; I <sub>OUTA</sub> = 12 A	0		10	μA
V <sub>SENSEH</sub>	MultiSense output voltage in fault condition	V <sub>CC</sub> = 13 V; R <sub>SENSE</sub> = 1 kΩ; – E.g: Ch <sub>0</sub> in open-load; V <sub>IN</sub> = 0 V; I <sub>OUT</sub> = 0 A; V <sub>OUT</sub> = 4 V	5		7	V
I <sub>SENSEH</sub>	MultiSense current in fault condition	9 V < V <sub>CC</sub> < 18 V; V <sub>SENSE</sub> = 5 V; MultiSense in fault condition	10	20	30	mA
<b>Chip temperature analog feedback</b>						
V <sub>SENSE_TC</sub>	MultiSense output voltage proportional to chip temperature	V <sub>SENSE_EN</sub> = 5 V; V <sub>SEL0</sub> = 0 V; V <sub>SEL1</sub> = 5 V; V <sub>IN</sub> = 0 V; R <sub>SENSE</sub> = 1 kΩ; T <sub>j</sub> = -40 °C	2.325	2.41	2.495	V
		V <sub>SENSE_EN</sub> = 5 V; V <sub>SEL0</sub> = 0 V; V <sub>SEL1</sub> = 5 V; V <sub>IN</sub> = 0 V; R <sub>SENSE</sub> = 1 kΩ; T <sub>j</sub> = 25 °C	1.985	2.07	2.155	V
		V <sub>SENSE_EN</sub> = 5 V; V <sub>SEL0</sub> = 0 V; V <sub>SEL1</sub> = 5 V; V <sub>IN</sub> = 5 V; R <sub>SENSE</sub> = 1 kΩ; T <sub>j</sub> = 125 °C	1.435	1.52	1.605	V
dV <sub>SENSE_TC</sub> /dT <sub>(2)</sub>	Temperature coefficient	T <sub>j</sub> = -40 °C to 150 °C		-5.5		mV/K
Transfer function		V <sub>SENSE_TC</sub> (T) = V <sub>SENSE_TC</sub> (T <sub>0</sub> ) + dV <sub>SENSE_TC</sub> /dT * (T - T <sub>0</sub> )				
<b>V<sub>CC</sub> supply voltage analog feedback</b>						
V <sub>SENSE_VCC</sub>	MultiSense output voltage proportional to V <sub>CC</sub> supply voltage	V <sub>CC</sub> = 13 V; V <sub>SENSE_EN</sub> = 5 V; V <sub>SEL0</sub> = V <sub>SEL1</sub> = 5 V; R <sub>SENSE</sub> = 1 kΩ	3.16	3.23	3.3	V
Transfer function		V <sub>SENSE_VCC</sub> = V <sub>CC</sub> /4				



Table 11. MultiSense (7 V < V<sub>CC</sub> < 18 V; -40 °C < T<sub>j</sub> < 150 °C) (continued)

Symbol	Parameter	Test conditions	Min.	Typ.	Max.	Unit
<b>MultiSense timings (Multiplexer transition times)<sup>(2)</sup></b>						
t <sub>D_CStoTC</sub>	MultiSense transition delay from current sense to T <sub>C</sub> sense	V <sub>INA</sub> = 5 V; V <sub>SENSE_EN</sub> = 5 V; V <sub>SEL0</sub> = 5 V to 0 V; V <sub>SEL1</sub> = 0 V to 5 V; I <sub>OUTA</sub> = 2.5 A; R <sub>SENSE</sub> = 1 kΩ; V <sub>SENSE_TC</sub> = 90% of V <sub>SENSE_TC_FINAL</sub>			60	μs
t <sub>D_TCtoCS</sub>	MultiSense transition delay from T <sub>C</sub> sense to current sense	V <sub>INA</sub> = 5 V; V <sub>SENSE_EN</sub> = 5 V; V <sub>SEL0</sub> = 0 V to 5 V; V <sub>SEL1</sub> = 5 V to 0 V; I <sub>OUTA</sub> = 2.5 A; R <sub>SENSE</sub> = 1 kΩ; I <sub>SENSE</sub> = 90% of I <sub>SENSE_MAX</sub>			20	μs
t <sub>D_CStoVCC</sub>	MultiSense transition delay from current sense to V <sub>CC</sub> sense	V <sub>INA</sub> = 5 V; V <sub>SENSE_EN</sub> = 5 V; V <sub>SEL0</sub> = 5 V; V <sub>SEL1</sub> = 0 V to 5 V; I <sub>OUTA</sub> = 2.5 A; R <sub>SENSE</sub> = 1 kΩ; V <sub>SENSE_VCC</sub> = 90% of V <sub>SENSE_VCC_FINAL</sub>			60	μs
t <sub>D_VCCtoCS</sub>	MultiSense transition delay from V <sub>CC</sub> sense to current sense	V <sub>INA</sub> = 5 V; V <sub>SENSE_EN</sub> = 5 V; V <sub>SEL0</sub> = 5 V; V <sub>SEL1</sub> = 5 V to 0 V; I <sub>OUTA</sub> = 2.5 A; R <sub>SENSE</sub> = 1 kΩ; I <sub>SENSE</sub> = 90% of I <sub>SENSE_MAX</sub>			20	μs
t <sub>D_TCtoVCC</sub>	MultiSense transition delay from T <sub>C</sub> sense to V <sub>CC</sub> sense	V <sub>CC</sub> = 13 V; T <sub>j</sub> = 125 °C; V <sub>SENSE_EN</sub> = 5 V; V <sub>SEL0</sub> = 0 V to 5 V; V <sub>SEL1</sub> = 5 V; R <sub>SENSE</sub> = 1 kΩ; V <sub>SENSE_VCC</sub> = 90% of V <sub>SENSE_VCC_FINAL</sub>			20	μs
t <sub>D_VCCtoTC</sub>	MultiSense transition delay from V <sub>CC</sub> sense to T <sub>C</sub> sense	V <sub>CC</sub> = 13 V; T <sub>j</sub> = 125 °C; V <sub>SENSE_EN</sub> = 5 V; V <sub>SEL0</sub> = 5 V to 0 V; V <sub>SEL1</sub> = 5 V; R <sub>SENSE</sub> = 1 kΩ; V <sub>SENSE_TC</sub> = 90% of V <sub>SENSE_TC_FINAL</sub>			20	μs
<b>MultiSense timings (CurrentSense mode)</b>						
t <sub>DSENSE1H</sub>	Current sense settling time from rising edge of V <sub>SENSE_EN</sub>	V <sub>INA</sub> = 5 V; V <sub>INB</sub> = 0 V; V <sub>SENSE_EN</sub> = 0 V to 5 V; R <sub>SENSE</sub> = 1 kΩ; R <sub>L</sub> = 2.6 Ω; V <sub>PWM</sub> = 5 V; V <sub>SEL0</sub> = 5 V; V <sub>SEL1</sub> = 0 V			60	μs
t <sub>DSENSE1L</sub>	Current sense disable delay time from falling edge of V <sub>SENSE_EN</sub>	V <sub>INA</sub> = 5 V; V <sub>INB</sub> = 0 V; V <sub>SENSE_EN</sub> = 5 V to 0 V; R <sub>SENSE</sub> = 1 kΩ; R <sub>L</sub> = 2.6 Ω; V <sub>PWM</sub> = 5 V; V <sub>SEL0</sub> = 5 V; V <sub>SEL1</sub> = 0 V			20	μs
t <sub>DSENSE2H</sub>	V <sub>SENSE_TC</sub> settling time from rising edge of V <sub>SENSE_EN</sub>	V <sub>SENSE_EN</sub> = 0 V to 5 V; V <sub>SEL0</sub> = 0 V; V <sub>SEL1</sub> = 5 V; R <sub>SENSE</sub> = 1 kΩ			60	μs

**Table 11. MultiSense (7 V < V<sub>CC</sub> < 18 V; -40 °C < T<sub>j</sub> < 150 °C) (continued)**

Symbol	Parameter	Test conditions	Min.	Typ.	Max.	Unit
t <sub>DSENSE2L</sub>	V <sub>SENSE_TC</sub> settling time from rising edge of V <sub>SENSE_EN</sub>	V <sub>SENSE_EN</sub> = 5 V to 0 V; V <sub>SELO</sub> = 0 V; V <sub>SEL1</sub> = 5 V; R <sub>SENSE</sub> = 1 kΩ			20	μs
<b>MultiSense timings (V<sub>CC</sub> voltage sensor mode)</b>						
t <sub>DSENSE3H</sub>	V <sub>SENSE_VCC</sub> settling time from rising edge of V <sub>SENSE_EN</sub>	V <sub>SENSE_EN</sub> = 0 V to 5 V; V <sub>SELO</sub> = 5 V; V <sub>SEL1</sub> = 5 V; R <sub>SENSE</sub> = 1 kΩ			60	μs
t <sub>DSENSE3L</sub>	V <sub>SENSE_VCC</sub> settling time from rising edge of V <sub>SENSE_EN</sub>	V <sub>SENSE_EN</sub> = 5 V to 0 V; V <sub>SELO</sub> = 5 V; V <sub>SEL1</sub> = 5 V; R <sub>SENSE</sub> = 1 kΩ			20	μs

1. Analog sense current drift is deviation of factor K for a given device over (-40°C to 150°C and 9 V < V<sub>CC</sub> < 18 V) with respect to its value measured at T<sub>j</sub> = 25 °C, V<sub>CC</sub> = 13 V.
2. Parameter guaranteed by design and characterization; not subject to production test.

**Figure 4. T<sub>DSTKON</sub>**

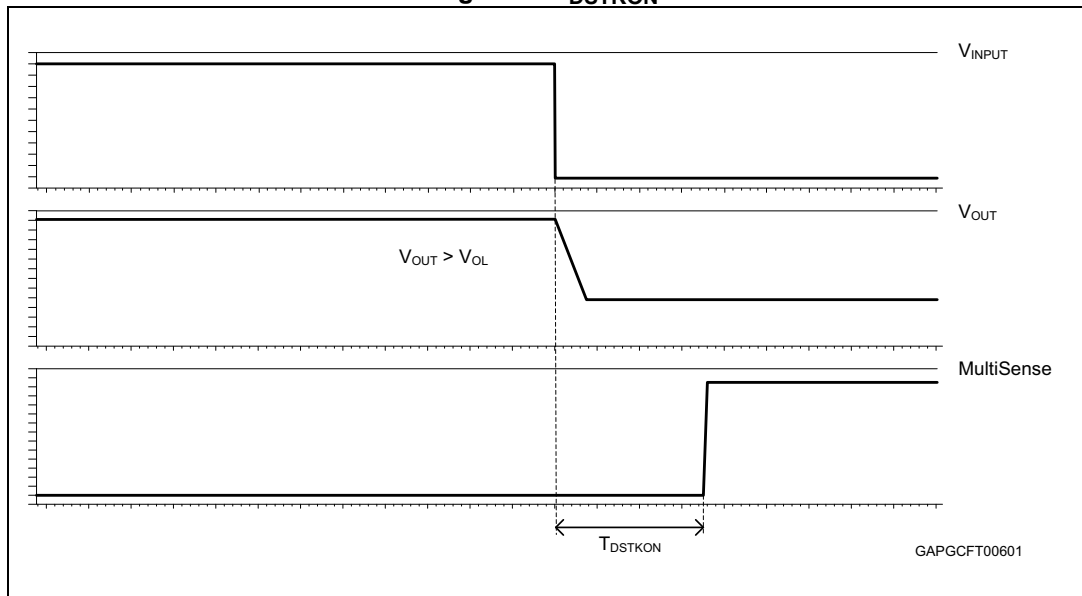


Figure 5. Definition of the low-side switching times

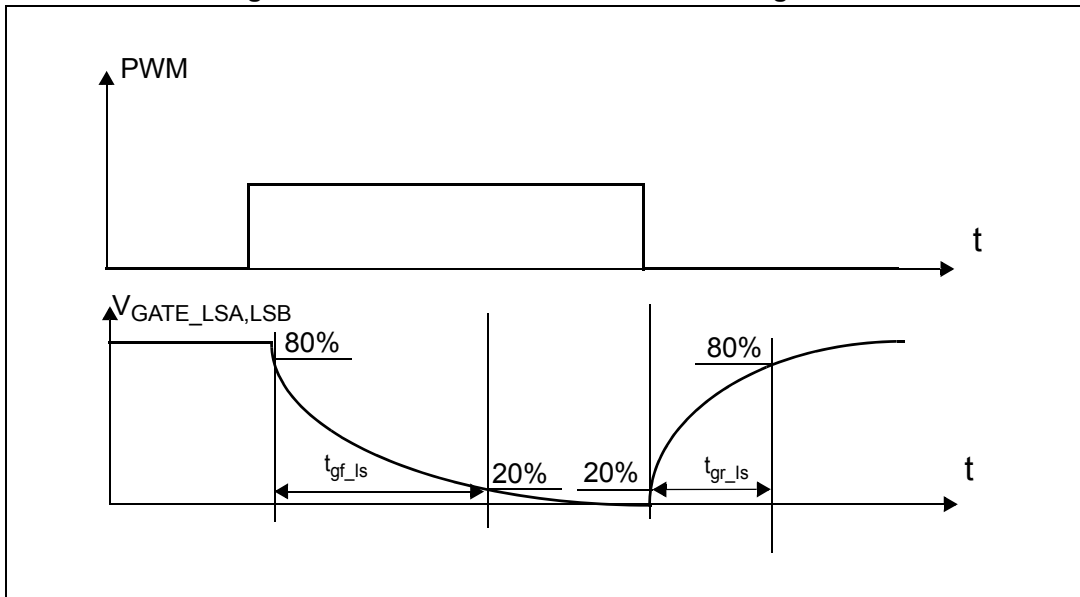


Figure 6. Definition of the high-side switching times

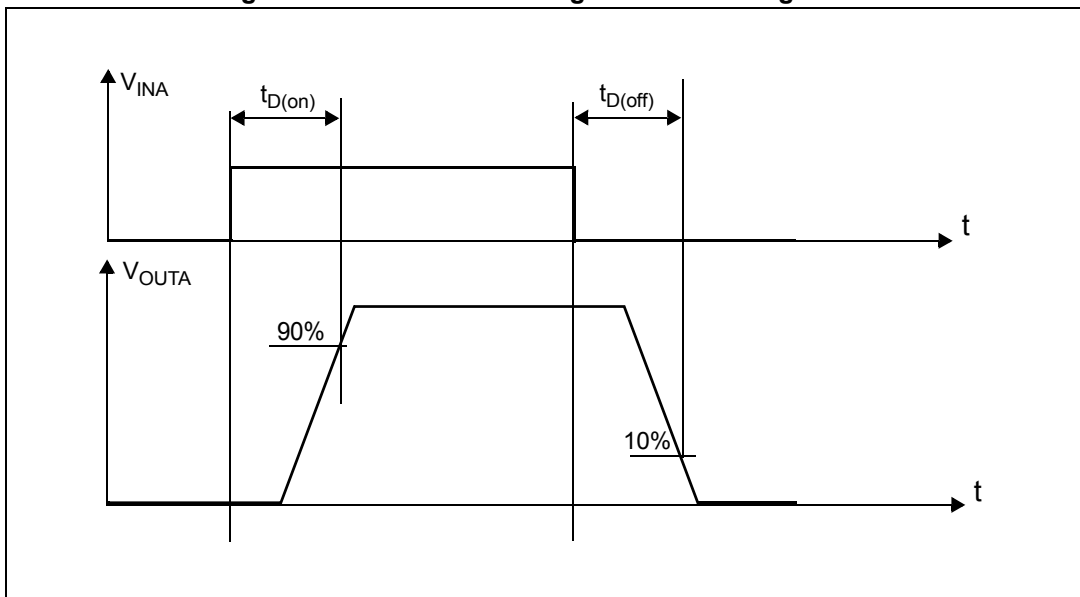


Figure 7. Low-side turn-on delay time

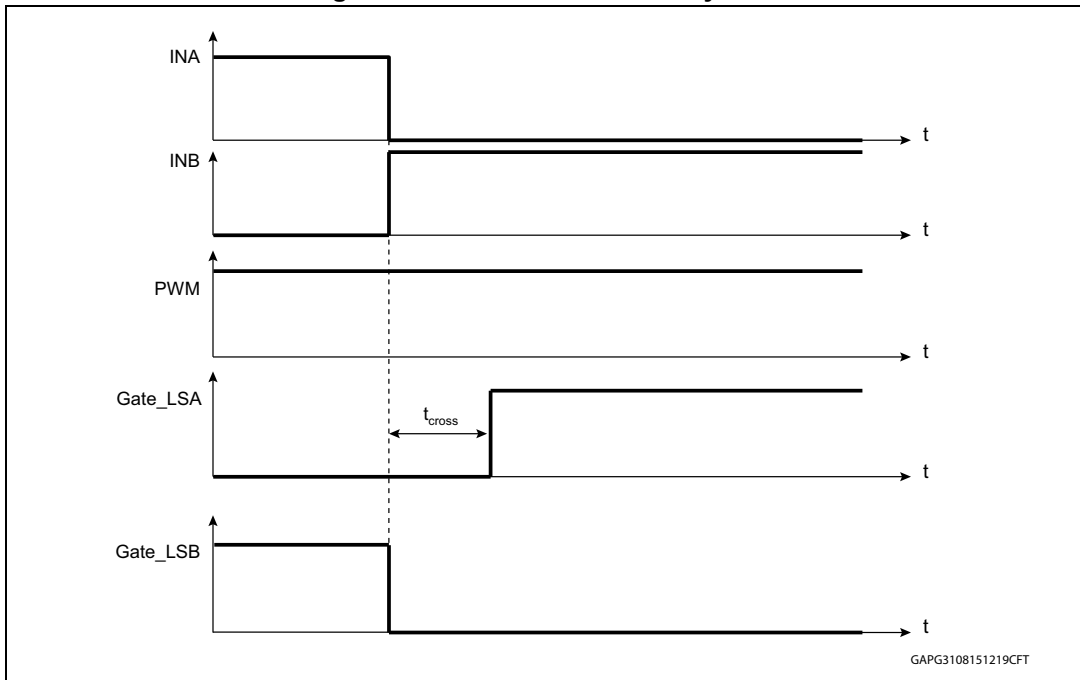
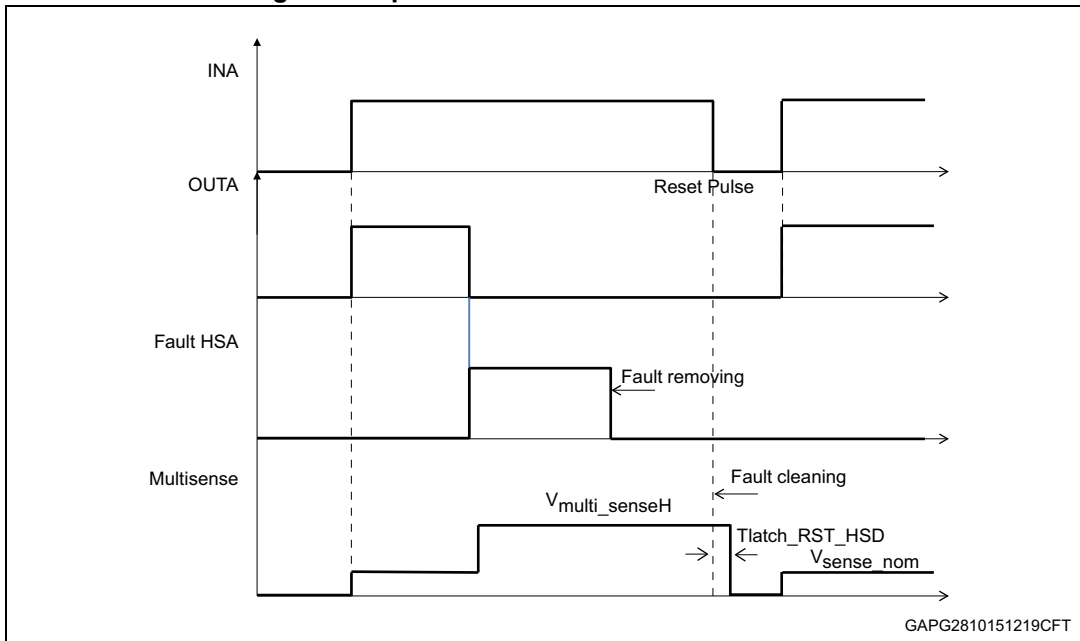
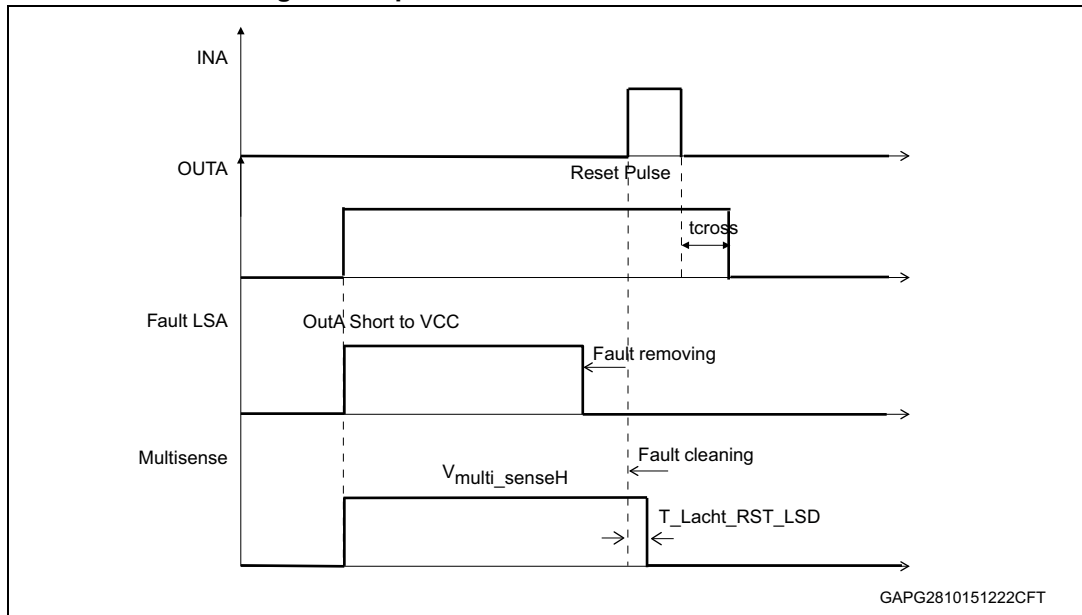


Figure 8. Input reset time for HSD-fault unlatch



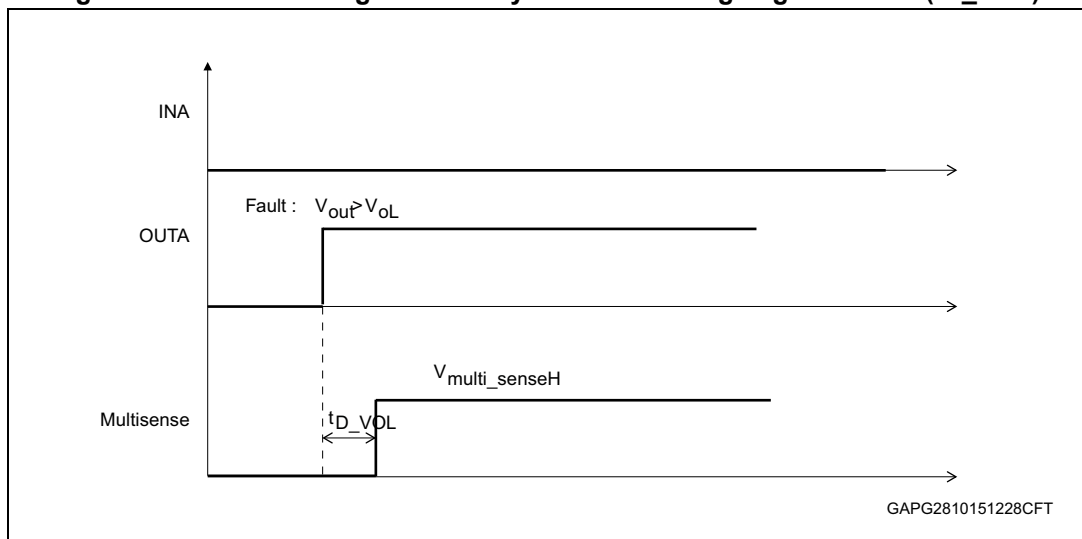
Note: *Multisense\_EN=1*

**Figure 9. Input reset time for LSD-fault unlatch**



Note: *Multisense\_EN=1*

**Figure 10. OFF-state diagnostic delay time from rising edge of VOUT ( $t_{D\_VOL}$ )**



Note: *Multisense\_EN=1.*

**Table 12. Operative condition - truth table**

INA	INB	PWM	SEL0	SEL1	MultiSense_EN	MultiSense	HSA	LSA	HSB	LSB
0	0	1	0	0	1	High-Z	OFF	ON	OFF	ON
		1	1	0	1	High-Z	OFF	ON	OFF	ON
0	1	0	0	0	1	Current Monitoring HSB	OFF	OFF	ON	OFF
		1	0	0	1	Current Monitoring HSB	OFF	ON	ON	OFF
0	1	0	1	0	1	High-Z	OFF	OFF	ON	OFF
		1	1	0	1	High-Z	OFF	ON	ON	OFF
1	0	0	0	0	1	High-Z	ON	OFF	OFF	OFF
		1	0	0	1	High-Z	ON	OFF	OFF	ON
1	0	0	1	0	1	Current Monitoring HSA	ON	OFF	OFF	OFF
		1	1	0	1	Current Monitoring HSA	ON	OFF	OFF	ON
1	1	X <sup>(1)</sup>	0	0	1	Current Monitoring HSB	ON	OFF	ON	OFF
			1	0	1	Current Monitoring HSA	ON	OFF	ON	OFF
0	0	0	1	0	1	Off-state diagnostic OUTA	OFF	OFF	OFF	OFF
0	0	0	0	0	1	Off-state diagnostic OUTB	OFF	OFF	OFF	OFF
X	X	X	0	1	1	T <sub>CHIP</sub> Monitoring	—	—	—	—
X	X	X	1	1	1	V <sub>CC</sub> Monitoring	—	—	—	—
X	X	X	X	X	0	High-Z <sup>(2)</sup>	—	—	—	—

1. X: the level of the pin can be 0 or 1.
2. When IN<sub>A</sub> = IN<sub>B</sub> = PWM = SEL0 = SEL1 = MultiSense\_EN = 0 device enters standby after T<sub>DSTBY</sub>.

**Table 13. On-state fault conditions- truth table**

Digital input pins <sup>(1)</sup>				MultiSense	Comment
INA	INB	PWM	SEL0		
0	0	1	0	V <sub>SENSE_H</sub>	VDS LSB protection triggered; LSB latched off
0	0	1	1	V <sub>SENSE_H</sub>	VDS LSA protection triggered; LSA latched off
0	1	X	0	V <sub>SENSE_H</sub>	HSB protection triggered; HSB latched off
0	1	1	1	V <sub>SENSE_H</sub>	VDS LSA protection triggered; LSA latched off
1	0	1	0	V <sub>SENSE_H</sub>	VDS LSB protection triggered; LSB latched off
1	0	X	1	V <sub>SENSE_H</sub>	HSA protection triggered; HSA latched off
1	1	X	0	V <sub>SENSE_H</sub>	HSB protection triggered; HSB latched off
1	1	X	1	V <sub>SENSE_H</sub>	HSA protection triggered; HSA latched off

1. MultiSense\_EN = 1 and SEL1 = 0 are mandatory for fault detection. Other logic combinations on digital input pins not reported on the above table do not allow to detect a latched-off channel.

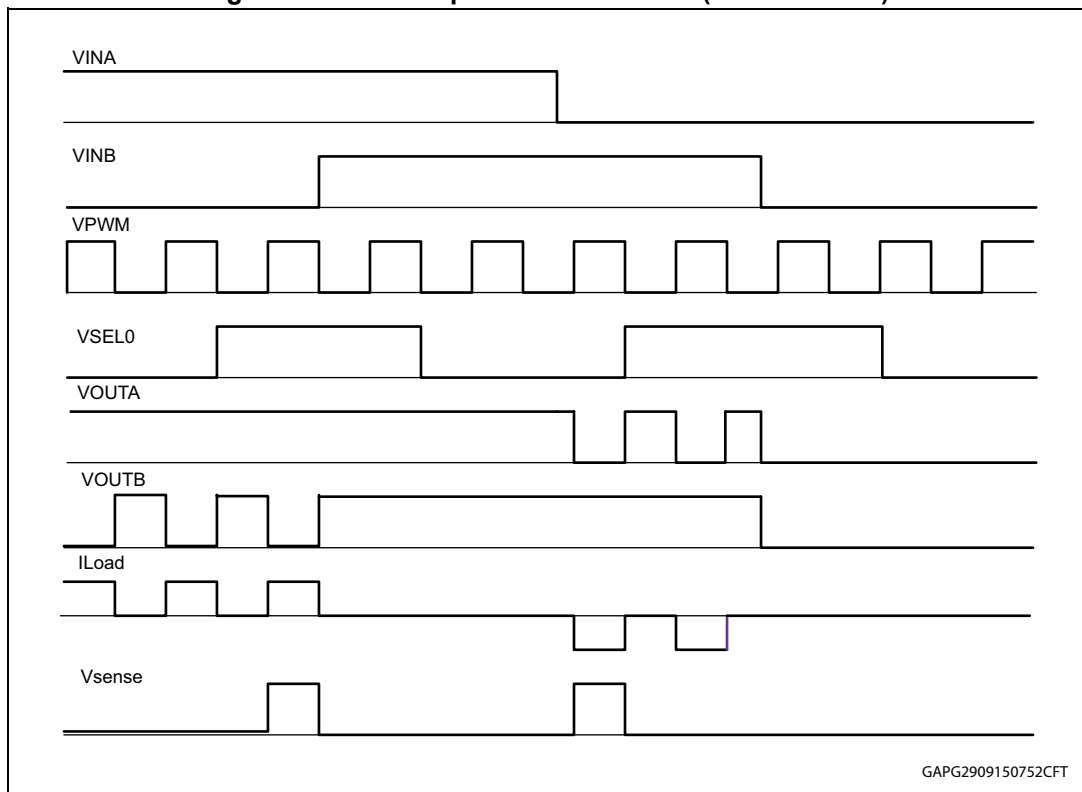
Table 14. Off-state — truth table

INA	INB	SEL0	SEL1	PWM	OUTA	OUTB	MultiSense_EN	MultiSense	Description
<b>Off-state diagnostic</b>									
0	0	1	0	0	$V_{OUTA} > V_{OL}$	X	1	$V_{SENSEH}$	<b>Case 1: <math>OUT_A</math> shorted to <math>V_{CC}</math></b> if no pull-up is applied. <b>Case 2: NO open-load</b> in full bridge configuration with an external pull-up on $OUT_B$ <b>Case 3: open-load</b> in half bridge configuration with an external pull-up on $OUT_A$ (motor connected between Out and Ground)
					$V_{OUTA} < V_{OL}$	X	1	Hi-Z	<b>Case 1: open-load</b> in full Bridge configuration with an external pull-up on $OUT_B$ <b>Case 2: NO open-load</b> in half Bridge configuration with external pull-up on $OUT_A$ (motor connected between Out and Ground)
		0	0		X	$V_{OUTB} > V_{OL}$	1	$V_{SENSEH}$	<b>Case 1: <math>OUT_B</math> shorted to <math>V_{CC}</math></b> if no pull-up is applied <b>Case 2: NO open-load</b> in full bridge configuration with external pull-up on $OUT_A$ <b>Case 3: open-load</b> in half bridge configuration with external pull-up on $OUT_B$ (motor connected between Out and Ground)
					X	$V_{OUTB} < V_{OL}$	1	Hi-Z	<b>Case1: open-load</b> in full Bridge configuration with an external pull-up on $OUT_A$ <b>Case 2. NO open-load</b> in half Bridge configuration with external pull-up on $OUT_B$ (motor connected between Out and Ground)

Note: To power on the device from standby, it is recommended to: toggle INA or INB or SEL0 or SEL1 from 0 to 1 first to come out from STBY mode; toggle PWM from 0 to 1 with a delay of 20 microsecond this avoids any overstress on the device in case of existing short-to-battery.

## 2.4 Waveforms

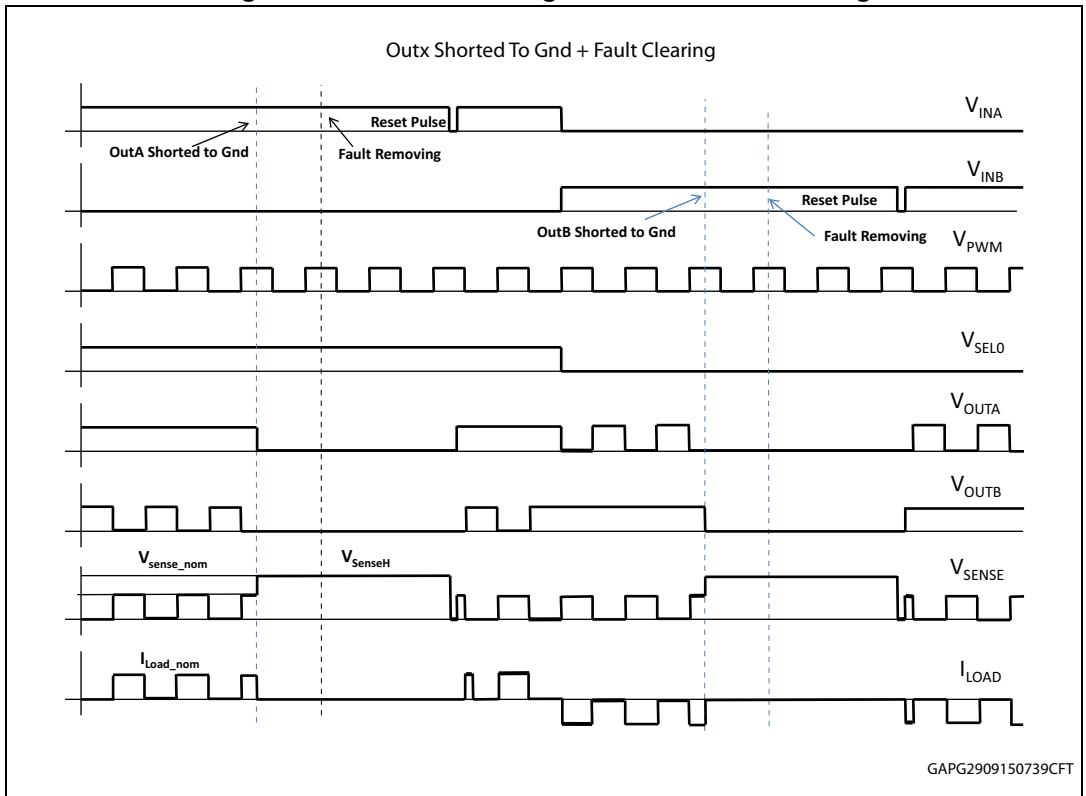
Figure 11. Normal operative conditions (resistive load)



Note: *MultiSense\_EN=1*

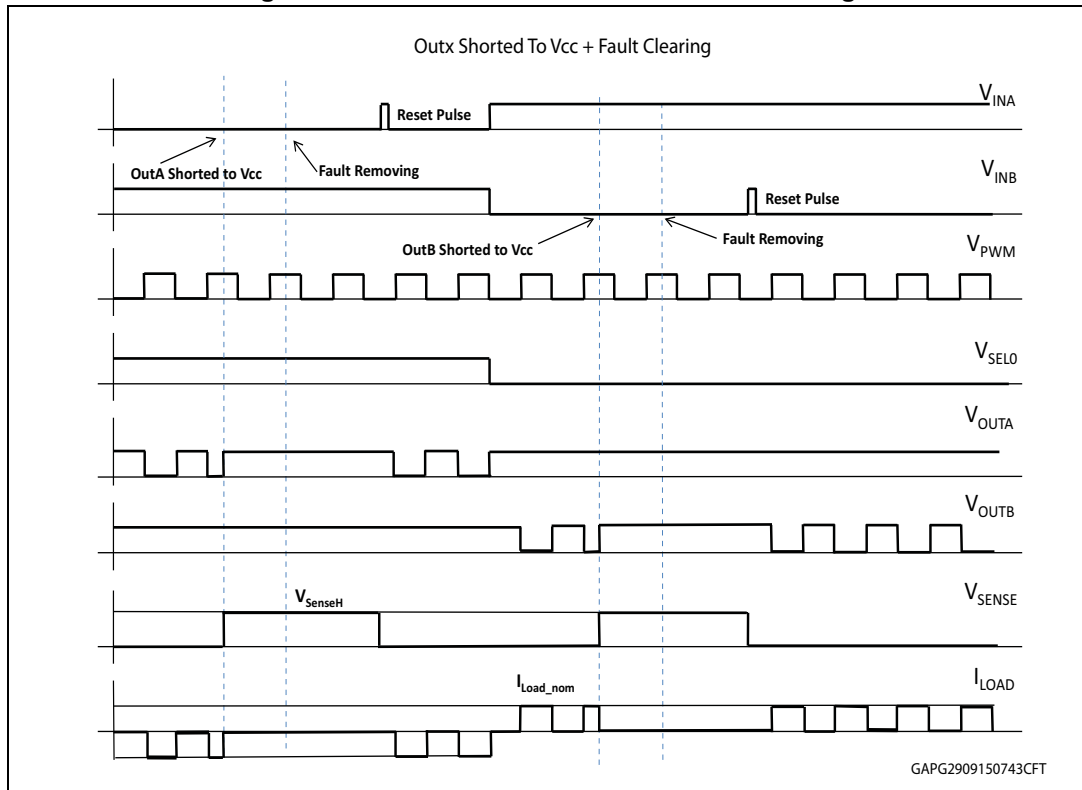


Figure 12. Out shorted to ground and short clearing



Note: *MultiSense\_EN=1*

Figure 13. OUT shorted to Vcc and short clearing



Note: MultiSense\_EN=1

Figure 14. Gate driver low side rise time normalized vs C<sub>g</sub> = 4.7nF

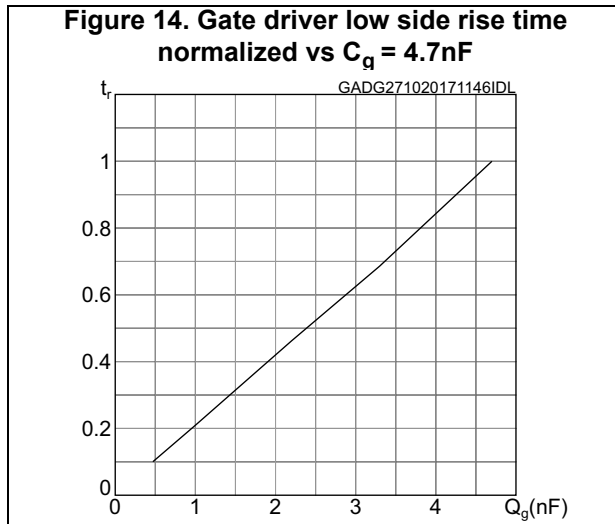
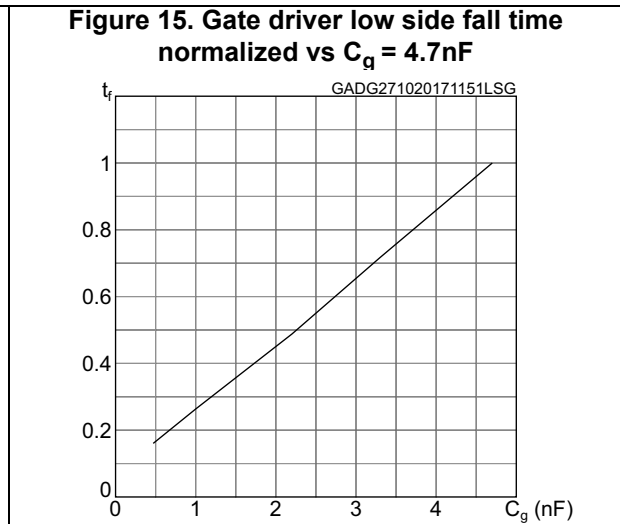


Figure 15. Gate driver low side fall time normalized vs C<sub>g</sub> = 4.7nF



## 3 Protections

### 3.1 Power limitation (high-side driver)

The basic working principle of this protection consists of an indirect measurement of the junction temperature swing  $\Delta T_j$  through the direct measurement of the spatial temperature gradient on the device surface in order to automatically shut off the output MOSFET as soon as  $\Delta T_j$  exceeds the safety level of  $\Delta T_{j\_SD}$ . The protection prevents fast thermal transient effects and, consequently, reduces thermo-mechanical fatigue. When Power Limitation is reached, The device enters in latch mode and generates the Fault Flag on Multisense = VsenseH when the faulty leg diagnostic is selected (please refer to [Table 13](#)).

### 3.2 Thermal shutdown

In case the junction temperature of the device exceeds the maximum allowed threshold (typically 175°C), the device enters in latch mode and generates the Fault Flag on Multisense = VsenseH (please refer to [Table 13](#)). The concerned high side can be switched ON again as soon as:  $T_j$  drops below TTR\_HSD, INX is set low for a duration > TLATCH\_RST\_HS and set high again.

### 3.3 High-side current limitation

The device is equipped with an output current limiter in order to protect the silicon as well as the other components of the system (e.g. bonding wires, wiring harness, connectors, loads, etc.) from excessive current flow. In case of short circuit, overload or during load power-up, the output current is clamped to a safety level, ILIMH, by operating the output power MOSFET in the active region

### 3.4 External PowerMOS low side VDS monitoring

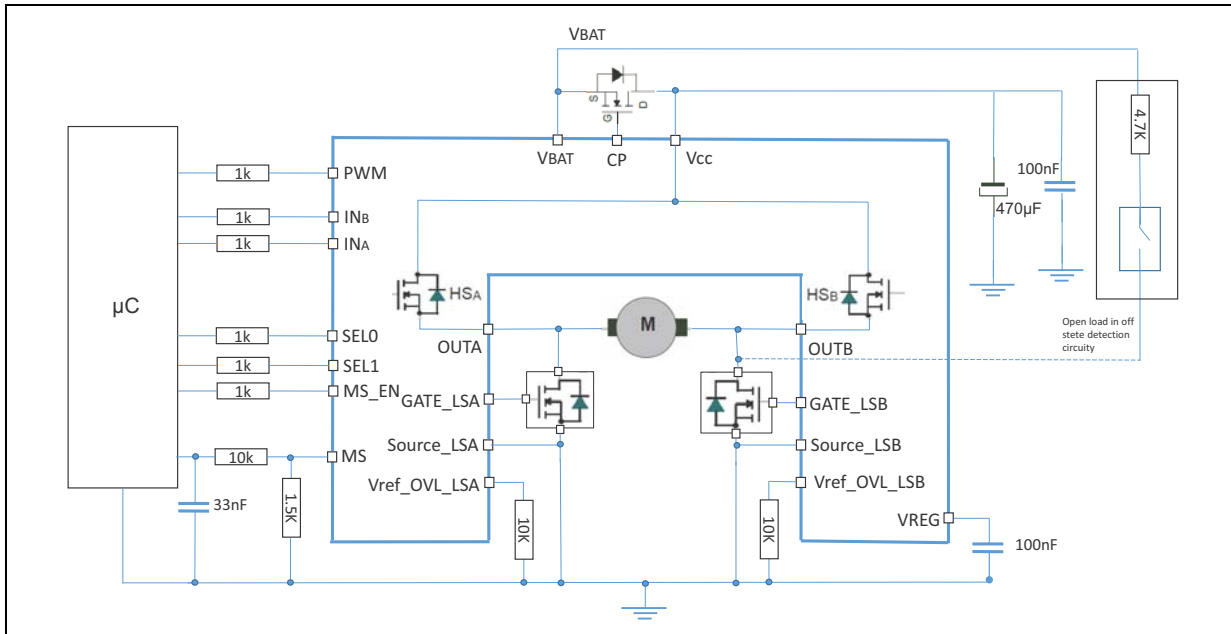
The VDS\_monitoring function has the ability to sense the OUTPUT Mosfet source voltage and compare it to a predetermined threshold. This threshold is programmable, using an internal reference current IREF\_OVL\_LSD = 50  $\mu$ A (typ.) and an external resistor connected at VREF\_OVL\_LS external pin.

This protection will be activated when the low side Power Mos is switched ON and its gate is fully charged: to guarantee this condition the function will detect a short to battery event only when PWM = H and after a blanking time tfil\_OVL\_LS= 2.2  $\mu$ s (typ.) starting from PWM rising edge. This feature is present for each LSD leg.

In case of fault conditions caused by Power Limitation or overtemperature or open load/short to VCC in OFF state, the fault is indicated by the MultiSense pin being internally switched to a "current limited" voltage source pulled to level V<sub>SENSEH</sub>.

# 4 Typical application schematic

Figure 16. Typical application schematic



Note: To protect the device against Battery disconnection with energized inductive load when the bridge driver goes into 3-state, suggested  $C(V_{CC})$  is:

$$C(V_{CC}) = \frac{E_{motor}}{0.5DV_{CC,max}^2}$$

where:

$E_{motor} = 33.5 \text{ mJ}$ ;

$DV_{CC,max} = V_{CC\_AMR} - V_{CC\_max}$ ;

$V_{CC\_AMR} = 38 \text{ V}$ ;

$V_{CC\_max} = 26 \text{ V}$  ( $V_{CC}$  at jump start);

$C(V_{CC}) = 470 \mu\text{F}$

## 5 MultiSense operation

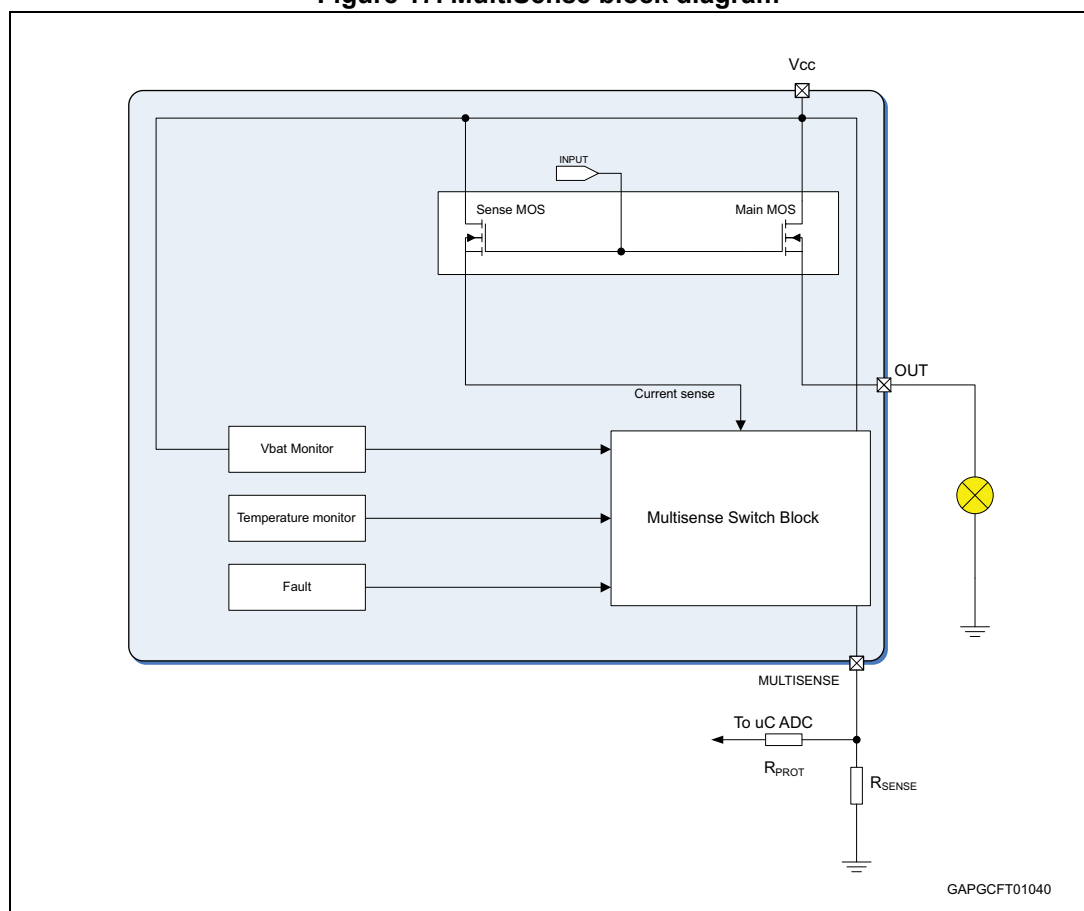
### 5.1 MultiSense analog monitoring

Diagnostic information on device and load status are provided by an analog output pin (MultiSense) delivering the following signals:

- Current monitor: current mirror of HSDx output current
- VCC monitor: voltage proportional to VCC
- TCASE: voltage proportional to chip temperature

Those signals are routed through an analog multiplexer which is configured and controlled by means of SELx and SEn pins, according to the address map in [Table 12](#).

**Figure 17. MultiSense block diagram**



### 5.2 Multisense diagnostics flag in fault conditions

Multisense pin delivers fixed voltage (VSENSEH) with a certain current capability in case of:

- fault condition on activated high-side triggered by Power Limitation
- fault condition on activated high-side triggered by overtemperature protection
- fault condition on VDS of Low side exceeded threshold

## 6 VREG and Driver\_LS Block

VREG pin is the output of an internal low drop voltage regulator. VREG block is designed to power the driver of external power Mosfet (Driver\_LS) and it allows a proper MOS transition.

- VREG out voltage will be VREG=10V if Vbattery > 10V, while VREG = Vbattery if Vbattery < 10V.

An external capacitor C<sub>REG</sub> = 100 nF connected to the pin VREG is needed to proper polarize the circuit (see [Figure 16](#)).

## 7 Reverse battery protection

CP pin provides the necessary gate drive for an external n-channel PowerMOS used for reverse polarity protection. The external N-channel Power MOSFET used for the reverse battery protection should have the following characteristics:

- BVdss > 20 V (for a reverse battery of -16 V);
- RDS(on) < 1/3 of H-bridge total RDS(on)
- Standard Logic Gate Driving

## 8 Open-load detection in off-state

The Open Load (OL) detection in off-state operates when output is deactivated (means INA = INB = PWM=0, or INB together with PWM=0). Open load detection is performed by reading the MultiSense output. External (switched) pull-up resistor has to be used and dimensioned to pull output voltage above the maximum open load detection voltage (VOL MAX) when load is not connected and as well stays below the minimum level (VOL MIN) when load is connected.

When the open load is detected, VsenseH is indicated on Multisense pin, possible conditions are specified in [Table 14](#).

If pull up resistor is applied over switched circuitry, it allows to detect short to VCC from open-load (see [Figure 16](#)).

The RPU value has to be:

$$R_{\text{pull\_up}} < \frac{V_{\text{BATTmin}} - V_{\text{OLmax}}}{2 \times I_{\text{L(off2)min}} [\text{@VOLmax}]}$$

## 9 Immunity against transient electrical disturbances

The immunity of the device against transient electrical emissions, conducted along the supply lines and injected into the VCC pin, is tested in accordance with ISO7637-2:2011 (E) and ISO 16750-2:2010.

The related function performance status classification is shown in [Table 15](#).

Test pulses are applied directly to DUT (Device Under Test) both in ON and OFF-state and in accordance to ISO 7637-2:2011(E), chapter 4. The DUT is intended as the present device only, without components and accessed through VCC and GND terminals.

Status II is defined in ISO 7637-1 Function Performance Status Classification (FPSC) as follows: "The function does not perform as designed during the test but returns automatically to normal operation after the test".

**Table 15. IISO 7637-2 - electrical transient conduction along supply line**

Test pulse 2011(E)	Test pulse severity level with status II functional performance status		Minimum number of pulses or test time	Burst cycle/pulse repetition time		Pulse duration and pulse generator internal impedance
	Level	$U_S^{(1)}$		min.	max.	
1	III	-112 V	500 pulses	0.5 s		2 ms, 10 $\Omega$
2a	III	+55	500 pulses	0.2 s	5 s	50 $\mu$ s, 2 $\Omega$
3a	IV	-220 V	1h	90 ms	100 ms	0.1 $\mu$ s, 50 $\Omega$
3b	IV	+150 V	1h	90 ms	100 ms	0.1 $\mu$ s, 50 $\Omega$
4 <sup>(2)</sup>	IV	-7 V	1 pulse			100 ms, 0.01 $\Omega$
<b>Load dump according to ISO 16750-2:2010</b>						
Test B <sup>(3)</sup>		40 V	5 pulse	1 min		400 ms, 2 $\Omega$

1.  $U_S$  is the peak amplitude as defined for each test pulse in ISO 7637-2:2011(E)
2. Test pulse from ISO 7637-2:2004(E)
3. With 40 V external suppressor referred to ground ( $-40\text{ }^\circ\text{C} < T_J < 150\text{ }^\circ\text{C}$ )

# 10 Package and PCB thermal data

## 10.1 PowerSSO-36 thermal data

Figure 18. PowerSSO-36 PCB board

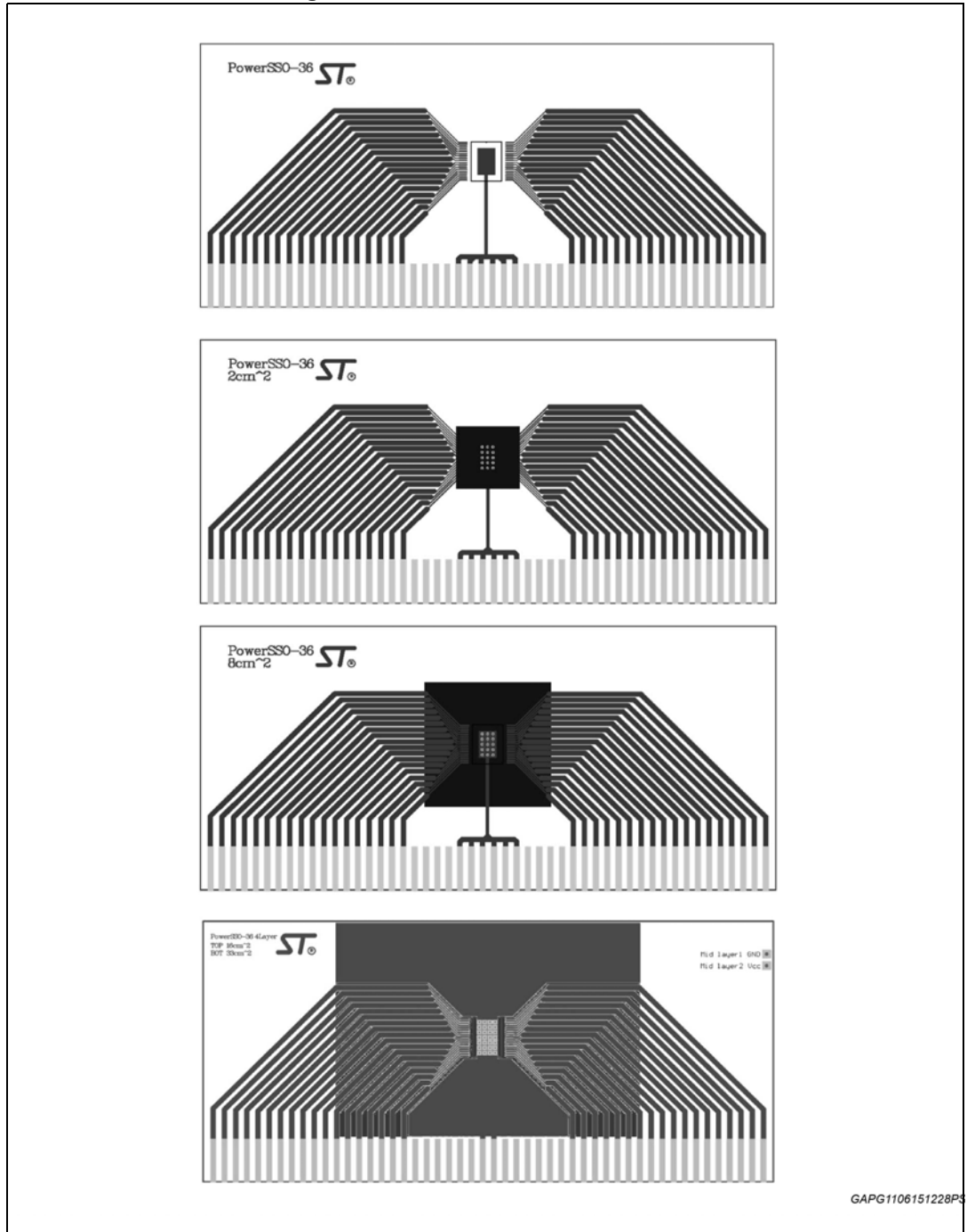
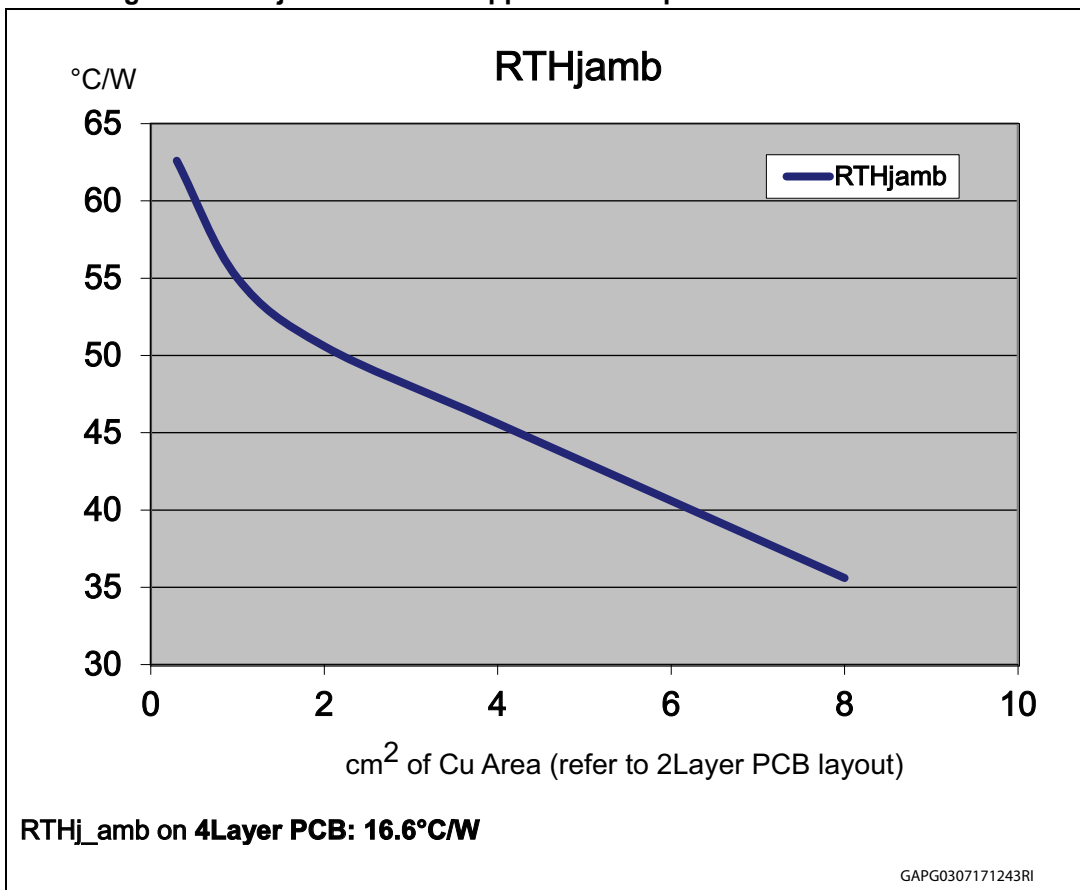




Table 16. PCB properties

Dimension	Value
Board finish thickness	1.6 mm +/- 10%
Board dimension	129 mm x 60 mm
Board material	FR4
Cu thickness (outer layers)	0.070 mm
Cu thickness (inner layers)	0.035 mm
Thermal via separation	1.2 mm
Thermal via diameter	0.3 mm +/- 0.08 mm
Cu thickness on vias	0.025 mm
Footprint dimension	4.1 mm x 6.5 mm

Figure 19. Rthj-amb vs PCB copper area in open box free air condition

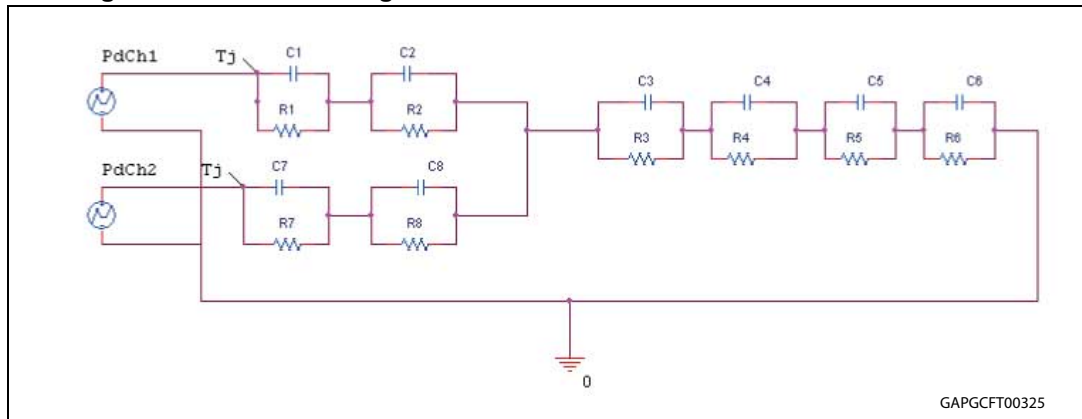


Equation 1: pulse calculation formula

$$ZTH\delta = RTH \cdot \delta + ZTHtp (1 - \delta)$$

where  $\delta = tP/T$

Figure 20. Thermal fitting model of a double-channel HSD in PowerSSO-36



Note: The fitting model is a simplified thermal tool and is valid for transient evolutions where the embedded protections (power limitation or thermal cycling during thermal shutdown) are not triggered.

Figure 21. Thermal impedance junction ambient single pulse

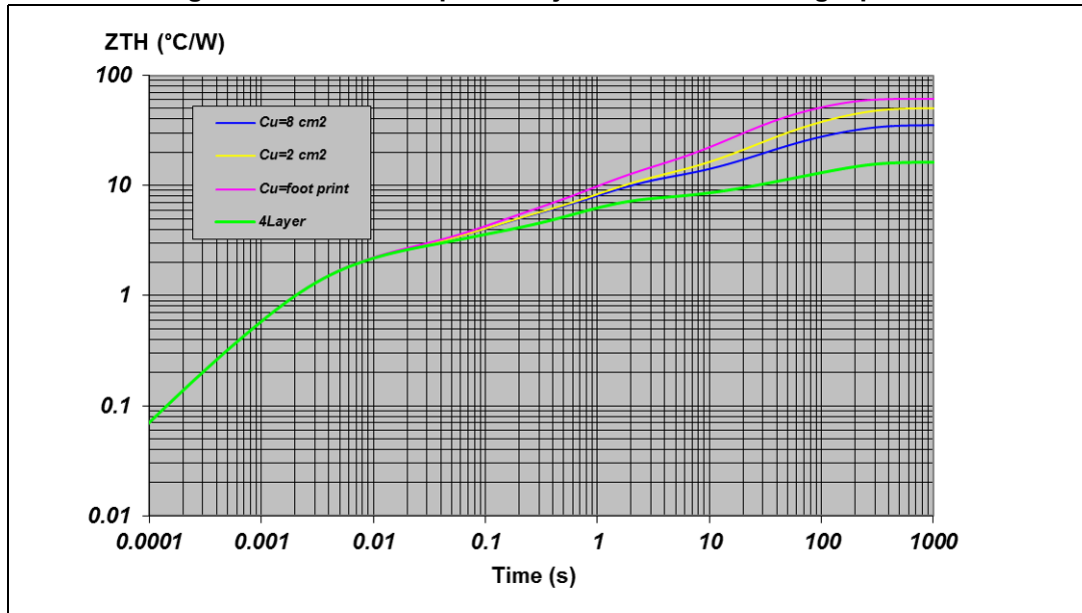


Table 17. Thermal parameters

Area / island	FP	2	8	4L
R1 (°C/W)	0.95			
R2 (°C/W)	1.3			
R3 (°C/W)	2	2	2	1
R4 (°C/W)	7	6	6	4
R5 (°C/W)	20	14	10	2
R6 (°C/W)	30	26	15	7

Table 17. Thermal parameters (continued)

Area / island	FP	2	8	4L
R7 (°C/W)	0.95			
R8 (°C/W)	1.3			
C1 (W•s/°C)	0.002			
C2 (W•s/°C)	0.005			
C3 (W•s/°C)	0.05	0.05	0.05	0.05
C4 (W•s/°C)	0.15	0.2	0.2	0.2
C5 (W•s/°C)	1	2	3	10
C6 (W•s/°C)	3	5	9	18
C7 (W•s/°C)	0.002			
C8 (W•s/°C)	0.005			

# 11 Package and packing information

In order to meet environmental requirements, ST offers these devices in different grades of ECOPACK® packages, depending on their level of environmental compliance. ECOPACK® specifications, grade definitions and product status are available at: [www.st.com](http://www.st.com).  
 ECOPACK® is an ST trademark.

## 11.1 PowerSSO-36 package information

Figure 22. PowerSSO-36 package dimensions

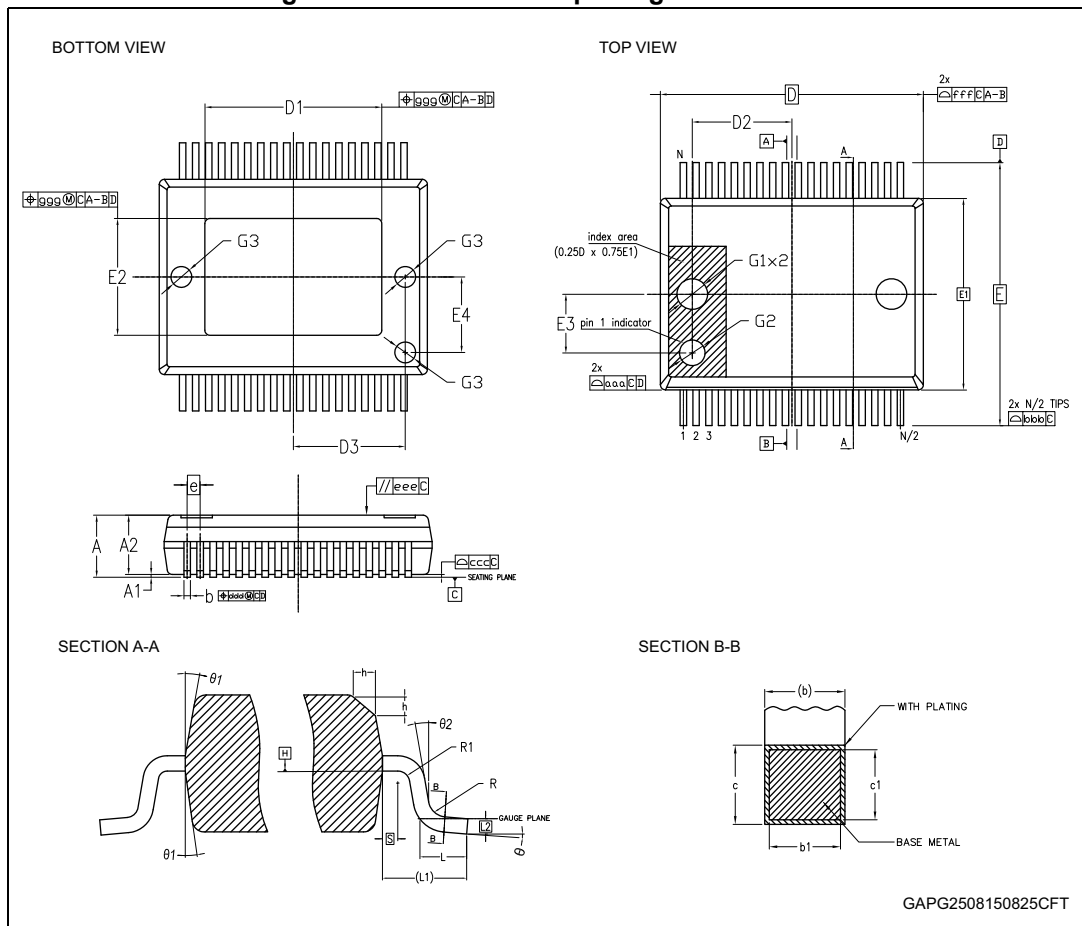


Table 18. PowerSSO-36 (exposed pad) package mechanical data

Ref	Millimeters		
	Min.	Typ.	Max.
Θ	0°	-	8°
Θ1	5°	-	10°
Θ2	0°	-	-

Table 18. PowerSSO-36 (exposed pad) package mechanical data (continued)

Ref	Millimeters		
	Min.	Typ.	Max.
A	2.15	-	2.45
A1	0.0	-	0.1
A2	2.15	-	2.35
b	0.18	-	0.32
b1	0.13	0.25	0.3
c	0.23	-	0.32
c1	0.2	0.2	0.3
D <sup>(1)</sup>	10.30 BSC		
D1	6.9	-	7.5
D2	-	3.65	-
D3	-	4.3	-
e	0.50 BSC		
E	10.30 BSC		
E1 <sup>(1)</sup>	7.50 BSC		
E2	4.3	-	5.2
E3	-	2.3	-
E4	-	2.9	-
G1	-	1.2	-
G2	-	1	-
G3	-	0.8	-
h	0.3	-	0.4
L	0.55	0.7	0.85
L1	1.40 REF		
L2	0.25 BSC		
N	36		
R	0.3	-	-
R1	0.2	-	-
S	0.25	-	-
<b>Tolerance of form and position</b>			
aaa	0.2		
bbb	0.2		
ccc	0.1		
ddd	0.2		

**Table 18. PowerSSO-36 (exposed pad) package mechanical data (continued)**

Ref	Millimeters		
	Min.	Typ.	Max.
eee	0.1		
fff	0.2		
ggg	0.15		

1. Dimensions D and E1 do not include mold flash or protrusions. Allowable mold flash or protrusions is '0.25 mm' per side D and '0.15 mm' per side E1. D and E1 are Maximum plastic body size dimensions including mold mismatch.

## 11.2 PowerSSO-36 packing information

**Figure 23. PowerSSO-36 tube shipment (no suffix)**

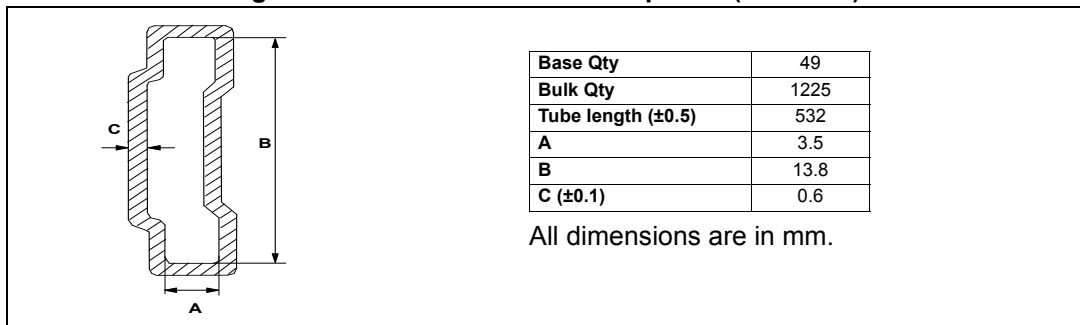
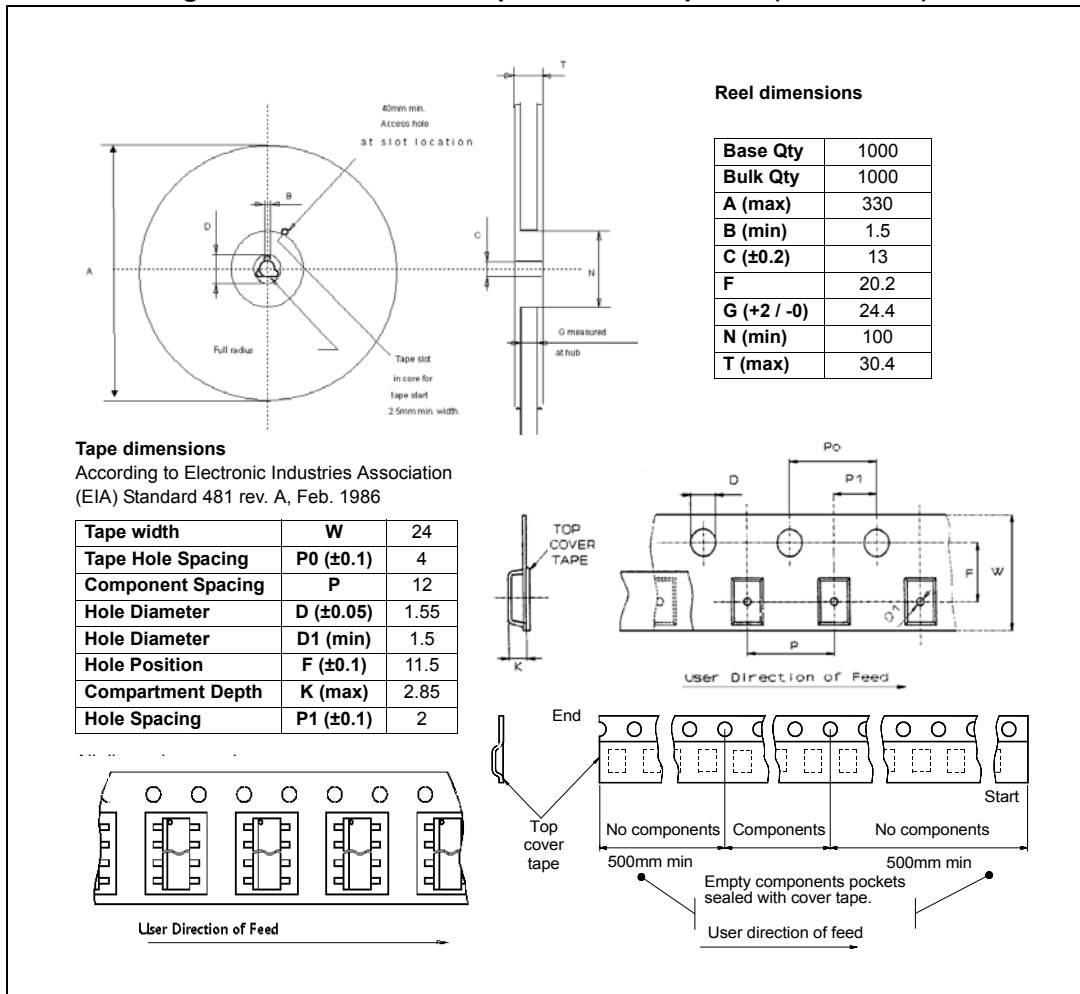
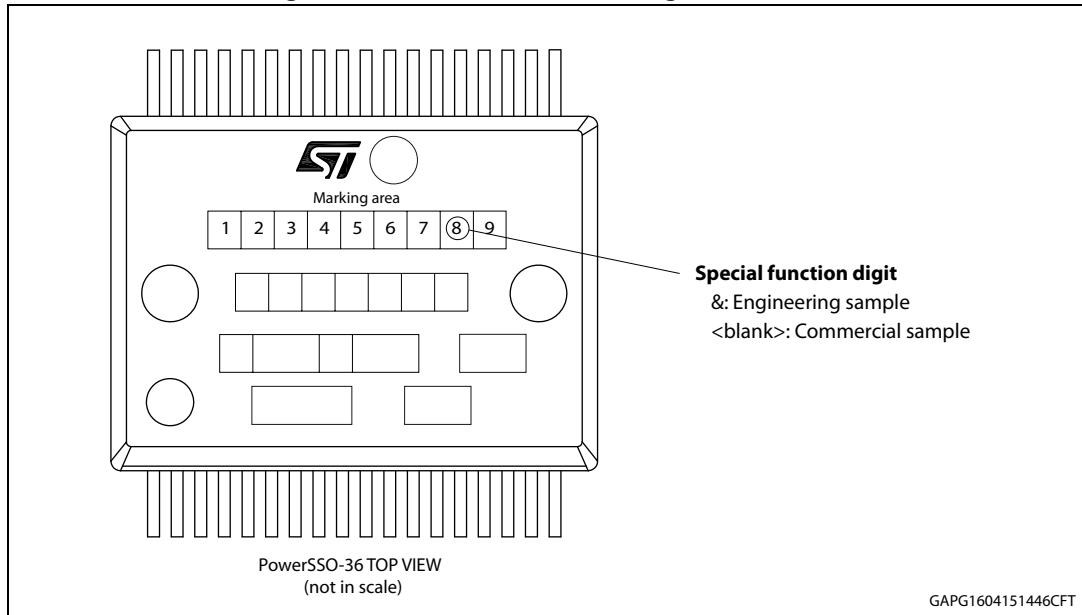


Figure 24. PowerSSO-36 tape and reel shipment (suffix "TR")



### 11.3 PowerSSO-36 marking information

Figure 25. PowerSSO-36 marking information



*Note: Engineering Samples: these samples can be clearly identified by a dedicated special symbol in the marking of each unit. These samples are intended to be used for electrical compatibility evaluation only; usage for any other purpose may be agreed only upon written authorization by ST. ST is not liable for any customer usage in production and/or in reliability qualification trials.*

*Note: Commercial Samples: fully qualified parts from ST standard production with no usage restrictions.*



## 12 Order codes

Table 19. Device summary

Package	Order codes	
	Tube	Tape and reel
PowerSSO-36	VNHD7012AY	VNHD7012AYTR

## 13 Revision history

**Table 20. Document revision history**

Date	Revision	Description of changes
14-Nov-2017	1	Initial release.
11-Apr-2018	2	<p>In Cover page:</p> <ul style="list-style-type: none"> <li>– updated value of “<math>I_{out}</math>” from 40 A to 38 A</li> <li>– updated feature “Output current = 40 A” with “Output current = 38 A”</li> <li>– removed “MO” from sentence “ The device is designed using STMicroelectronics...”</li> </ul> <p>In <a href="#">Table 10: Protections and diagnostics (7 V &lt; VCC &lt; 18 V; -40 °C &lt; Tj &lt; 150 °C)</a>:</p> <ul style="list-style-type: none"> <li>– Updated min value of “<math>I_{LIM\_HSD}</math>” parameter from 40 A to 38 A</li> <li>– Fixed typ. value “<math>I_{LIM\_HSD}</math>” parameter to 50 A</li> <li>– Updated max value of “<math>I_{LIM\_HSD}</math>” parameter from 80 A to 78 A</li> <li>– Updated min value of “<math>t_{DEL\_OVL\_LSD}</math>” parameter from 0.05 <math>\mu</math>s to 1 <math>\mu</math>s</li> <li>– Updated test condition of “<math>I_{L(off2)}</math>” parameter from “PWM = 2 V” to “PWM = 0 V”</li> <li>– Removed “and within <math>t_{D\_STBY}</math> for CHB” from test condition of “<math>I_{L(off2)}</math>” parameter</li> <li>– Updated test condition of “<math>t_{D\_VOL}</math>” parameter from “<math>V_{SEL1} = 0</math> V for CHA;” to “<math>V_{SEL0} = 5</math> V for CHA; <math>V_{SEL0} = 0</math> V for CHB;” and removed “for CHB”</li> </ul> <p>In <a href="#">Table 11: MultiSense (7 V &lt; VCC &lt; 18 V; -40 °C &lt; Tj &lt; 150 °C)</a>:</p> <ul style="list-style-type: none"> <li>– Updated min value of “<math>I_{SENSE\_SAT}</math>” parameter from 4 mA to 3.8 mA</li> <li>– Updated min value of “<math>I_{OUT\_SAT}</math>” parameter from 48 A to 33 A</li> <li>– Updated max value of “<math>I_{SENSE0}</math>” parameter from 10 <math>\mu</math>A to 14 <math>\mu</math>A</li> </ul> <p>In <a href="#">Table 16: PCB properties</a> updated value of “Board dimension” from “129 mm x 86 mm” to “129 mm x 60 mm”</p> <p>Updated <a href="#">Figure 21: Thermal impedance junction ambient single pulse</a></p> <p>Updated <a href="#">Table 17: Thermal parameters</a></p>
12-Jul-2018	3	<p>Updated from target spec to production data.</p> <p>Updated <a href="#">Table 4: Absolute maximum ratings</a> (add <math>V_{BAT}</math> value).</p> <p>Updated <a href="#">Table 10: Protections and diagnostics (7 V &lt; VCC &lt; 18 V; -40 °C &lt; Tj &lt; 150 °C)</a> (add Min. and Max. values in <math>V_{GS\_CP}</math>).</p>

**IMPORTANT NOTICE – PLEASE READ CAREFULLY**

STMicroelectronics NV and its subsidiaries ("ST") reserve the right to make changes, corrections, enhancements, modifications, and improvements to ST products and/or to this document at any time without notice. Purchasers should obtain the latest relevant information on ST products before placing orders. ST products are sold pursuant to ST's terms and conditions of sale in place at the time of order acknowledgement.

Purchasers are solely responsible for the choice, selection, and use of ST products and ST assumes no liability for application assistance or the design of Purchasers' products.

No license, express or implied, to any intellectual property right is granted by ST herein.

Resale of ST products with provisions different from the information set forth herein shall void any warranty granted by ST for such product.

ST and the ST logo are trademarks of ST. All other product or service names are the property of their respective owners.

Information in this document supersedes and replaces information previously supplied in any prior versions of this document.

© 2018 STMicroelectronics – All rights reserved

# Mouser Electronics

Authorized Distributor

Click to View Pricing, Inventory, Delivery & Lifecycle Information:

[STMicroelectronics:](#)

[VNHD7012AYTR](#)