



LM2954

LINEAR INTEGRATED CIRCUIT

300mA LOW-DROPOUT VOLTAGE REGULATOR

DESCRIPTION

The UTC **LM2954** is a monolithic integrated voltage regulator with low dropout voltage, and low quiescent current. It includes many features that suitable for different applications with TO-92, DIP-8, SOP-8 and SOT-223 packages.

FEATURES

- *High Accuracy Fixed Output.
- *Output Voltage Programmable and Logic Controlled Shutdown And Error Flag Available for DIP and SOP Package.
- *Extremely Low Quiescent Current And Dropout Voltage.
- *Extremely Tight Load And Line Regulation.
- *Current and Thermal Limiting.
- *Very low Temperature Coefficient.

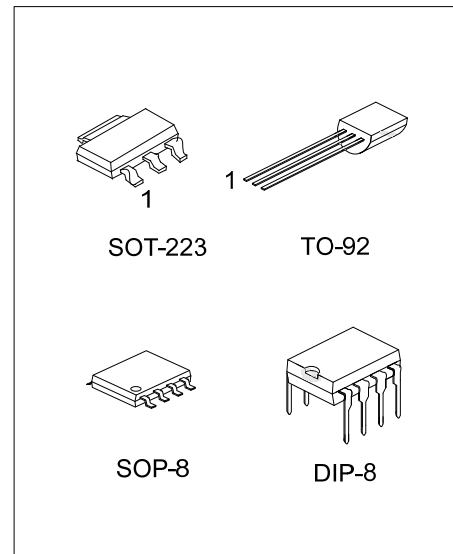

ORDERING INFORMATION

Ordering Number		Package	Pin assignment			Packing
Lead Free	Halogen Free		1	2	3	
LM2954L-xx-AA3-R	LM2954G-xx-AA3-R	SOT-223	I	G	O	Tape Reel
LM2954L-xx-AA3-A-R	LM2954G-xx-AA3-A-R	SOT-223	G	O	I	Tape Reel
LM2954L-xx-D08-T	LM2954G-xx-D08-T	DIP-8	refer to Pin Configurations			Tube
LM2954L-xx-S08-R	LM2954G-xx-S08-R	SOP-8	refer to Pin Configurations			Tape Reel
LM2954L-xx-T92-B	LM2954G-xx-T92-B	TO-92	O	G	I	Tape Box
LM2954L-xx-T92-K	LM2954G-xx-T92-K	TO-92	O	G	I	Bulk

Note: Pin assignment: I: V_{IN} O: V_{OUT} G: GND

<p>LM2954G-xx-AA3-R</p>	<p>(1) B: Tape Box, K: Bulk, R: Tape Reel, T: Tube</p> <p>(2) AA3: SOT-223, D08: DIP-08, S08: SOP-8, T92: TO-92</p> <p>(3) xx: refet to MARKING INFORMATION</p> <p>(4) G: Halogen Free and Lead Free, L: Lead Free</p>
-------------------------	--

LM2954

LINEAR INTEGRATED CIRCUIT

MARKING INFORMATION

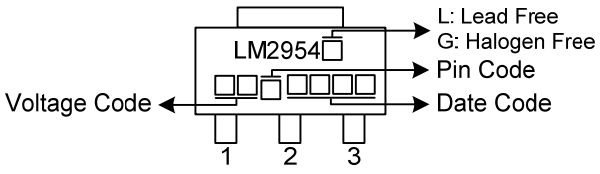
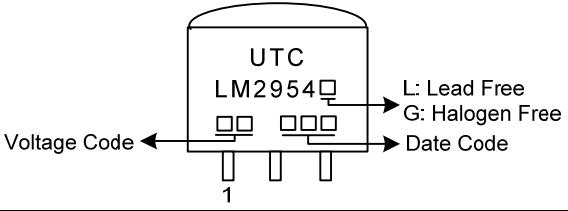
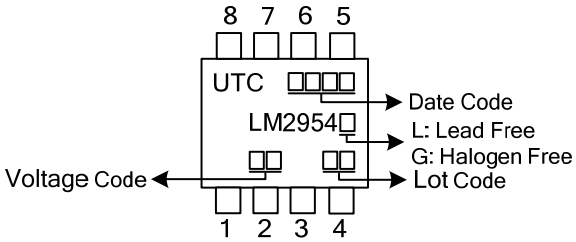
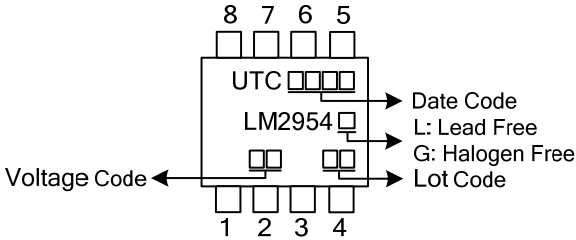
PACKAGE	VOLTAGE CODE	MARKING
SOT-223	33:3.3V 50:5.0V	 <p>Diagram of SOT-223 package marking. The package is a small surface-mount component with three pins labeled 1, 2, and 3. Markings include 'LM2954', a 'Voltage Code' (two characters), 'L: Lead Free', 'G: Halogen Free', 'Pin Code', and 'Date Code'.</p>
TO-92	33:3.3V 50:5.0V	 <p>Diagram of TO-92 package marking. The package is a small through-hole component with three pins, the first labeled 1. Markings include 'UTC', 'LM2954', a 'Voltage Code' (two characters), 'L: Lead Free', 'G: Halogen Free', and 'Date Code'.</p>
DIP-8	33:3.3V 50:5.0V AD:ADJ	 <p>Diagram of DIP-8 package marking. The package is an 8-pin through-hole component with pins labeled 1 through 8. Markings include 'UTC', 'LM2954', a 'Voltage Code' (two characters), 'Date Code', 'L: Lead Free', 'G: Halogen Free', and 'Lot Code'.</p>
SOP-8		 <p>Diagram of SOP-8 package marking. The package is an 8-pin surface-mount component with pins labeled 1 through 4. Markings include 'UTC', 'LM2954', a 'Voltage Code' (two characters), 'Date Code', 'L: Lead Free', 'G: Halogen Free', and 'Lot Code'.</p>

■ PIN CONFIGURATIONS

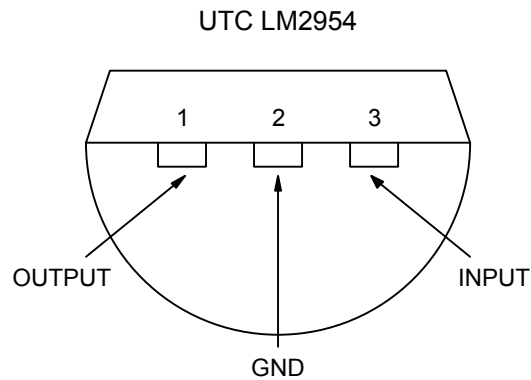

TO-92 Plastic Package Bottom View

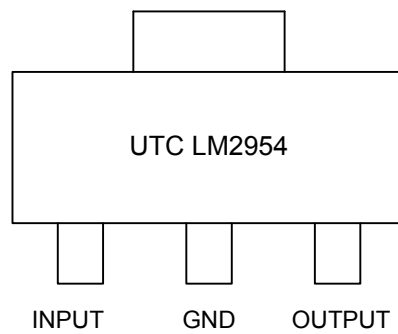

SOT-223 Package

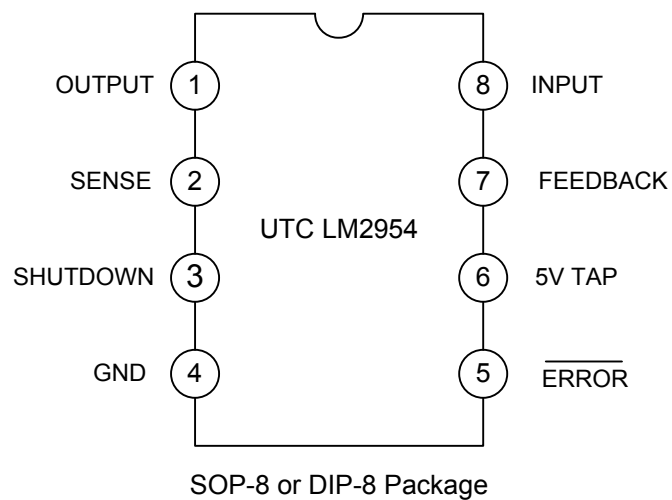

■ BLOCK DIAGRAM

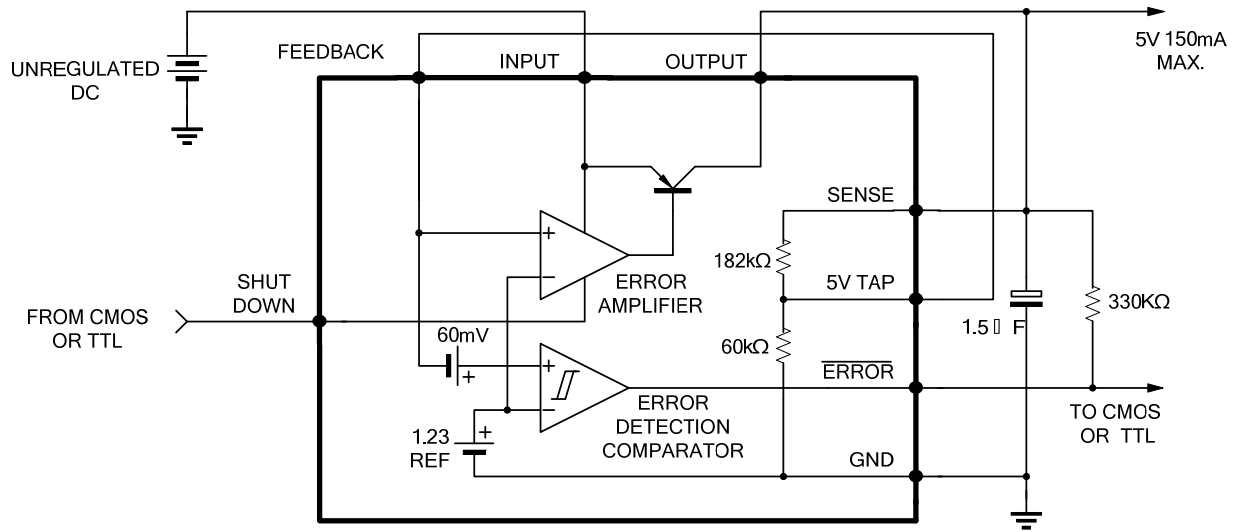

■ ABSOLUTE MAXIMUM RATINGS

PARAMETER	SYMBOL	VALUE	UNIT
Supply Voltage	V_{CC}	-0.3 ~ 28	V
Feedback Voltage	V_{FB}	-1.5 ~ 28	V
Shutdown Voltage	V_{SHDN}	-0.3 ~ 28	V
Comparator Output Voltage	V_{OUT}	-0.3 ~ 28	V
Junction Temperature	T_J	+125	°C
Operating Temperature	T_{OPR}	-40 ~ +85	°C
Storage temperature	T_{STG}	-40 ~ +150	°C

Notes: 1. Absolute maximum ratings are those values beyond which the device which the device could be permanently damaged. Absolute maximum ratings are stress ratings only and functional device operation is not implied.

2. The device is guaranteed to meet performance specification within 0°C~+70°C operating temperature range and assured by design from -20°C~+85°C, characteristic and correlation with static process control.

■ ELECTRICAL CHARACTERISTICS ($T_J=25^\circ\text{C}$, $V_{IN}=6\text{V}$, $I_L=100\mu\text{A}$, $C_L=1\mu\text{F}$, unless otherwise specified)

PARAMETER	SYMBOL	TEST CONDITIONS	MIN.	TYP.	MAX.	UNIT
Output Voltage	V_{OUT}	$T_J=25^\circ\text{C}$	3.23	3.3	3.37	V
			4.90	5.0	5.10	
Output Voltage Temperature Coefficient	$T_C V_O$		20		100	ppm/°C
Line Regulation	ΔV_{OUT}	$6\text{V} \leq V_{IN} \leq 28\text{V}$		0.1	0.2	%
Load Regulation	ΔV_{OUT}	$100\mu\text{A} \leq I_L \leq 300\text{mA}$		0.2	0.5	
Dropout Voltage	V_D	$I_L=100\text{mA}$			400	mV
		$I_L=200\text{mA}$ (Note 2)	380	450	600	
Ground Current	IGND	$I_L=100\mu\text{A}$		0.12	0.23	mA
		$I_L=200\mu\text{A}$		12	14	
Dropout Ground Current	I_D	$V_{IN}=4.5\text{V}$, $I_L=100\mu\text{A}$		560	650	μA
Current Limit	I_{LIMIT}	$V_{OUT}=0$	300			mA
Output Noise (10Hz to 100KHz)	e_N	$C_L=1\mu\text{F}$			430	μV
		$C_L=200\mu\text{F}$			160	
		$C_L=3.3\mu\text{F}$			100	

■ ELECTRICAL CHARACTERISTICS(Cont.)

LM2954-ADJ FOR 8-PIN VERSION ONLY

PARAMETER	SYMBOL	TEST CONDITIONS	MIN	TYP	MAX	UNIT
Reference Voltage	V_{REF}		1.22	1.235	1.25	V
Reference Voltage	V_{REF}	$V_{REF} \leq V_{OUT} \leq (V_{IN} - 1V)$, $2.3V \leq V_{IN} \leq 18V$, $100\mu A \leq I_L \leq 100mA$, $T_J \leq T_{JMAX}$	1.19		1.27	V
Feedback Pin Bias Current	$I_{B(FB)}$			20	40	nA
Reference Voltage Temperature Coefficient	$T_C V_{REF}$			50		ppm/°C
Feedback Bias Current Temperature Coefficient	$T_{C I_O}$			0.1		nA/°C
ERROR COMPARATOR						
Output Leakage Current	$I_{O(LEAK)}$	$V_{OH} = 28V$			1	μA
Output Low Voltage	V_{OL}	$V_{IN} = 4.5V$, $I_{OL} = 400\mu A$			250	mV
Upper Threshold Voltage	$V_{THD(UP)}$	(Note 3)	3.2			% V_{OUT}
Lower Threshold Voltage	$V_{THD(LOW)}$	(Note 3)			7.6	% V_{OUT}
Hysteresis	V_{HYS}	(Note 3)		15		mV
SHUTDOWN INPUT						
Input Logic Voltage	$V_{I(LOG)}$	Low (Regulator ON)		1.3	0.70	V
		High (Regulator OFF)	2.0			
Shutdown Pin Input Current	$I_{I(SHDN)}$	$V_{SHDN} = 2.4V$		30	50	μA
		$V_{SHDN} = 28V$		450	600	μA
Regulator Output Current Shutdown	$I_{O(SHDN)}$	$V_{SHDN} \geq 2V$, $V_{IN} \leq 28V$, $V_{OUT} = 0$, Feedback pin tied to 5V Tap.		3	10	μA

Note: 1. Additional conditions for 8-pin versions are feedback tied to 5V Tap and Output tied to Output Sense ($V_{OUT} = 5V$) and $V_{SHDN} \leq 0.8V$.

2. Dropout voltage is defined as the input to output differential at which the output voltage drops 100mV below its nominal value measured at 1V differential.

3. Comparator thresholds are expressed in terms of percentage value of voltage output.

APPLICATION CIRCUIT (10A Low Dropout Regulator)

For 8 Pins

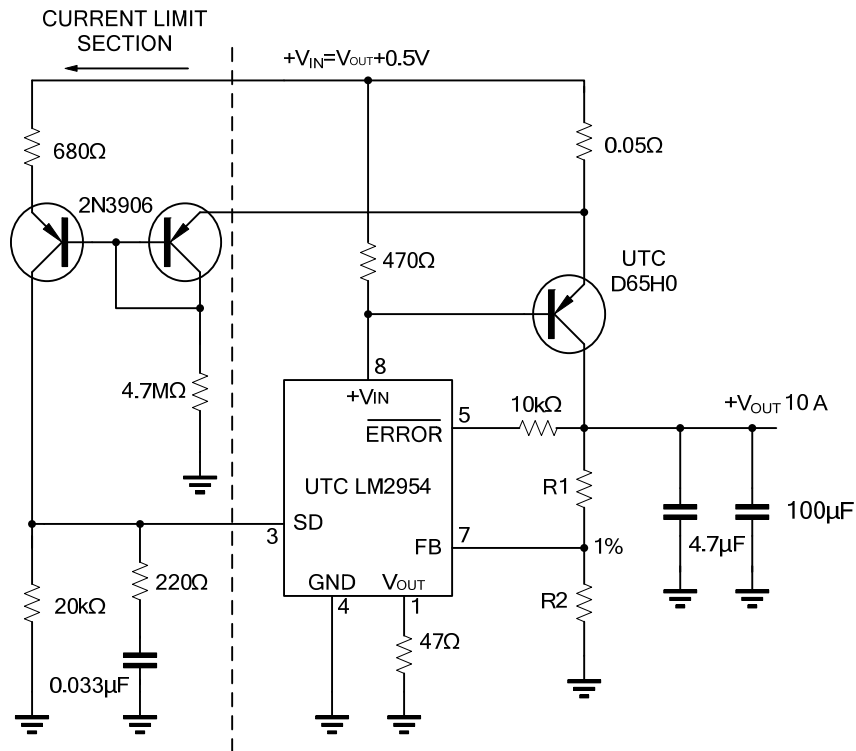

$$V_{OUT} = 1.23V * (1 + R1/R2)$$

For 5V output use internal resistors. Wire pin 6 to 7 and wire pin 2 to +Vout

For 3 Pins

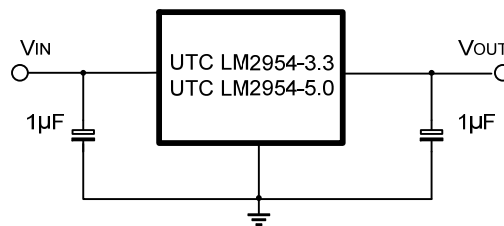

UTC assumes no responsibility for equipment failures that result from using products at values that exceed, even momentarily, rated values (such as maximum ratings, operating condition ranges, or other parameters) listed in products specifications of any and all UTC products described or contained herein. UTC products are not designed for use in life support appliances, devices or systems where malfunction of these products can be reasonably expected to result in personal injury. Reproduction in whole or in part is prohibited without the prior written consent of the copyright owner. UTC reserves the right to make changes to information published in this document, including without limitation specifications and product descriptions, at any time and without notice. This document supersedes and replaces all information supplied prior to the publication hereof.