

Description

A resonant inductive position sensor for measuring over a full 360° of rotation. Works with CambridgeIC's Central Tracking Unit (CTU) family of single chip processors to provide high-quality position data to a host device.

The sensor is available as a blueprint in Gerber format, to enable integration with a customer's own PCB. It is also available as assembled sensors for evaluation, customer prototyping and low-volume production.

Features

- Simple non-contact target
- Sensor coil pattern < 25mm dia.
- Full absolute sensing over 360°
- Operates up to 5mm gap
- Standard 4-layer PCB process
- Highly repeatable

Performance

- $\pm 0.5^\circ$ ($\pm 0.14\%$) Absolute Error at gap 1.5mm
- $\pm 1^\circ$ at Radial Misalignment 1mm, gap 0.5...2.5mm
- $\Delta < \pm 0.18^\circ$ ($\pm 0.05\%$) $-40^\circ\text{C} \dots 85^\circ\text{C}$, $\leq 3.5\text{mm}$ Gap

Product identification	
Part no.	Description
013-0006	Assembled sensor
013-6001	300mm ribbon connector
013-1005	Compatible target
010-0002	Sensor Blueprint

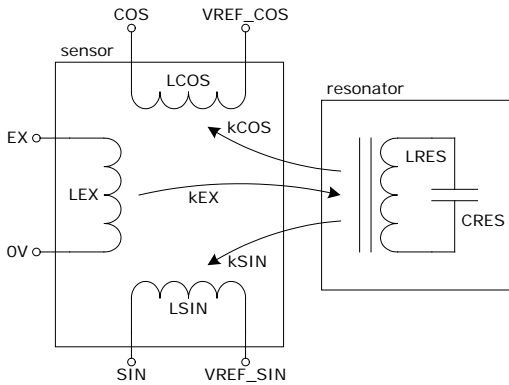

Figure 1 equivalent circuit

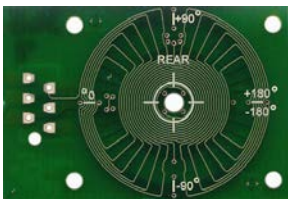

Figure 2 assembled sensor 013-0006, approximate actual size, viewed from rear

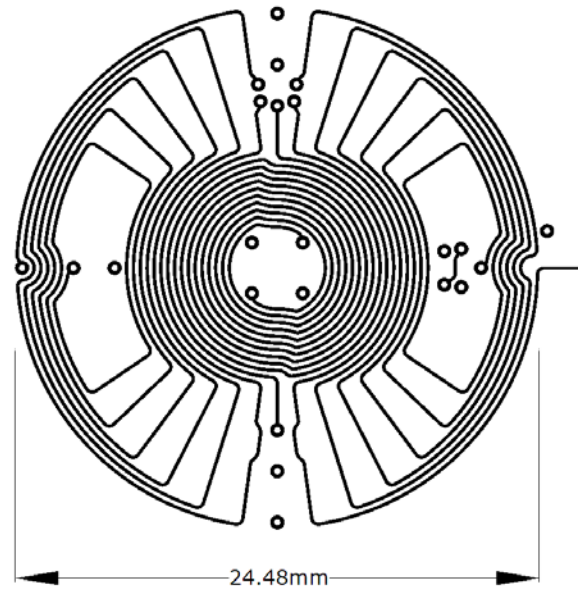

Figure 3: layer 1 sensor pattern

Applications

- Motion control
- Actuator position feedback
- Precision front panel controls
- Valve position sensing
- Industrial potentiometer replacement
- RVDT replacement
- Absolute optical encoder replacement

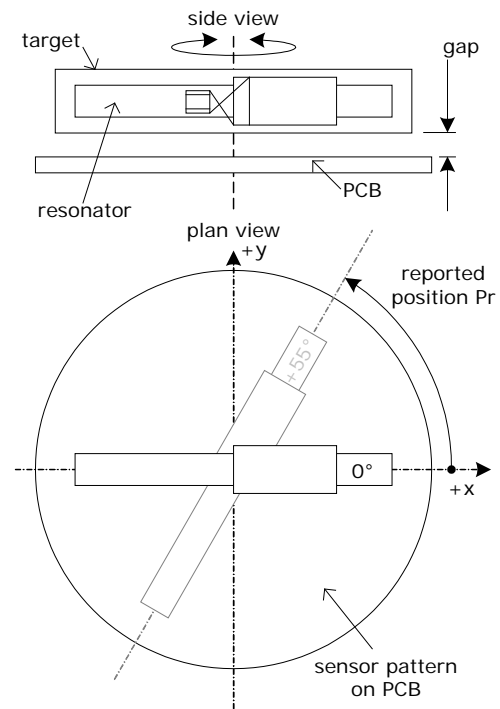

Figure 4 sensor measures resonator angle

1 Assembled Sensor 013-0006

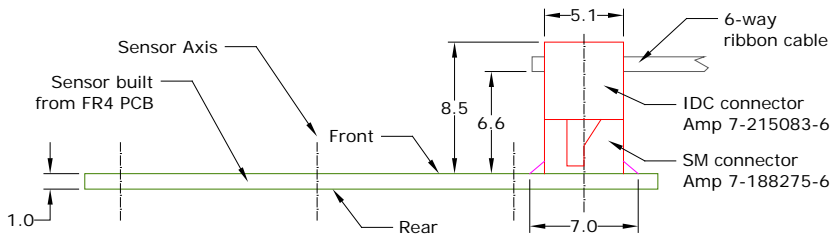
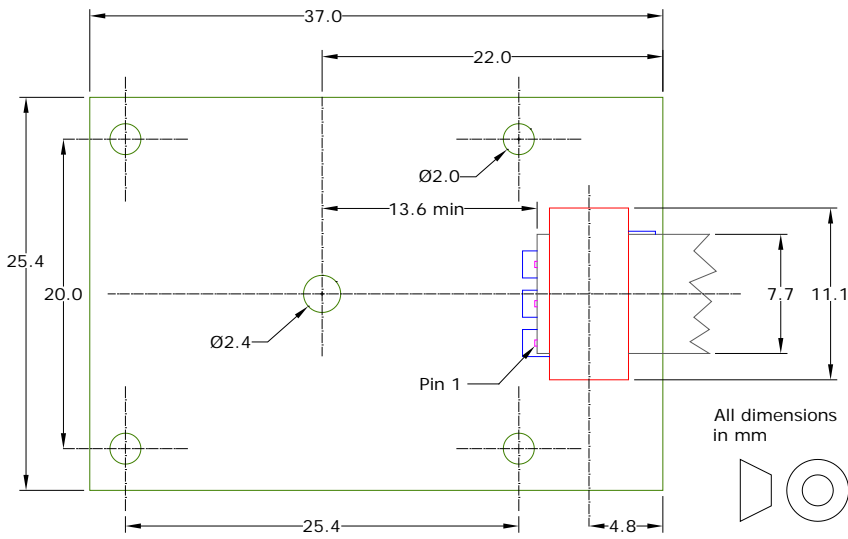

Figure 5 sensor board part number 013-0006 mated with connector 013-6001

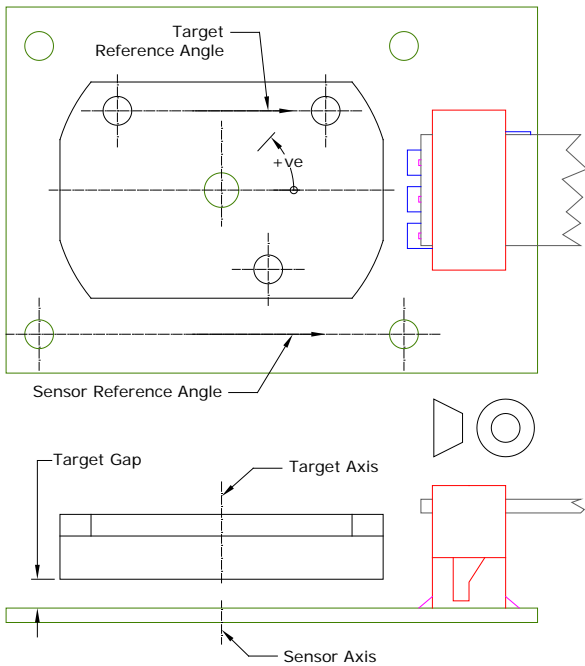

Figure 6 Use with Target 013-1005 at Front, 0°

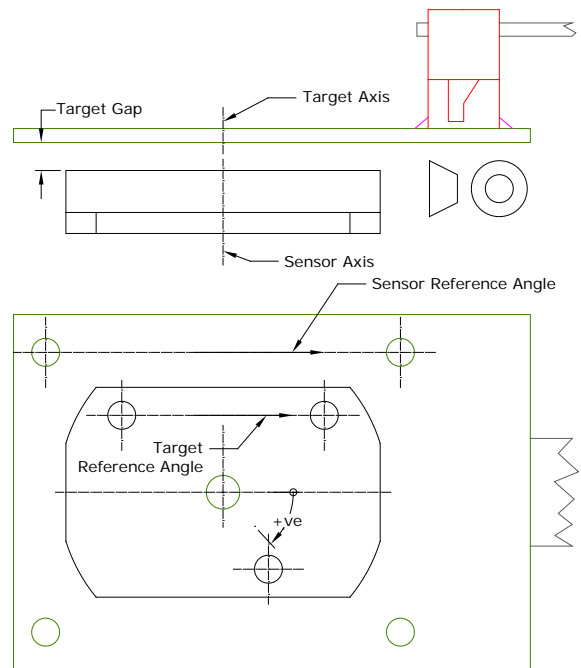

Figure 7 Use with Target 013-1005 at Rear, 0°

2 Performance

This section illustrates performance of the 360° position sensor. Figures are representative of assembled sensors available from CambridgeIC (as described in section 1) and of sensors built according to CambridgeIC’s blueprint (section 3). Measurements are taken with a typical target (part number 013-1005) and CTU Development Board (part number 013-5006 using CambridgeIC’s CAM204A chip).

2.1 Transfer Function and Performance Metrics

The sensor is connected to a CTU chip which reports position as a 16-bit signed integer, here denoted *CtuReportedPositionI16*. The sensor span is 360°, so the reported position may be converted to degrees using:

$$ReportedDegrees = \frac{CtuReportedPositionI16}{65536} \times 360^\circ$$

Equation 1

The actual angle is defined relative to reference holes on the sensor and target, as illustrated in Figure 6 or Figure 7 so that:

$$ActualDegrees = TargetReferenceAngle - SensorReferenceAngle$$

Equation 2

Absolute Error is the difference between these two:

$$AbsoluteError = ReportedDegrees - ActualDegrees$$

Equation 3

According to this definition, Absolute Error includes the error in angular alignment between the resonator inside the target and the features used to define the Target Reference Angle (two mounting holes in the case of target 013-1005). This document concerns the sensor alone, and performance is quoted excluding this Target Offset Angle.

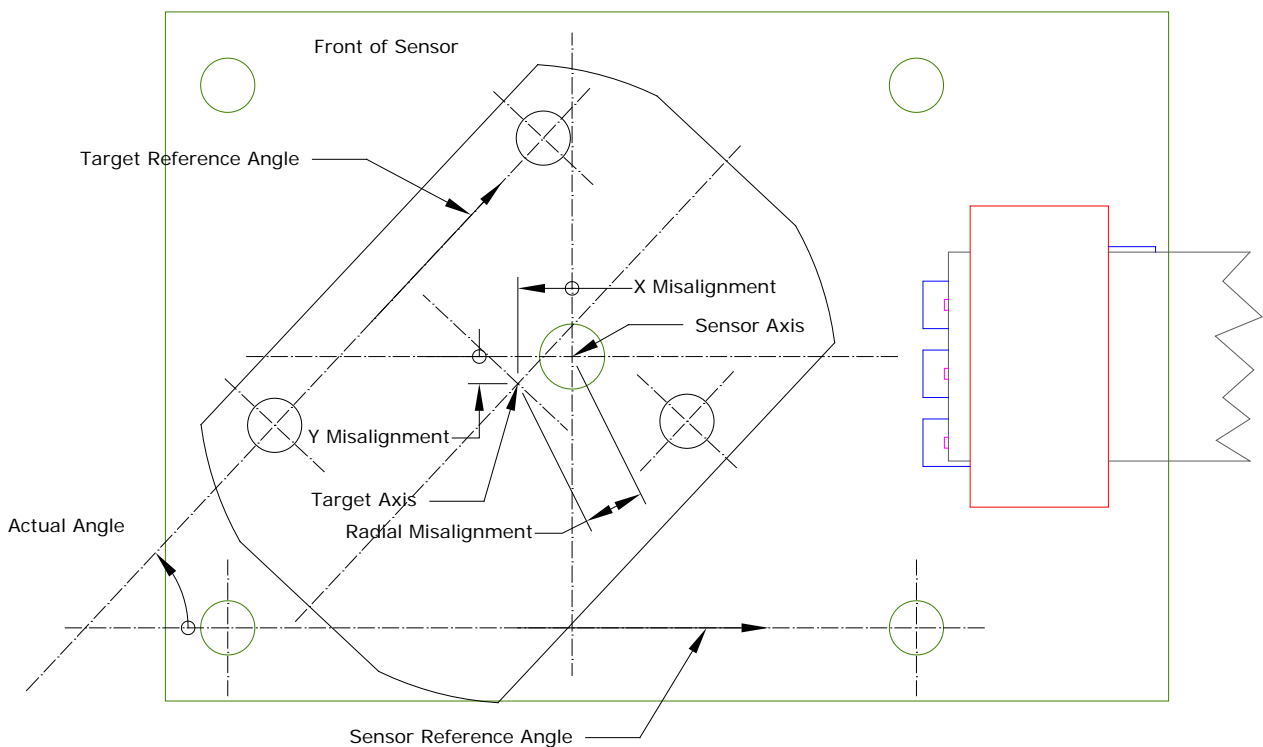

Figure 8 Definition of X, Y and Radial Misalignment, and Actual Angle

The Target Axis and Sensor Axis should coincide for best performance. Figure 8 defines X, Y and Radial Misalignment, to describe cases where there is an error in alignment. (Both X and Y Misalignments are shown negative).

2.2 Absolute Error

Figure 9 illustrates how Absolute Error depends on Target Gap and Radial Misalignment, for a typical sensor in free space:

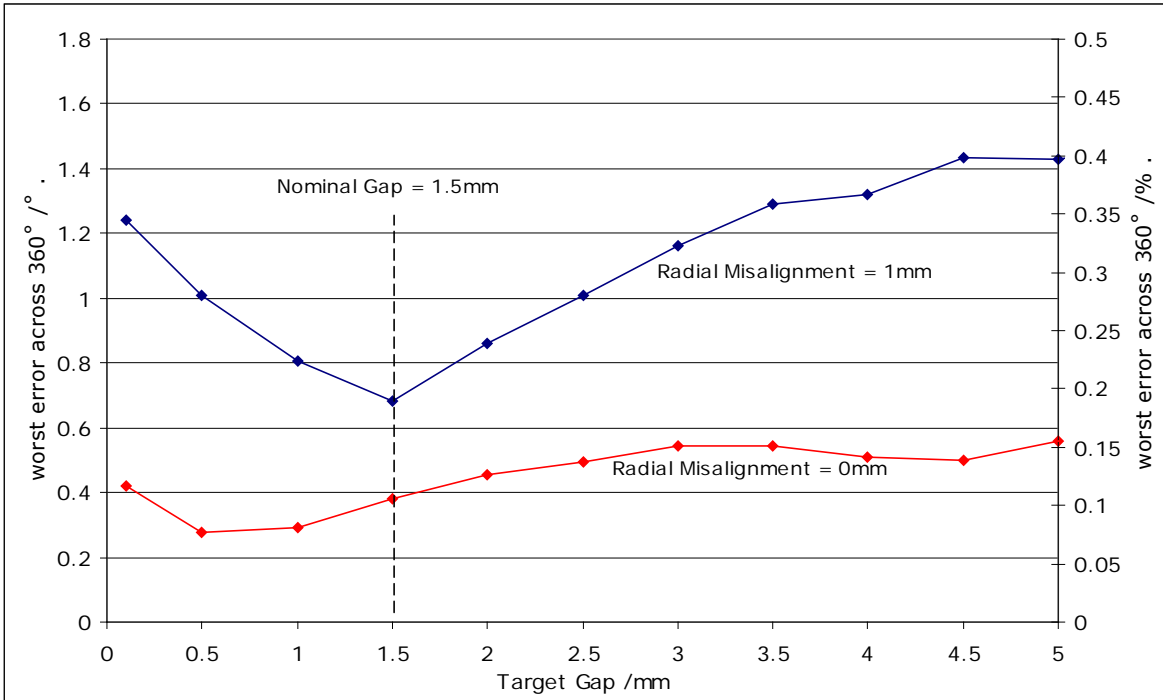

Figure 9 Absolute Error against Target Gap, misaligned by 0mm and 1mm

2.3 Sensor to Sensor Repeatability

Figure 10 is a plot of Absolute Error against Actual Angle for 15 different sensors. These include representative samples built by 2 different manufacturers.

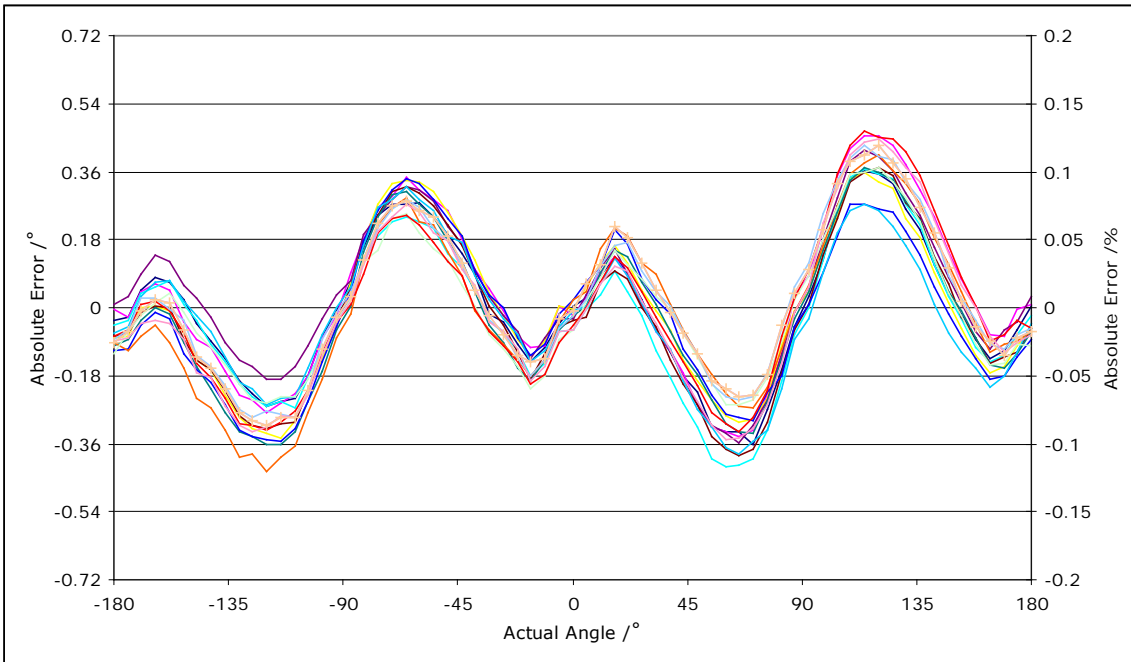

Figure 10 Absolute Error at 1.5mm Target Gap, 15 different sensors

2.4 Temperature Stability

Resonant inductive position sensors derive their precision from the printed geometry of a sensor board, which changes very little with temperature. Figure 11 and Figure 12 illustrate the effect of temperature on a typical sensor, target and CAM204A CTU chip combination. Measurements were taken at 3 different Actual Angles.

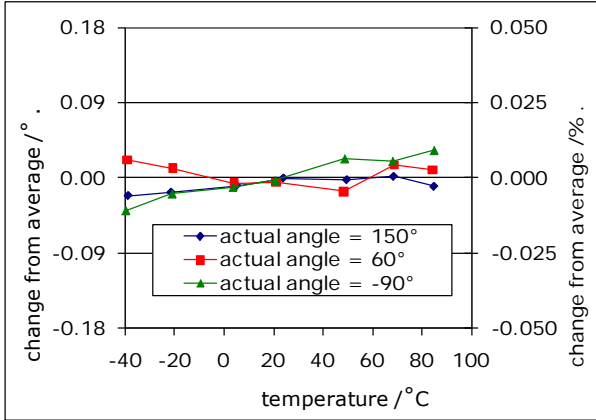

Figure 11 Target Gap 1.5mm

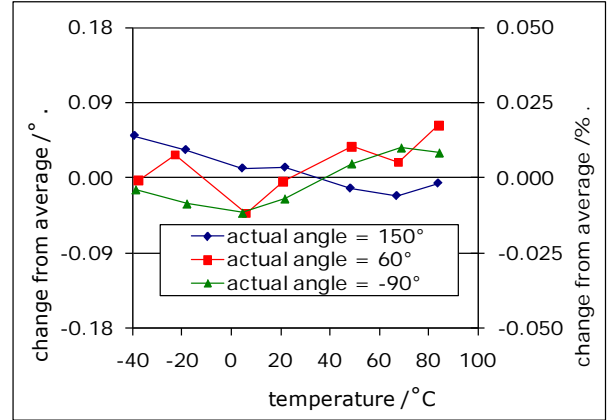

Figure 12 Target Gap 3.5mm

2.5 Amplitude

Amplitude is a measure of inductive signal coupling between the sensor and target. Higher values are preferable since they result in better resolution when the sensor is used with a CTU chip. Figure 14 illustrates how Amplitude changes with Target Gap for a typical sensor.

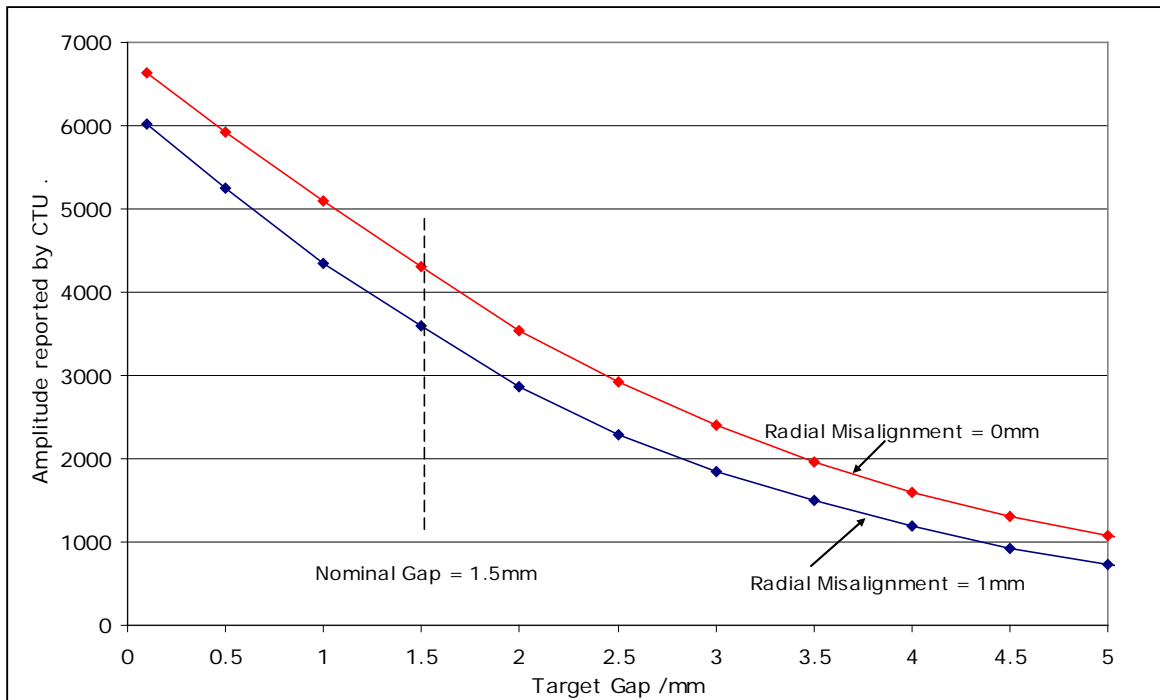

Figure 13 Amplitude reported by CTU against Target Gap, misaligned by 0mm and 1mm, free space

2.6 Metal Behind Sensor

The sensor can be installed with metal behind (as drawn in Figure 13), providing there is sufficient gap to the metal (Table 1). Changes in the gap to metal should be avoided for best linearity: it is preferable for the metal to be flat and parallel to the sensor.

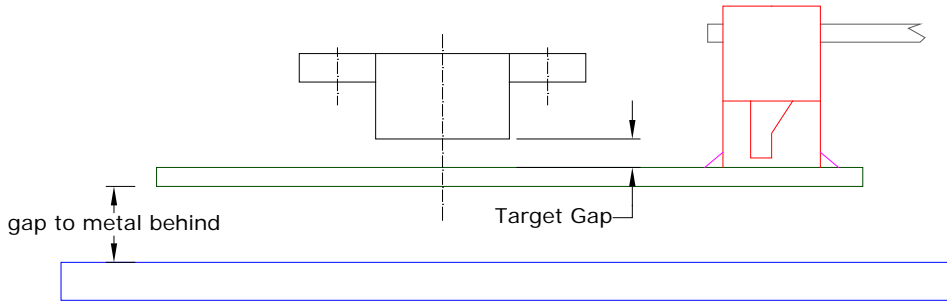

Figure 14 metal behind sensor

Table 1

Type of metal	Gap to metal behind	
	Absolute Minimum	Recommended minimum
Aluminium, copper, brass sheet (>0.1mm thick)	2mm	4mm
Stainless steel (austenitic)	2.5mm	5mm
Mild steel, or aluminium or copper foil (10 – 50µm)	3mm	6mm

The main effects of metal behind the sensors are to reduce Amplitude and to modify the target’s resonant frequency slightly. The CTU automatically tunes to the target’s frequency, so the reduction in amplitude is normally the main concern. Aluminium has the least effect on Amplitude (Figure 14). A reduction in Amplitude degrades resolution; please see the CTU datasheet for data.

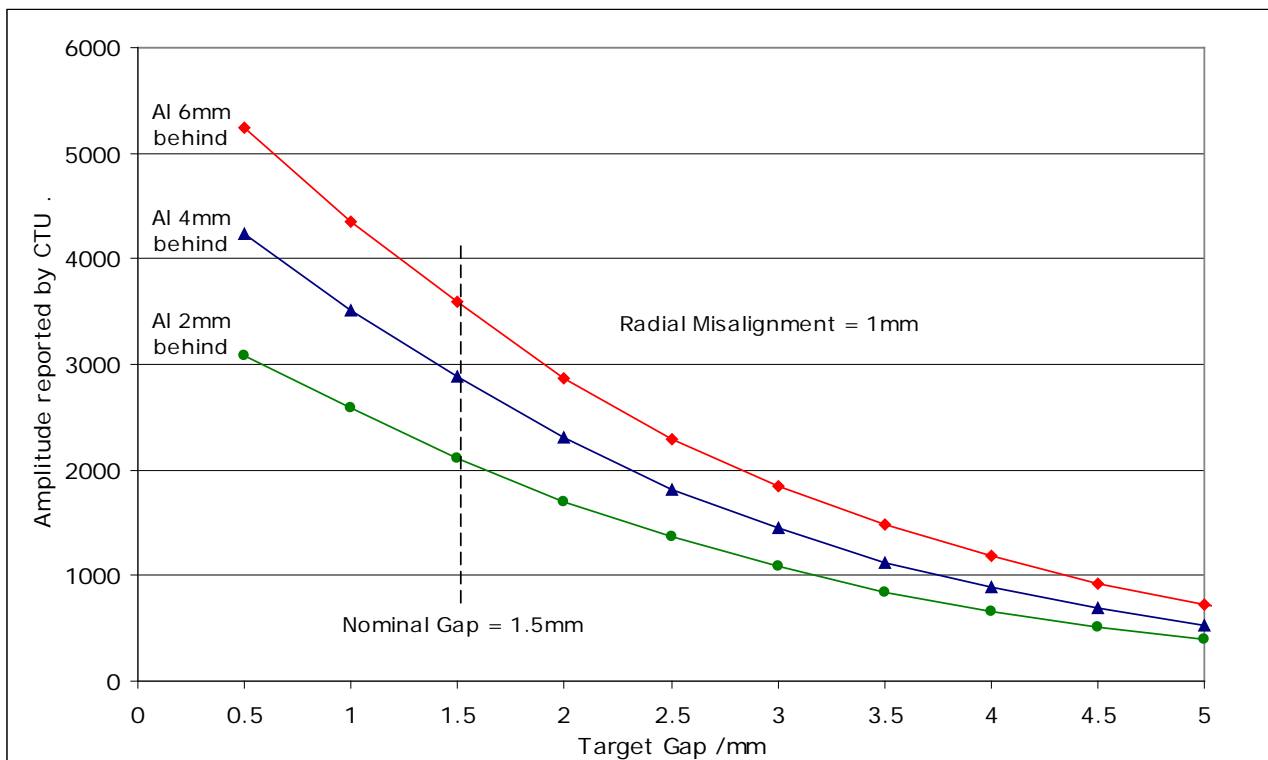

Figure 15 Reported Amplitude with an Aluminium sheet behind sensor

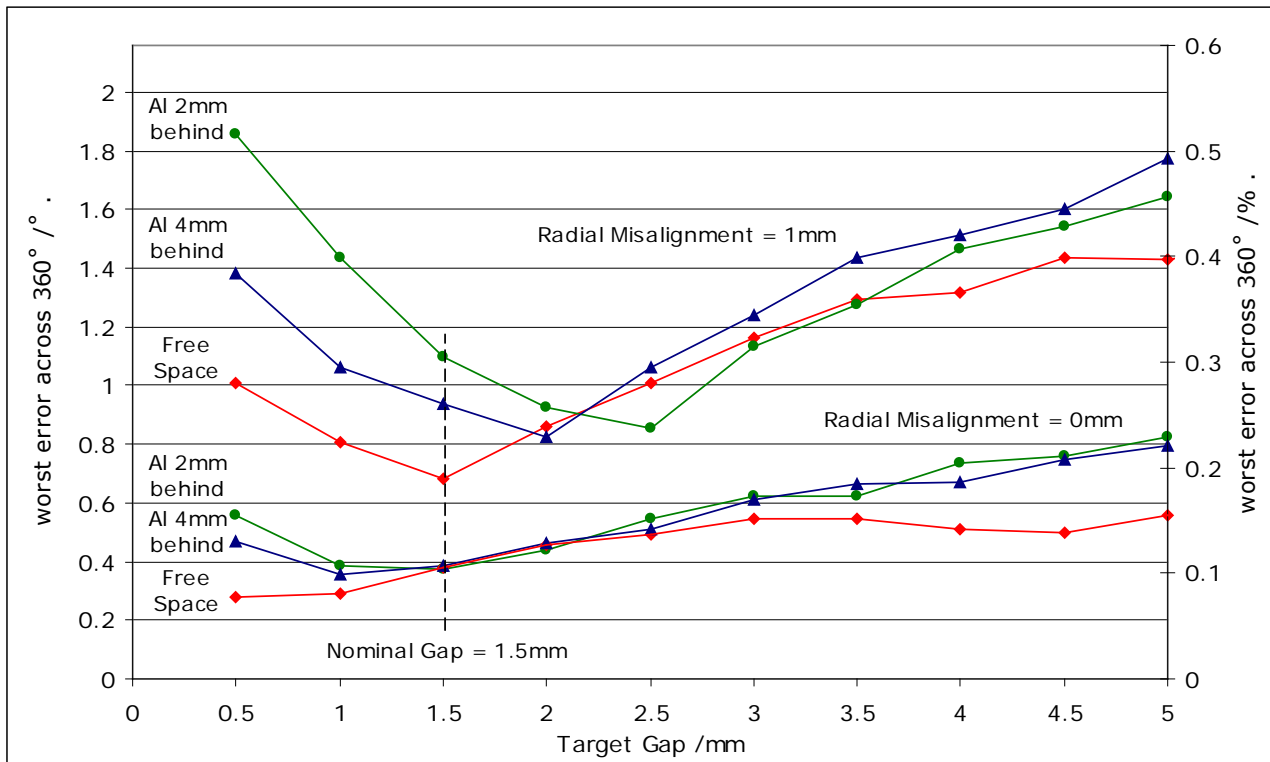

Figure 16 Absolute Error against gap with an Aluminium sheet behind sensor

3 Sensor Blueprint 010-0002

3.1 Purpose

A sensor blueprint comprises Gerber (RS274-X) data defining the pattern of conductors required to build the sensor onto a PCB. A customer may build their own sensors for use with CambridgeIC’s CTU family of processors, either as stand-alone sensors or combined with their own circuitry.

3.2 Fabrication Technology

The sensor blueprint is fabricated on a 4-layer PCB. The PCB copper thickness should be as large as convenient, since this keeps resistances low and hence power consumption down.

Table 2

Copper thickness	oz	µm
Minimum	0.8	28
Recommended	≥1	≥35
Ideal	2	70

3.3 PCB Design Parameters

Table 3

PCB Design Rules	Minimum values used	
	mm	inches
Track width	0.15	0.006
Gap between tracks	0.15	0.006
Via land outer diameter	0.64	0.025
Drill hole diameter	0.3	0.012

3.4 PCB Integration

Figure 16 illustrates the extent of the copper pattern required to build the sensor on a PCB. The circular area is the sensor itself, with coil connections shown to the right. The coil pattern may be rotated or flipped to fit a customer’s assembly, in which case the position reported by the CTU will be transformed accordingly.

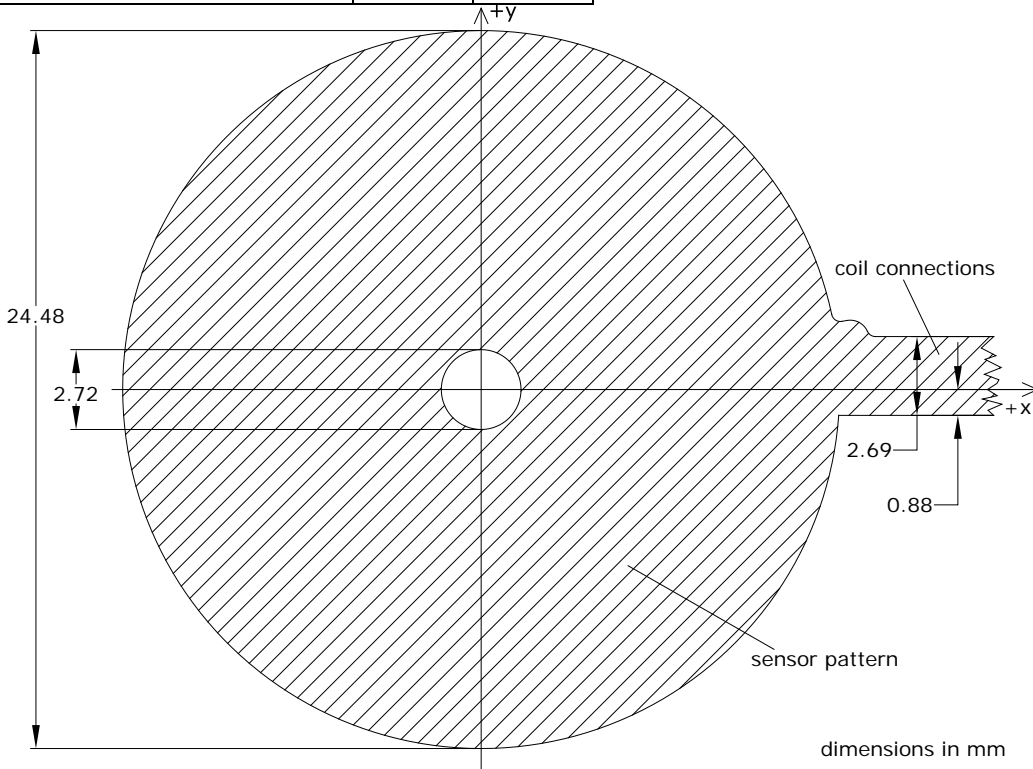

Figure 17 copper extents

3.5 Trace Connections

There are three pairs of tracks, which should be connected to the respective CTU circuit connections with the minimum practical trace lengths. The excitation pair should have minimum resistance, preferably by using traces 0.5mm wide or more.

Tracks are routed in pairs, and each member of a pair should follow the same path as the other, on different and preferably adjacent layers, to minimise errors due to unbalanced loops. VREF_SIN and VREF_COS should, where possible, be connected to the CTU circuit’s VREF node as close as possible to the CTU circuit.

4 Environmental

Assembled sensor part number 013-0006 conforms to the following environmental specifications:

Item	Value	Comments
Minimum operating temperature	-40°C	Limited by specification of connector
Maximum operating temperature	105°C	
Maximum operating humidity	95%	Non-condensing

Sensors built to Sensor Blueprints can operate in more extreme conditions by choice of materials and encapsulation.

5 Document History

Revision	Date	Comments
A	15 July 2008	First draft
B	5 March 2009	Moved principle of operation to separate document Updated mechanical drawings for target 013-1005
C	1 June 2009	Added metal integration data
0002	15 September 2009	Revised temperature data includes CTU chip
0003	10 December 2009	Revised sensor blueprint copper thickness
0004	19 January 2010	Updated logo and style
0005	29 January 2013	Corrected Sensor Blueprint part number
0006	13 February 2014	Added patent numbers

6 Contact Information

Cambridge Integrated Circuits Ltd
21 Sedley Taylor Road
Cambridge
CB2 8PW
UK

Tel: +44 (0) 1223 413500

info@cambridgeic.com

7 Legal

This document is © 2008-2014 Cambridge Integrated Circuits Ltd (CambridgeIC). It may not be reproduced, in whole or part, either in written or electronic form, without the consent of CambridgeIC. This document is subject to change without notice. It, and the products described in it ("Products"), are supplied on an as-is basis, and no warranty as to their suitability for any particular purpose is either made or implied. CambridgeIC will not accept any claim for damages as a result of the failure of the Products. The Products are not intended for use in medical applications, or other applications where their failure might reasonably be expected to result in personal injury. The publication of this document does not imply any license to use patents or other intellectual property rights.

The design of the sensor, comprising each of the patterned copper layers, drill locations, silk screens, assembly layers and board outline are protected by copyright.

The parts described in this datasheet are subject to the following patents: US8570028B2, GB2461448B. Other patents are pending.