



# TAOGLAS®



# Datasheet

**Part No:**  
CGGP.25.4.E.02

**Description:**  
GPS/GLONASS/Galileo Patch Antenna 25\*25\*4mm

**Features:**  
GPS/Galileo L1 and GLONASS G1 Operation  
1575.42MHz and 1602MHz Resonance  
Dimensions: 25\*25\*4mm  
Pin type Ceramic Patch Antenna  
Automotive TS16949 Production and Quality Approved  
RoHS & REACH Compliant

1. Introduction	3
2. Specifications	4
3. Antenna Characteristics	5
4. Antenna Radiation Pattern	7
5. Axial Ratio	10
6. Mechanical Drawing	11
7. PCB Footprint Recommendation	13
8. Antenna Integration Guide	14
9. Evaluation Board Mechanical Drawing	19
10. Packaging	20
<hr/>	
Changelog	21

Taoglas makes no warranties based on the accuracy or completeness of the contents of this document and reserves the right to make changes to specifications and product descriptions at any time without notice. Taoglas reserves all rights to this document and the information contained herein. Reproduction, use or disclosure to third parties without express permission is strictly prohibited.



## 1. Introduction



The CGGP.25.4.E.02 is a 25\*25\*4 mm embedded ceramic GPS/GLONASS/Galileo Patch antenna. It features a double resonance design at GPS/Galileo and GLONASS bands, 1575.42 MHz and 1602MHz respectively. This antenna has been tuned for a center position on a 70mm \*70mm ground plane. Return loss is -28dB at 1575.42MHz and -22dB at GLONASS. Overall, the antenna has greater than 60% efficiency.

For further optimization to customer specific device environments where positioning is off center or a different ground-plane size, custom tuned patch antennas can be supplied. For more information please contact your regional Taoglas customer support team.

## 2. Specifications

Electrical		
Application Bands	GPS/GALILEO	GLONASS
Operation Frequency	1575.42 ±1.023MHz	1602±5MHz
VSWR	1.8 max	
Efficiency	88.02%	88.63%
Peak Gain	5.39dBi	5.46dBi
Axial Ratio	~10	~9
Polarization	Linear	
Impedance	50 ohms	
Mechanical		
Ceramic Dimension	25x25x4 mm	
Pin Diameter	Ø0.9 mm	
Pin Length	2.4mm	
Weight	9.5g	
Environmental		
Operation Temperature	-40°C to 105°C	
Moisture Sensitivity	Level 3	

\* Antenna properties were measured with the antenna mounted on 70\*70mm Ground Plane

### 3. Antenna Characteristics

#### 3.1 Return Loss

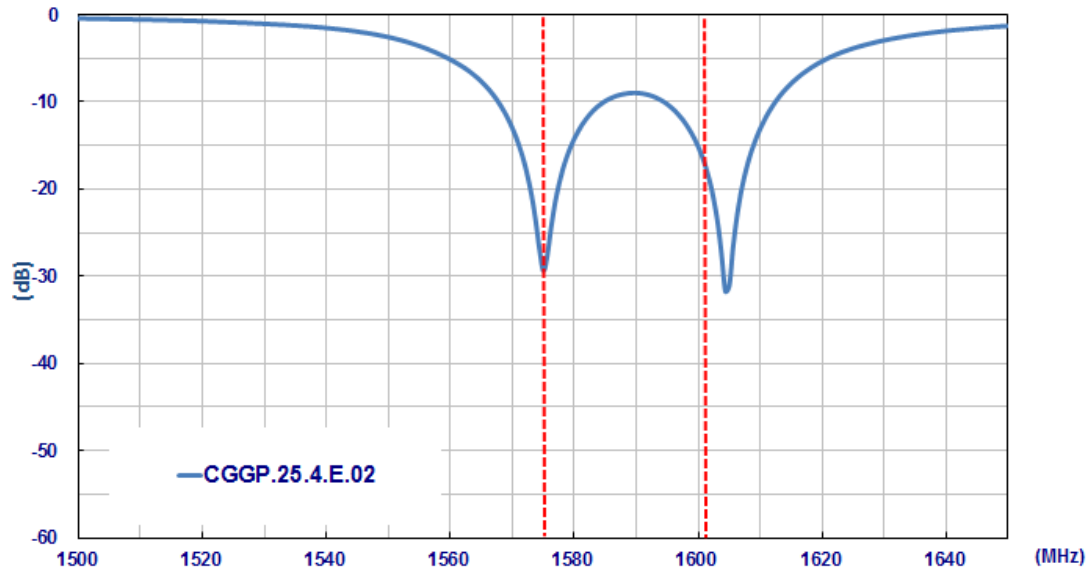

#### 3.2 Efficiency

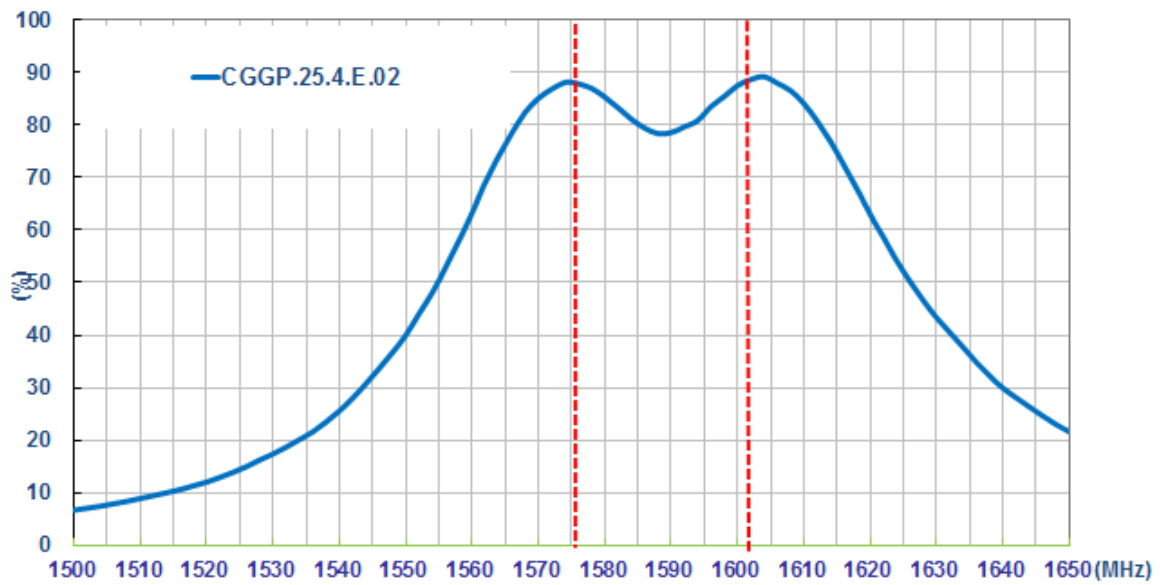

### 3.3 Average Gain

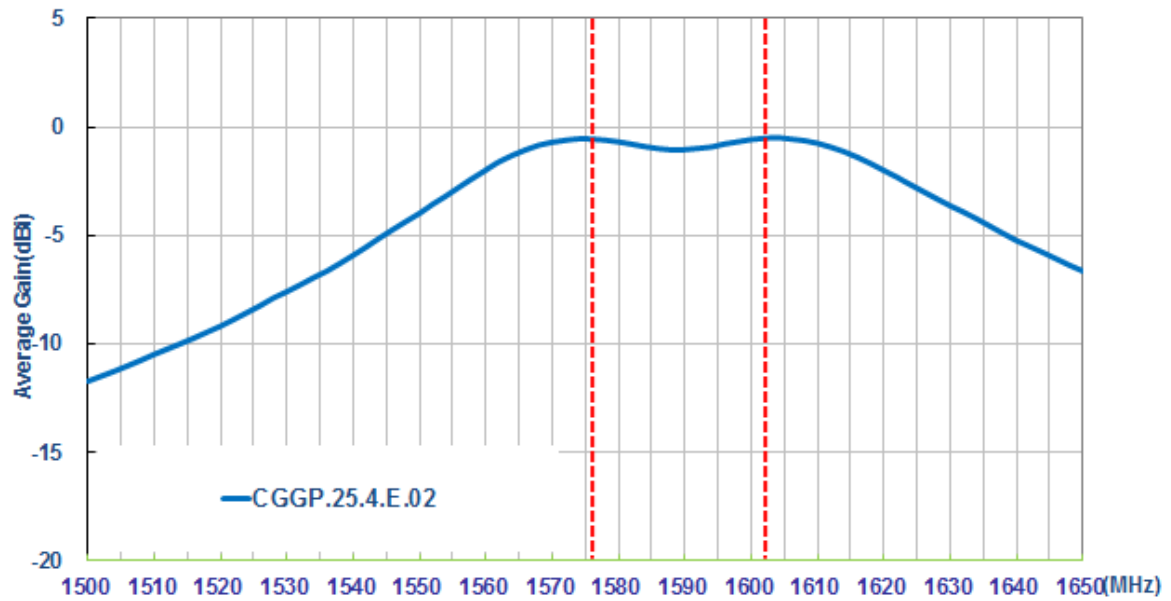

### 3.4 Peak Gain

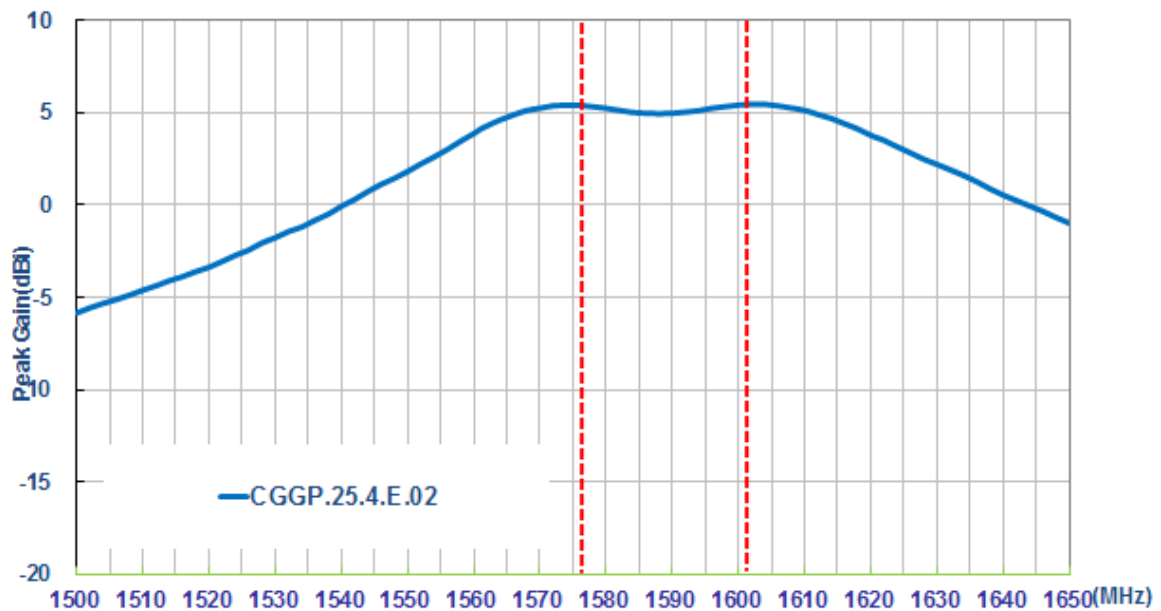

## 4. Antenna Radiation Pattern

### 4.1 Measurement Setup



## 4.2 2D Radiation Pattern

**XY Plane**

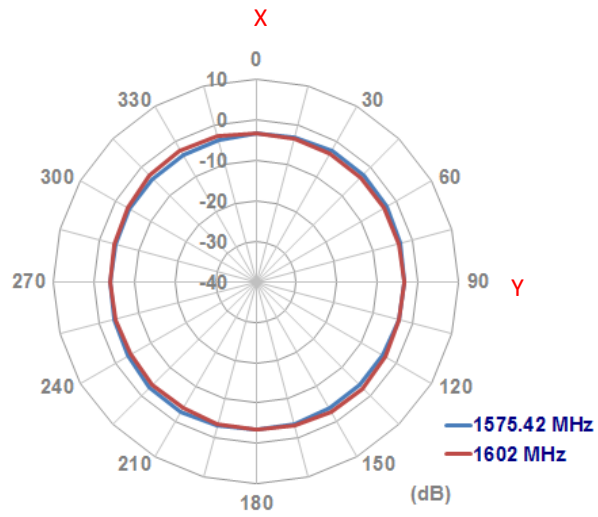

**XZ Plane**

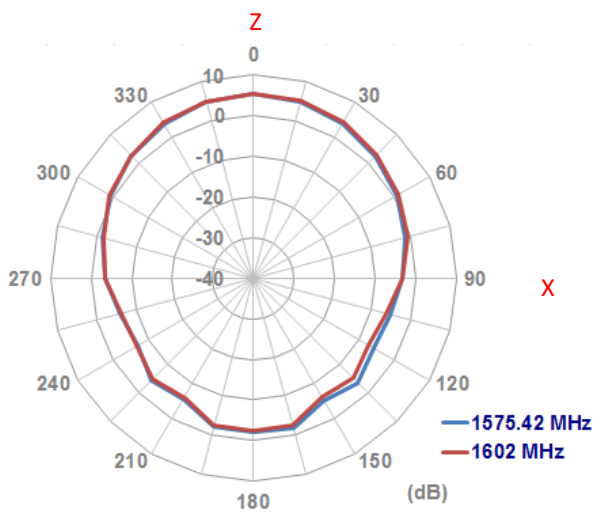

**YZ Plane**

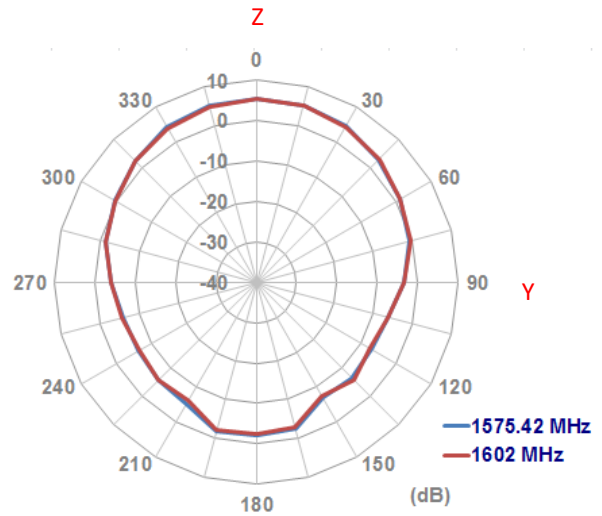



### 4.3 3D Radiation Pattern

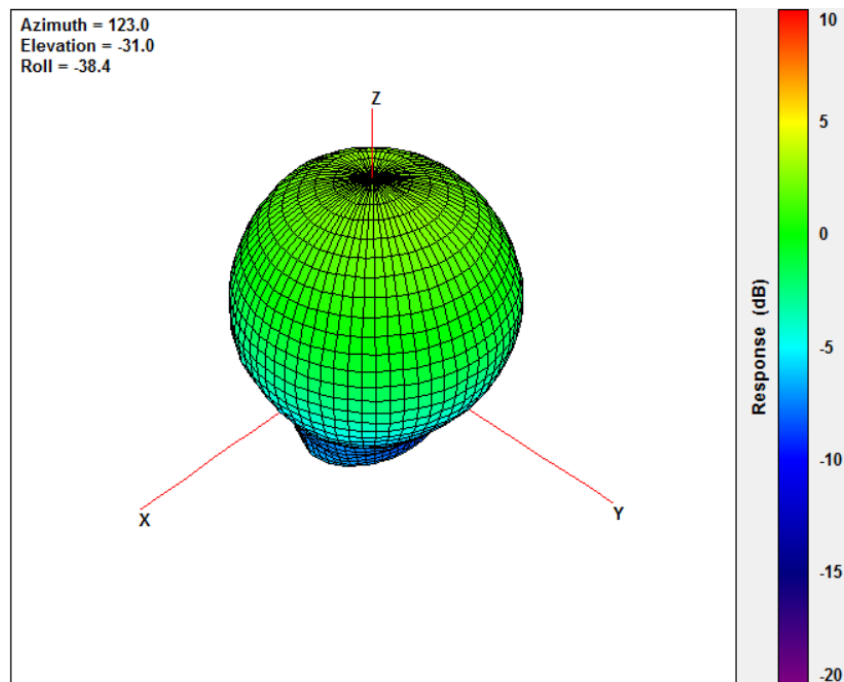

1575.42MHz

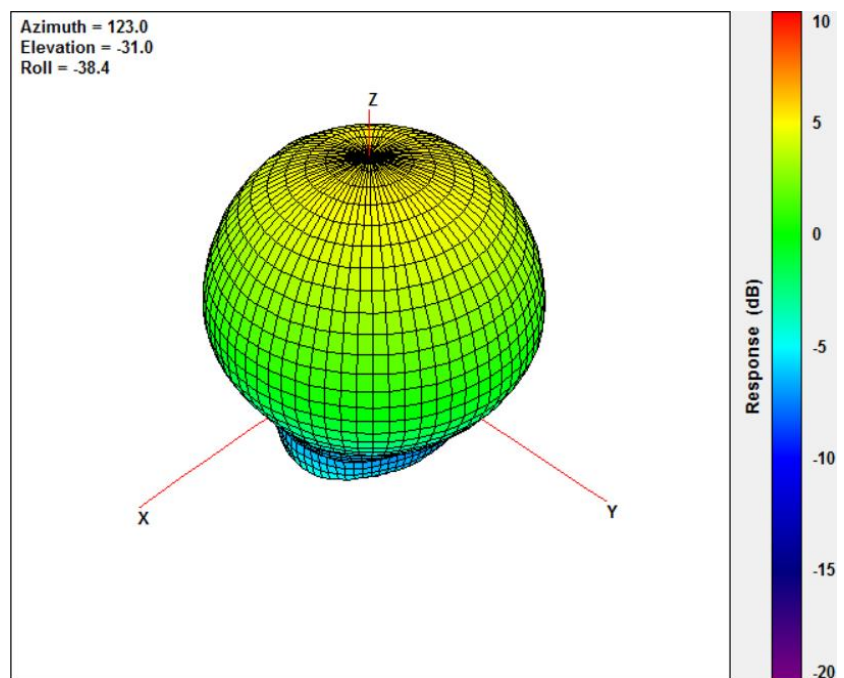

1602MHz

## 5. Axial Ratio

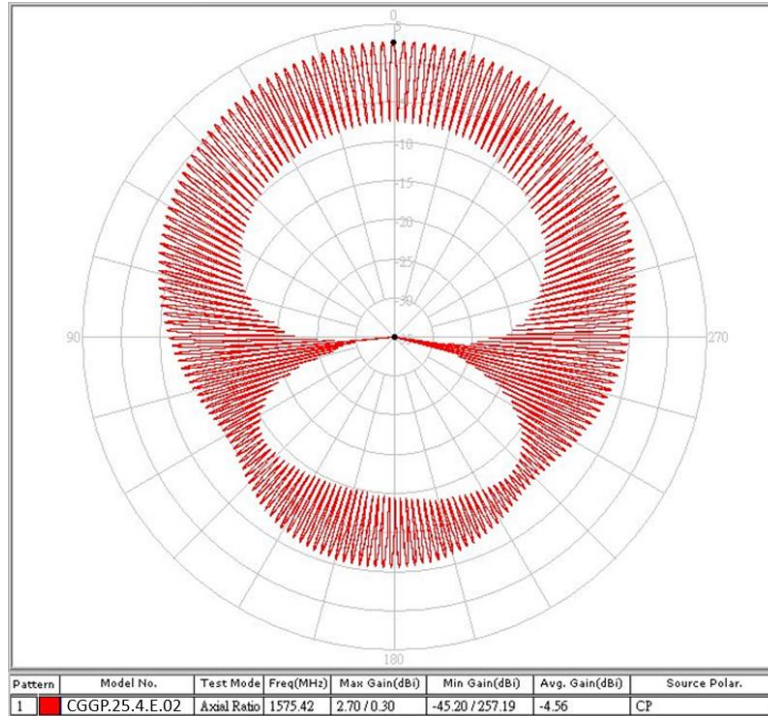

1575.42 MHz

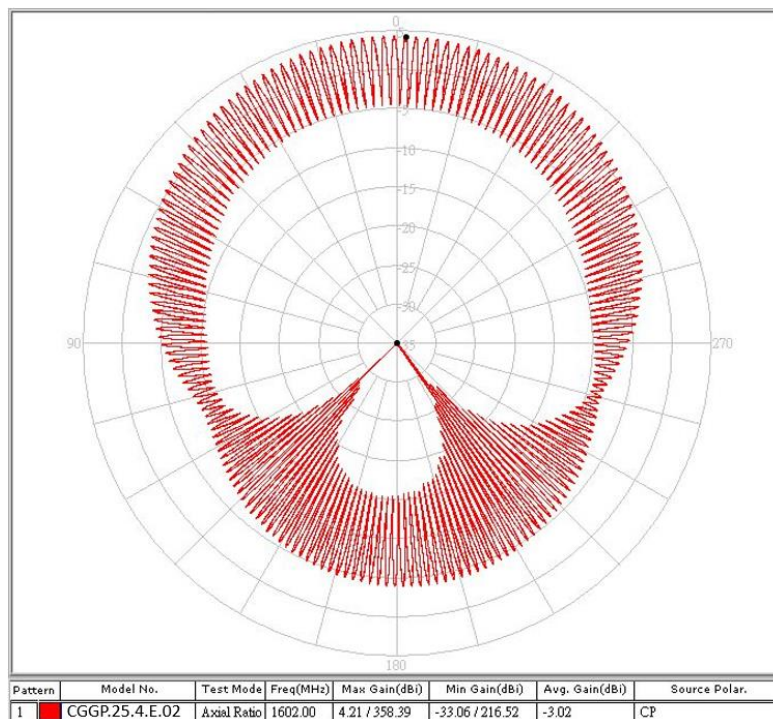

1602MHz

# 6. Mechanical Drawing (Unit: mm)

ISO NO.: EDW-18-8-0703

STATE: Release

NOTES: 1. Double sided adhesive area 2. Soldermask area

REV.	DESCRIPTION	ENG.	APPROVED	DATE
A	Initial Design	Eva	Paul	2018/09/06
B	Replace the new LOGO <del>EDW-18-8-259</del>	Bonnie	Haley	2019/04/08
C	EC-21-08-010	Mickey	Buluto	2021/03/02

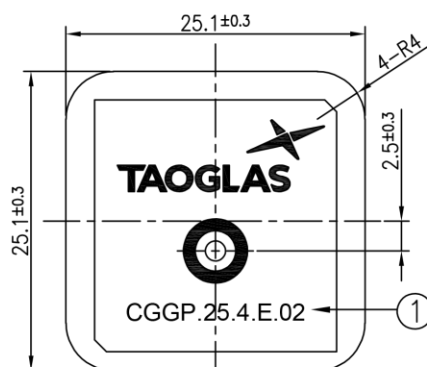

Top View

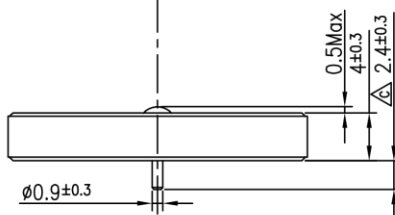

Side View

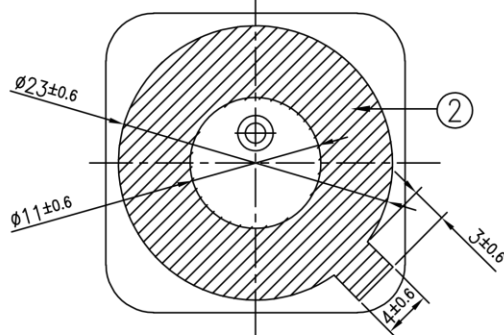

Bottom View

	Name	P/N	Material	Finish	QTY
1	Patch	001518H180000A	Ceramic	Clear	1
2	Double sided Adhesive	001518H180000A	NIITO 5015	White Liner	1

APPROVED BY: Wayne	TW Design Centre <small>This drawing and its inherent design concepts are property of Taoglas. Not to be copied or given to third parties without the written consent of Taoglas.</small>
CHECK BY: Aine	
DRAWN BY: Haley	
DATE: 2015/08/24	
UNLESS OTHERWISE SPECIFIED TOLERANCES ON: XX±0.5 X±0.3 XX±0.2 XX±0.1 XXX±0.05	TITLE : GPS/GLONASS Dual-Band Patch Antenna 25*25*4mm
THIRD ANGLE PROJECTION	PART NO. : CGGP.25.4.E.02
UNIT: mm	SCALE: 2:1
PAGES: 1/1	REV. C

## Adhesive Thickness

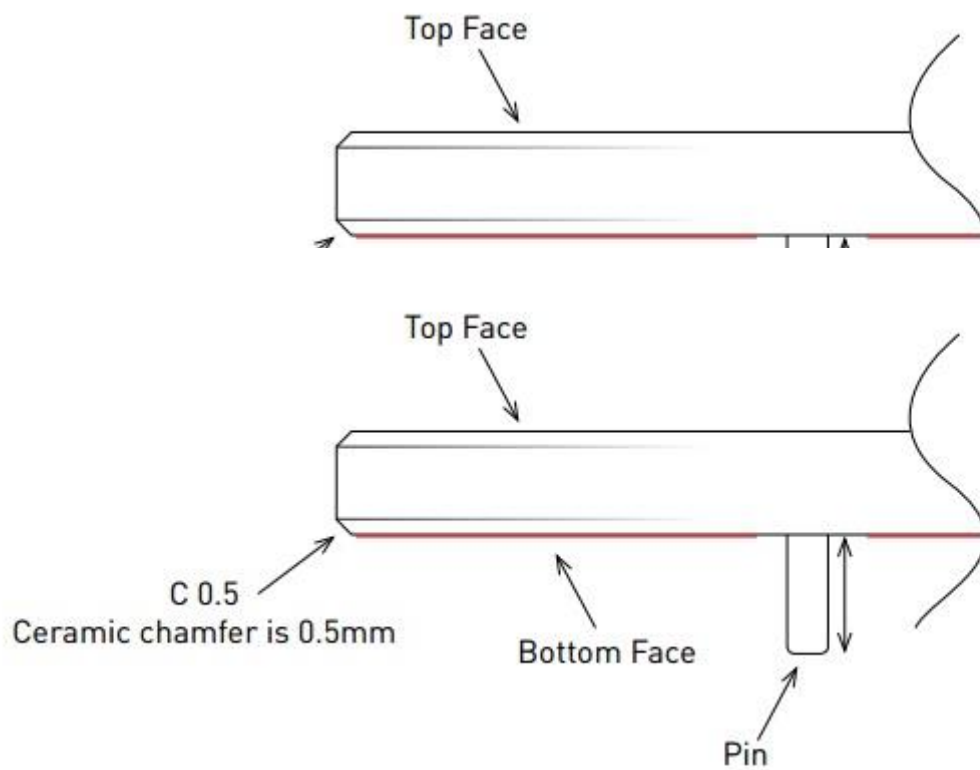

**Red Line** shows the adhesive without Liner – thickness 0.08-0.1mm

## 7. PCB Footprint Recommendation

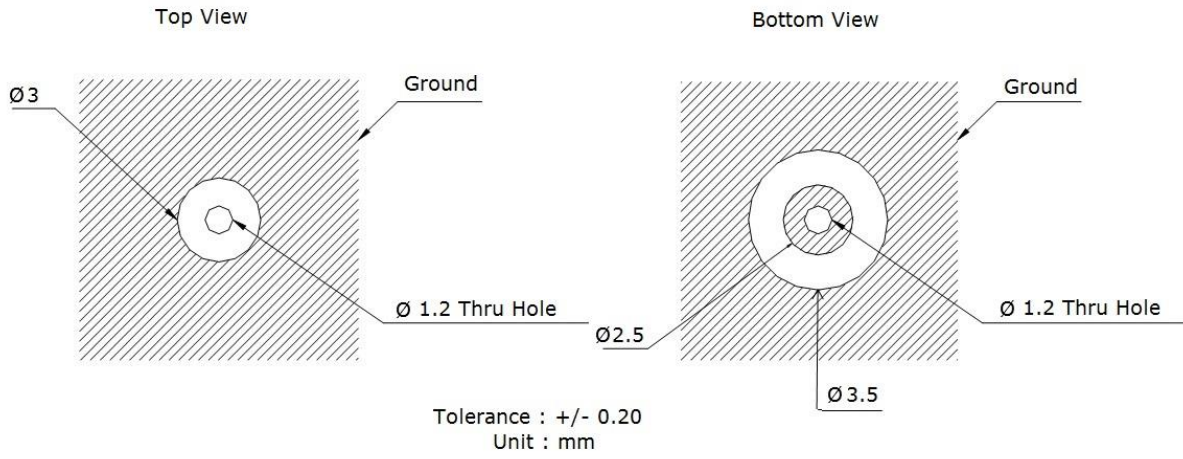

## 8. Antenna Integration Guide

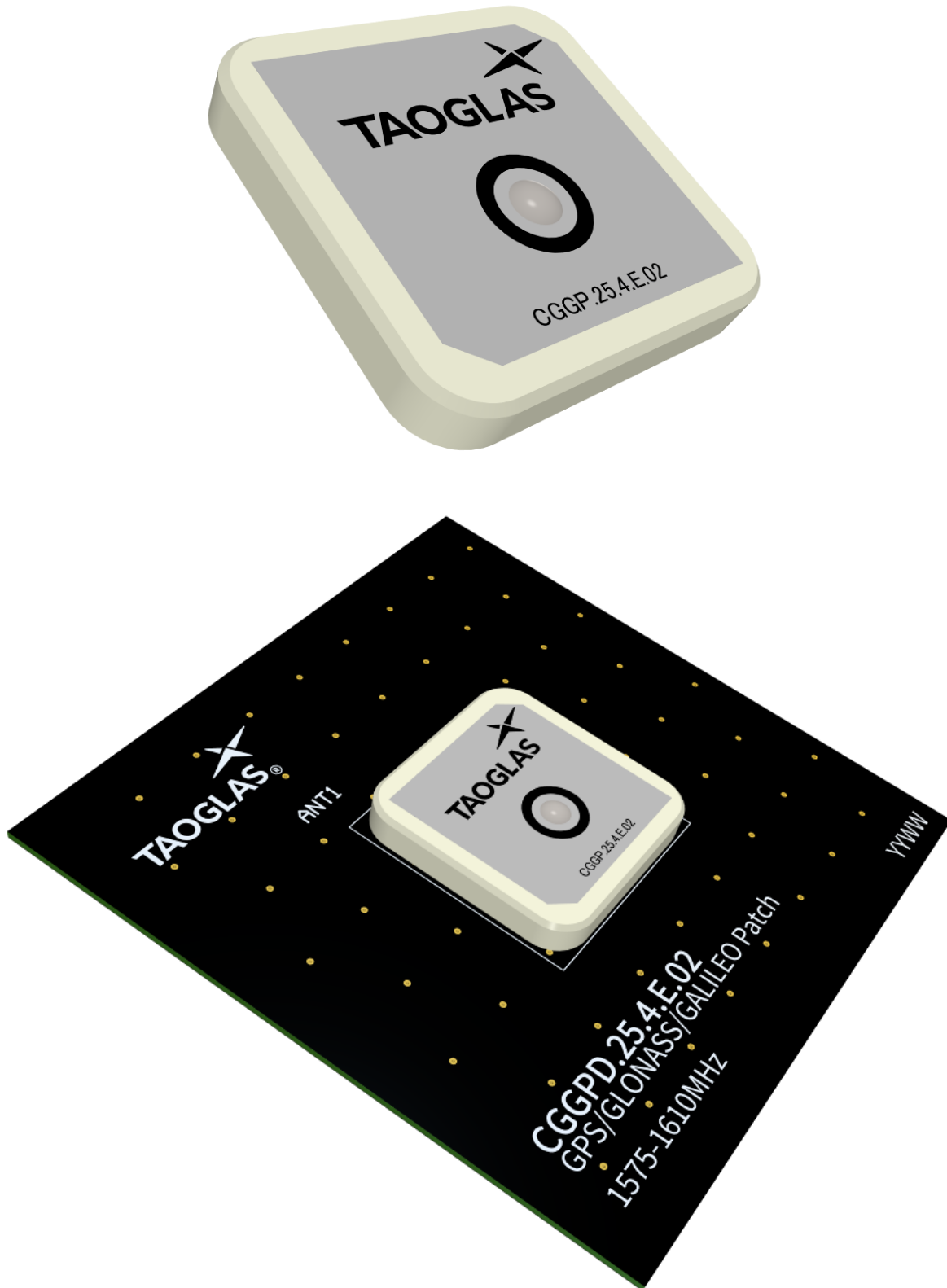

## 8.1 Schematic Symbol and Pin Definition

The circuit symbol for the antenna is shown below. The antenna has 1 pin as indicated below.

Pin	Description
1	RF Feed

TAOGLAS\_CG GP.182.A.02  
ANTI

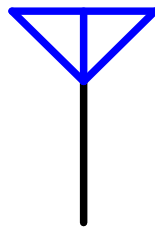

## 8.2 Antenna Integration

The antenna should be placed at the center of the ground plane with a length and width of 70mm. Maintaining a square symmetric ground plane shape and symmetric environment around the antenna is critical to maintaining the excellent axial ratio and phase center performance shown in this datasheet.



Top Side w/ Solder Mask



Top Side w/o Solder Mask



### 8.3 PCB Layout

The footprint and clearance on the PCB must comply with the antenna specification. The PCB layout shown in the diagram below demonstrates the antenna footprint.

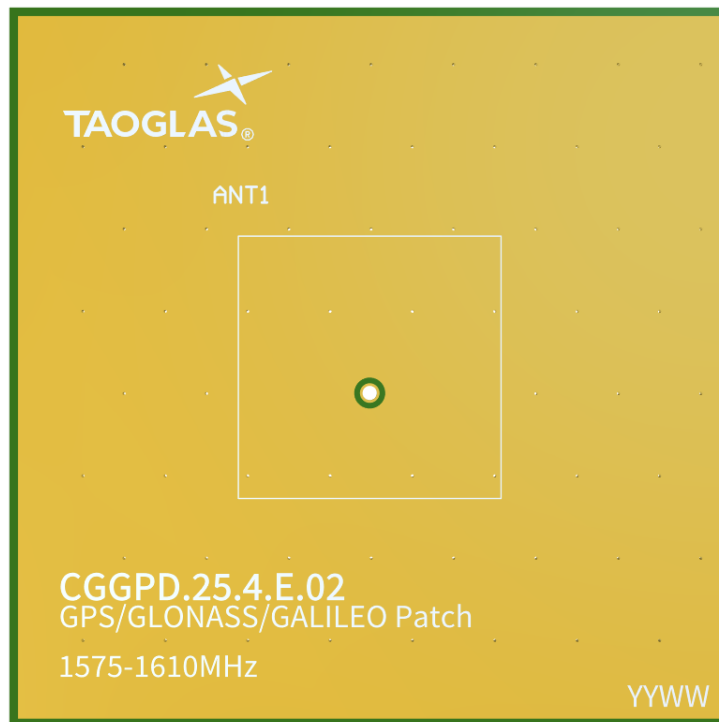

Topside

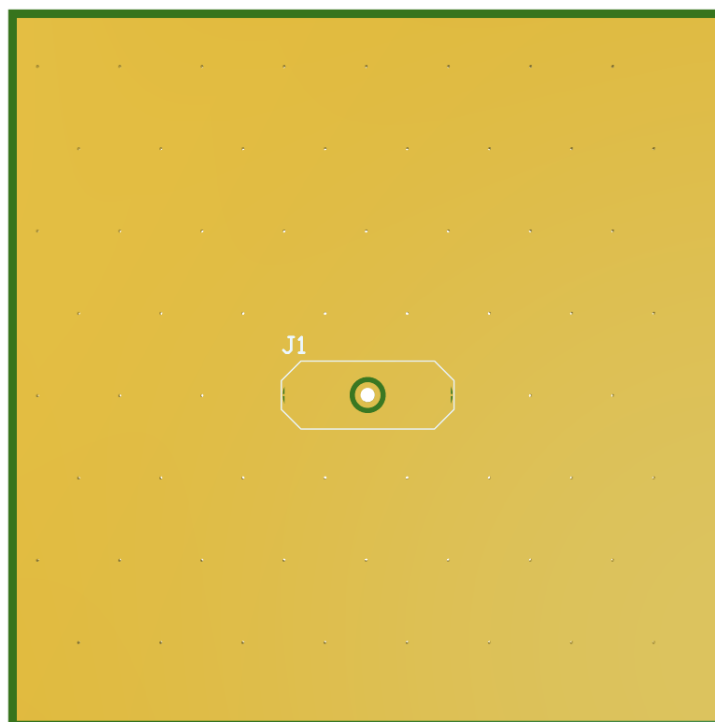

Bottom Side

8.5 Evaluation Board



Topside

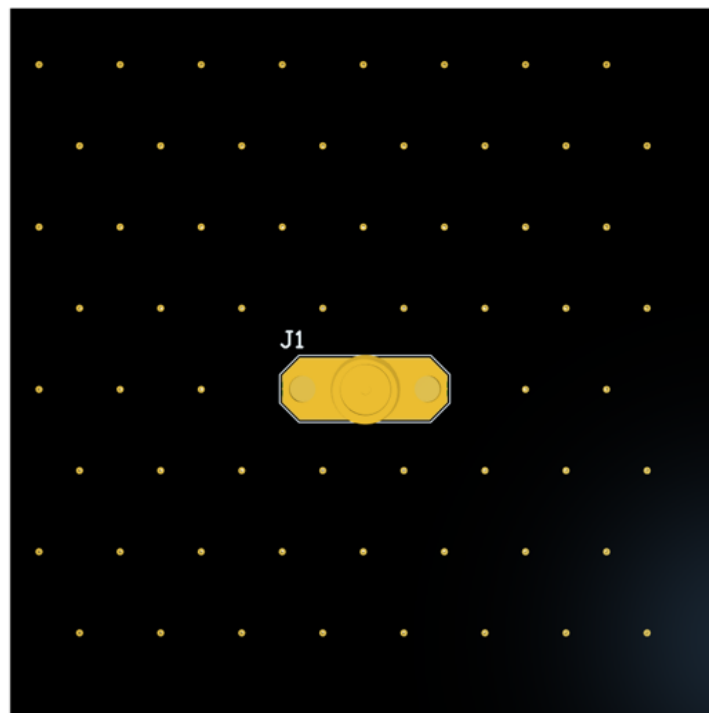

Bottom Side

# 9. Evaluation Board Mechanical Drawing

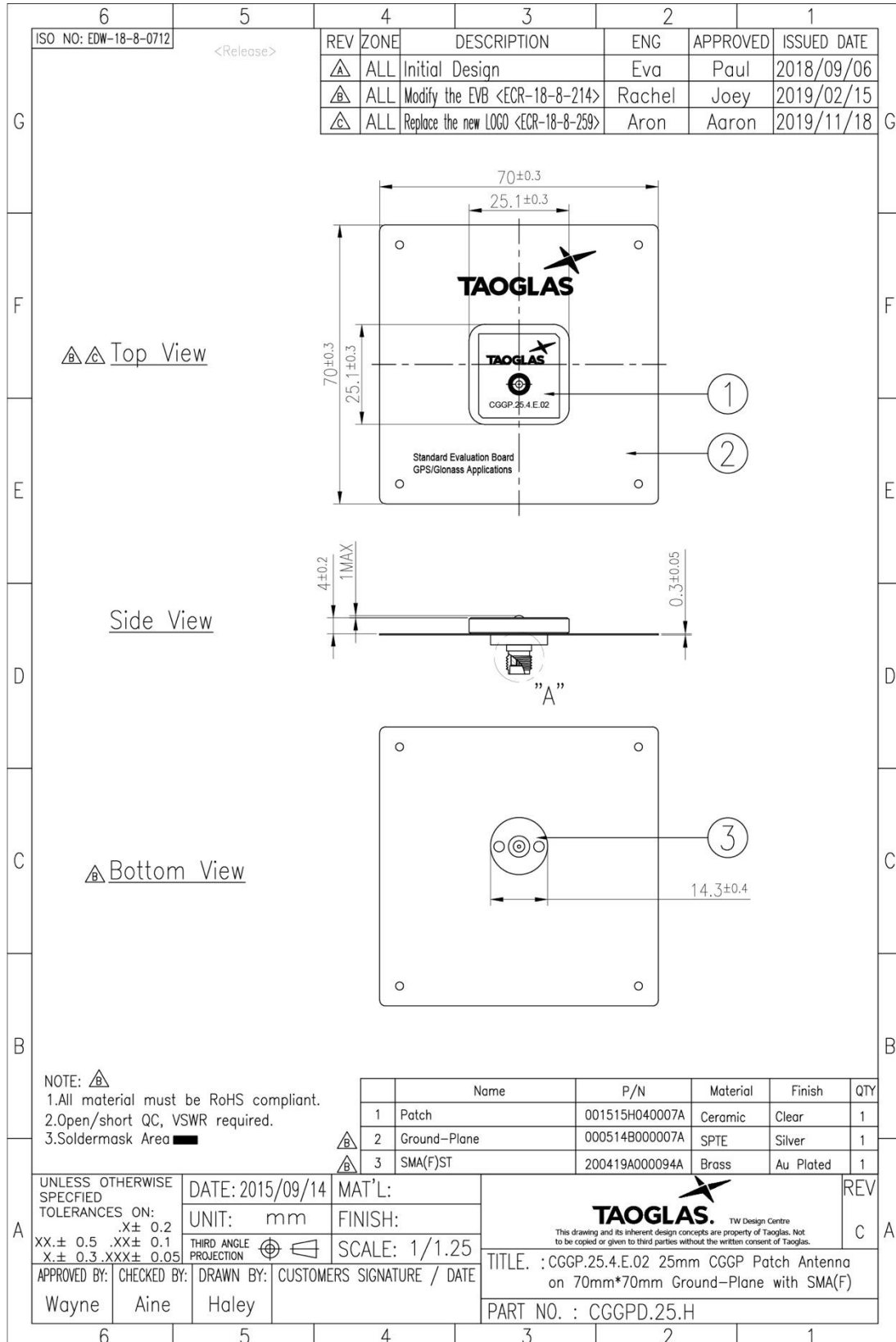

## 10. Packaging

### CGGP.25.4.E.02

#### Packaging Specifications

50 pcs CGGP.25.4.E.02 per tray  
 Tray Dimensions - 255\*145\*32mm  
 Weight - 519g

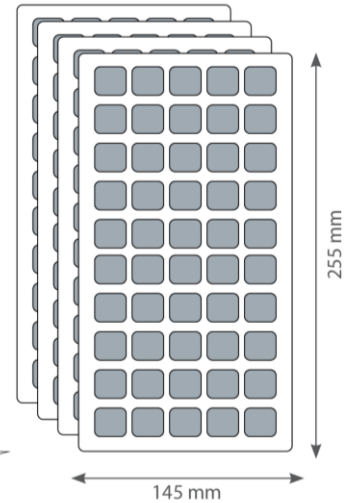

200 pcs CGGP.25.4.E.02 per Inner Carton  
 Inner Carton Dimensions - 261\*152\*118mm  
 Weight - 2.2kg

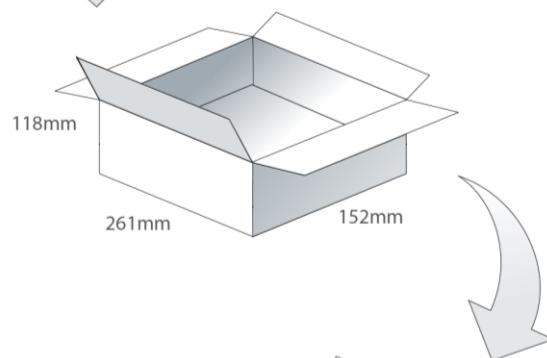

800 pcs CGGP.25.4.E.02 per Carton  
 Carton Dimensions - 370\*370\*300mm  
 Weight - 9.3kg

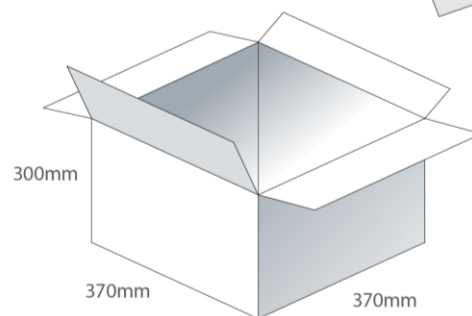

Changelog for the datasheet

**SPE-16-8-018 – CGGP.25.E.02**

**Revision: F (Current Version)**

Date:	2023-02-27
Changes:	Integration Guide Added
Changes Made by:	Cesar Sousa

**Previous Revisions**

**Revision: E**

Date:	2022-02-17
Changes:	Updated Packaging Graphic
Changes Made by:	Paul Doyle

**Revision: D**

Date:	2021-06-12
Changes:	Updated Pin Length to 2.4mm Updated Drawing
Changes Made by:	Dan Cantwell

**Revision: C**

Date:	2020-11-19
Changes:	Updated to new format Added Moisture Sensitivity Level 3 to Environmental Specifications
Changes Made by:	Dan Cantwell

**Revision: B**

Date:	2019-11-15
Changes:	Updated Images Reference ECR-18-8-259
Changes Made by:	Russell Meyler

**Revision: A (Original First Release)**

Date:	2016-09-03
Notes:	
Author:	Jack Conroy



**TAOGLAS**®

[www.taoglas.com](http://www.taoglas.com)



# Mouser Electronics

Authorized Distributor

Click to View Pricing, Inventory, Delivery & Lifecycle Information:

[Taoglas:](#)

[CGGP.25.4.E.02](#) [CGGPD.25.H](#)