

40W isolated DC-DC converter in 1x1 inch
Ultra-wide input and regulated single output

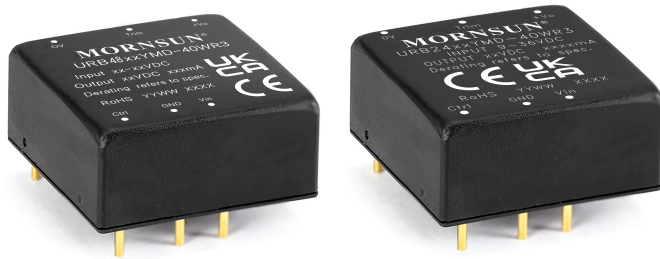

Patent Protection
CE Report EN62368-1
UKCA Report BS EN62368-1
RoHS

FEATURES

- Ultra-Wide 4:1 input voltage range
- High efficiency up to 91.5%
- No-load power consumption as low as 0.096W
- I/O isolation test voltage 1.5k VDC
- Input under-voltage protection, output short-circuit, over-current, over-voltage, over-temperature protection
- Operating ambient temperature range: -40°C to +105°C
- Industry standard pin-out
- Meets EN62368 standards

URB_YMD-40WR3 series of isolated 40W DC-DC converter products with an ultra-wide 4:1 input voltage range. They feature efficiencies up to 91.5%, input to output isolation is tested with 1500VDC and the converter safely operate ambient temperature of -40°C to +105°C, input under-voltage protection, output short-circuit, over-current, over-voltage and over-temperature protection. They are ideally and widely used in applications such as industrial control, electric power, instruments and communications.

Selection Guide

Certification	Part No.	Input Voltage (VDC)		Output		Full Load Efficiency [®] (%) Min./Typ.	Capacitive Load (μF)Max.
		Nominal (Range)	Max. ^②	Voltage (VDC)	Current(mA) Max./Min.		
EN/BS EN	URB2403YMD-40WR3	24 (9-36)	40	3.3	10000/0	87/89.5	7200
	URB2405YMD-40WR3			5	8000/0	88/90	7200
	URB2412YMD-40WR3 ^①			12	3333/0	89/91.2	2000
	URB2415YMD-40WR3			15	2667/0	89/91.5	1500
	URB2424YMD-40WR3			24	1667/0	88/90.1	1000
	URB2428YMD-40WR3			28	1429/0	88/90.1	1000
	URB4803YMD-40WR3	48 (18-75)	75	3.3	10000/0	87/89	7200
	URB4805YMD-40WR3			5	8000/0	88/90	7200
	URB4812YMD-40WR3			12	3333/0	89/91	2000
	URB4815YMD-40WR3			15	2667/0	89/91	1500

Notes:
 ① When the URB2412YMD-40WR3 suffix adds "H" for the package with heat sink, such as applied to the occasion with higher requirements for heat dissipation, you can choose our company with heat sink module;
 ② Exceeding the maximum input voltage may cause permanent damage;
 ③ Efficiency is measured in nominal input voltage and rated output load;
 ④ Rated output load is derated to 75% at minimum input voltage.

Input Specifications

Item	Operating Conditions	Min.	Typ.	Max.	Unit
Input Current (full load / no-load)	24VDC nominal input series, nominal input voltage	3.3V output	1545/4	1580/12	mA
		Others	1852/4	1894/12	
	48VDC nominal input series, nominal input voltage	3.3V output	772/7	790/15	
		Others	926/7	947/15	
Reflected Ripple Current	nominal input series	--	100	--	
Surge Voltage (1sec. max.)	24VDC nominal input series	-0.7	--	50	VDC
	48VDC nominal input series	-0.7	--	100	
Start-up Voltage	24VDC nominal input series	--	--	9	
	48VDC nominal input series	--	--	18	
Input under-voltage protection	24VDC nominal input series	5.5	7.5	--	

	48VDC nominal input series	12	15	--	
Start-up Time	Nominal input voltage & constant resistance load	--	30	100	ms
Input Filter		Capacitance filter			
Hot Plug		Unavailable			
Ctrl*	Module on	Ctrl pin open or pulled high (TTL 3.5-12VDC)			
	Module off	Ctrl pin pulled low to GND (0-1.2VDC)			
	Input current when off	--	6	12	mA

Note: *The Ctrl pin voltage is referenced to input GND.

Output Specifications

Item	Operating Conditions	Min.	Typ.	Max.	Unit
Voltage Accuracy ^①	5%-100% load	--	±1	±3	%
Linear Regulation	Input voltage variation from low to high at full load	--	±0.2	±0.5	
Load Regulation ^②	5%-100% load	--	±0.5	±1	
Transient Recovery Time	25% load step change, nominal input voltage	--	250	500	μs
Transient Response Deviation	25% load step change, input voltage range	--	±5	±8	%
Temperature Coefficient	Full load	--	--	±0.03	%/°C
Ripple & Noise ^③	20MHz bandwidth, nominal input voltage, 5%-100% load	--	100	150	mV p-p
Trim	Input voltage range	90	--	110	%Vo
Over-temperature Protection	Max. Case Temperature	--	125	--	°C
Over-voltage Protection	Input voltage range	110	140	160	%Vo
Over-current Protection		110	140	200	%Io
Short circuit Protection		Hiccup, continuous, self-recovery			

Note:
 ① Output voltage accuracy for 0%-5% load is ±5% max;
 ② Load regulation for 0% -100% load increases to ±3%;
 ③ Under 0% -5% load conditions, ripple & noise does not exceed 5%Vo. By measuring method is used for Ripple and Noise test, please refer to Fig. 2. for recommended circuit.

General Specifications

Item	Operating Conditions	Min.	Typ.	Max.	Unit
Isolation	Input-output Electric Strength Test for 1 minute with a leakage current of 1mA max.	1500	--	--	VDC
Insulation Resistance	Input-output resistance at 500VDC	1000	--	--	MΩ
Isolation Capacitance	Input-output capacitance at 100kHz/0.1V	24VDC input series	--	10	nF
		48VDC input series	--	2.2	
Operating Temperature	See Fig. 1	-40	--	+105	°C
Max. Case Temperature	Rated output load	--	110	--	
Storage Temperature		-55	--	+125	
Storage Humidity	Non-condensing	5	--	95	%RH
Pin Soldering Resistance Temperature	Soldering spot is 1.5mm away from case for 10 seconds	--	--	+300	°C
Vibration		10-150Hz, 5G, 0.75mm. along X, Y and Z			
Switching Frequency *	PWM mode	--	400	--	kHz
MTBF	MIL-HDBK-217F@25°C	1000	--	--	k hours

Note: *Switching frequency is measured at full load. The module reduces the switching frequency for light load (below 50%) efficiency improvement.

Mechanical Specifications

Case Material	Aluminum alloy				
Dimensions	URB24_YMD-40WR3	25.40 x 25.40 x 11.70 mm			
	URB24_YMD-40W(H)R3	25.40 x 25.40 x 16.20 mm			

Weight	URB24_YMD-40WR3	20.0g(Typ.)
	URB24_YMD-40W(H)R3	23.4g(Typ.)
Cooling method	Free air convection	

Electromagnetic Compatibility (EMC)

Emissions	CE	CISPR32/EN55032	CLASS B (see Fig.3-② for recommended circuit)	
	RE	CISPR32/EN55032	CLASS B (see Fig.3-② for recommended circuit)	
Immunity	ESD	IEC/EN61000-4-2	Contact ±6kV	perf. Criteria B
	RS	IEC/EN61000-4-3	10V/m	perf. Criteria A
	EFT	IEC/EN61000-4-4	±2kV (see Fig.3-① for recommended circuit)	perf. Criteria A
	Surge	IEC/EN61000-4-5	line to line ±2kV (see Fig.3-① for recommended circuit)	perf. Criteria A
	CS	IEC/EN61000-4-6	3 Vr.m.s	perf. Criteria A

Typical Characteristic Curves

URB2403YMD-40WR3
Temperature Derating Curve

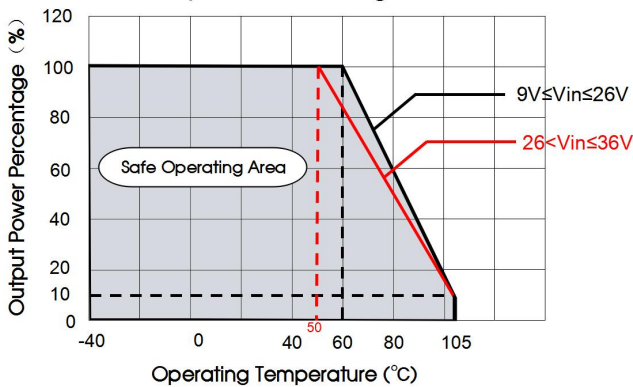

URB2405YMD-40WR3
Temperature Derating Curve

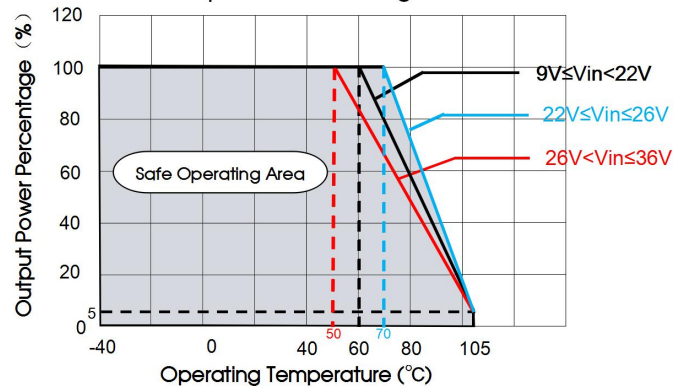

URB2412/15YMD-40WR3
Temperature Derating Curve

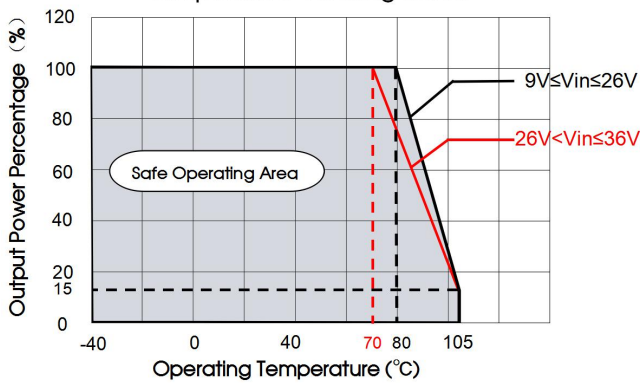

URB2424/28YMD-40WR3
Temperature Derating Curve

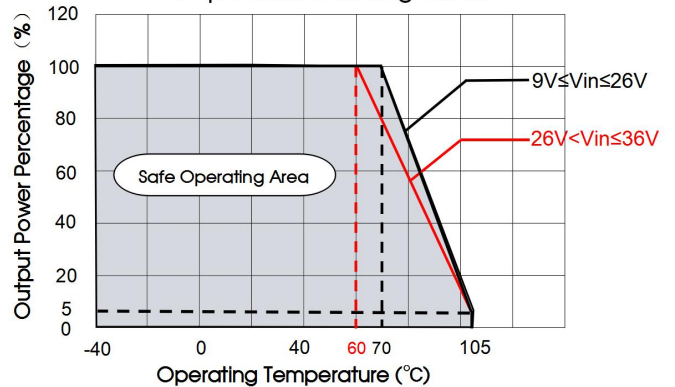

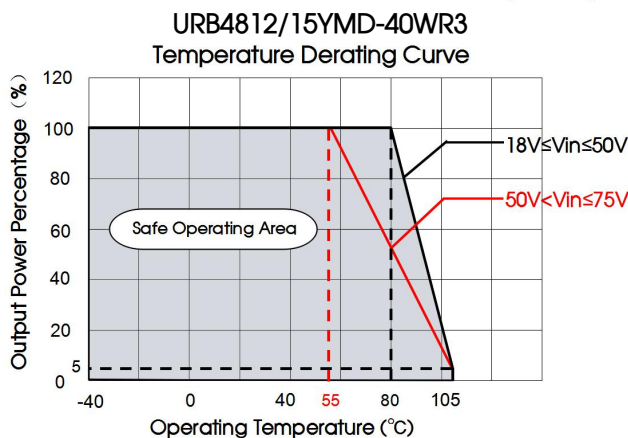
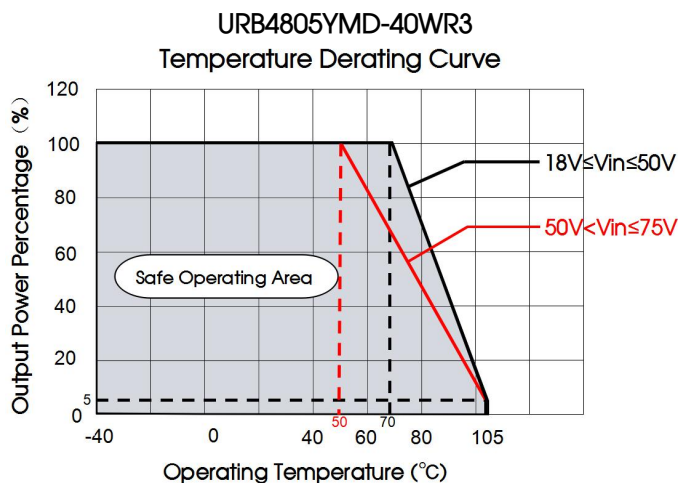
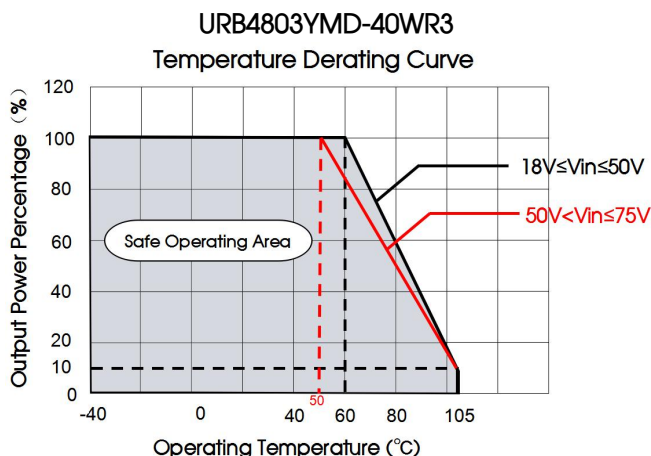
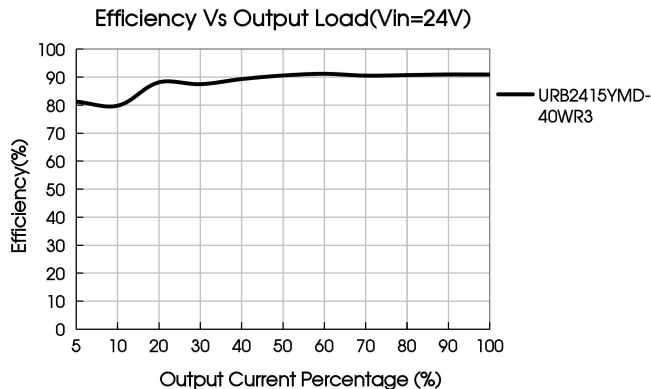
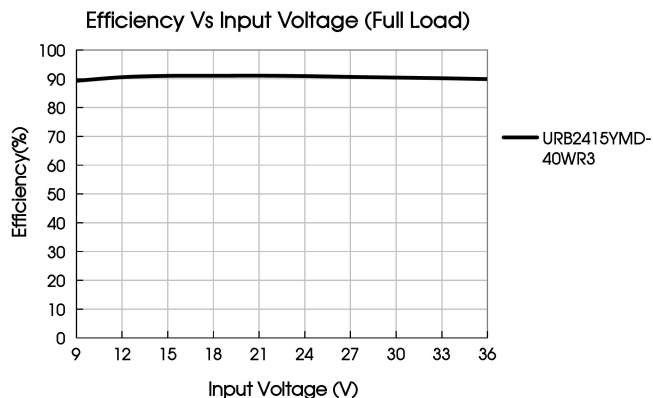
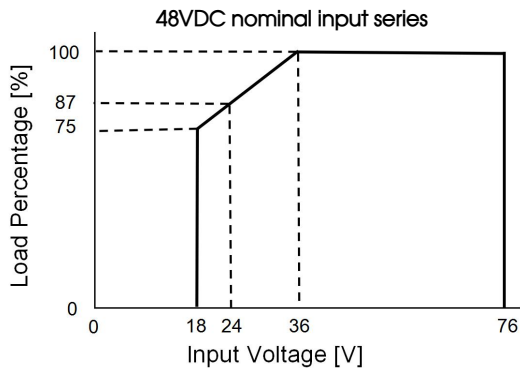
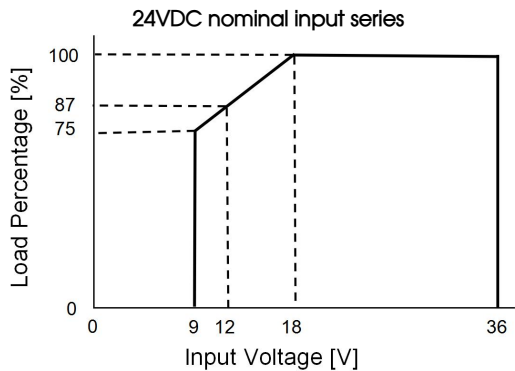
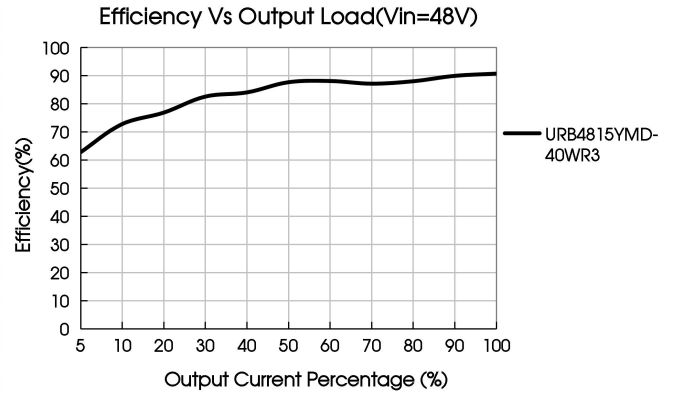
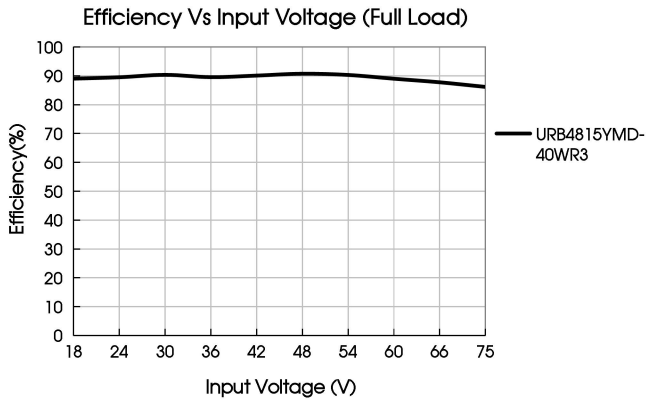

Fig. 1





Design Reference

1. Typical application

All DC-DC converters of this series are tested before delivery using the recommended circuit shown in Fig. 2.

Input and/or output ripple can be further reduced by appropriately increasing the input & output capacitor values C_{in} and C_{out} and/or by selecting capacitors with a low ESR (equivalent series resistance). Also make sure that the capacitance is not exceeding the specified max. capacitive load value of the product.

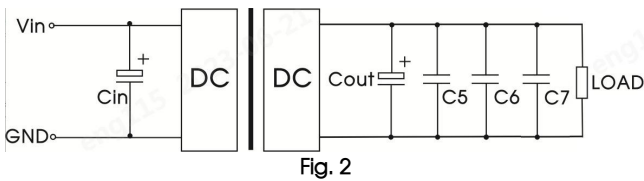

Vin (VDC)	Vout (VDC)	Cin	Cout	C5	C6	C7
24	3.3-5	100uF/50V	470uF/50V	22uF/16V	1uF/16V	10uF/16V
	12/15			22uF/25V	1uF/25V	10uF/25V
	24/28			22uF/50V	1uF/50V	10uF/50V
48	3.3/5	100uF/100V	470uF/50V	22uF/16V	1uF/16V	10uF/16V
	12/15			22uF/25V	1uF/25V	10uF/25V

2. EMC compliance circuit

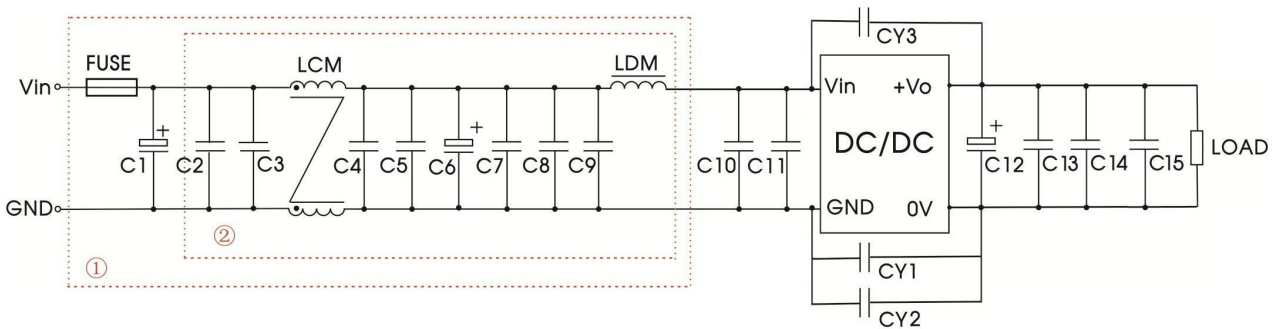

Fig. 3

Notes: We use Part ① in Fig. 3 for Immunity tests and Part ② for Emissions test. Selecting based on needs.

Parameter description:

Components	Vin: 24VDC	Vin: 48VDC
FUSE	Choose according to actual input current	
C1	1000uF/50V	680uF/100V
C2/C3/C4/C5/ C7/C8/C9	4.7uF/50V	4.7uF/100V
LCM	350uH*2, Recommend use Mornsun P/N, FL2D-30-351	10mH*2, Recommend use Ceciya FL1515-007
C6	220uF/50V	100uF/100V
LDM	2.2uH	6.8uH
C12	Refer to the Cout in Fig.2	
C13/C14	Refer to the C5, C6 in Fig.2	
C15	/	Refer to the C7 in Fig.2
C10/C11	/	4.7uF/100V
CY1	Y2/222K/250VAC	2200PF/3000VDC
CY2/CY3	/	2200PF/3000VDC

Note: The Part ② of the circuit can be simplified, and ClassA can be satisfied by removing the LCM.

3. Trim Function for Output Voltage Adjustment (open if unused)

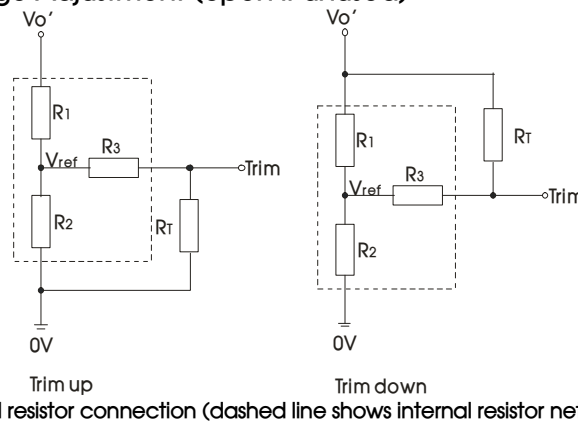

Calculating Trim resistor values:

$$\begin{aligned} \text{up: } R_T &= \frac{aR_2}{R_2 - a} - R_3 & a &= \frac{V_{ref}}{V_{o'} - V_{ref}} \cdot R_1 \\ \text{down: } R_T &= \frac{aR_1}{R_1 - a} - R_3 & a &= \frac{V_{o'} - V_{ref}}{V_{ref}} \cdot R_2 \end{aligned}$$

R_T is Trim resistance
 a is a self-defined parameter,
with no real meaning.

Vout(V)	R1(kΩ)	R2(kΩ)	R3(kΩ)	Vref(V)
3.3	4.83	2.87	4.7	1.25
5	2.87	2.87	5.6	2.5
12	10.91	2.87	15	2.5
15	14.35	2.87	15	2.5
24	24.77	2.87	17.4	2.5
28	29.41	2.87	17.4	2.5

4. The products do not support parallel connection of their output

5. For additional information please refer to DC-DC converter application notes on www.mornsun-power.com

URB_YMD-40WR3 Series Dimensions and Recommended Layout

THIRD ANGLE PROJECTION 

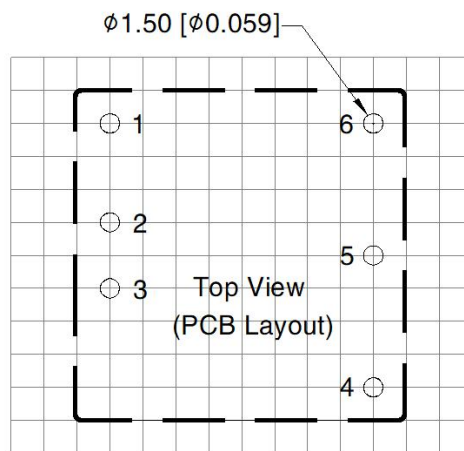
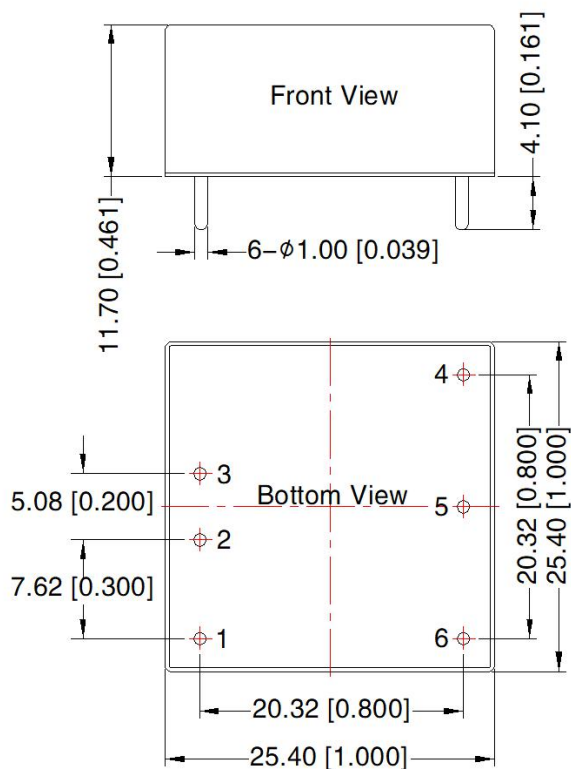

Note: Grid 2.54*2.54mm

Note:
Unit: mm[inch]
Pin diameter tolerances: $\pm 0.10[\pm 0.004]$
General tolerances: $\pm 0.80[\pm 0.031]$

Pin-Out	
Pin	Mark
1	Ctrl
2	GND
3	Vin
4	+Vo
5	Trim
6	0V

URB_YMD-40WHR3 Series Dimensions and Recommended Layout

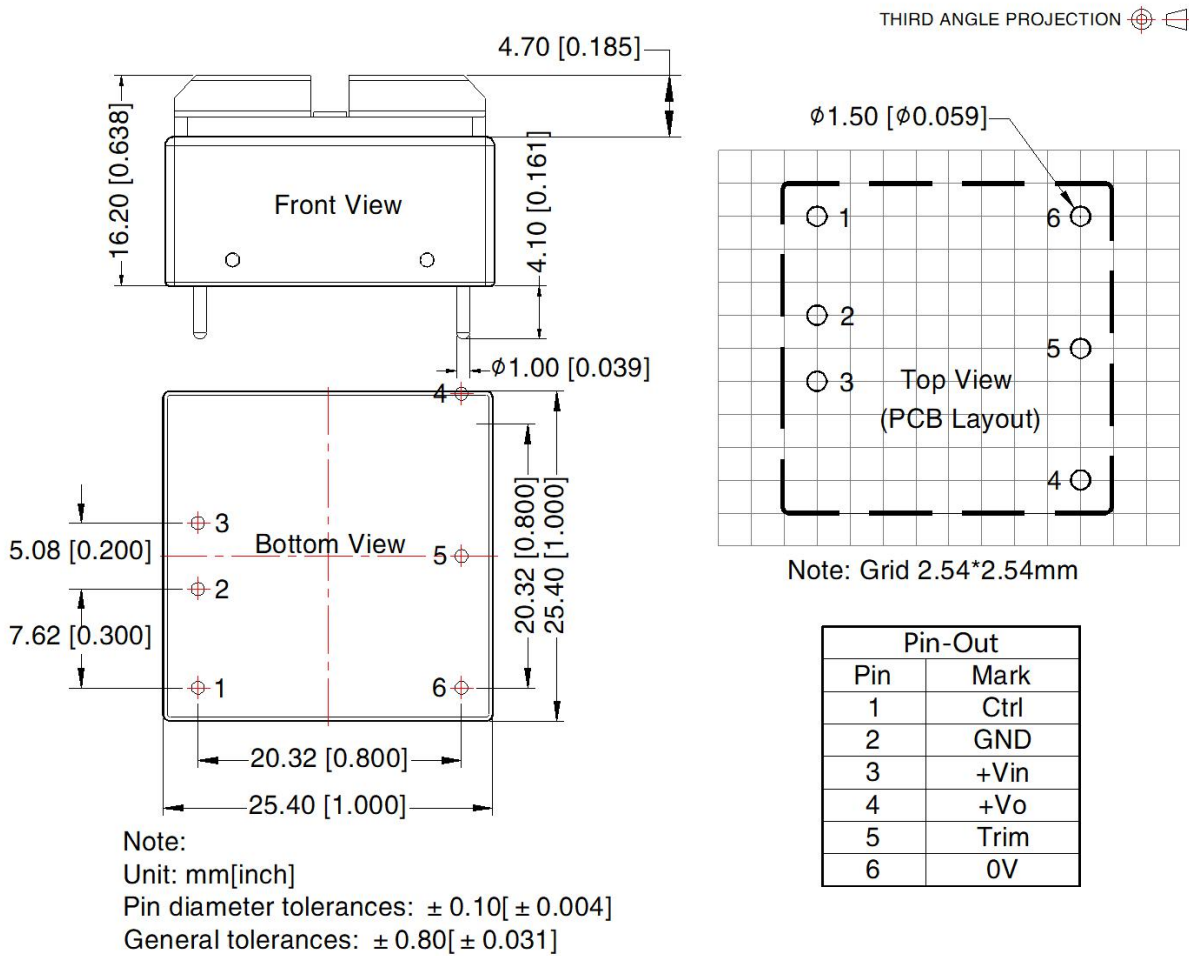

- Note:
- For additional information on Product Packaging please refer to www.mornsun-power.com. Packaging bag number: 58200048;
 - The maximum capacitive load offered were tested at input voltage range and full load;
 - Unless otherwise specified, parameters in this datasheet were measured under the conditions of $T_a=25^{\circ}\text{C}$, humidity<75%RH with nominal input voltage and rated output load;
 - All index testing methods in this datasheet are based on company corporate standards;
 - We can provide product customization service, please contact our technicians directly for specific information;
 - Products are related to laws and regulations: see "Features" and "EMC";
 - Our products shall be classified according to ISO14001 and related environmental laws and regulations, and shall be handled by qualified units.

Mornsun Guangzhou Science & Technology Co., Ltd.

Address: No. 5, Kehui St. 1, Kehui Development Center, Science Ave., Guangzhou Science City, Huangpu District, Guangzhou, P. R. China
Tel: 86-20-38601850 Fax: 86-20-38601272 E-mail: info@mornsun.cn www.mornsun-power.com