

LIN J2602 Transceiver

Features

- The MCP2003 and MCP2004 are compliant with LIN Bus Specifications 1.3, 2.0 and 2.1 and are compliant to SAE J2602
- Support Baud Rates up to 20 Kbaud with LIN-compatible output driver
- 43V load dump protected
- Very low EMI meets stringent OEM requirements
- Very high ESD immunity:
 - >20kV on VBB (IEC 61000-4-2)
 - >14kV on LBUS (IEC 61000-4-2)
- Very high immunity to RF disturbances meets stringent OEM requirements
- Wide supply voltage, 6.0V-27.0V continuous
- Extended Temperature Range: -40 to +125°C
- Interface to PIC[®] MCU EUSART and standard USARTs
- Local Interconnect Network (LIN) bus pin:
 - Internal pull-up resistor and diode
 - Protected against battery shorts
 - Protected against loss of ground
 - High current drive
- Automatic thermal shutdown
- Low-power mode:
 - Receiver monitoring bus and transmitter off, ($\cong 5 \mu\text{A}$)



Description

This device provides a bidirectional, half-duplex communication physical interface to automotive and industrial LIN systems to meet the LIN bus specification Revision 2.1 and SAE J2602. The device is short circuit and overtemperature protected by internal circuitry. The device has been specifically designed to operate in the automotive operating environment and will survive all specified transient conditions while meeting all of the stringent quiescent current requirements.

MCP200X family members:

- 8-pin PDIP, DFN and SOIC packages:
 - MCP2003, LIN-compatible driver, with WAKE pins
 - MCP2004, LIN-compatible driver, with FAULT/TXE pins

Package Types

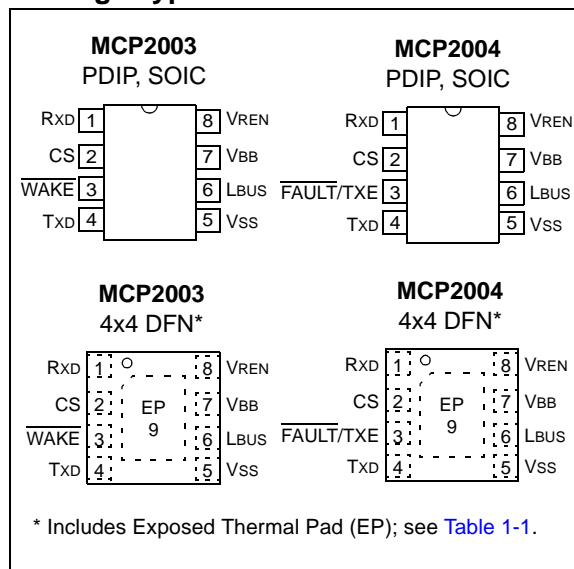

MCP2003/4

MCP2003 Block Diagram

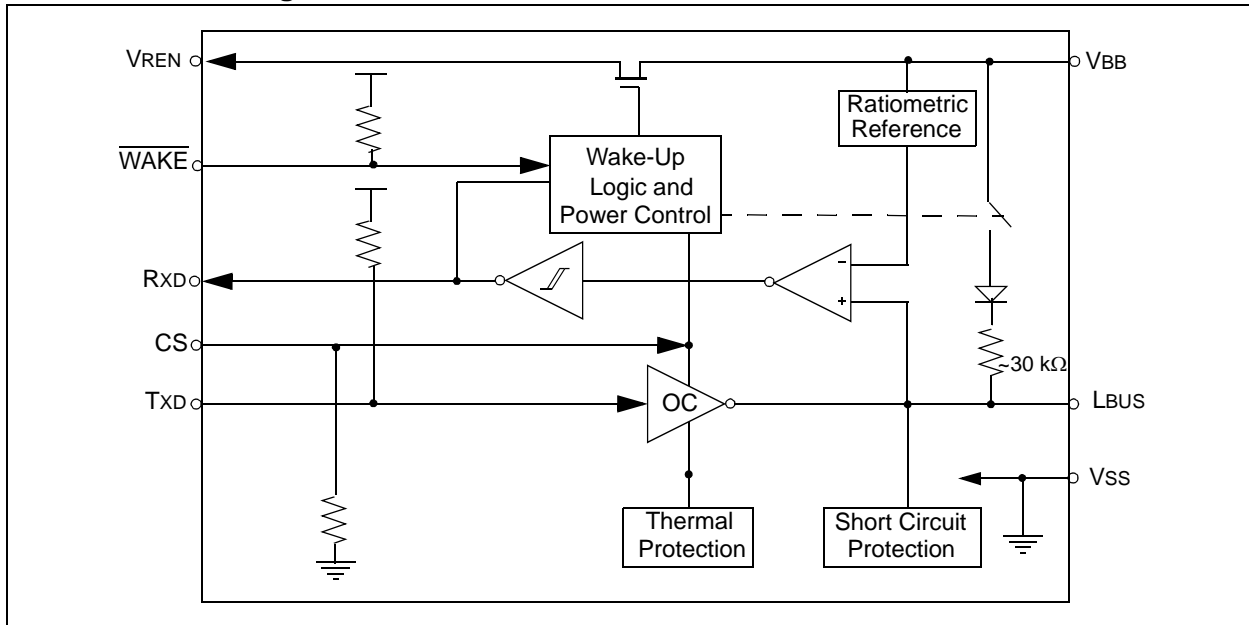

MCP2004 Block Diagram

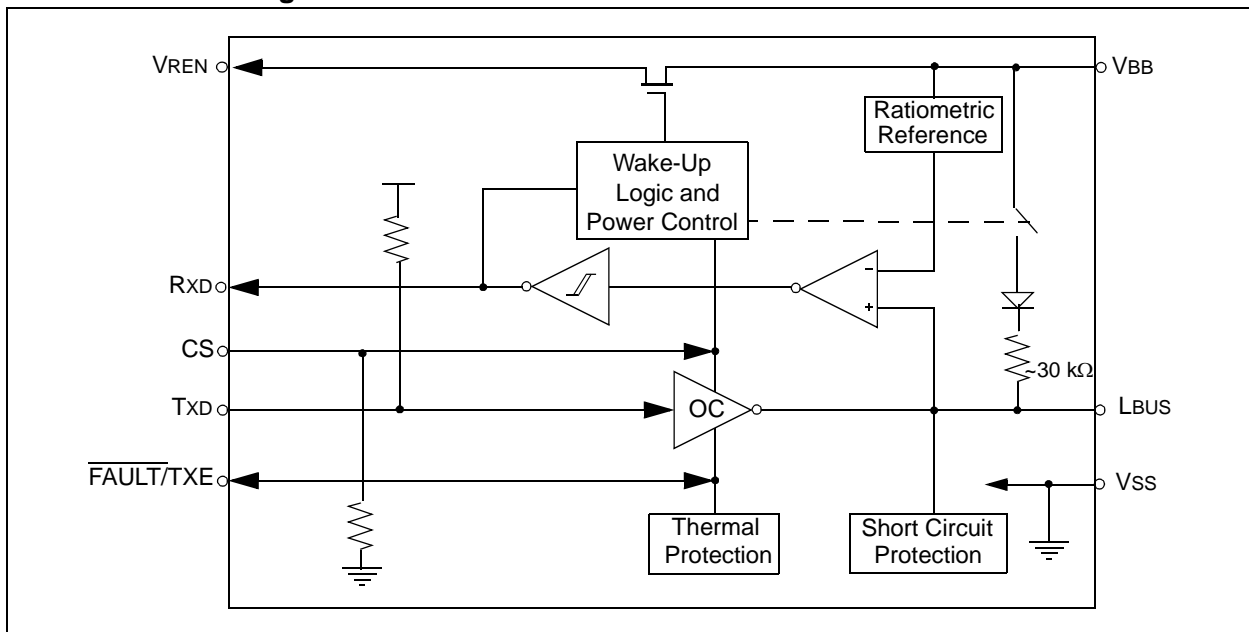

1.0 DEVICE OVERVIEW

The MCP2003/4 provides a physical interface between a microcontroller and a LIN bus. This device will translate the CMOS/TTL logic levels to LIN logic level, and vice versa. It is intended for automotive and industrial applications with serial bus speeds up to 20 Kbaud.

LIN specification 2.1 requires that the transceiver of all nodes in the system is connected via the LIN pin, referenced to ground and with a maximum external termination resistance of 510Ω from LIN bus to battery supply. The 510Ω corresponds to 1 master and 15 slave nodes.

The VREN pin can be used to drive the logic input of an external voltage regulator. This pin is high in all modes except for Power Down mode.

1.1 External Protection

1.1.1 REVERSE BATTERY PROTECTION

An external reverse-battery-blocking diode should be used to provide polarity protection (see [Example 1-1](#)).

1.1.2 TRANSIENT VOLTAGE PROTECTION (LOAD DUMP)

An external 43V transient suppressor (TVS) diode, between VBB and ground, with a 50Ω transient protection resistor (RTP) in series with the battery supply and the VBB pin serve to protect the device from power transients (see [Example 1-1](#)) and ESD events. While this protection is optional, it is considered good engineering practice.

1.2 Internal Protection

1.2.1 ESD PROTECTION

For component-level ESD ratings, please refer to the maximum operation specifications.

1.2.2 GROUND LOSS PROTECTION

The LIN Bus specification states that the LIN pin must transition to the recessive state when ground is disconnected. Therefore, a loss of ground effectively forces the LIN line to a high-impedance level.

1.2.3 THERMAL PROTECTION

The thermal protection circuit monitors the die temperature and is able to shut down the LIN transmitter.

There are two causes for a thermal overload. A thermal shut down can be triggered by either, or both, of the following thermal overload conditions.

- LIN bus output overload
- Increase in die temperature due to increase in environment temperature

Driving the TXD and checking the RXD pin makes it possible to determine whether there is a bus contention (Rx = low, Tx = high) or a thermal overload condition (Rx = high, Tx = low). After a thermal overload event, the device will automatically recover once the die temperature has fallen below the recovery temperature threshold. See [Figure 1-1](#).

FIGURE 1-1: THERMAL SHUTDOWN STATE DIAGRAM

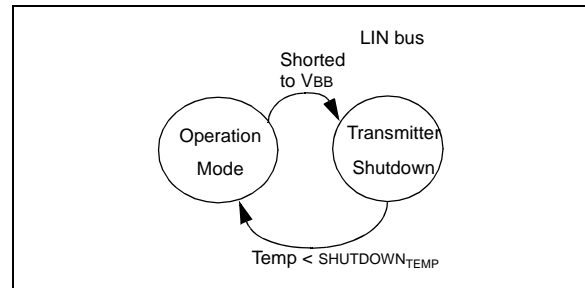

MCP2003/4

1.3 Modes of Operation

For an overview of all operational modes, refer to [Table 1-1](#).

1.3.1 POWER-DOWN MODE

In Power Down mode, the transmitter and VREN are both off. Only the receiver section and the wake-up circuits are operational. This is the lowest power mode.

On bus activity (e.g. a BREAK character), CS going to a high level, or on a falling edge on WAKE, the device will immediately enter Ready mode. If CS is held high as the device transitions from Power Down to Ready mode, the device will transition to Operation mode as soon as internal voltages stabilize.

Note: Bus activity is defined as L_{BUS} dropping below V_{IL}(L_{BUS}) for longer than the Bus Activity Debounce time (t_{BDB}).

1.3.2 READY MODE

Upon entering the Ready mode, VREN is enabled and the receiver detect circuit is powered up. The transmitter remains disabled and the device is ready to receive data but not to transmit.

Upon VBB supply pin power-on, the device will remain in Ready mode as long as CS is low. If CS transitions high, the device will enter Operation mode. However, if

the TXD pin is held low when CS goes high, the device will transition to Transmitter Off mode instead of Operation mode.

1.3.3 OPERATION MODE

In this mode, all internal modules are operational.

The MCP2003/4 will go into the Power Down mode on the falling edge of CS. The MCP2003/4 will enter Transmitter Off mode in the event of a Fault condition. These include: thermal overload, bus contention and TXD timer expiration.

The MCP2004 device can also enter Transmitter Off mode if the FAULT/TXE pin is pulled low

1.3.4 TRANSMITTER OFF MODE

Transmitter Off mode is reached whenever the transmitter is disabled either due to a Fault condition or pulling the nFAULT/TXE pin low on the MCP2004. The fault conditions include: thermal overload, bus contention or TXD timer expiration.

The MCP2003/4 will go into Power Down mode on falling edge of CS, or return to Operation mode if all faults are resolved and the FAULT/TXE pin on the MCP2004 is high.

FIGURE 1-2: OPERATIONAL MODES STATE DIAGRAM – MCP2003

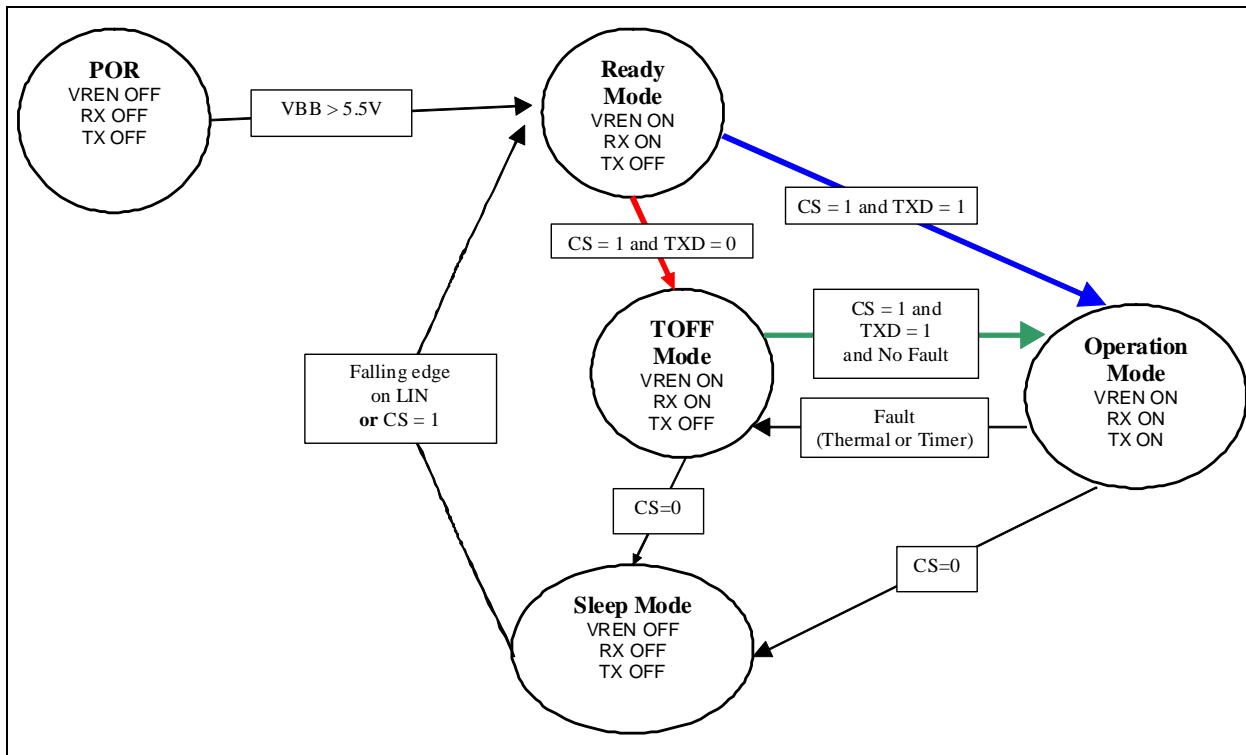
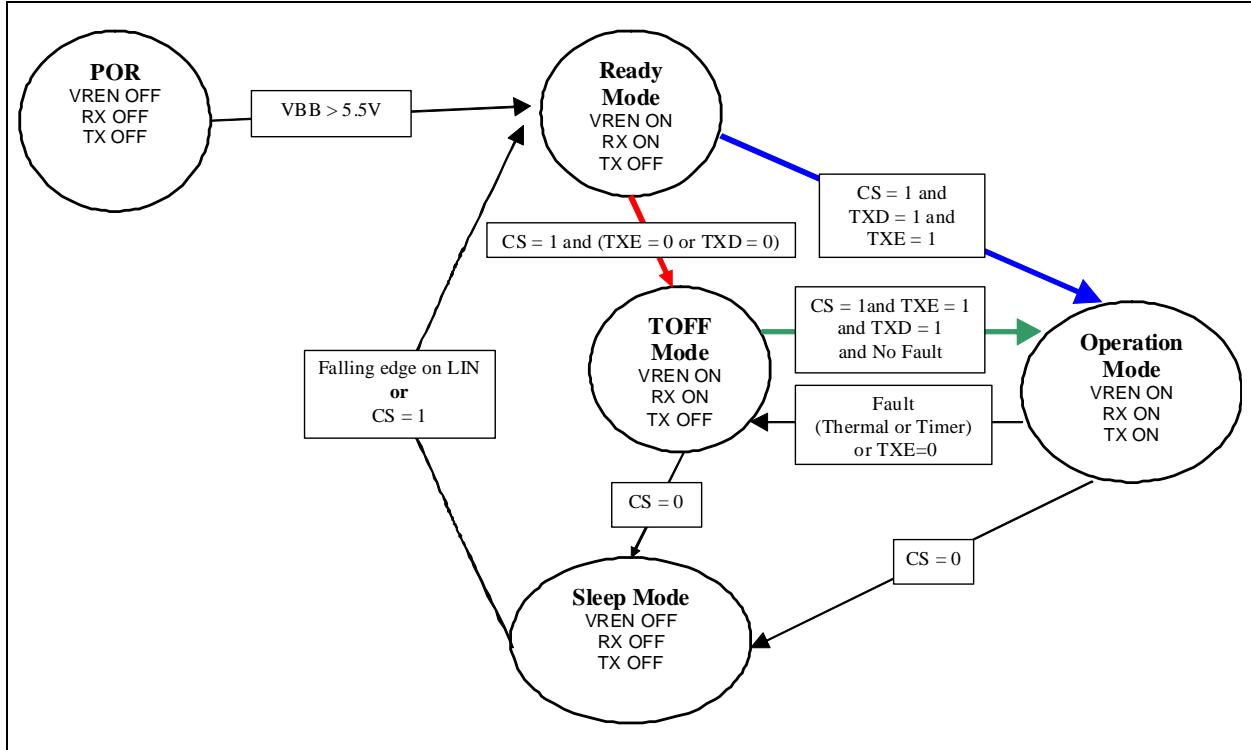

FIGURE 1-3: OPERATIONAL MODES STATE DIAGRAM – MCP2004



Note: While the MCP2003/4 is in thermal shutdown, TXD should not be actively driven high or it may power internal logic through the ESD diodes and may damage the device.

TABLE 1-1: OVERVIEW OF OPERATIONAL MODES

State	Transmitter	Receiver	Vren	Operation	Comments
POR	OFF	OFF	OFF	Read CS, if low, then Ready; if high, Operational mode	
Ready	OFF	ON	ON	If CS high level, then Operation mode	Bus Off state
Operation	ON	ON	ON	If CS low level, then Power Down; If FAULT/TXE low level, then Transmitter Off mode	Normal Operation mode
Power Down	OFF	Activity Detect	OFF	On LIN bus falling, go to Ready mode. On CS high level, go to Operation mode	Low Power mode
Transmitter Off	OFF	ON	ON	If CS low level, then Power Down; If FAULT/TXE and TXD high, then Operation mode	FAULT/TXE only available on MCP2004

MCP2003/4

1.4 Typical Applications

EXAMPLE 1-1: TYPICAL MCP2003 APPLICATION

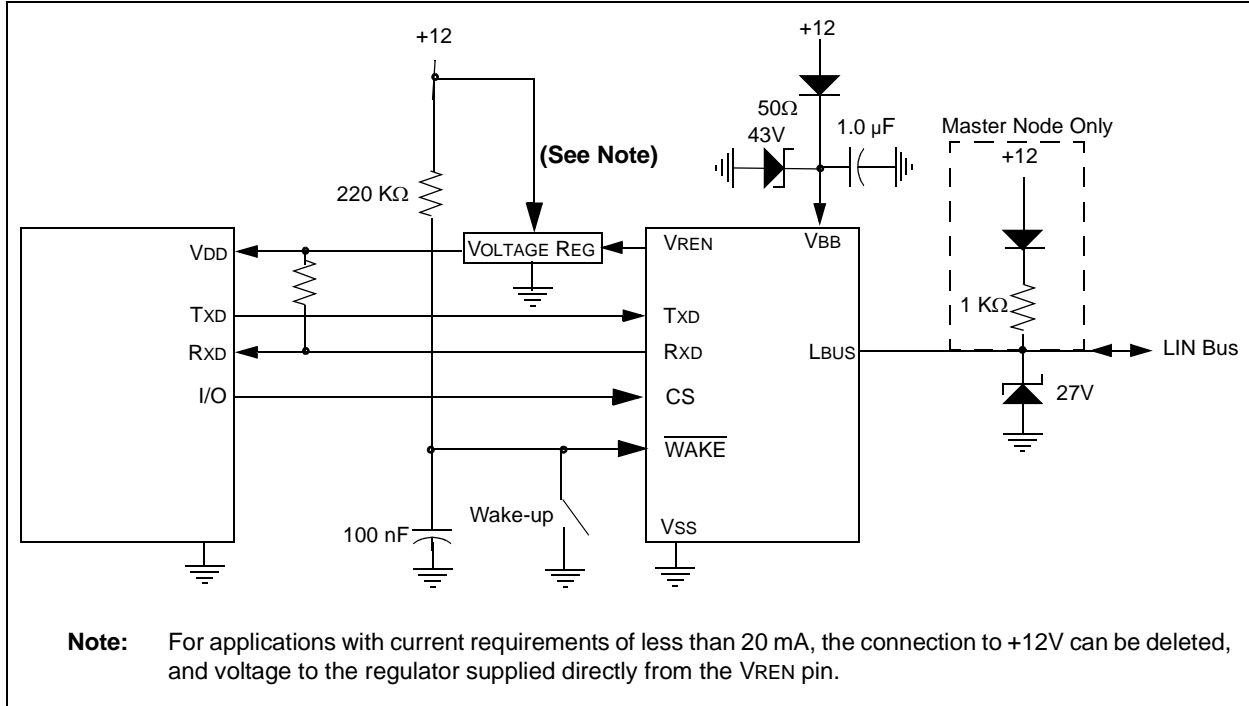

EXAMPLE 1-2: TYPICAL MCP2004 APPLICATION

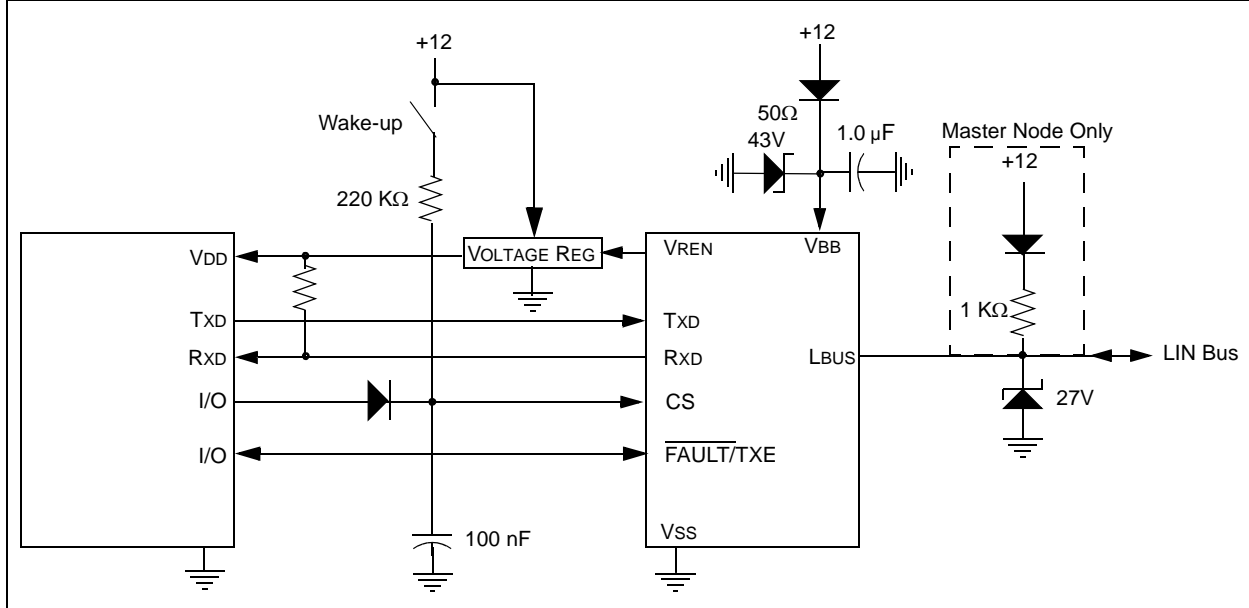

EXAMPLE 1-3: TYPICAL LIN NETWORK CONFIGURATION

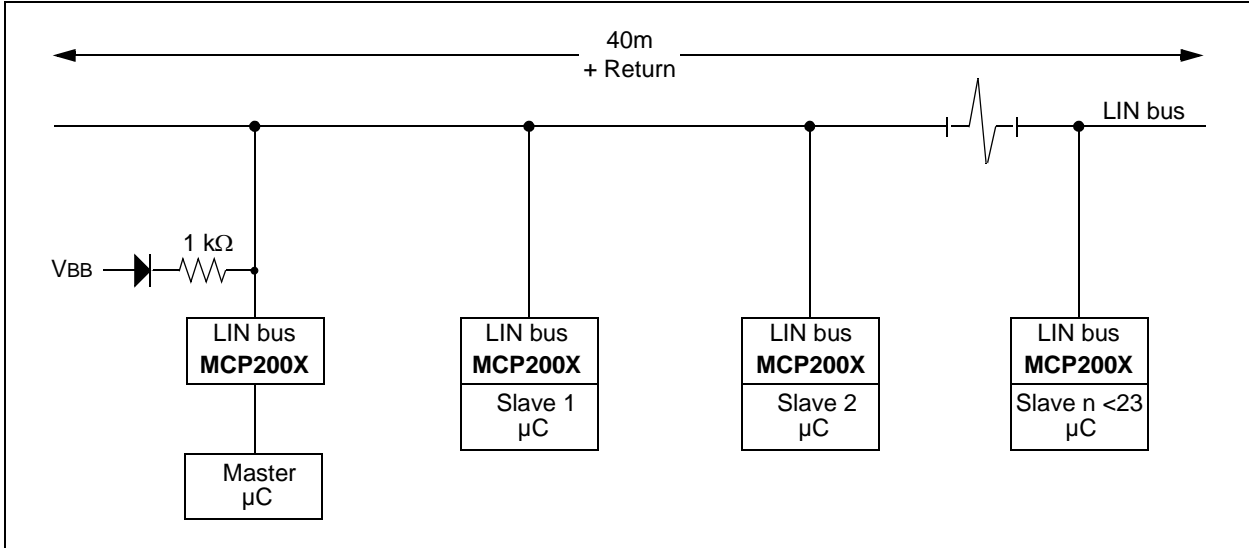

MCP2003/4

1.5 Pin Descriptions

TABLE 1-1: PINOUT DESCRIPTIONS

Pin Name	8-Pin PDIP, SOIC	8-Pin DFN	MCP2003	MCP2004
			Normal Operation	Normal Operation
RXD	1	1	Receive Data Output (OD)	Receive Data Output (OD)
CS	2	2	Chip Select (TTL)	Chip Select/Local WAKE (TTL)
WAKE (MCP2003 only) FAULT/TXE (MCP2004 only)	3	3	Wake up, HV tolerant	Fault Detect Output (OD) Transmitter Enable (TTL)
TXD	4	4	Transmit Data Input (TTL)	Transmit Data Input (TTL)
VSS	5	5	Ground	Ground
LBUS	6	6	LIN bus (bidirectional)	LIN bus (bidirectional)
VBB	7	7	Battery positive	Battery positive
VREN	8	8	Voltage Regulator Enable Output	Voltage Regulator Enable Output
EP	—	9	Exposed Thermal Pad. Do not electrically connect or connect to Vss	Exposed Thermal Pad. Do not electrically connect or connect to Vss

Legend: TTL = TTL Input Buffer; OD = Open-Drain Output

1.5.1 RECEIVE DATA OUTPUT (RXD)

The Receive Data Output pin is an open drain (OD) output and follows the state of the LIN pin.

1.5.2 CS (CHIP SELECT)

Chip Select Input pin. An internal pull-down resistor will keep the CS pin low. This is done to ensure that no disruptive data will be present on the bus while the microcontroller is executing a Power-on Reset and an I/O initialization sequence. The pin must detect a high level to activate the transmitter.

If CS = 0 when the VBB supply is turned on, the device stays in Ready mode. In Ready mode, the receiver is on and the LIN transmitter driver is off.

If CS = 1 when the VBB supply is turned on, the device will proceed to the Operation mode as soon as internal voltages stabilize.

This pin may also be used as a local wake-up input (Refer to [Example 1-1](#)). In this implementation, the microcontroller I/O controlling the CS should be converted to a high-impedance input allowing the internal pull-down resistor will keep CS low. An external switch, or other source, can then wake-up both the transceiver and the microcontroller (if powered).

Note: It is not recommended to tie CS high as this can result the MCP2003/4 entering Operation mode before the microcontroller is initialized and may result in unintentional LIN traffic.

1.5.3 WAKE UP INPUT ($\overline{\text{WAKE}}$)

This pin is only available on the MCP2003.

The $\overline{\text{WAKE}}$ pin has an internal 800K pull up to VBB. A falling edge on the $\overline{\text{WAKE}}$ pin causes the device to wake from Power Down mode. Upon waking, the MCP2003 will enter Ready mode

1.5.4 $\overline{\text{FAULT/TXE}}$

This pin is only available on the MCP2004. This pin is bidirectional and allows disabling of the transmitter, as well as fault reporting related to disabling the transmitter. This pin is an open-drain output with states as defined in [Table 1-2](#). The transmitter is disabled whenever this pin is low ('0'), either from an internal Fault condition or by an external drive. While the transmitter is disabled, the internal 30 k Ω pull-up resistor on the LBUS pin is also disconnected to reduce current.

Note: The $\overline{\text{FAULT/TXE}}$ pin is true ('0') whenever the internal circuits have detected a short or thermal excursion and have disabled the LBUS output driver.

TABLE 1-2: FAULT/TXE TRUTH TABLE

TXD In	RXD Out	LINBUS I/O	Thermal Override	FAULT/TXE		Definition
				External Input	Driven Output	
L	H	VBB	OFF	H	L	FAULT, TXD driven low, LINBUS shorted to VBB (Note 1)
H	H	VBB	OFF	H	H	OK
L	L	GND	OFF	H	H	OK
H	L	GND	OFF	H	H	OK, data is being received from the LINBUS
x	x	VBB	ON	H	L	FAULT, Transceiver in thermal shutdown
x	x	VBB	x	L	x	NO FAULT, the CPU is commanding the transceiver to turn off the transmitter driver

Legend: x = don't care

Note 1: The FAULT/TXE is valid after approximately 25 μ s after TXD falling edge. This is to eliminate false fault reporting during bus propagation delays.

1.5.5 TRANSMIT DATA INPUT (TXD)

The Transmit Data Input pin has an internal pull-up. The LIN pin is low (dominant) when TXD is low, and high (recessive) when TXD is high.

For extra bus security, TXD is internally forced to '1' whenever the transmitter is disabled regardless of external TXD voltage.

1.5.5.1 TXD Dominant Timeout

If TXD is driven low longer than approximately 10 ms, the L_{BUS} pin is switched to Recessive mode and the part enters TOFF mode. This is to prevent the LIN node from permanently driving the LIN Bus dominant. The transmitter is re-enabled on the TXD rising edge.

1.5.6 GROUND (Vss)

This is the Ground pin.

1.5.7 LIN BUS (L_{BUS})

The bidirectional LIN Bus pin (L_{BUS}) is controlled by the TXD input. L_{BUS} has a current limited open collector output. To reduce EMI, the edges during the signal changes are slope controlled and include corner rounding control for both falling and rising edges.

The internal LIN receiver observes the activities on the LIN bus, and matches the output signal RXD to follow the state of the L_{BUS} pin.

1.5.7.1 Bus Dominant Timer

The Bus Dominant Timer is an internal timer that deactivates the L_{BUS} transmitter after approximately 25 milliseconds of dominant state on the L_{BUS} pin. The timer is reset on any recessive L_{BUS} state.

The LIN bus transmitter will be re-enabled after a recessive state on the L_{BUS} pin as long as CS is high. Disabling can be caused by the LIN bus being externally held dominant, or by TXD being driven low. Additionally, on the MCP2004, the FAULT pin will be driven low to indicate the Transmitter Off state.

1.5.8 BATTERY (VBB)

This is the Battery Positive Supply Voltage pin.

1.5.9 VOLTAGE REGULATOR ENABLE OUTPUT (VREN)

This is the External Voltage Regulator Enable pin. Open source output is pulled high to VBB in all modes, except Power Down.

1.5.10 EXPOSED THERMAL PAD (EP)

Do not electrically connect, or connect to Vss.

MCP2003/4

NOTES:

2.0 ELECTRICAL CHARACTERISTICS

2.1 Absolute Maximum Ratings†

V _{IN} DC Voltage on RXD, TXD, $\overline{\text{FAULT}}/\text{TXE}$	-0.3 to +30V
V _{IN} DC Voltage on CS, $\overline{\text{WAKE}}$ and VREN	-0.3 to +30V
V _{BB} Battery Voltage, continuous	-0.3 to +30V
V _{BB} Battery Voltage, non-operating (LIN bus recessive, t < 60s)	-0.3 to +43V
V _{BB} Battery Voltage, transient ISO 7637 Test 1	-200V
V _{BB} Battery Voltage, transient ISO 7637 Test 2a	+150V
V _{BB} Battery Voltage, transient ISO 7637 Test 3a	-300V
V _{BB} Battery Voltage, transient ISO 7637 Test 3b	+200V
V _{LBUS} Bus Voltage, continuous.....	-18 to +30V
V _{LBUS} Bus Voltage, transient (Note 1).....	-27 to +43V
I _{LBUS} Bus Short Circuit Current Limit	200 mA
ESD protection on LIN, V _{BB} (IEC 61000-4-2) (Note 2).....	±8 KV
ESD protection on LIN, V _{BB} (Human Body Model) (Note 3).....	±8 KV
ESD protection on all other pins (Human Body Model) (Note 3)	±4 KV
ESD protection on all pins (Charge Device Model) (Note 4)	±2 KV
ESD protection on all pins (Machine Model) (Note 5).....	±200V
Maximum Junction Temperature	150°C
Storage Temperature	-65 to +150°C

Note 1: ISO 7637/1 load dump compliant (t < 500 ms).

2: According to IEC 61000-4-2, 330 ohm, 150 pF and Transceiver EMC Test Specifications [2] to [4].

3: According to AEC-Q100-002/JESD22-A114.

4: According to AEC-Q100-011B.

5: According to AEC-Q100-003/JESD22-A115.

† **NOTICE:** Stresses above those listed under “Absolute Maximum Ratings” may cause permanent damage to the device. This is a stress rating only and functional operation of the device at those or any other conditions above those indicated in the operational listings of this specification is not implied. Exposure to maximum rating conditions for extended periods may affect device reliability.

MCP2003/4

2.2 DC Specifications

DC Specifications	Electrical Characteristics:					
	Unless otherwise indicated, all limits are specified for: V _{BB} = 6.0V to 27.0V T _A = -40°C to +125°C					
Parameter	Sym	Min.	Typ.	Max.	Units	Conditions
Power						
V _{BB} Quiescent Operating Current	IBBQ		90	150	μA	Operating Mode, bus recessive (Note 1)
V _{BB} Transmitter-off Current	IBBTO	—	75	120	μA	Transmitter off, bus recessive (Note 1)
V _{BB} Power Down Current	IBBPD	—	5	15	μA	Transmitter off, bus recessive (Note 1)
V _{BB} Current with V _{SS} Floating	IBBNOGND	-1	—	1	mA	V _{BB} = 12V, GND to V _{BB} , V _{LIN} = 0-18V
Microcontroller Interface						
High Level Input Voltage (T _{xD} , FAULT/TX _E)	V _{IH}	2.0	—	5.3	V	
Low Level Input Voltage (T _{xD} , FAULT/TX _E)	V _{IL}	-0.3	—	0.8	V	
High Level Input Current (T _{xD} , FAULT/TX _E)	I _{IH}	-2.5	—	—	μA	Input voltage = 4.0V
Low Level Input Current (T _{xD} , FAULT/TX _E)	I _{IL}	-10	—	—	μA	Input voltage = 0.5V
High Level Voltage (V _{REN})	V _{HVREN}	-0.3	—	V _{BB} +0.3		
High Level Output Current (V _{REN})	I _{HVREN}	-20	—	-10	mA	Output voltage = V _{BB} -0.5V
High Level Input Voltage (CS)	V _{IH}	2.0	—	V _{BB}	V	Through a current limiting resistor
Low Level Input Voltage (CS)	V _{IL}	-0.3	—	0.8	V	
High Level Input Current (CS)	I _{IH}	-10.0	—	10.0	μA	Input voltage = 4.0V
Low Level Input Current (CS)	I _{IL}	-5.0	—	5.0	μA	Input voltage = 0.5V
Low Level Input Voltage (WAKE)	V _{IL}	V _{BB} - 4.0V	—	—	V	
Low Level Output Voltage (R _{xD})	V _{OL}	—	—	0.4	V	I _{IN} = 2 mA
High Level Output Current (R _{xD})	I _{OH}	-1	—	-1	μA	V _{LIN} - V _{BB} , V _{RxD} = 5.5V

Note 1: Internal current limited. 2.0 ms maximum recovery time (R_{LBUS} = 0Ω, TX = 0.4 V_{REG}, V_{LBUS} = V_{BB}).

2: Node has to sustain the current that can flow under this condition; bus must be operational under this condition.

2.2 DC Specifications (Continued)

DC Specifications	Electrical Characteristics: Unless otherwise indicated, all limits are specified for: $V_{BB} = 6.0V$ to $27.0V$ $T_A = -40^{\circ}C$ to $+125^{\circ}C$					
	Parameter	Sym	Min.	Typ.	Max.	Units
Bus Interface						
High Level Input Voltage	$V_{IH}(L_{BUS})$	$0.6 V_{BB}$	—	18	V	Recessive state
Low Level Input Voltage	$V_{IL}(L_{BUS})$	-8	—	$0.4 V_{BB}$	V	Dominant state
Input Hysteresis	V_{HYS}	—	—	$0.175 V_{BB}$	V	$V_{IH}(L_{BUS}) - V_{IL}(L_{BUS})$
Low Level Output Current	$I_{OL}(L_{BUS})$	40	—	200	mA	Output voltage = $0.1 V_{BB}$, $V_{BB} = 12V$
Pull-up Current on Input	$I_{PU}(L_{BUS})$	5	—	180	μA	$\sim 30 k\Omega$ internal pull-up @ $V_{IH}(L_{BUS}) = 0.7 V_{BB}$
Short Circuit Current Limit	ISC	50	—	200	mA	(Note 1)
High Level Output Voltage	$V_{OH}(L_{BUS})$	$0.9 V_{BB}$	—	V_{BB}	V	
Driver Dominant Voltage	V_{LOSUP}	—	—	1.2	V	$V_{BB} = 7V$, $R_{LOAD} = 500\Omega$
Driver Dominant Voltage	V_{HISUP}	—	—	2.0	V	$V_{BB} = 18V$, $R_{LOAD} = 500\Omega$
Driver Dominant Voltage	$V_{LOSUP-1K}$	0.6	—	—	V	$V_{BB} = 7V$, $R_{LOAD} = 1 k\Omega$
Driver Dominant Voltage	$V_{HISUP-1K}$	0.8	—	—	V	$V_{BB} = 18V$, $R_{LOAD} = 1 k\Omega$
Input Leakage Current (at the receiver during dominant bus level)	$I_{BUS_PAS_DOM}$	-1	-0.4	—	mA	Driver off, $V_{BUS} = 0V$, $V_{BB} = 12V$
Input Leakage Current (at the receiver during recessive bus level)	$I_{BUS_PAS_REC}$	—	12	20	μA	Driver off, $8V < V_{BB} < 18V$ $8V < V_{BUS} < 18V$ $V_{BUS} \geq V_{BB}$
Leakage Current (disconnected from ground)	$I_{BUS_NO_GND}$	-10	1.0	+10	μA	$GND_{DEVICE} = V_{BB}$, $0V < V_{BUS} < 18V$, $V_{BB} = 12V$
Leakage Current (disconnected from V_{BB})	I_{BUS}	—	—	10	μA	$V_{BB} = GND$, $0 < V_{BUS} < 18V$, $T_A = -40^{\circ}C$ to $+85^{\circ}C$ (Note 2)
Receiver Center Voltage	V_{BUS_CNT}	$0.475 V_{BB}$	$0.5 V_{BB}$	$0.525 V_{BB}$	V	$V_{BUS_CNT} = (V_{IL}(L_{BUS}) + V_{IH}(L_{BUS}))/2$
Slave Termination	RSLAVE	20	30	47	$k\Omega$	

Note 1: Internal current limited. 2.0 ms maximum recovery time ($R_{L_{BUS}} = 0\Omega$, $T_X = 0.4 V_{REG}$, $V_{L_{BUS}} = V_{BB}$).

2: Node has to sustain the current that can flow under this condition; bus must be operational under this condition.

MCP2003/4

2.3 AC Specifications

AC CHARACTERISTICS							V _{BB} = 6.0V to 27.0V; T _A = -40°C to +125°C						
Parameter	Sym	Min.	Typ.	Max.	Units	Test Conditions							
Bus Interface – Constant Slope Time Parameters													
Slope rising and falling edges	tslope	3.5	—	22.5	μs	7.3V ≤ V _{BB} ≤ 18V							
Propagation Delay of Transmitter	ttranspd	—	—	4.0	μs	ttranspd = max (ttranspdr or ttranspdf)							
Propagation Delay of Receiver	trecpd	—	—	6.0	μs	trecpd = max (trecpdr or trecpdf)							
Symmetry of Propagation Delay of Receiver rising edge w.r.t. falling edge	trecsym	-2.0	—	2.0	μs	trecsym = max (trecpdf – trecpdr)							
Symmetry of Propagation Delay of Transmitter rising edge w.r.t. falling edge	ttrans-sym	-2.0	—	2.0	μs	ttranssym = max (ttranspdf - ttranspdr)							
Time to sample of FAULT/ TXE for bus conflict reporting	tfault	—	—	32.5	μs	tfault = max (ttranspd + tslope + trecpd)							
Duty Cycle 1 @20.0 kbit/sec		39.6	—	—	%tbit	Cbus;Rbus conditions: 1 nF; 1 kW 6.8 nF; 660W 10 nF; 500W THrec(max) = 0.744 x V _{BB} , THdom(max) = 0.581 x V _{BB} , V _{BB} = 7.0V-18V; tbit = 50 μs D1 = tbus_rec(min) / 2 x tbit)							
Duty Cycle 2 @20.0 kbit/sec		—	—	58.1	%tbit	Cbus;Rbus conditions: 1 nF; 1 kW 6.8 nF; 660W 10 nF; 500W THrec(max) = 0.284 x V _{BB} , THdom(max) = 0.422 x V _{BB} , V _{BB} = 7.6V-18V; tbit = 50 μs D2 = tbus_rec(max) / 2 x tbit)							
Duty Cycle 3 @10.4 kbit/sec		41.7	—	—	%tbit	Cbus;Rbus conditions: 1 nF; 1 kW 6.8 nF; 660W 10 nF; 500W THrec(max) = 0.778 x V _{BB} , THdom(max) = 0.616 x V _{BB} , V _{BB} = 7.0V-18V; tbit = 96 μs D3 = tbus_rec(min) / 2 x tbit)							
Duty Cycle 4 @10.4 kbit/sec		—	—	59.0	%tbit	Cbus;Rbus conditions: 1 nF; 1 kW 6.8 nF; 660W 10 nF; 500W THrec(max) = 0.251 x V _{BB} , THdom(max) = 0.389 x V _{BB} , V _{BB} = 7.6V-18V; tbit = 96 μs D4 = tbus_rec(max) / 2 x tbit)							
Wake-up Timing													
Bus Activity Debounce time	tBDB	5		20	μs	Bus debounce time, 10 μs typical							
Bus Activity to Vren on	tBACTVE	35		150	μs	After Bus debounce time, 52 μs typical							
WAKE to Vren on	tWAKE			150	μs								
Chip Select to Vren on	tCSOR	—		150	μs	Vren floating							
Chip Select to Vren off	tCSPD	—		80	μs	Vren floating							

2.4 Thermal Specifications

THERMAL CHARACTERISTICS					
Parameter	Symbol	Typ	Max	Units	Test Conditions
Recovery Temperature	$\theta_{RECOVERY}$	+140	—	°C	
Shutdown Temperature	$\theta_{SHUTDOWN}$	+150	—	°C	
Short Circuit Recovery Time	tTHERM	1.5	5.0	ms	
Thermal Package Resistances					
Thermal Resistance, 8L-DFN	θ_{JA}	35.7	—	°C/W	
Thermal Resistance, 8L-PDIP	θ_{JA}	89.3	—	°C/W	
Thermal Resistance, 8L-SOIC	θ_{JA}	149.5	—	°C/W	

Note 1: The maximum power dissipation is a function of T_{JMAX} , θ_{JA} and ambient temperature T_A . The maximum allowable power dissipation at an ambient temperature is $P_D = (T_{JMAX} - T_A) \theta_{JA}$. If this dissipation is exceeded, the die temperature will rise above 150°C and the MCP2003/4 will go into thermal shutdown.

MCP2003/4

2.5 Typical Performance Curves

Note: The graphs and tables provided following this note are a statistical summary based on a limited number of samples and are provided for informational purposes only. The performance characteristics listed herein are not tested or guaranteed. In some graphs or tables, the data presented may be outside the specified operating range (e.g., outside specified power supply range) and therefore outside the warranted range.

Note: Unless otherwise indicated, $V_{BB} = 6.0V$ to $18.0V$, $T_A = -40^{\circ}C$ to $+125^{\circ}C$.

FIGURE 2-1: TYPICAL IBBQ

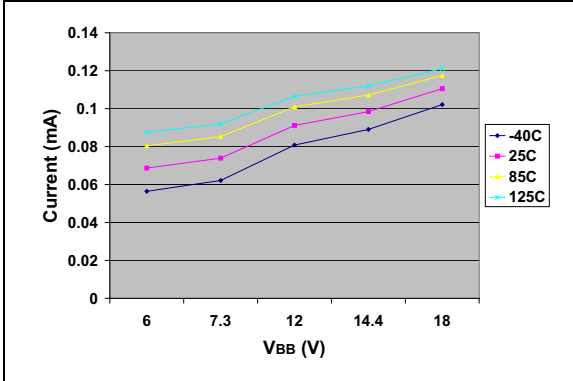

FIGURE 2-3: TYPICAL IBBTO

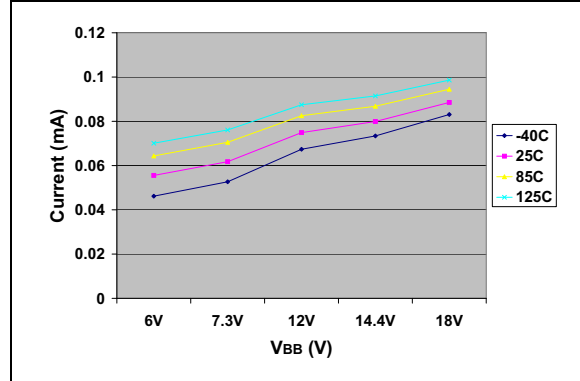
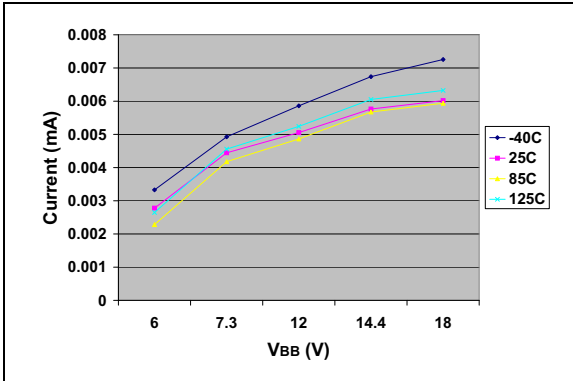

FIGURE 2-2: TYPICAL IBBPD



2.6 Timing Diagrams and Specifications

FIGURE 2-4: BUS TIMING DIAGRAM

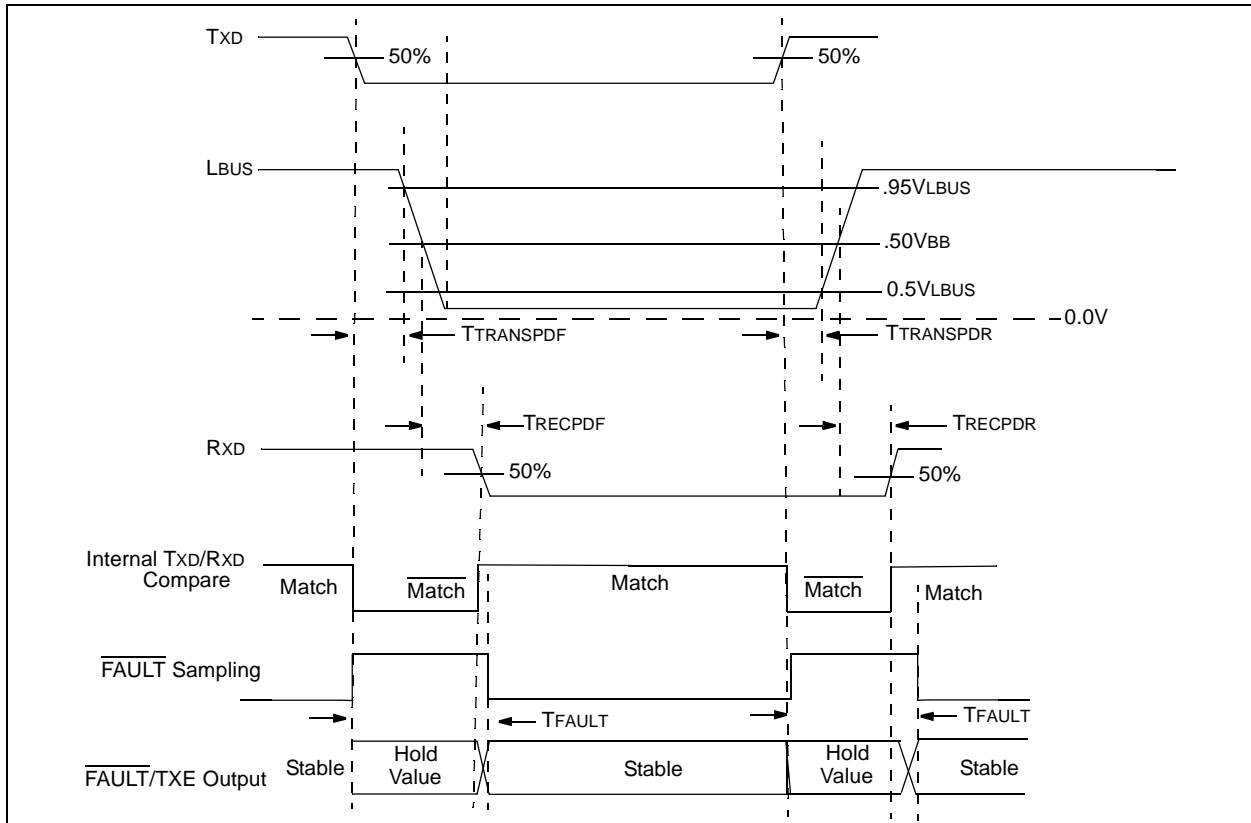

FIGURE 2-5: CS TO VREN TIMING DIAGRAM

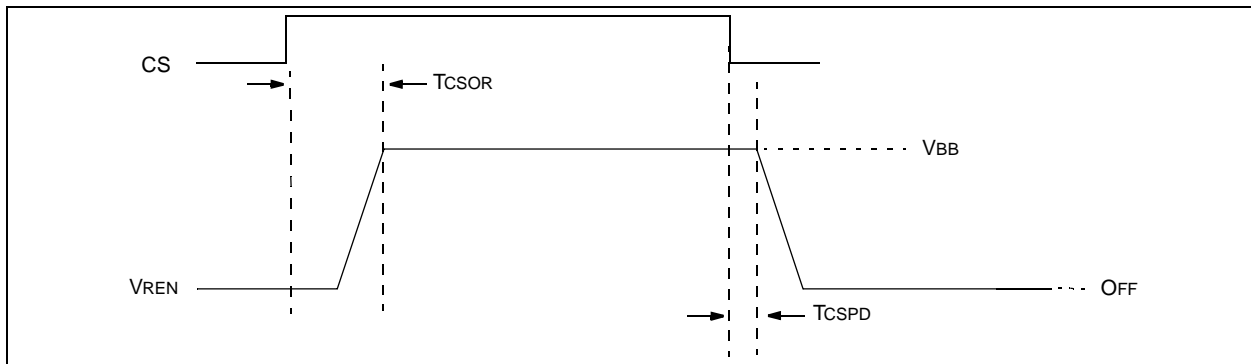
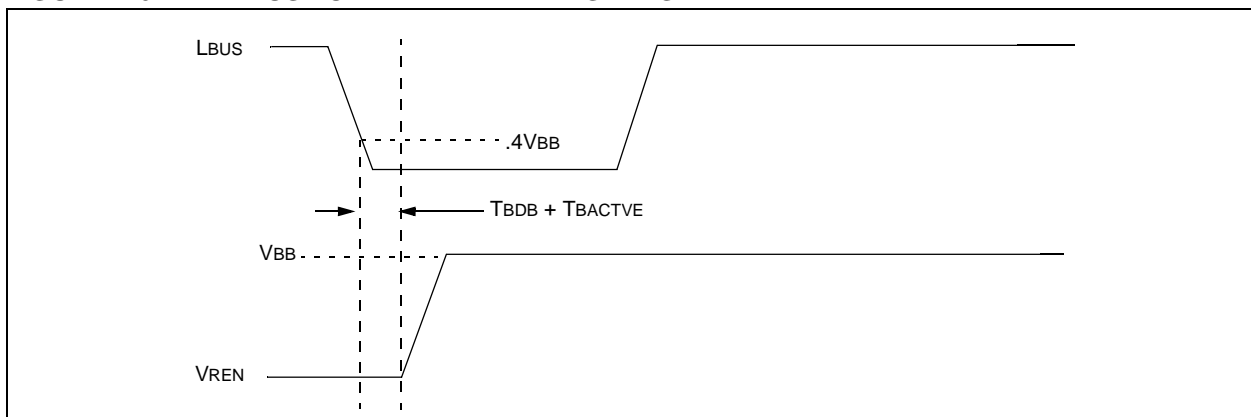

FIGURE 2-6: BUS TO VREN WAKE TIMING DIAGRAM



MCP2003/4

NOTES:

3.0 PACKAGING INFORMATION

3.1 Package Marking Information

8-Lead DFN (4x4)

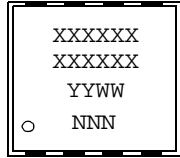

Example:

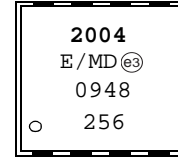

8-Lead PDIP (300 mil)

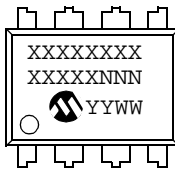

Example:

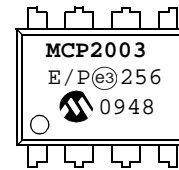

8-Lead SOIC (150 mil)

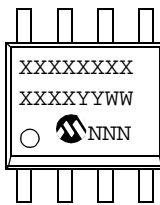

Example:

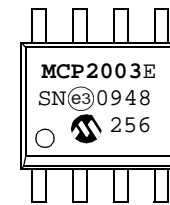

Legend:	XX...X	Customer-specific information
	Y	Year code (last digit of calendar year)
	YY	Year code (last 2 digits of calendar year)
	WW	Week code (week of January 1 is week '01')
	NNN	Alphanumeric traceability code
	(e3)	Pb-free JEDEC designator for Matte Tin (Sn)
	*	This package is Pb-free. The Pb-free JEDEC designator (e3) can be found on the outer packaging for this package.

Note: In the event the full Microchip part number cannot be marked on one line, it will be carried over to the next line, thus limiting the number of available characters for customer-specific information.

8-Lead Plastic Dual Flat, No Lead Package (MD) – 4x4x0.9 mm Body [DFN]

Note: For the most current package drawings, please see the Microchip Packaging Specification located at <http://www.microchip.com/packaging>

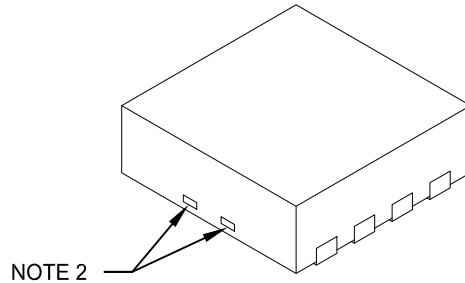

		MILLIMETERS		
Units				
Dimension Limits		MIN	NOM	MAX
Number of Pins	N	8		
Pitch	e	0.80 BSC		
Overall Height	A	0.80	0.90	1.00
Standoff	A1	0.00	0.02	0.05
Contact Thickness	A3	0.20 REF		
Overall Length	D	4.00 BSC		
Exposed Pad Width	E2	2.60	2.70	2.80
Overall Width	E	4.00 BSC		
Exposed Pad Length	D2	3.40	3.50	3.60
Contact Width	b	0.25	0.30	0.35
Contact Length	L	0.30	0.40	0.50
Contact-to-Exposed Pad	K	0.20	-	-

Notes:

1. Pin 1 visual index feature may vary, but must be located within the hatched area.
2. Package may have one or more exposed tie bars at ends.
3. Package is saw singulated
4. Dimensioning and tolerancing per ASME Y14.5M
 - BSC: Basic Dimension. Theoretically exact value shown without tolerances.
 - REF: Reference Dimension, usually without tolerance, for information purposes only.

Microchip Technology Drawing C04-131E Sheet 2 of 2

MCP2003/4

8-Lead Plastic Dual Flat, No Lead Package (MD) - 4x4x0.9 mm Body [DFN]

Note: For the most current package drawings, please see the Microchip Packaging Specification located at <http://www.microchip.com/packaging>

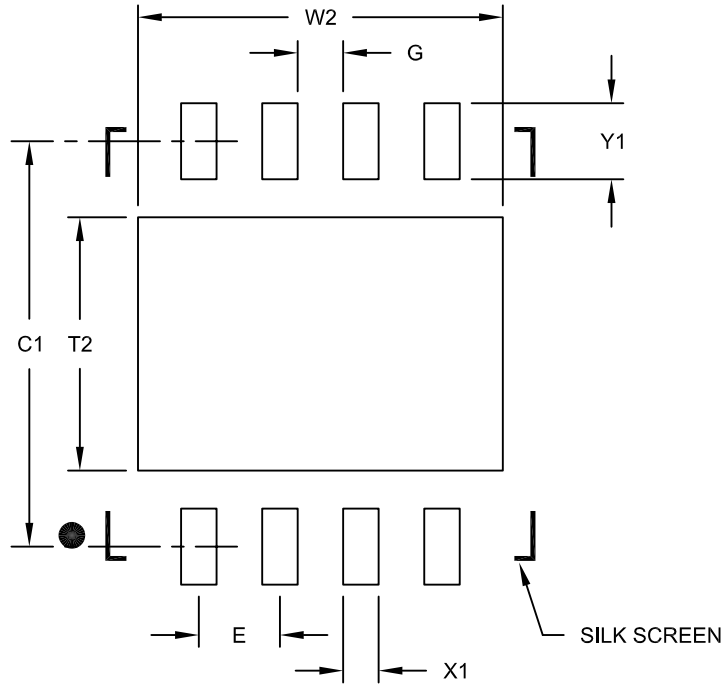

RECOMMENDED LAND PATTERN

Dimension Limits	Units	MILLIMETERS		
		MIN	NOM	MAX
Contact Pitch	E	0.80 BSC		
Optional Center Pad Width	W2			3.60
Optional Center Pad Length	T2			2.50
Contact Pad Spacing	C1		4.00	
Contact Pad Width (X8)	X1			0.35
Contact Pad Length (X8)	Y1			0.75
Distance Between Pads	G	0.45		

Notes:

1. Dimensioning and tolerancing per ASME Y14.5M

BSC: Basic Dimension. Theoretically exact value shown without tolerances.

Microchip Technology Drawing No. C04-2131C

8-Lead Plastic Dual In-Line (P) – 300 mil Body [PDIP]

Note: For the most current package drawings, please see the Microchip Packaging Specification located at <http://www.microchip.com/packaging>

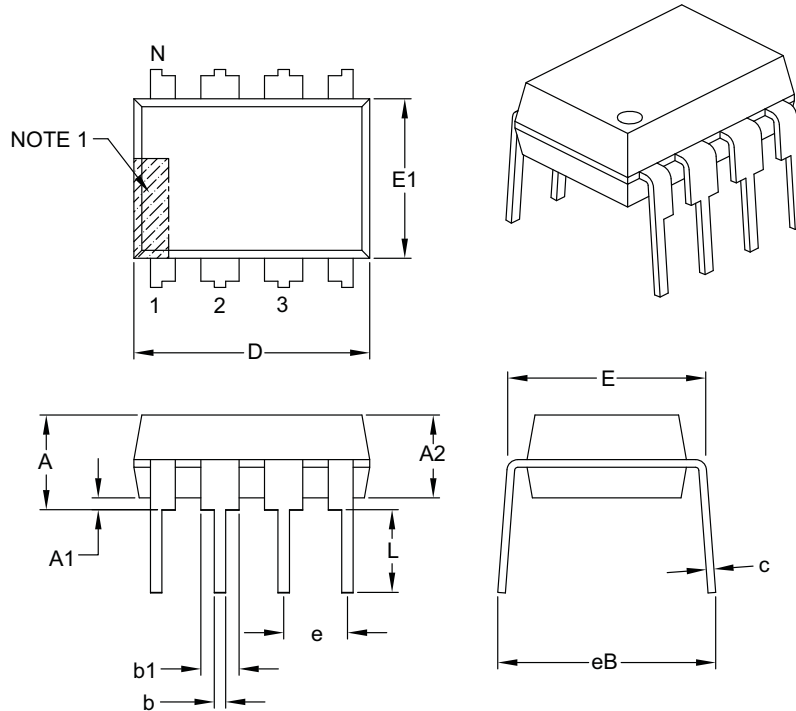

Dimension Limits	Units	INCHES		
		MIN	NOM	MAX
Number of Pins	N	8		
Pitch	e	.100 BSC		
Top to Seating Plane	A	–	–	.210
Molded Package Thickness	A2	.115	.130	.195
Base to Seating Plane	A1	.015	–	–
Shoulder to Shoulder Width	E	.290	.310	.325
Molded Package Width	E1	.240	.250	.280
Overall Length	D	.348	.365	.400
Tip to Seating Plane	L	.115	.130	.150
Lead Thickness	c	.008	.010	.015
Upper Lead Width	b1	.040	.060	.070
Lower Lead Width	b	.014	.018	.022
Overall Row Spacing §	eB	–	–	.430

Notes:

1. Pin 1 visual index feature may vary, but must be located with the hatched area.
2. § Significant Characteristic.
3. Dimensions D and E1 do not include mold flash or protrusions. Mold flash or protrusions shall not exceed .010" per side.
4. Dimensioning and tolerancing per ASME Y14.5M.

BSC: Basic Dimension. Theoretically exact value shown without tolerances.

Microchip Technology Drawing C04-018B

MCP2003/4

8-Lead Plastic Small Outline (SN) – Narrow, 3.90 mm Body [SOIC]

Note: For the most current package drawings, please see the Microchip Packaging Specification located at <http://www.microchip.com/packaging>

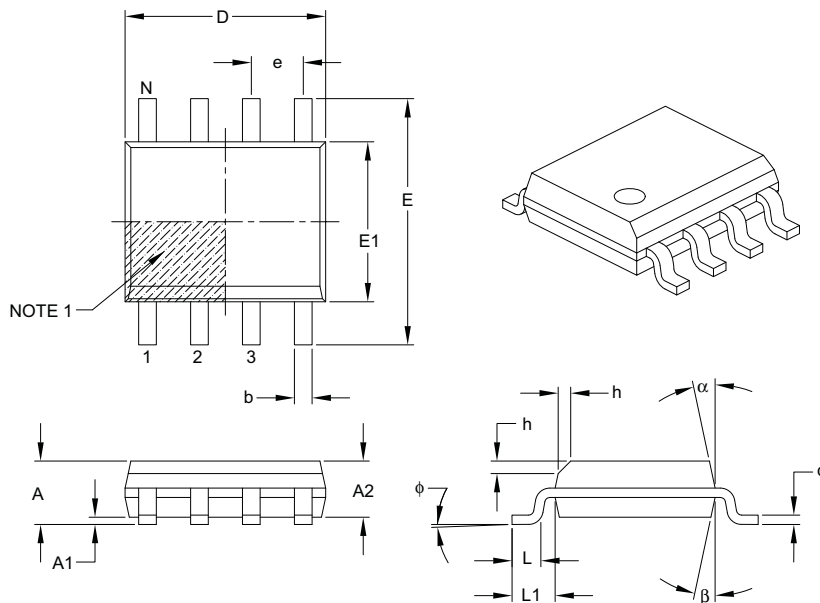

Dimension Limits	Units	MILLIMETERS		
		MIN	NOM	MAX
Number of Pins	N	8		
Pitch	e	1.27 BSC		
Overall Height	A	–	–	1.75
Molded Package Thickness	A2	1.25	–	–
Standoff §	A1	0.10	–	0.25
Overall Width	E	6.00 BSC		
Molded Package Width	E1	3.90 BSC		
Overall Length	D	4.90 BSC		
Chamfer (optional)	h	0.25	–	0.50
Foot Length	L	0.40	–	1.27
Footprint	L1	1.04 REF		
Foot Angle	ϕ	0°	–	8°
Lead Thickness	c	0.17	–	0.25
Lead Width	b	0.31	–	0.51
Mold Draft Angle Top	α	5°	–	15°
Mold Draft Angle Bottom	β	5°	–	15°

Notes:

- Pin 1 visual index feature may vary, but must be located within the hatched area.
- § Significant Characteristic.
- Dimensions D and E1 do not include mold flash or protrusions. Mold flash or protrusions shall not exceed 0.15 mm per side.
- Dimensioning and tolerancing per ASME Y14.5M.

BSC: Basic Dimension. Theoretically exact value shown without tolerances.

REF: Reference Dimension, usually without tolerance, for information purposes only.

Microchip Technology Drawing C04-057B

8-Lead Plastic Small Outline (SN) – Narrow, 3.90 mm Body [SOIC]

Note: For the most current package drawings, please see the Microchip Packaging Specification located at <http://www.microchip.com/packaging>

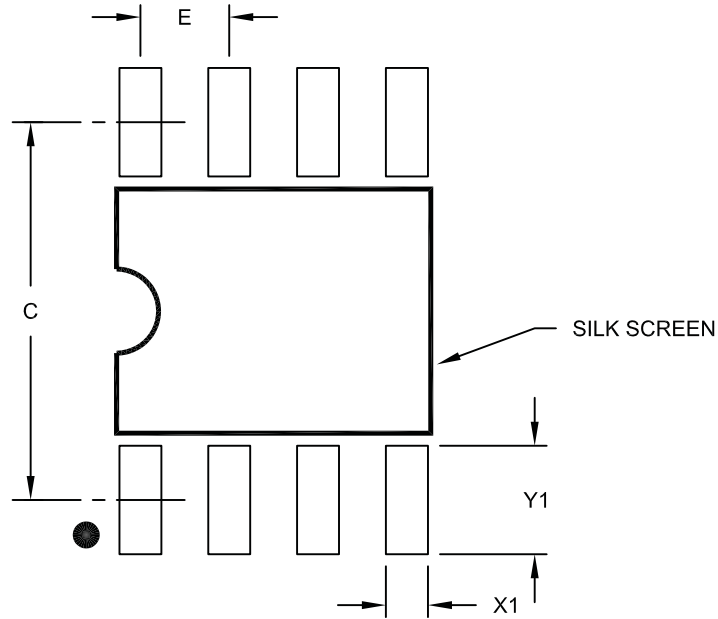

RECOMMENDED LAND PATTERN

Dimension Limits	Units	MILLIMETERS		
		MIN	NOM	MAX
Contact Pitch	E	1.27 BSC		
Contact Pad Spacing	C		5.40	
Contact Pad Width (X8)	X1			0.60
Contact Pad Length (X8)	Y1			1.55

Notes:

1. Dimensioning and tolerancing per ASME Y14.5M

BSC: Basic Dimension. Theoretically exact value shown without tolerances.

Microchip Technology Drawing No. C04-2057A

MCP2003/4

NOTES:

APPENDIX A: REVISION HISTORY

Revision A (March 2010)

- Original Release of this Document.

MCP2003/4

NOTES:

PRODUCT IDENTIFICATION SYSTEM

To order or obtain information, e.g., on pricing or delivery, refer to the factory or the listed sales office.

<u>PART NO.</u>	<u>X</u>	<u>/XX</u>	
Device	Temperature Range	Package	
<p>Device: MCP2003: LIN Transceiver with Voltage Regulator MCP2003T: LIN Transceiver with Voltage Regulator (Tape and Reel) (DFN and SOIC) MCP2004: LIN Transceiver with Voltage Regulator MCP2004T: LIN Transceiver with Voltage Regulator (Tape and Reel) (DFN and SOIC)</p> <p>Temperature Range: E = -40°C to +125°C</p> <p>Package: MD = Plastic Micro Small Outline (4x4), 8-lead P = Plastic DIP (300 mil Body), 8-lead, 14-lead SN = Plastic SOIC, (150 mil Body), 8-lead</p>			
			<p>Examples:</p> <p>a) MCP2003-E/MD: Extended Temperature, 8L-DFN pkg. b) MCP2003-E/P: Extended Temperature, 8L-PDIP pkg. c) MCP2003-E/SN: Extended Temperature, 8L-SOIC pkg. d) MCP2003T-E/MD: Tape and Reel, Extended Temperature, 8L-DFN pkg. e) MCP2003T-E/SN: Tape and Reel, Extended Temperature, 8L-SOIC pkg.</p> <p>a) MCP2004-E/MD: Extended Temperature, 8L-DFN pkg. b) MCP2004-E/P: Extended Temperature, 8L-PDIP pkg. c) MCP2004-E/SN: Extended Temperature, 8L-SOIC pkg. d) MCP2004T-E/MD: Tape and Reel, Extended Temperature, 8L-DFN pkg. e) MCP2004T-E/SN: Tape and Reel, Extended Temperature, 8L-SOIC pkg.</p>

MCP2003/4

NOTES:

Note the following details of the code protection feature on Microchip devices:

- Microchip products meet the specification contained in their particular Microchip Data Sheet.
- Microchip believes that its family of products is one of the most secure families of its kind on the market today, when used in the intended manner and under normal conditions.
- There are dishonest and possibly illegal methods used to breach the code protection feature. All of these methods, to our knowledge, require using the Microchip products in a manner outside the operating specifications contained in Microchip's Data Sheets. Most likely, the person doing so is engaged in theft of intellectual property.
- Microchip is willing to work with the customer who is concerned about the integrity of their code.
- Neither Microchip nor any other semiconductor manufacturer can guarantee the security of their code. Code protection does not mean that we are guaranteeing the product as “unbreakable.”

Code protection is constantly evolving. We at Microchip are committed to continuously improving the code protection features of our products. Attempts to break Microchip's code protection feature may be a violation of the Digital Millennium Copyright Act. If such acts allow unauthorized access to your software or other copyrighted work, you may have a right to sue for relief under that Act.

Information contained in this publication regarding device applications and the like is provided only for your convenience and may be superseded by updates. It is your responsibility to ensure that your application meets with your specifications. MICROCHIP MAKES NO REPRESENTATIONS OR WARRANTIES OF ANY KIND WHETHER EXPRESS OR IMPLIED, WRITTEN OR ORAL, STATUTORY OR OTHERWISE, RELATED TO THE INFORMATION, INCLUDING BUT NOT LIMITED TO ITS CONDITION, QUALITY, PERFORMANCE, MERCHANTABILITY OR FITNESS FOR PURPOSE. Microchip disclaims all liability arising from this information and its use. Use of Microchip devices in life support and/or safety applications is entirely at the buyer's risk, and the buyer agrees to defend, indemnify and hold harmless Microchip from any and all damages, claims, suits, or expenses resulting from such use. No licenses are conveyed, implicitly or otherwise, under any Microchip intellectual property rights.

Trademarks

The Microchip name and logo, the Microchip logo, dsPIC, KEELOQ, KEELOQ logo, MPLAB, PIC, PICmicro, PICSTART, PIC³² logo, rPIC and UNI/O are registered trademarks of Microchip Technology Incorporated in the U.S.A. and other countries.

FilterLab, Hampshire, HI-TECH C, Linear Active Thermistor, MXDEV, MXLAB, SEEVAL and The Embedded Control Solutions Company are registered trademarks of Microchip Technology Incorporated in the U.S.A.

Analog-for-the-Digital Age, Application Maestro, CodeGuard, dsPICDEM, dsPICDEM.net, dsPICworks, dsSPEAK, ECAN, ECONOMONITOR, FanSense, HI-TIDE, In-Circuit Serial Programming, ICSP, Mindi, MiWi, MPASM, MPLAB Certified logo, MPLIB, MPLINK, mTouch, Octopus, Omniscient Code Generation, PICC, PICC-18, PICDEM, PICDEM.net, PICkit, PICTail, REAL ICE, rLAB, Select Mode, Total Endurance, TSHARC, UniWinDriver, WiperLock and ZENA are trademarks of Microchip Technology Incorporated in the U.S.A. and other countries.

SQTP is a service mark of Microchip Technology Incorporated in the U.S.A.

All other trademarks mentioned herein are property of their respective companies.

© 2010, Microchip Technology Incorporated, Printed in the U.S.A., All Rights Reserved.

 Printed on recycled paper.

ISBN: 978-1-60932-080-5

Microchip received ISO/TS-16949:2002 certification for its worldwide headquarters, design and wafer fabrication facilities in Chandler and Tempe, Arizona; Gresham, Oregon and design centers in California and India. The Company's quality system processes and procedures are for its PIC® MCUs and dsPIC® DSCs, KEELOQ® code hopping devices, Serial EEPROMs, microperipherals, nonvolatile memory and analog products. In addition, Microchip's quality system for the design and manufacture of development systems is ISO 9001:2000 certified.

**QUALITY MANAGEMENT SYSTEM
CERTIFIED BY DNV
== ISO/TS 16949:2002 ==**



WORLDWIDE SALES AND SERVICE

AMERICAS

Corporate Office

2355 West Chandler Blvd.
Chandler, AZ 85224-6199
Tel: 480-792-7200
Fax: 480-792-7277
Technical Support:
<http://support.microchip.com>
Web Address:
www.microchip.com

Atlanta

Duluth, GA
Tel: 678-957-9614
Fax: 678-957-1455

Boston

Westborough, MA
Tel: 774-760-0087
Fax: 774-760-0088

Chicago

Itasca, IL
Tel: 630-285-0071
Fax: 630-285-0075

Cleveland

Independence, OH
Tel: 216-447-0464
Fax: 216-447-0643

Dallas

Addison, TX
Tel: 972-818-7423
Fax: 972-818-2924

Detroit

Farmington Hills, MI
Tel: 248-538-2250
Fax: 248-538-2260

Kokomo

Kokomo, IN
Tel: 765-864-8360
Fax: 765-864-8387

Los Angeles

Mission Viejo, CA
Tel: 949-462-9523
Fax: 949-462-9608

Santa Clara

Santa Clara, CA
Tel: 408-961-6444
Fax: 408-961-6445

Toronto

Mississauga, Ontario,
Canada
Tel: 905-673-0699
Fax: 905-673-6509

ASIA/PACIFIC

Asia Pacific Office

Suites 3707-14, 37th Floor
Tower 6, The Gateway
Harbour City, Kowloon
Hong Kong
Tel: 852-2401-1200
Fax: 852-2401-3431

Australia - Sydney

Tel: 61-2-9868-6733
Fax: 61-2-9868-6755

China - Beijing

Tel: 86-10-8528-2100
Fax: 86-10-8528-2104

China - Chengdu

Tel: 86-28-8665-5511
Fax: 86-28-8665-7889

China - Chongqing

Tel: 86-23-8980-9588
Fax: 86-23-8980-9500

China - Hong Kong SAR

Tel: 852-2401-1200
Fax: 852-2401-3431

China - Nanjing

Tel: 86-25-8473-2460
Fax: 86-25-8473-2470

China - Qingdao

Tel: 86-532-8502-7355
Fax: 86-532-8502-7205

China - Shanghai

Tel: 86-21-5407-5533
Fax: 86-21-5407-5066

China - Shenyang

Tel: 86-24-2334-2829
Fax: 86-24-2334-2393

China - Shenzhen

Tel: 86-755-8203-2660
Fax: 86-755-8203-1760

China - Wuhan

Tel: 86-27-5980-5300
Fax: 86-27-5980-5118

China - Xian

Tel: 86-29-8833-7252
Fax: 86-29-8833-7256

China - Xiamen

Tel: 86-592-2388138
Fax: 86-592-2388130

China - Zhuhai

Tel: 86-756-3210040
Fax: 86-756-3210049

ASIA/PACIFIC

India - Bangalore

Tel: 91-80-3090-4444
Fax: 91-80-3090-4123

India - New Delhi

Tel: 91-11-4160-8631
Fax: 91-11-4160-8632

India - Pune

Tel: 91-20-2566-1512
Fax: 91-20-2566-1513

Japan - Yokohama

Tel: 81-45-471- 6166
Fax: 81-45-471-6122

Korea - Daegu

Tel: 82-53-744-4301
Fax: 82-53-744-4302

Korea - Seoul

Tel: 82-2-554-7200
Fax: 82-2-558-5932 or
82-2-558-5934

Malaysia - Kuala Lumpur

Tel: 60-3-6201-9857
Fax: 60-3-6201-9859

Malaysia - Penang

Tel: 60-4-227-8870
Fax: 60-4-227-4068

Philippines - Manila

Tel: 63-2-634-9065
Fax: 63-2-634-9069

Singapore

Tel: 65-6334-8870
Fax: 65-6334-8850

Taiwan - Hsin Chu

Tel: 886-3-6578-300
Fax: 886-3-6578-370

Taiwan - Kaohsiung

Tel: 886-7-536-4818
Fax: 886-7-536-4803

Taiwan - Taipei

Tel: 886-2-2500-6610
Fax: 886-2-2508-0102

Thailand - Bangkok

Tel: 66-2-694-1351
Fax: 66-2-694-1350

EUROPE

Austria - Wels

Tel: 43-7242-2244-39
Fax: 43-7242-2244-393

Denmark - Copenhagen

Tel: 45-4450-2828
Fax: 45-4485-2829

France - Paris

Tel: 33-1-69-53-63-20
Fax: 33-1-69-30-90-79

Germany - Munich

Tel: 49-89-627-144-0
Fax: 49-89-627-144-44

Italy - Milan

Tel: 39-0331-742611
Fax: 39-0331-466781

Netherlands - Drunen

Tel: 31-416-690399
Fax: 31-416-690340

Spain - Madrid

Tel: 34-91-708-08-90
Fax: 34-91-708-08-91

UK - Wokingham

Tel: 44-118-921-5869
Fax: 44-118-921-5820

01/05/10

Mouser Electronics

Authorized Distributor

Click to View Pricing, Inventory, Delivery & Lifecycle Information:

Microchip:

[MCP2003-E/MD](#) [MCP2003-E/P](#) [MCP2003-E/SN](#) [MCP2003T-E/MD](#) [MCP2003T-E/SN](#) [MCP2004-E/MD](#) [MCP2004-E/P](#) [MCP2004-E/SN](#) [MCP2004T-E/MD](#) [MCP2004T-E/SN](#) [MCP2003B-H/SN](#) [MCP2003B-E/MF](#) [MCP2003B-H/MF](#) [MCP2003BT-H/SN](#) [MCP2003B-H/MC](#) [MCP2003BT-E/MF](#) [MCP2003BT-E/MC](#) [MCP2003B-E/SN](#) [MCP2003BT-E/SN](#) [MCP2003BT-H/MF](#) [MCP2003B-E/MC](#) [MCP2003BT-H/MC](#)