

## L9217A/G Low-Cost Line Interface with Reverse Battery and PPM

### Features

- Basic forward/reverse battery SLIC functionality at a low cost
- Pin compatible with Agere Systems Inc. L9218/L9219 SLIC
- Low active power (typical 154 mW during on-hook transmission)
- Low-power scan mode for low-power, on-hook power dissipation (57 mW typical)
- Distortion-free, on-hook transmission
- Convenient operating states:
  - Forward powerup
  - Reverse powerup
  - Low-power scan
  - Disconnect (high impedance)
  - PPM operational states
- Minimal external components required
- Two gain options to optimize the codec interface
- Adjustable supervision functions:
  - Off-hook detector with hysteresis
  - Ring trip detector
- Adjustable loop current limit
- Adjustable overhead voltage
- Ramped rate of battery reversal
- Periodic pulse metering (PPM) compatible
- Thermal protection with thermal shutdown indication

### Description

This general-purpose electronic subscriber loop interface circuit (SLIC) is optimized for low cost, while still providing a satisfactory set of features. This part is a pin-for-pin replacement for the Agere L9218/L9219 SLIC.

The L9217 requires a 5 V power supply and single battery to operate. This device offers forward and reverse battery operation. The rate of battery reversal may be ramped to meet international requirements. Additionally, a low-power scan mode, wherein all circuitry except the off-hook supervision is shut down to conserve power, is available.

The dc current limit may be programmed via a single external resistor. Both the loop supervision and ring trip supervision functions are offered with user-controlled thresholds via external resistors. Overhead is adequate for 3.14 dBm into 900  $\Omega$  of on-hook transmission.

The device is periodic pulse metering (PPM) compatible, offering a convenient point for meter pulse injection and filter point for rejection of the meter pulse signal. In the PPM active modes, overhead voltage is automatically increased to accommodate on-hook transmission of meter pulse signals. The level that the overhead is increased to is set by a single external resistor. In this way, the L9217 can accommodate high-voltage meter pulse signals.

The L9217 is offered with a receive gain that is optimized to interface to a first-generation type codec (L9217A). It is also offered with a gain option that is optimized to interface to a third- or fourth-generation type codec (L9217G). In both cases, minimizing external components is required at this interface.

Data control is via a parallel data control scheme.

The device is available in a 28-pin PLCC package. It is built by using a 90 V complementary bipolar (CBIC) process.

**Table of Contents**

<b>Contents</b>	<b>Page</b>	<b>Figures</b>	<b>Page</b>
Features .....	1	Figure 13. Loop Current vs. Loop Voltage .....	19
Description.....	1	Figure 14. Off-Hook Detection Circuit .....	20
Pin Information .....	4	Figure 15. Ring Trip Equivalent Circuit and Equivalent Application .....	21
Functional Description .....	6	Figure 16. ac Equivalent Circuit .....	24
Absolute Maximum Ratings (at TA = 25 °C) .....	7	Figure 17. Interface Circuit Using First- Generation Codec (±5 V Codec) .....	27
Recommended Operating Conditions .....	7	Figure 18. Interface Circuit Using First- Generation Codec (5 V Only Codec) .....	27
Electrical Characteristics .....	8		
Ring Trip Requirements .....	12		
Test Configurations .....	13		
Applications .....	15		
dc Applications.....	19		
Battery Feed.....	19		
Overhead Voltage .....	19		
Rate of Battery Reversal .....	20		
Loop Range.....	20		
Off-Hook Detection.....	20		
Ring Trip Detection.....	21		
Longitudinal Balance.....	21		
Periodic Pulse Metering (PPM).....	22		
ac Design .....	23		
Codec Types .....	23		
ac Interface Network .....	23		
Receive Interface .....	23		
Example 1: Real Termination (First- Generation Codec).....	24		
Example 2: Complex Termination (First- Generation Codec).....	26		
Power Derating .....	28		
Pin-for-Pin Compatibility with L9218/L9219 .....	28		
PCB Layout Information .....	28		
Outline Diagram.....	29		
28-Pin PLCC .....	29		
Ordering Information.....	30		
		<b>Tables</b>	<b>Page</b>
		Table 1. Pin Descriptions .....	4
		Table 2. Input State Coding .....	6
		Table 3. Supervision Coding .....	6
		Table 4. Power Supply .....	8
		Table 5. 2-Wire Port .....	9
		Table 6. Analog Pin Characteristics .....	10
		Table 7. PPM .....	10
		Table 8. ac Feed Characteristics .....	11
		Table 9. Logic Inputs and Outputs .....	12
		Table 10. Parts List for Loop Start Application Circuit Using T7504-Type Codec .....	16
		Table 11. 900 W Termination, 850 W + 50 nF Hybrid First-Generation Codec Design Parameters .....	17
		Table 12. Parts List for Loop Start Application Circuit Using T8536-Type Codec .....	18
		Table 13. FB1/FB2 Values vs. Typical Ramp Time .....	20
<b>Figures</b>	<b>Page</b>		
Figure 1. Functional Diagram.....	3		
Figure 2. 28-Pin PLCC.....	4		
Figure 3. Ring Trip Circuits .....	12		
Figure 4. L9217 Basic Test Circuit.....	13		
Figure 5. Metallic PSRR.....	13		
Figure 6. Longitudinal PSRR .....	13		
Figure 7. Longitudinal Balance .....	14		
Figure 8. RFI Rejection .....	14		
Figure 9. Longitudinal Impedance.....	14		
Figure 10. ac Gains.....	14		
Figure 11. Basic Loop Start Application Circuit Using T7504-Type Codec.....	15		
Figure 12. Basic Loop Start Application Circuit Using T8536-Type Codec.....	17		

Description (continued)

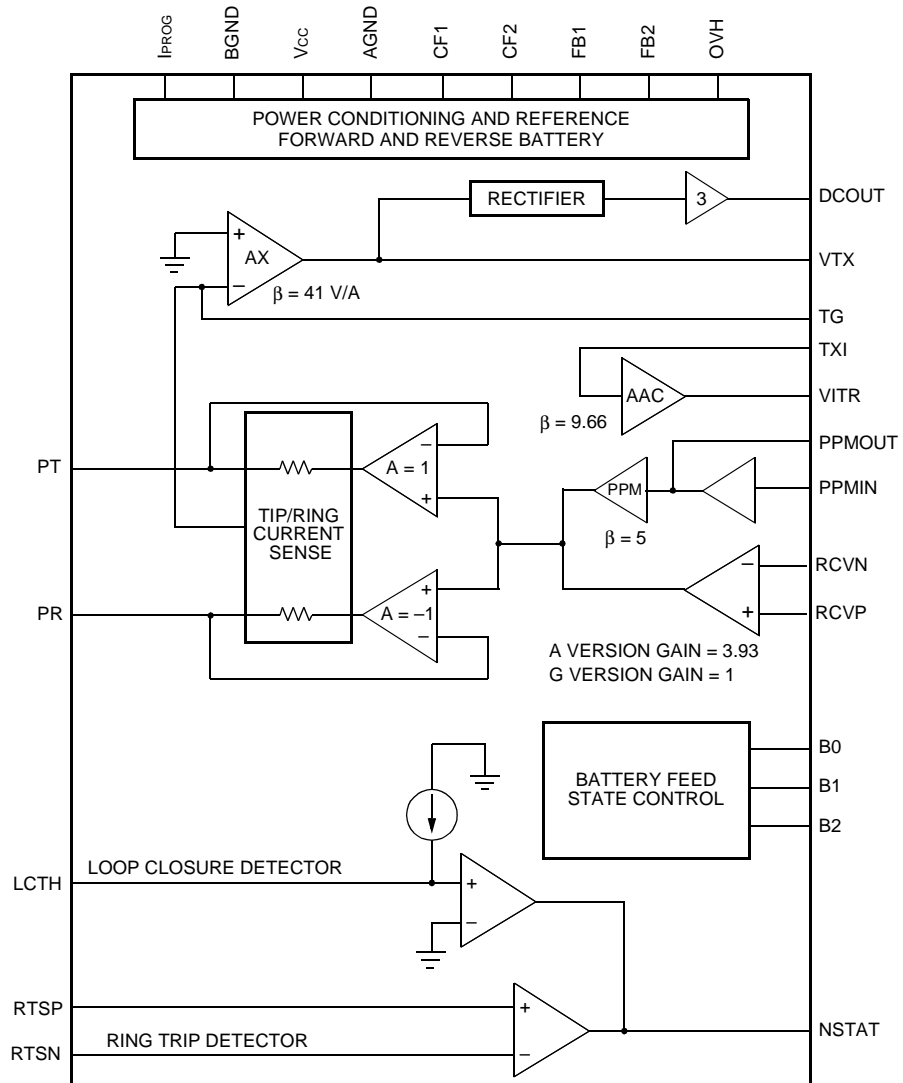

12-3557 (F)

Figure 1. Functional Diagram

## Pin Information

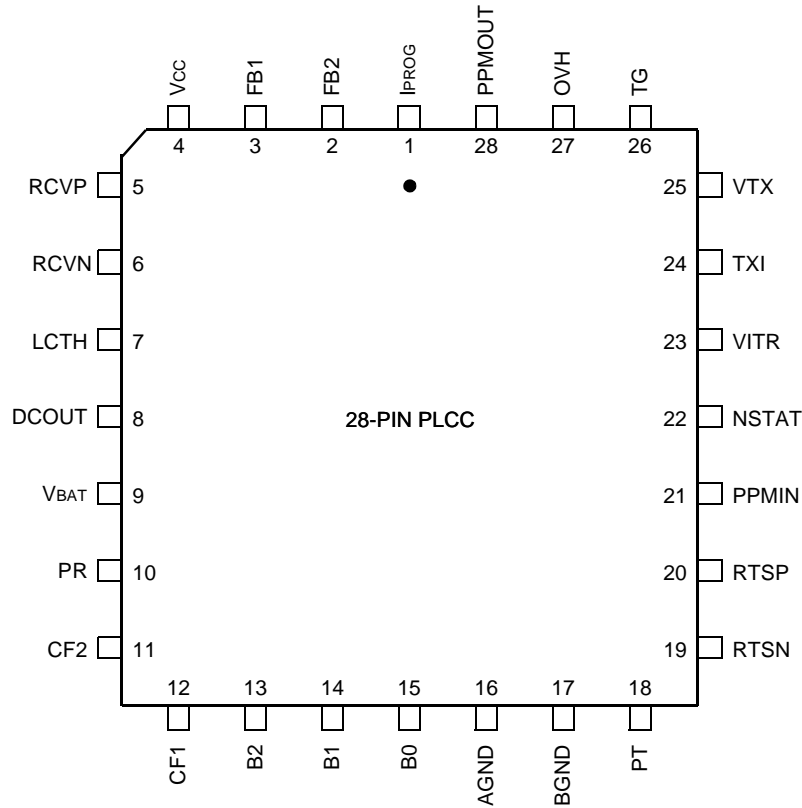

12-3558 (F).c

Figure 2. 28-Pin PLCC

Table 1. Pin Descriptions

PLCC	Symbol	Type	Description
1	I <sub>PROG</sub>	I	<b>Current-Limit Program Input.</b> A resistor to DCOUT sets the dc current limit of the device.
2	FB2	—	<b>Polarity Reversal Slowdown.</b> Connect a capacitor to ground to control the rate of battery reversal.
3	FB1	—	<b>Polarity Reversal Slowdown.</b> Connect a capacitor to ground to control the rate of battery reversal.
4	V <sub>CC</sub>	—	<b>5 V Power Supply.</b>
5	RCVP	I	<b>Receive ac Signal Input (Noninverting).</b> This high-impedance input controls the ac differential voltage on tip and ring.
6	RCVN	I	<b>Receive ac Signal Input (Inverting).</b> This high-impedance input controls the ac differential voltage on tip and ring.

Pin Information (continued)

Table 1. Pin Descriptions (continued)

PLCC	Symbol	Type	Description
7	LCTH	I	<b>Loop Closure Threshold Input.</b> Connect a resistor to DCOUT to set off-hook threshold.
8	DCOUT	O	<b>dc Output Voltage.</b> This output is a voltage that is directly proportional to the absolute value of the differential tip/ring current.
9	VBAT	—	<b>Battery Supply.</b> Negative high-voltage power supply.
10	PR	I/O	<b>Protected Ring.</b> The output of the ring driver amplifier and input to loop sensing circuitry. Connect to the loop through overvoltage protection.
11	CF2	—	<b>Filter Capacitor 2.</b> Connect a 0.1 $\mu$ F capacitor from this pin to AGND.
12	CF1	—	<b>Filter Capacitor 1.</b> Connect a 0.47 $\mu$ F capacitor from this pin to pin CF2.
13	B2	I	<b>State Control Input.</b> B0, B1, and B2 determine the state of the SLIC. See Table 2. Pin B2 has internal pull-down.
14	B1	I	<b>State Control Input.</b> B0, B1, and B2 determine the state of the SLIC. See Table 2. Pin B1 has internal pull-down.
15	B0	I	<b>State Control Input.</b> B0, B1, and B2 determine the state of the SLIC. See Table 2. Pin B0 has internal pull-down.
16	AGND	—	Analog Signal Ground.
17	BGND	—	<b>Battery Ground.</b> Ground return for the battery supply.
18	PT	I/O	<b>Protected Tip.</b> The output of the tip driver amplifier and input to loop sensing circuitry. Connect to loop through overvoltage protection.
19	RTSN	I	<b>Ring Trip Sense Negative.</b> Connect this pin to the ringing generator signal through a high-value resistor.
20	RTSP	I	<b>Ring Trip Sense Positive.</b> Connect this pin to the ring relay and the ringer series resistor through a high-value resistor.
21	PPMIN	I	<b>Receive PPM Signal Input.</b> This high-impedance input controls the PPM differential voltage on tip and ring. The PPM signal may be present at this pin at all times: however, PPM will only be transmitted to tip and ring if the appropriate PPM state is chosen. ac couple the PPM signal to this node.
22	NSTAT	O	<b>Ring Trip Detector Output/Loop Detector Output.</b> When low, this logic output indicates that ringing is tripped or that an off-hook condition exists.
23	VITR	O	<b>ac Output Voltage.</b> The voltage at this point is directly proportional to the differential tip/ring current.
24	TXI	I	<b>ac/dc Separation.</b> Connect a 0.1 $\mu$ F capacitor from this point to VTX.
25	VTX	O	<b>ac Output Voltage.</b> This output is a voltage that is directly proportional to the differential tip/ring current.
26	TG	—	<b>Transmit Gain.</b> Connect an 8.06 k $\Omega$ from TG to VTX to set the transmit gain of the SLIC.
27	OVH	I	<b>PPM Overhead.</b> Connect a resistor from this node to ground to set the overhead voltage during PPM high overhead modes.
28	PPMOUT	O	<b>PPM Signal Output.</b> Connect a resistor from this node to TG for hybrid cancellation of the periodic pulse metering (PPM) signal.

## Functional Description

Table 2. Input State Coding

B0	B1	B2	State/Definition
1	1	1	<b>Powerup, Forward Battery, Normal Overhead.</b> Normal talk and battery feed state. Pin PT is positive with respect to PR. On-hook transmission is enabled. PPM is not active. Overhead is unaffected by resistor OVH and is adequate for 3.14 dBm overload into 900 $\Omega$ .
1	0	1	<b>Powerup, Reverse Battery, Normal Overhead.</b> Normal talk and battery feed state. Pin PT is negative with respect to PR. On-hook transmission is enabled. PPM is not active. Overhead is unaffected by resistor OVH and is adequate for 3.14 dBm overload into 900 $\Omega$ .
1	1	0	<b>Powerup, Forward Battery, High Overhead.</b> Normal talk and battery feed state. Pin PT is positive with respect to PR. On-hook transmission is enabled. PPM is not active. Overhead is increased via resistor OVH.
1	0	0	<b>Powerup, Reverse Battery, High Overhead.</b> Normal talk and battery feed state. Pin PT is negative with respect to PR. On-hook transmission is enabled. PPM is not active. Overhead is increased via resistor OVH.
0	1	1	<b>Low-Power Scan.</b> Except for off-hook detection, all circuits are shut down to conserve power. Pin PT is positive with respect to pin PR. On-hook transmission is disabled.
0	0	1	<b>Disconnect.</b> The tip and ring amplifiers are turned off, and the SLIC goes to a high-impedance state (>100 k $\Omega$ ). Supervision outputs read on hook. Device will power up in this state.
0	0	0	<b>Powerup, Reverse Battery, High Overhead with PPM.</b> Normal talk and battery feed state. Pin PT is negative with respect to PR. On-hook transmission is enabled. PPM is active. Overhead is increased via resistor OVH.
0	1	0	<b>Powerup, Forward Battery, High Overhead with PPM.</b> Normal talk and battery feed state. Pin PT is positive with respect to PR. On-hook transmission is enabled. PPM is active. Overhead is increased via resistor OVH.

Table 3. Supervision Coding

NSTAT
0 = off-hook or ring trip. 1 = on-hook and no ring trip.

### Absolute Maximum Ratings (at T<sub>A</sub> = 25 °C)

Stresses in excess of the absolute maximum ratings can cause permanent damage to the device. These are absolute stress ratings only. Functional operation of the device is not implied at these or any other conditions in excess of those given in the operational sections of the data sheet. Exposure to absolute maximum ratings for extended periods can adversely affect device reliability.

Parameter	Symbol	Min	Typ	Max	Unit
5 V Power Supply	V <sub>CC</sub>	—	—	7.0	V
Battery (Talking) Supply	V <sub>BAT</sub>	—	—	-75	V
Logic Input Voltage	—	-0.5	—	7.0	V
Analog Input Voltage	—	-7.0	—	7.0	V
Maximum Junction Temperature	T <sub>J</sub>	150	—	—	°C
Storage Temperature Range	T <sub>stg</sub>	-40	—	125	°C
Relative Humidity Range	RH	5	—	95	%
Ground Potential Difference (BGND to AGND)	—	—	±3	—	V
PT or PR Fault Voltage (dc)	V <sub>PT</sub> , V <sub>PR</sub>	V <sub>BAT</sub> - 5	—	3	V
PT or PR Fault Voltage (10 x 1000 μs)	V <sub>PT</sub> , V <sub>PR</sub>	V <sub>BAT</sub> - 15	—	15	V
Current into Ring Trip Inputs	I <sub>RTSP</sub> , I <sub>RTSN</sub>	—	±240	—	μA

Note: The IC can be damaged unless all ground connections are applied before, and removed after, all other connections. Furthermore, when powering the device, the user must guarantee that no external potential creates a voltage on any pin of the device that exceeds the device ratings. Some of the known examples of conditions that cause such potentials during powerup are the following:

1. An inductor connected to tip and ring can force an overvoltage on V<sub>BAT</sub> through the protection devices if the V<sub>BAT</sub> connection chatters.
2. Inductance in the V<sub>BAT</sub> lead could resonate with the V<sub>BAT</sub> filter capacitor to cause a destructive overvoltage.

### Recommended Operating Conditions

Parameter	Min	Typ	Max	Unit
Ambient Temperature	-40	—	85	°C
V <sub>CC</sub> Supply Voltage	4.75	5.0	5.25	V
V <sub>BAT</sub> Supply Voltage	-24	-48	-70	V

## Electrical Characteristics

Minimum and maximum values are testing requirements in the temperature range of 25 °C to 85 °C and battery range of –24 V to –70 V. These minimum and maximum values are guaranteed to –40 °C based on component simulations and design verification of samples, but devices are not tested to –40 °C in production. The test circuit shown in Figure 4 is used, unless otherwise noted. Positive currents flow into the device.

Typical values are characteristics of the device design at 25 °C based on engineering evaluations and are not part of the test requirements. Supply values used for typical characterization are  $V_{CC} = 5.0$  V,  $V_{BAT} = -48$  V, unless otherwise noted.

**Table 4. Power Supply**

Parameter	Min	Typ	Max	Unit
Power Supply—Powerup, No Loop Current:				
$I_{CC}$	—	5.2	6.5	mA
$I_{BAT}$ ( $V_{BAT} = -48$ V)	—	-2.66	-2.95	mA
Power Dissipation ( $V_{BAT} = -48$ V)	—	154	175	mW
Power Supply—Scan, No Loop Current:				
$I_{CC}$	—	3.4	4.3	mA
$I_{BAT}$ ( $V_{BAT} = -48$ V)	—	-0.9	-1	mA
Power Dissipation ( $V_{BAT} = -48$ V)	—	57	70	mW
Power Supply—Disconnect, No Loop Current:				
$I_{CC}$	—	1.9	—	mA
$I_{BAT}$ ( $V_{BAT} = -48$ V)	—	-0.1	—	mA
Power Dissipation ( $V_{BAT} = -48$ V)	—	14	—	mW
Power Supply Rejection 500 Hz to 3 kHz (See Figures 5, 6, 16, and 17.) <sup>1</sup> :				
$V_{CC}$	30	—	—	dB
$V_{BAT}$	36	—	—	dB
Thermal Protection Shutdown ( $T_{jc}$ ) <sup>1</sup>	150	165	—	°C
Thermal Resistance Still Air, Junction to Ambient ( $\theta_{JA}$ ) <sup>1, 2</sup> :				
Natural Convection 2S2P Board	—	30	—	°C/W
Natural Convection 2S0P Board	—	43	—	°C/W
Wind Tunnel 100 Linear Feet per Minute (LFPM) 2S2P Board	—	27	—	°C/W
Wind Tunnel 100 Linear Feet per Minute (LFPM) 2S0P Board	—	36	—	°C/W

1. This parameter is not tested in production. It is guaranteed by design and device characterization.

2. Airflow, PCB board layers, and other factors can greatly affect this parameter.



Electrical Characteristics (continued)

Table 5. 2-Wire Port

Parameter	Min	Typ	Max	Unit
Tip or Ring Drive Current = dc + Longitudinal + Signal Currents	80	—	—	mA
Signal Current	15	—	—	mArms
Longitudinal Current Capability per Wire <sup>1</sup>	8.5	15	—	mArms
dc Loop Current Limit <sup>2</sup> : Allowed Range Including Tolerance <sup>3</sup> Accuracy ( $R_{LOOP} = 100 \Omega$ , $V_{BAT} = -48 V$ )	15 —	— $\pm 5$	45 —	mA %
Powerup Open Loop Voltage Levels (PPMOFF): Common-mode Voltage Differential Voltage $V_{BAT} = -48 V^4$ (Gain = 2) Differential Voltage $V_{BAT} = -48 V^4$ (Gain = 7.86)	— $ V_{BAT} + 7.5 $ $ V_{BAT} + 8.0 $	$V_{BAT}/2$ $ V_{BAT} + 6.5 $ $ V_{BAT} + 6.5 $	— $ V_{BAT} + 5.9 $ $ V_{BAT} + 5.9 $	V V V
Powerup Open Loop Voltage Levels (PPMON) Minimum Programmed Overhead: Differential Voltage $V_{BAT} = -48 V$ (Gain = 7.86)	—	—	$ V_{BAT} + 18.67 $	V
Disconnect State: Leakage	—	10	150	$\mu A$
dc Feed Resistance (for $I_{LOOP}$ below regulation level) (does not include protection resistor)	—	72	100	$\Omega$
Loop Resistance Range ( $-3.17$ dBm overload into 900 $\Omega$ ; not including protection): $I_{LOOP} = 20$ mA at $V_{BAT} = -48 V$	1800	—	—	$\Omega$
Longitudinal to Metallic Balance— <i>IEEE</i> <sup>®</sup> Std. 455 (See Figure 7.) <sup>5</sup> : 200 Hz to 3400 Hz	58	61	—	dB
Metallic to Longitudinal Balance (open loop): 200 Hz to 4 kHz	40	—	—	dB
RFI Rejection (See Figure 8.) <sup>3</sup> , 0.5 Vrms, 50 $\Omega$ Source, 30% AM Mod 1 kHz: 500 kHz to 100 MHz	— —	— $-55$	— $-45$	— dBV

1. The longitudinal current is independent of dc loop current.
2. Current-limit  $I_{LM}$  is programmed by a resistor,  $R_{PROG}$ , from pin  $I_{PROG}$  to  $DCOUT$ .  $I_{LM}$  is specified at the loop resistance where current limiting begins (see Figure 13).
3. This parameter is not tested in production. It is guaranteed by design and device characterization.
4. Specification is reduced to  $|V_{BAT1} + 10.5 V|$  minimum when  $V_{BAT1} = -70 V$  at 85 °C.
5. Longitudinal balance of circuit card will depend on loop series protection resistor matching and magnitude. More information is available in the Applications section of this document.

**Electrical Characteristics** (continued)

**Table 6. Analog Pin Characteristics**

Parameter	Min	Typ	Max	Unit
Differential PT/PR Current Sense (DCOUT): Gain (PT/PR to DCOUT) Offset Voltage at I <sub>LOOP</sub> = 0	121 -100	125 —	129 100	V/A mV
Loop Closure Detector Threshold (R <sub>LCTH</sub> = 22.1 kΩ) <sup>1</sup> : On- to Off-hook Threshold (scan mode) Off- to On-hook Threshold (active mode)	8.8 6.0	— —	13.6 10.2	mA mA
Ring Trip Comparator: Input Offset Voltage <sup>2</sup> Internal Voltage Source Current at Input RTSP <sup>3</sup>	— -9.1 I <sub>N</sub> - 0.5	±10 -8.6 I <sub>N</sub>	— -8.1 I <sub>N</sub> + 0.5	mV V μA
RCVN, RCVP: Input Bias Current Input Resistance	— —	-0.2 1	-1 —	μA MΩ

1. Loop closure threshold is programmed by resistor R<sub>LCTH</sub> from pin LCTH to pin DCOUT. The programming equation or relationship between off-hook threshold and resistor value is different for active mode versus scan mode (see Applications section for more details).
2. This parameter is not tested in production. It is guaranteed by design and device characterization.
3. I<sub>N</sub> is the sourcing current at RTSN. Guaranteed if I<sub>N</sub> is within 5 μA to 30 μA.

**Table 7. PPM**

Parameter	Min	Typ	Max	Unit
PPM Source*: Frequency (f1) Frequency (f2) Input Signal	11.88 15.80 0	12 16 —	12.12 16.20 0.525	kHz kHz V <sub>rms</sub>
Signal Gain (from PPMIN to amplifier outputs)	9	10	11	—
Harmonic Distortion	—	5	—	%
Isolation	50	—	—	dB

\* PPM signal should be ac-coupled into PPMIN.

**Electrical Characteristics** (continued)

**Table 8. ac Feed Characteristics**

Parameter	Min	Typ	Max	Unit
ac Termination Impedance <sup>1</sup>	150	—	1300	Ω
Longitudinal Impedance at PT/PR <sup>2</sup>	—	0	—	Ω
Total Harmonic Distortion—200 Hz to 4 kHz <sup>2</sup> :				
Off-hook	—	—	0.3	%
On-hook	—	—	1.0	%
Transmit Gain, f = 1 kHz (PT/PR to VITR) (current limit)	-391	-403	-415	V/A
L9217A, Open Loop:				
Receive + Gain, f = 1 kHz (RCVP to PT/PR) <sup>3</sup>	7.62	7.86	8.09	—
Receive - Gain, f = 1 kHz (RCVN to PT/PR) <sup>3</sup>	-7.62	-7.86	-8.09	—
L9217G, Open Loop:				
Receive + Gain, f = 1 kHz (RCVP to PT/PR) <sup>4</sup>	1.94	2.00	2.06	—
Receive - Gain, f = 1 kHz (RCVN to PT/PR) <sup>4</sup>	-1.94	-2.00	-2.06	—
Gain vs. Frequency (transmit and receive) (600 Ω termination; reference 1 kHz <sup>2</sup> ):				
200 Hz to 300 Hz	-1.00	0.0	0.05	dB
300 Hz to 3.4 kHz	-0.3	0.0	0.05	dB
3.4 kHz to 16 kHz	-3.0	-0.1	0.3	dB
16 kHz to 266 kHz	—	—	2.5	dB
Gain vs. Level (transmit and receive)(reference 0 dBV <sup>2</sup> ): -55 dB to +3 dB	-0.05	0	0.05	dB
2-Wire Idle-channel Noise (600 Ω termination):				
Psophometric <sup>2</sup>	—	-87	-77	dBmp
C-message	—	2	12	dBmC
3 kHz Flat <sup>2</sup>	—	10	20	dBm
Transmit Idle-channel Noise:				
Psophometric <sup>2</sup>	—	-82	-77	dBmp
C-message	—	7	12	dBmC
3 kHz Flat <sup>2</sup>	—	15	20	dBm

1. With a first-generation codec, this parameter is set by external components. Any complex impedance  $R1 + R2 \parallel C$  between 150 Ω and 1300 Ω can be synthesized. With a third-generation codec, this parameter is set by a codec or by a combination of a codec and an external network.
2. This parameter is not tested in production. It is guaranteed by design and device characterization.
3. Use this gain option with an Agere first-generation or third-generation codec.
4. Use this gain option with an Agere third-generation codec.

**Electrical Characteristics** (continued)

**Table 9. Logic Inputs and Outputs**

All outputs are open collectors with internal, 30 kΩ pull-up resistor. Input pins have internal pull-down or some method to power up in the disconnect state.

Parameter	Symbol	Min	Typ	Max	Unit
Input Voltages:					
Low Level (permissible range)	$V_{IL}$	-0.5	0.4	0.7	V
High Level (permissible range)	$V_{IH}$	2.0	2.4	$V_{CC}$	V
Input Currents:					
Low Level ( $V_{CC} = 5.25$ V, $V_I = 0.4$ V)	$I_{IL}$	0	4	10	μA
High Level ( $V_{CC} = 5.25$ V, $V_I = 2.4$ V)	$I_{IH}$	10	24	50	μA
Output Voltages (open collector with internal pull-up resistor):					
Low Level ( $V_{CC} = 4.75$ V, $I_{OL} = 200$ μA)	$V_{OL}$	0	0.2	0.4	V
High Level ( $V_{CC} = 4.75$ V, $I_{OH} = -20$ μA)	$V_{OH}$	2.4	—	$V_{CC}$	V

**Ring Trip Requirements**

- Ringing signal:
  - Voltage, minimum 35 Vrms, maximum 100 Vrms.
  - Frequency, 17 Hz to 33 Hz.
  - Crest factor, 1.2 to 1.6.
- Ring trip:
  - ≤100 ms (typical).
- Pretrip:
  - The circuits in Figure 3 will not cause ring trip.

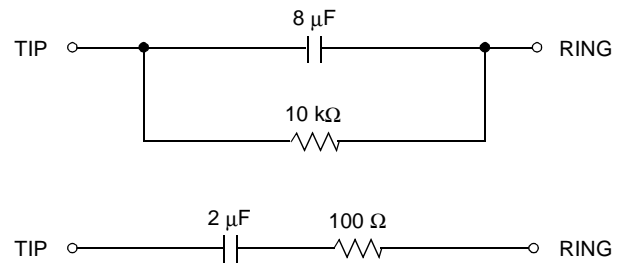

12-2572 (F).f

**Figure 3. Ring Trip Circuits**

### Test Configurations

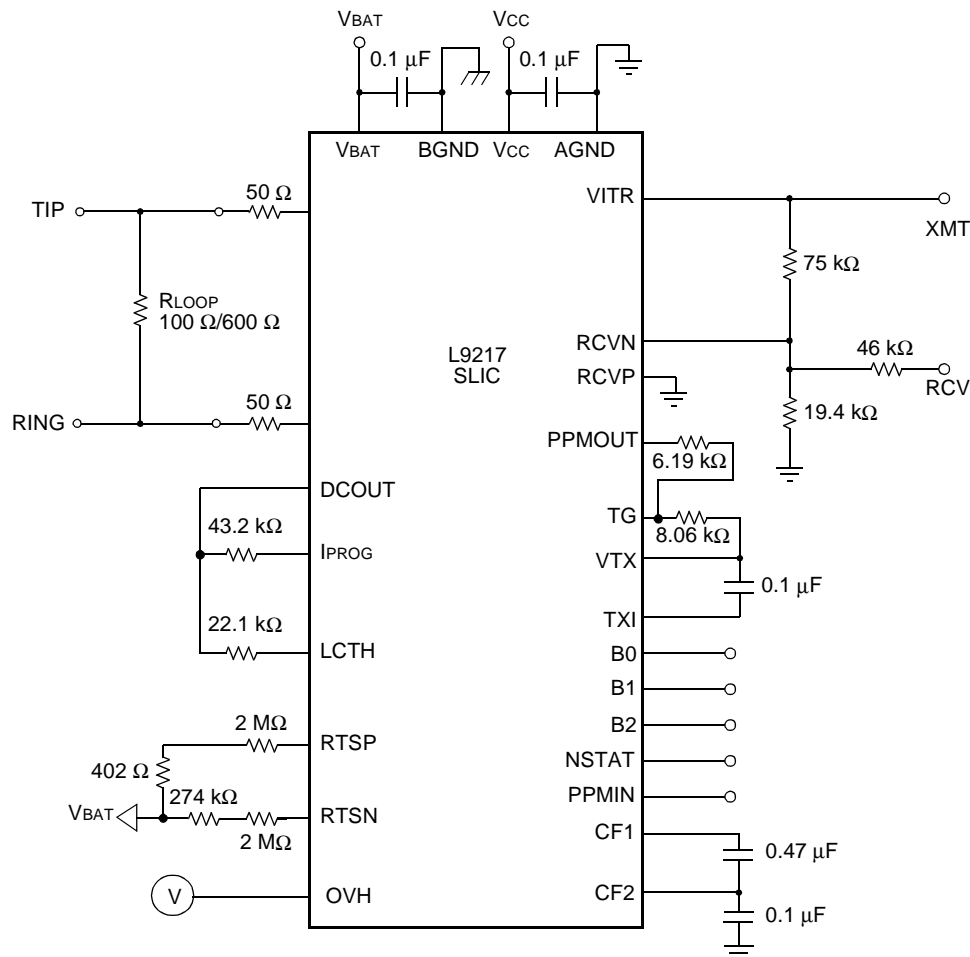

12-3559 (F).Em

Figure 4. L9217 Basic Test Circuit

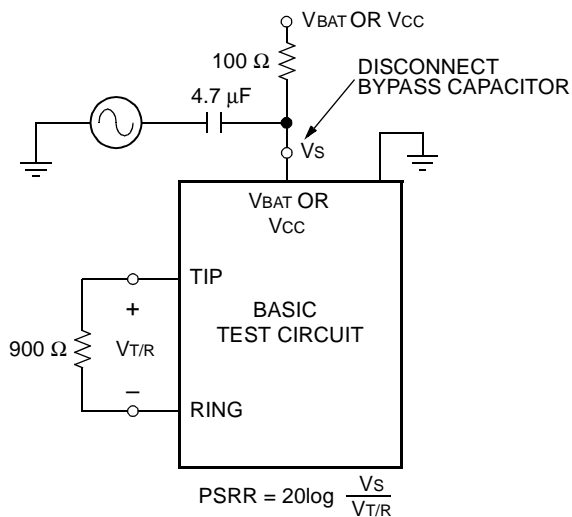

12-2582 (F).b

Figure 5. Metallic PSRR

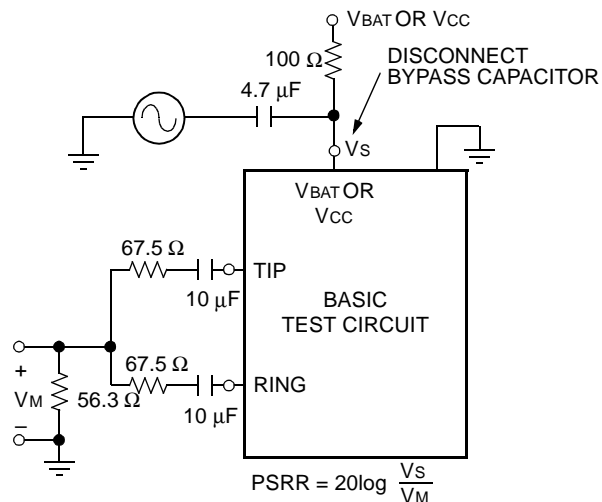

12-2583 (F).b

Figure 6. Longitudinal PSRR

Test Configurations (continued)

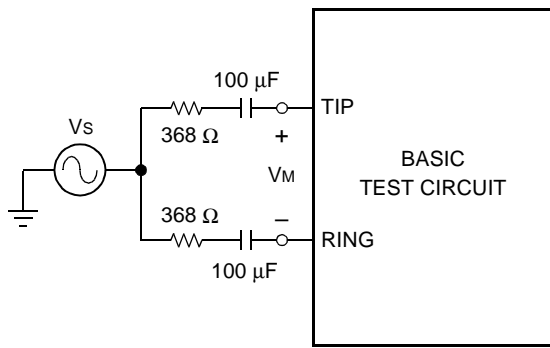

$$\text{LONGITUDINAL BALANCE} = 20 \log \frac{V_s}{V_M}$$

12-2584 (F).c

Figure 7. Longitudinal Balance

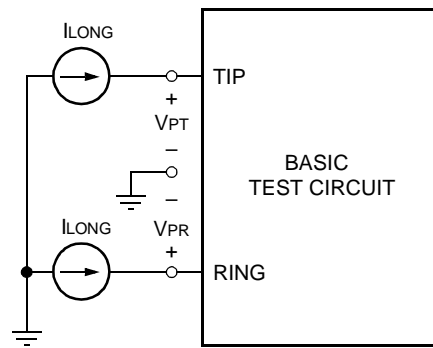

$$Z_{\text{LONG}} = \frac{\Delta V_{PT}}{\Delta I_{\text{LONG}}} \text{ OR } \frac{\Delta V_{PR}}{\Delta I_{\text{LONG}}}$$

12-2585 (F).a

Figure 9. Longitudinal Impedance

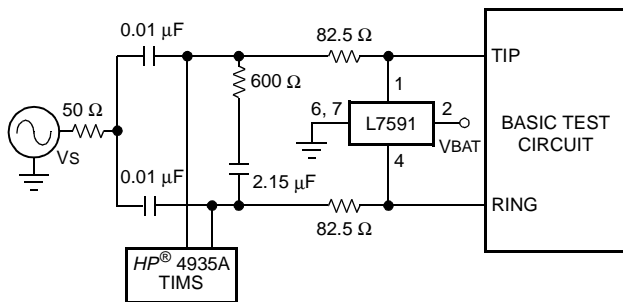

5-6756 (F).bm

$V_s = 0.5 \text{ V}_{\text{rms}}$  30% AM 1 kHz modulation,  
 $f = 500 \text{ kHz} - 1 \text{ MHz}$   
device in powerup mode, 600  $\Omega$  termination.

Figure 8. RFI Rejection

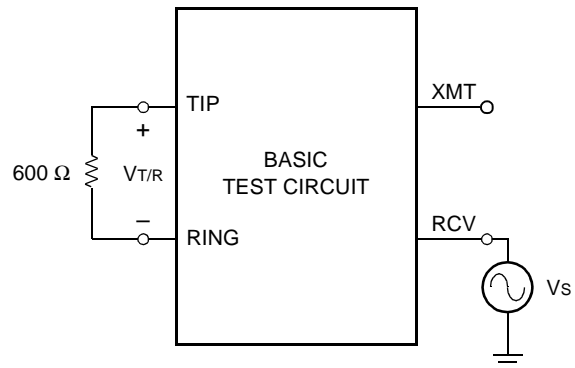

$$G_{\text{XMT}} = \frac{V_{\text{XMT}}}{V_{\text{T/R}}}$$

$$G_{\text{RCV}} = \frac{V_{\text{T/R}}}{V_{\text{RCV}}}$$

12-2587 (F).e

Figure 10. ac Gains

## Applications

A basic loop start reference circuit, using based ringing with the L9217 SLIC and the T7504 first-generation codec, is shown in Figure 11. This circuit is designed for a 900  $\Omega$  termination impedance and an 850  $\Omega$  + 50 nF transhybrid. Transmit gain is set at 0 dBm and receive gain is set at -7 dBm.

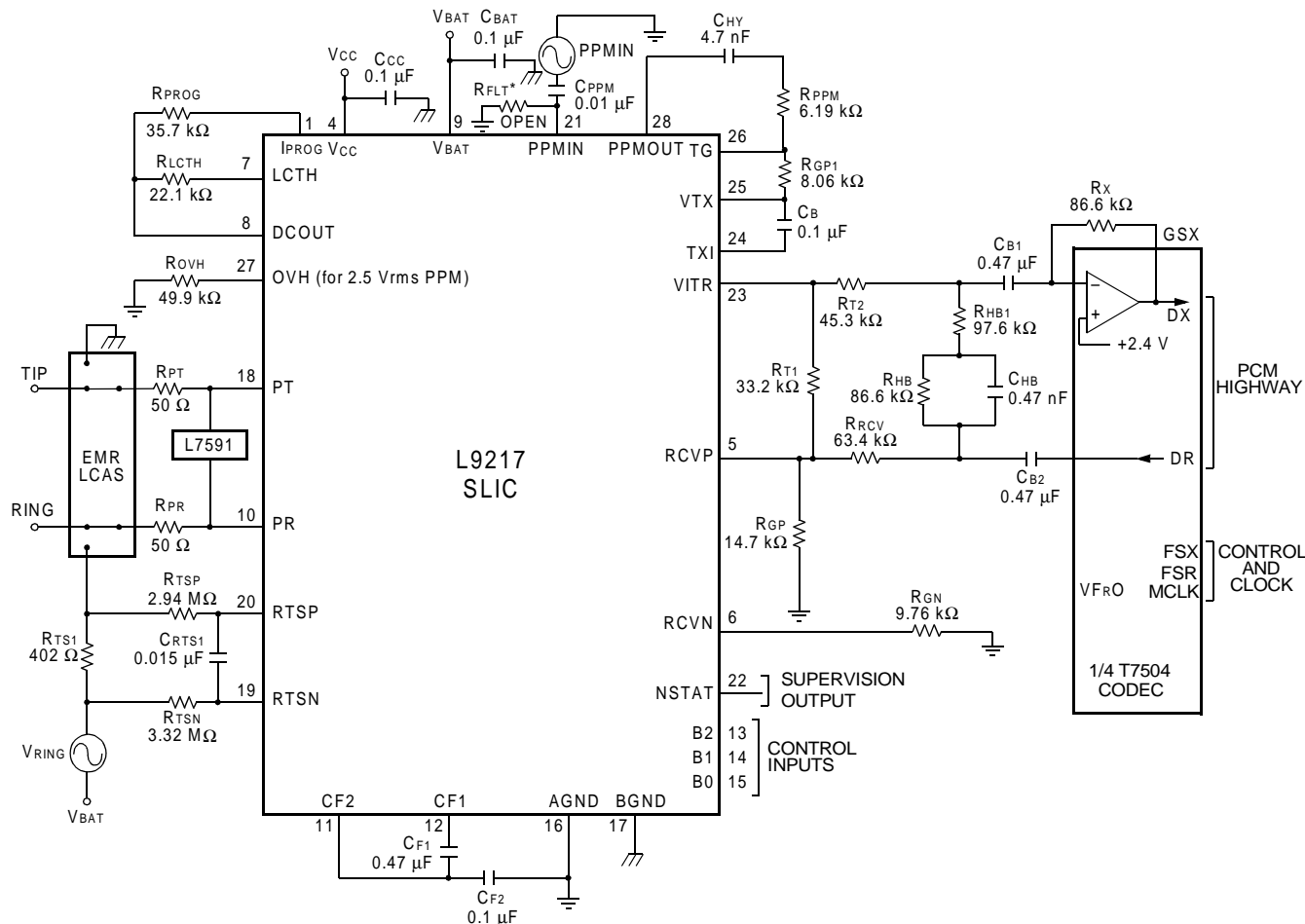

2797 (F)

\* Placeholder for potential resistor to form filter against PPM generator noise if necessary.

**Figure 11. Basic Loop Start Application Circuit Using T7504-Type Codec**

Table 10 shows the design parameters of the application circuit shown in Figure 11. Components that are adjusted to program these values are also shown.

**Table 10. 900  $\Omega$  Termination, 850  $\Omega$  + 50 nF Hybrid First-Generation Codec Design Parameters**

Design Parameter	Parameter Value	Components Adjusted
Loop Closure Threshold	10 mA	RLCTH
dc Loop Current Limit	20 mA	RPROG
ac Termination Impedance	900 $\Omega$	RT1, RGP, RRCV, RGP1
Hybrid Balance Line Impedance	850 $\Omega$ + 50 nF	CHB, RHB, RHB1
Transmit Gain	0 dBm	RT2, RX, RN1, RN2, CN
Receive Gain	-7 dBm	RRCV, RGP, RT1

**Applications** (continued)

**Table 11. Parts List for Loop Start Application Circuit Using T7504-Type Codec**

Name	Value	Function
<b>Integrated Circuits</b>		
SLIC	L9217	Subscriber loop interface circuit (SLIC).
Protector	Agere L7591	Secondary protection.
Ringing Relay	Agere L7581/2/3 or EMR	Switches ringing signals.
Codec	T7504	First-generation codec.
<b>Overvoltage Protection</b>		
RPT	50 $\Omega$ , Fusible	Protection resistor.
RPR	50 $\Omega$ , Fusible	Protection resistor.
<b>Power Supply</b>		
CBAT1	0.1 $\mu$ F, 20%, 100 V	V <sub>BAT</sub> filter capacitor.
CCC	0.1 $\mu$ F, 20%, 10 V	V <sub>CC</sub> filter capacitor.
CF1	0.47 $\mu$ F, 20%, 100 V	With CF <sub>2</sub> , improves idle-channel noise.
CF2	0.1 $\mu$ F, 20%, 100 V	With CF <sub>1</sub> , improves idle-channel noise.
<b>dc Characteristics</b>		
R <sub>PROG</sub>	35.7 k $\Omega$ , 1%, 1/16 W	Set low current limit.
<b>ac Characteristics</b>		
CB1	0.47 $\mu$ F, 20%, 10 V	ac/dc separation capacitor.
CB2	0.47 $\mu$ F, 20%, 10 V	ac/dc separation capacitor.
CB	0.1 $\mu$ F, 20%, 10 V	dc blocking capacitor.
RT1	33.2 k $\Omega$ , 1%, 1/16 W	With R <sub>GP</sub> and R <sub>RCV</sub> , sets ac termination impedance.
R <sub>RCV</sub>	63.4 k $\Omega$ , 1%, 1/16 W	With R <sub>GP</sub> and RT <sub>1</sub> , sets receive gain.
R <sub>GP</sub>	14.7 k $\Omega$ , 1%, 1/16 W	With RT <sub>1</sub> and R <sub>RCV</sub> , sets ac termination impedance and receive gain.
RT2	45.3 k $\Omega$ , 1%, 1/16 W	With R <sub>X</sub> , sets transmit gain in codec.
R <sub>X</sub>	86.6 k $\Omega$ , 1%, 1/16 W	With RT <sub>2</sub> , sets transmit gain in codec.
R <sub>HB1</sub>	97.6 k $\Omega$ , 1%, 1/16 W	Sets hybrid balance.
CHB	0.47 nF, 10%, 10 V	With R <sub>GS</sub> provides gain shaping for hybrid.
R <sub>HB</sub>	86.6 k $\Omega$ , 1%, 1/16 W	With C <sub>GS</sub> provides gain shaping for hybrid.
R <sub>GP1</sub>	8.06 k $\Omega$ , 1%, 1/16 W	Sets dc transmit gain of SLIC.
R <sub>GN</sub>	9.76 k $\Omega$ , 1%, 1/16 W	dc offset.
<b>Meter Pulse</b>		
CHY	4.7 nF, 20%, 10 V	Meter pulse rejection.
C <sub>PPM</sub>	0.01 $\mu$ F, 20%, 10 V	Meter pulse injection.
R <sub>PPM</sub>	6.19 k $\Omega$ , 1%, 1/16 W	Meter pulse rejection.
ROVH	49.9 k $\Omega$ , 1%, 1/16 W	Increases PPM overhead mode.
<b>Supervision</b>		
RLCTH	22.1 k $\Omega$ , 1%, 1/16 W	Sets loop closure (off-hook) threshold.
RTS1	402 $\Omega$ , 5%, 2 W	Ringing source series resistor.
C <sub>RTS1</sub>	0.015 $\mu$ F, 20%, 10 V	With RTS <sub>N</sub> , RTS <sub>P</sub> , forms filter pole.
RTS <sub>N</sub>	3.32 M $\Omega$ , 1%, 1/16 W	With RTS <sub>P</sub> , sets threshold.
RTS <sub>P</sub>	2.94 M $\Omega$ , 1%, 1/16 W	With CRTS <sub>1</sub> , RTS <sub>N</sub> , sets threshold.



Applications (continued)

A basic loop start reference circuit, using bused ringing with the L9217 SLIC and the T8536 third-generation codec, is shown in Figure 12.

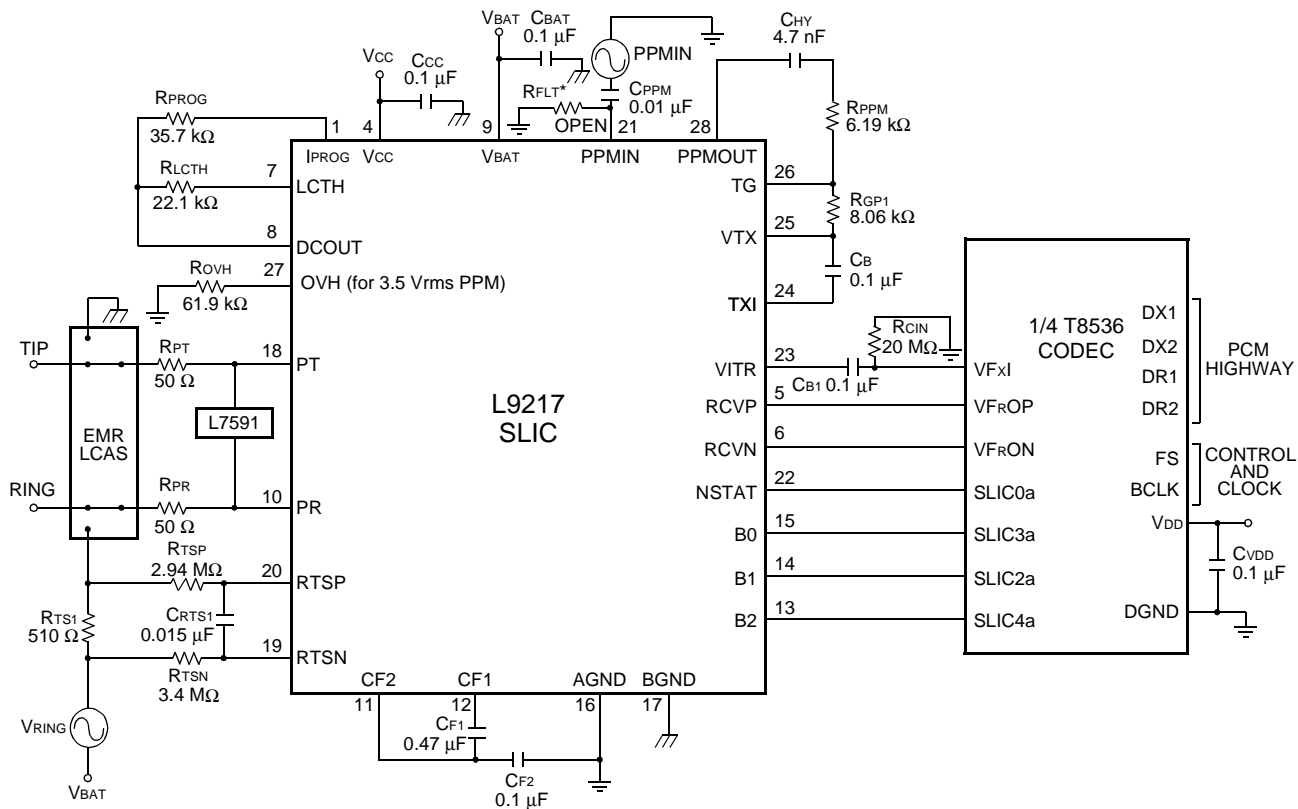

2798 (F)

\* Placeholder for potential resistor to form filter against PPM generator noise if necessary.

Figure 12. Basic Loop Start Application Circuit Using T8536-Type Codec

**Applications** (continued)

**Table 12. Parts List for Loop Start Application Circuit Using T8536-Type Codec**

Name	Value	Function
<b>Integrated Circuits</b>		
SLIC	L9217	Subscriber loop interface circuit (SLIC).
Protector	Agere L7591	Secondary protection.
Ringing Relay	Agere L7581/2/3 or EMR	Switches ringing signals.
Codec	T8536	Third-generation codec.
<b>Overvoltage Protection</b>		
RPT	50 $\Omega$ , Fusible	Protection resistor.
RPR	50 $\Omega$ , Fusible	Protection resistor.
<b>Power Supply</b>		
CBAT1	0.1 $\mu$ F, 20%, 100 V	V <sub>BAT</sub> filter capacitor.
CCC	0.1 $\mu$ F, 20%, 10 V	V <sub>CC</sub> filter capacitor.
CF1	0.47 $\mu$ F, 20%, 100 V	With CF <sub>2</sub> , improves idle-channel noise.
CF2	0.1 $\mu$ F, 20%, 100 V	With CF <sub>1</sub> , improves idle-channel noise.
<b>dc Characteristics</b>		
R <sub>PROG</sub>	35.7 k $\Omega$ , 1%, 1/16 W	Set low current limit.
<b>ac Characteristics</b>		
CB1	0.1 $\mu$ F, 20%, 10 V	ac/dc separation capacitor.
CB	0.1 $\mu$ F, 20%, 10 V	dc blocking capacitor.
R <sub>GP1</sub>	8.06 k $\Omega$ , 1%, 1/16 W	Sets dc transmit gain of SLIC.
R <sub>CIN</sub>	20 M $\Omega$ , 5%, 1/16 W	dc bias.
<b>Supervision</b>		
RLCTH	22.1 k $\Omega$ , 1%, 1/16 W	Sets loop closure (off-hook) threshold.
RTS1	510 $\Omega$ , 5%, 2 W	Ringing source series resistor.
CRTS1	0.015 $\mu$ F, 20%, 10 V	With RT <sub>SN</sub> and RT <sub>SP</sub> , forms second 2 Hz filter pole.
RTSN	3.4 M $\Omega$ , 1%, 1/16 W	With RT <sub>SP</sub> , sets threshold.
RTSP	2.94 M $\Omega$ , 1%, 1/16 W	With RT <sub>SN</sub> , sets threshold.
<b>Meter Pulse</b>		
CHY	4.7 nF, 20%, 10 V	Meter pulse rejection.
CPPM	0.01 $\mu$ F, 20%, 10 V	Meter pulse injection.
RPPM	6.19 k $\Omega$ , 1%, 1/16 W	Meter pulse rejection.
ROVH	61.9 k $\Omega$ , 1%, 1/16 W	Increases PPM overhead mode.

## Applications (continued)

### dc Applications

#### Battery Feed

The dc feed characteristic can be described by:

$$V_{T/R} = \frac{(|V_{BAT}| - V_{OH}) \times R_L}{R_L + 2R_P + R_{dc}}$$

$$I_L = \frac{|V_{BAT}| - V_{OH}}{R_L + 2R_P + R_{dc}}$$

where:

$I_L$  = dc loop current.

$V_{T/R}$  = dc loop voltage.

$|V_{BAT}|$  = battery voltage magnitude.

$V_{OH}$  = overhead voltage. This is the difference between the battery voltage and the open loop tip/ring voltage.

$R_L$  = loop resistance, not including protection resistors.

$R_P$  = protection resistor value.

$R_{dc}$  = SLIC internal dc feed resistance.

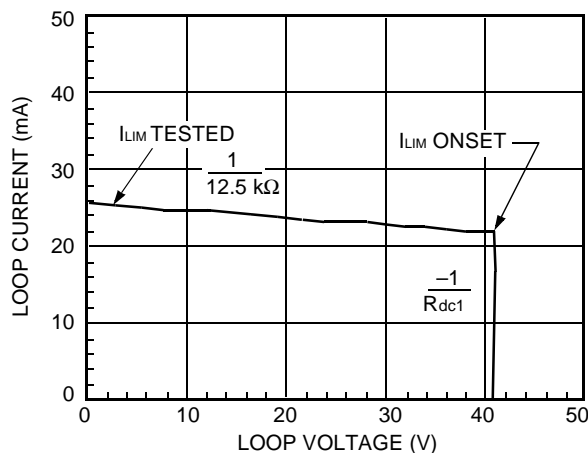

12-3050 (F).i

Note:  $V_{BAT} = -48$  V;  $I_{LIM} = 22$  mA;  $R_{dc1} = 115$   $\Omega$ .

Figure 13. Loop Current vs. Loop Voltage

Starting from the on-hook condition and going through to a short circuit, the curve passes through the following two regions:

Region 1: On-hook and low-loop currents. The slope corresponds to the dc resistance of the SLIC,  $R_{dc1}$  (default is 72  $\Omega$  typical). The open circuit voltage is the battery voltage minus the overhead voltage of the device,  $V_{OH}$  (default is 6.5 V typical). These values are suitable for most applications but can be adjusted if needed.

Region 2: Current limit. The dc current is limited to a starting value determined by external resistor  $R_{PROG}$ , an internal current source, and the gain from tip/ring to pin VITR. Current limit with a 100  $\Omega$  load is set by the following equation:

$$0.637 R_{PROG} (\text{k}\Omega) + 2 \text{ mA} = I_{LIM} \times (\text{mA})$$

#### Overhead Voltage

In order to drive an on-hook ac signal, the SLIC must set up the tip and ring voltage to a value less than the battery voltage. The amount that the open loop voltage is decreased relative to the battery is referred to as the overhead voltage. This is expressed as the following equation:

$$V_{OH} = |V_{BAT}| - (V_{PT} - V_{PR})$$

Without this buffer voltage, amplifier saturation will occur and the signal will be clipped. In modes without PPM, the L9217 is set to allow undistorted on-hook transmission of a 3.17 dBm signal into a 900  $\Omega$  loop impedance. A minimum 11.1 V overhead is needed to pass 3.5 Vrms meter pulse.

In high overhead and PPM modes, overhead is automatically increased to accommodate on-hook transmission of meter pulse signals. The increase in overhead is set by a resistor from pin OVH to ground. This is expressed as the following equation:

$$V_{OVH} (\text{V}) = 6.37 + 0.09535 \times R_{OVH} (\text{k}\Omega)$$

**Applications** (continued)

**dc Applications** (continued)

**Rate of Battery Reversal**

The rate of battery reversal is controlled or ramped by capacitors FB1 and FB2. A chart showing FB1/FB2 values versus typical ramp rate is given below. Leave FB1/FB2 open if it is not desired to ramp the rate of battery reversal.

**Table 13. FB1/FB2 Values vs. Typical Ramp Time**

CFB1/CFB2	Transition Time
0.01 $\mu\text{F}$	20 ms
0.1 $\mu\text{F}$	220 ms
0.22 $\mu\text{F}$	440 ms
0.47 $\mu\text{F}$	900 ms
1.0 $\mu\text{F}$	1.8 s
1.22 $\mu\text{F}$	2.25 s
1.3 $\mu\text{F}$	2.5 s
1.4 $\mu\text{F}$	2.7 s
1.6 $\mu\text{F}$	3.2 s

**Loop Range**

The equation below can be rearranged to provide the loop range for a required loop current:

$$R_L = \frac{|V_{BAT}| - V_{OH}}{I_L} - 2R_P - R_{DC}$$

**Off-Hook Detection**

The loop closure detection threshold is set by resistor  $R_{LTH}$ . The supervision output bit NSTAT is high in an on-hook condition. The off-hook comparator goes low during an off-hook condition:

$$I_{TR} \text{ (mA)} = 0.4167 R_{LTH} \text{ (k}\Omega\text{)} - 1.9 \text{ mA}$$

ACTIVE off-hook to on-hook

$$I_{TR} \text{ (mA)} = 0.4167 R_{LTH} \text{ (k}\Omega\text{)} + 2.7 \text{ mA}$$

SCAN on-hook to off-hook

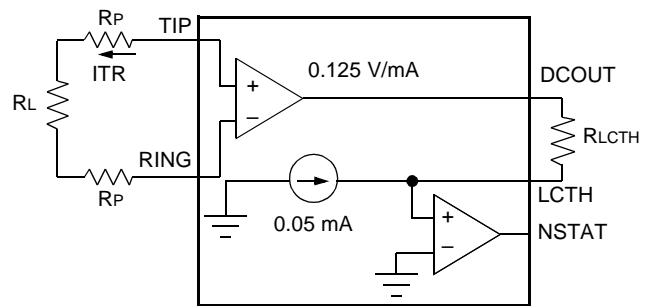

12-2553 (F)

**Figure 14. Off-Hook Detection Circuit**

## Applications (continued)

### dc Applications (continued)

#### Ring Trip Detection

The ring trip circuit is a comparator that has a special input section optimized for this application. The equivalent circuit is shown in Figure 15, along with its use in an application using unbalanced, battery-backed ringing.

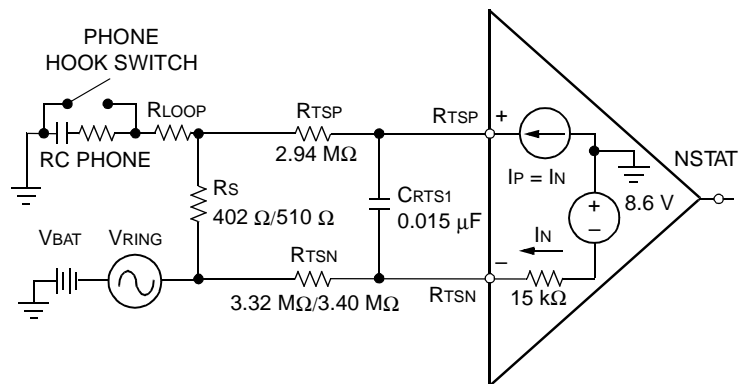

2799 (F)

**Figure 15. Ring Trip Equivalent Circuit and Equivalent Application**

Ring trip detection threshold is given by the following equation:

$$I_{TH} \text{ (mA)} = \frac{[RTSN(\text{M}\Omega) + 0.015 - RTSP(\text{M}\Omega)] \times [V_{BAT} - 8.6] \times 1000}{[RTSN(\text{M}\Omega) + 0.015] \times R_s}$$

### Longitudinal Balance

The SLIC is graded to certain longitudinal balance specifications. The numbers are guaranteed by testing (Figure 5 and Figure 8). However, for specific applications, the longitudinal balance may also be determined by termination impedance, protection resistance, and especially by the mismatch between protection resistors at tip and ring. This can be illustrated by the following equation:

$$LB = 20 \times \log \frac{(368 + RP) \times (368 + ZT - RP)}{368 \times (2 \times [ZT - 2 \times RP] \times \Delta + \epsilon)}$$

where:

LB: longitudinal balance.

RP: protection resistor value in  $\Omega$ .

ZT: magnitude of the termination impedance in  $\Omega$ .

$\epsilon$ : protection resistor mismatch in  $\Omega$ .

$\Delta$ : SLIC internal tip/ring sensing mismatch.

The  $\Delta$  can be calculated using the above equation with these exceptions:  $\epsilon = 0$ ,  $ZT = 600 \Omega$ ,  $RP = 100 \Omega$ , and the longitudinal balance specification on a specific code.

Now with  $\Delta$  available, the equation will predict the actual longitudinal balance for RP, ZT, and  $\epsilon$ .

Be aware that ZT may vary with frequency for complex impedance applications.

**Applications** (continued)

**Periodic Pulse Metering (PPM)**

Periodic pulse metering (PPM), also referred to as TTX, is input to the PPMIN input of the L9217. Upon application of appropriate logic control, this signal is presented to the tip/ring subscriber loop. The state of the L9217 may be changed while applying PPM signals. The L9217 assumes that a shaped PPM signal is applied to the PPMIN input.

Sufficient drive current is available in the tip and ring drive amplifiers to support 3.5 Vrms PPM signals into a 200 Ω load with a 45 mA dc current limit.

PPM signals are input to a separate PPMIN input. This input is controlled via the logic table. PPMIN is off during all states except the forward/reverse PPM active state. Thus, PPM signals may be present at all times, even during non-PPM active times. To apply PPM to tip/ring, from a normal overhead state first switch to a high overhead state without PPM; the overhead voltage at tip/ring will increase to 7 V to 13 V. The ramp up time of the overhead increase is on the order of hundreds of milliseconds. Thus, wait 1 s before applying the PPM signal by going to a PPM active high overhead state. Once in a high overhead, there is no timing requirement in switching in and out of a PPM active mode. Without the initial 1 s delay, AT/AR will get into saturation and PPM signal at T/R will get distorted, producing crosstalk in the handset.

PPM input signals may be a maximum 0.525 Vrms at PPMIN. The gain from PPMIN tip/ring is 10. Thus, for 2.5 Vrms at tip and ring, apply a 0.375 Vrms signal at PPMIN. The PPM signal should be ac coupled to PPMIN through a 0.01 μF capacitor.

When applied to tip and ring, the PPM signal will also be returned through the SLIC and will appear at the SLIC VITR output. The concern is that this high-voltage signal can overload the codec input and cause distortion of the (desired) ac signal. Therefore, some sort of PPM rejection scheme must be employed, see Figure 1. The L9217 outputs on the PPMOUT pin, which is the output of the PPM input amplifier. Connecting a resistor, R<sub>PPM</sub>, from PPMOUT to node TG will provide a path for a hybrid reject of the returned meter pulse signal. The return path from tip and ring to VITR for the PPM signal is through the internal AX amplifier. TG is the input to this amplifier. Through R<sub>PPM</sub>, by applying a PPM signal equal in magnitude, but 180 degrees out of phase to the returned PPM signal at TG, the PPM signal is cancelled, preventing overload at the codec input. Even if the cancellation is not perfect, the idea is to reduce the PPM signal so as not to overload the codec. Codecs typically have a low-pass filter at their input to reject any residual meter pulse signal.

The value of R<sub>PPM</sub> is selected by:

$$R_{PPM} = \{[(V_{PPMIN} \times 10)/(R_{PPMLOAD} + R_{DC} + 2R_P)]/201.2\}^{-1}$$

For undistorted transmission of meter pulse signals, increase the overhead as described in the Overhead Voltage section of this data sheet.

## Applications (continued)

### ac Design

#### Codec Types

At this point in the design, the codec needs to be selected. The interface network between the SLIC and codec can then be designed. There are four key ac design parameters. Termination impedance is the impedance looking into the 2-wire port of the line card. It is set to match the impedance of the telephone loop in order to minimize echo return to the telephone set. Transmit gain is measured from the 2-wire port to the PCM highway, while receive gain is done from the PCM highway to the transmit port. Finally, the hybrid balance network cancels the unwanted amount of the receive signal that appears at the transmit port.

Below is a brief codec feature summary.

**First-Generation Codecs.** These perform the basic filtering, A/D (transmit), D/A (receive), and  $\mu$ -law/A-law companding. They all have an op amp in front of the A/D converter for transmit gain setting and hybrid balance (cancellation at the summing node). Depending on the type, some have differential analog input stages, differential analog output stages, 5 V only or  $\pm 5$  V operation, and  $\mu$ -law/A-law selectability. These are available in single and quad designs. This type of codec requires continuous time analog filtering via external resistor/capacitor networks to set the ac design parameters. An example of this type of codec is the Agere T7504 quad 5 V only codec.

This type of codec tends to be the most economical in terms of piece part price, but tends to require more external components than a third-generation codec. Furthermore, ac parameters are fixed by the external R/C network, so software control of ac parameters is difficult.

**Third-Generation Codecs.** This class of devices includes all ac parameters set digitally under microprocessor control. Depending on the device, it may or may not have data control latches. Additional functionality sometimes offered includes tone plant generation and reception, TTX generation, test algorithms, and echo cancellation. Again, this type of codec may be 5 V only or  $\pm 5$  V operation, single quad or 16-channel, and  $\mu$ -law/A-law or 16-bit linear coding selectable. Examples of this type of codec are the Agere T8535/6 (5 V only, quad, standard features), T8533/4 (5 V only, quad with echo cancellation), and the T8531/36 (5 V only 16-channel with self-test).

### ac Interface Network

The ac interface network between the L9217 and the codec will vary depending on the codec selected. With a first-generation codec, the interface between the L9217 and codec actually sets the ac parameters. With a third-generation codec, all ac parameters are set digitally, internal to the codec; thus, the interface between the L9217 and this type of codec is designed to avoid overload at the codec input in the transmit direction, and to optimize signal-to-noise ratio (S/N) in the receive direction.

#### Receive Interface

Because the design requirements are very different with a first- or third-generation codec, the L9217 is offered with two different receive gains. Each receive gain was chosen to optimize, in terms of external components required, the ac interface between the L9217 and the codec.

With a first-generation codec, the termination impedance is set by providing gain shaping through a feedback network from the SLIC VITR output to the SLIC RCVN/RCVP inputs. The L9217 provides a transconductance from T/R to VITR in the transmit direction and a single ended to differential gain in the receive direction from either RCVN or RCVP to T/R. Assuming a short from VITR to RCVN or RCVP, the maximum impedance that is seen looking into the SLIC is the product of the SLIC transconductance times the SLIC receive gain, plus the protection resistors. The various specified termination impedance can range over the voice band as low as 300  $\Omega$  up to over 1000  $\Omega$ . Thus, if the SLIC gains are too low, it will be impossible to synthesize the higher termination impedances. Furthermore, the termination that is achieved will be far less than what is calculated by assuming a short for SLIC output to SLIC input. In the receive direction, in order to control echo, the gain is typically a loss, which requires a loss network at the SLIC RCVN/RCVP inputs, which will reduce the amount of gain that is available for termination impedance. For this reason a high-gain SLIC is required with a first-generation codec.

**Applications** (continued)

**ac Design** (continued)

**Receive Interface** (continued)

With a third-generation codec, the line card designer has different concerns. To design the ac interface, the designer must first decide upon all termination impedance, hybrid balances, and transmission level points (TLP) requirements that the line card must meet. In the transmit direction, the only concern is that the SLIC does not provide a signal that is too hot and overloads the codec input. Thus, for the highest TLP that is being designed to, given the SLIC gain, the designer, as a function of voice band frequency, must ensure that the codec is not overloaded. With a given TLP and a given SLIC gain (if the signal will cause a codec overload), the designer must insert some sort of loss, typically a resistor divider, between the SLIC output and codec input.

In the receive direction, the issue is to optimize S/N. Again, the designer must consider all the considered TLPs. The idea is, for all desired TLPs, to run the codec at or as close as possible to its maximum output signal, to optimize the S/N. Remember noise floor is constant, so the hotter the signal from the codec, the better the

S/N. The problem is, if the codec is feeding a high-gain SLIC, either an external resistor divider is needed to knock the gain down to meet the TLP requirements, or the codec is not operating near maximum signal levels, thus compromising the S/N.

It appears the solution is to have a SLIC with a low gain, especially in the receive direction. This will allow the codec to operate near its maximum output signal (to optimize S/N), without an external resistor divider (to minimize cost).

Note also that some third-generation codecs require the designer to provide an inherent resistive termination via external networks. The codec will then provide gain shaping, as a function of frequency to meet the return loss requirements. Further stability issues may add external components or excessive ground plane requirements to the design.

To meet the unique requirements of both types of codecs, the L9217 offers two receive gain choices. These receive gains are mask programmable at the factory and are offered as two different code variations. For interface with a first-generation codec, the L9217A is offered with a receive gain of 7.86. For interface with a third-generation codec, the L9217G is offered with a receive gain of 2. In either case, the transconductance in the transmit direction, or the transmit gain is 403 Ω.

**Example 1: Real Termination (First-Generation Codec)**

ac equivalent circuits for real termination using a T7504 codec is shown in Figure 15.

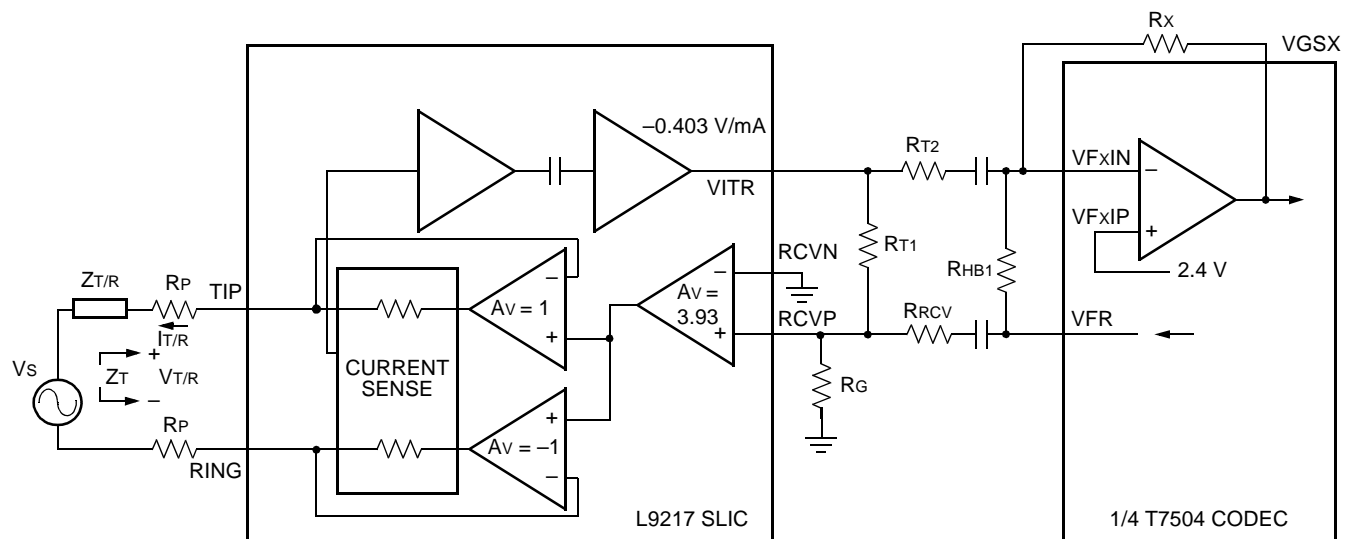

12-3581 (F).Cm

**Figure 16. ac Equivalent Circuit**



## Applications (continued)

### ac Design (continued)

#### Example 1: Real Termination (First-Generation Codec) (continued)

The following design equations refer to the circuit in Figure 16. Use these to synthesize real termination impedance.

#### Termination Impedance:

$$Z_T = \frac{V_{T/R}}{-I_{T/R}}$$

$$Z_T = 2R_P + \frac{3168}{1 + \frac{R_{T3}}{R_{GP}} + \frac{R_{T3}}{R_{RCV}}}$$

#### Receive Gain:

$$g_{rcv} = \frac{V_{T/R}}{V_{fr}}$$

$$g_{rcv} = \frac{7.86}{\left(1 + \frac{R_{RCV}}{R_{T3}} + \frac{R_{RCV}}{R_{GP}}\right) \left(1 + \frac{Z_T}{Z_{T/R}}\right)}$$

#### Transmit Gain:

$$g_{tx} = \frac{V_{GSX}}{V_{T/R}}$$

$$g_{tx} = \frac{R_X}{R_{T6}} \times \frac{403}{Z_T}$$

#### Hybrid Balance:

$$h_{bal} = 20 \log \frac{V_{GSX}}{V_{T/R}}$$

To optimize the hybrid balance, the sum of the currents at the VFX input of the codec op amp should be set to 0. The following expressions assume the test network is the same as the termination impedance:

$$R_{HB} = \frac{R_X}{g_{tx} \times g_{rcv}}$$

$$h_{bal} = 20 \log \left( \frac{R_X}{R_{HB}} - g_{tx} \times g_{rcv} \right)$$

**Applications** (continued)

**ac Design** (continued)

**Example 2: Complex Termination (First-Generation Codec)**

Below are design equations for complex termination (see Figure 17 and Figure 18).

$$R_{T1} = 2R_P + \frac{7.86}{201.2} \cdot \left( \frac{1}{1 + \frac{R_{T3}}{R_{GP}} + \frac{R_{T3}}{R_{RCV}}} - \frac{1}{1 + \frac{R_{N1}}{R_{N2}}} \right) R_{TGP} \parallel R_{TGS}$$

$$R_{T2} = \frac{7.86}{201.2} + \left( \frac{R_{TGP}/R_{TGS}}{1 + \frac{R_{T3}}{R_{GP}} + \frac{R_{T3}}{R_{RCV}}} + \frac{1}{1 + \frac{R_{N1}}{R_{N2}}} \right) R_{TGP} \parallel R_{TGS}$$

$$\frac{1}{C_T} = \frac{7.86}{201.2} \left( \frac{1}{C_{N1}(R_{N1} + R_{N2})^2} R_{TGP} \parallel R_{TGS} + \frac{1}{C_{TG}} \cdot \left( \frac{R_{TGP}}{R_{TGP} + R_{TGS}} \right)^2 \cdot \left( \frac{1}{1 + \frac{R_{T3}}{R_{GP}} + \frac{R_{T3}}{R_{RCV}}} - \frac{1}{1 + \frac{R_{N1}}{R_{N2}}} \right) \right)$$

$$g_{tx} = \frac{R_X}{R_{T6}} \frac{1}{201.2} \frac{Z_{TG}}{Z_T}$$

$$g_{rcv} = \frac{7.86}{1 + \frac{R_{RCV}}{R_{T3}} + \frac{R_{RCV}}{R_{GP}}} \times \frac{1}{1 + \frac{Z_T}{Z_{T/R}}}$$

$$h_{bal} = 20 \log \left( \frac{R_X}{R_{HB}} - g_{tx} \times g_{rcv} \right)$$

where:

$$Z_{T/R} = R_1 + R_2 \parallel C$$

$$Z_{TG} = R_{TGP} \parallel (R_{TGS} + C_G)$$

$$R_{TGP} = 8.06 \text{ k}\Omega$$

$$R_{TGS} = \frac{R_1}{R_2} R_{TGP}$$

$$C_G = \frac{R_2^2}{R_{TGP}(R_1 + R_2)} \times C$$

and

$$C_{NRN2} = \frac{2R_P}{3167} C_G R_{TGP}$$

$$R_{N1} = R_{N2} \left[ \frac{3167}{2R_P} \left( \frac{R_{TGS}}{R_{TGP}} \right) - 1 \right]$$

The equations above do not include the blocking capacitors.

**Applications** (continued)

**ac Design** (continued)

**Example 2: Complex Termination (First-Generation Codec)** (continued)

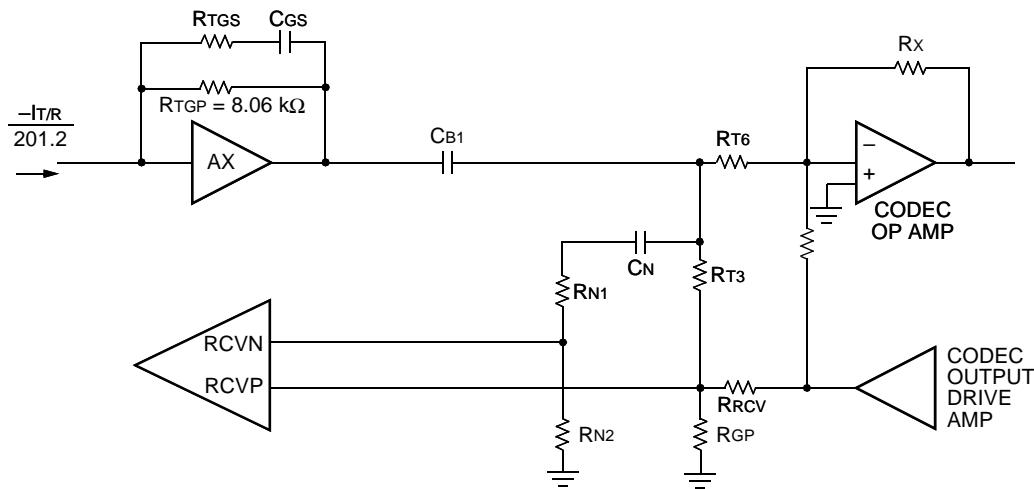

5-6401 (F).I

**Figure 17. Interface Circuit Using First-Generation Codec ( $\pm 5 \text{ V}$  Codec)**

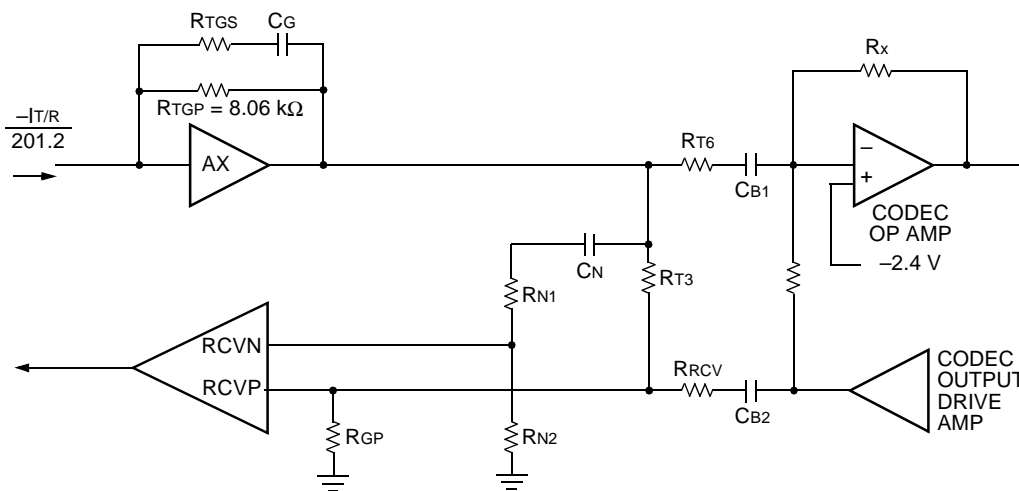

5-6400 (F).o

**Figure 18. Interface Circuit Using First-Generation Codec (5 V Only Codec)**

## Applications (continued)

### Power Derating

Operating temperature range, maximum current limit, maximum battery voltage, minimum dc loop, and protection resistor values will influence the overall thermal performance. This section shows the relevant design equations and considerations in evaluating the SLIC thermal performance.

Consider the L9217 SLIC in a 28-pin PLCC package. The thermal resistance on a 2-layer board with natural convection is 43 °C/W.

The SLIC will enter the thermal shutdown state at a minimum of 150 °C. The thermal shutdown design should ensure that the SLIC temperature does not reach 150 °C under normal operating conditions.

Assume a maximum ambient operating temperature of 85 °C, a design current limit of 25 mA, and a maximum battery of -52 V. Furthermore, assume a (worst-case) minimum dc loop of 200 Ω, and that 50 Ω protection resistors are used at both tip and ring.

1.  $T_{TSD} - T_{AMBIENT(max)}$  = allowed thermal rise.

$$150\text{ °C} - 85\text{ °C} = 65\text{ °C}$$

2. Allowed thermal rise = package thermal impedance • SLIC power dissipation.

$$65\text{ °C} = 43\text{ °C/W} \bullet \text{SLIC power dissipation}$$

$$\text{SLIC power dissipation (P}_{DISS}) = 1.51\text{ W}$$

Thus, if the total power dissipated in the SLIC is less than 1.51 W, it will not enter the thermal shutdown state. Total SLIC power is calculated as:

$$\begin{aligned} \text{Total P}_{DISS} &= \text{Maximum battery} \bullet \text{maximum} \\ &\text{current limit (including effects of accuracy)} \\ &+ \text{SLIC quiescent power} \end{aligned}$$

For the L9217, SLIC quiescent power ( $P_Q$ ) is maximum at 0.175 W. Thus,

$$\text{Total P}_{DISS} = (-52\text{ V} \bullet [25\text{ mA} \bullet 1.08]) + 0.175\text{ W}$$

$$\text{Total P}_{DISS} = 1.404\text{ W} + 0.175\text{ W}$$

$$\text{Total P}_{DISS} = 1.579\text{ W}$$

The power dissipated in the SLIC is the total power dissipation minus the power that is dissipated in the loop.

$$\text{SLIC P}_{DISS} = \text{Total power} - \text{loop power}$$

$$\text{Loop power} = (I_{LIM})^2 \bullet (R_{dcLOOP\ min} + 2R_P)$$

$$\begin{aligned} \text{Loop power} &= (25\text{ mA} \bullet 1.08)^2 \bullet \\ &(200\ \Omega + 100\ \Omega) \end{aligned}$$

$$\text{Loop power} = 0.219\text{ W}$$

$$\text{SLIC power} = 1.579\text{ W} - 0.219\text{ W} = 1.36$$

$$\text{SLIC power} = 1.36\text{ W} < 1.51\text{ W}$$

Thus, in this example, the thermal design ensures that the SLIC will not enter the thermal shutdown state.

### Pin-for-Pin Compatibility with L9218/L9219

The L9217 can be a pin-for-pin replacement for the L9218/L9219. The exceptions are as follows: L9217 has three logic control inputs: B0, B1, and B2. The L9218 has only two logic control inputs: B0 and B1. Pin 13 in L9218 is NC, so a connection between the controller and pin 13 will not affect L9218 operation. In L9217, pin 28 is PPMOUT, pin 21 is PPMIN, and pin 27 is OVH. In L9218/9, pin 28 is NC, pin 21 is NC, and pin 27 is TSD

### PCB Layout Information

Make the leads to BGND and  $V_{BAT}$  as wide as possible for thermal and electrical reasons. Also, maximize the amount of PCB copper in the area of (and specifically on) the leads connected to this device for the lowest operating temperature.

When powering the device, make certain that no external potential creates a voltage on any pin of the device that exceeds the device ratings. In this application, some of the conditions that cause such potentials during powerup are the following:

1. An inductor connected to PT and PR (this can force an overvoltage on  $V_{BAT}$  through the protection devices if the  $V_{BAT}$  connection chatters).
2. Inductance in the  $V_{BAT}$  lead (this could resonate with the  $V_{BAT}$  filter capacitor to cause a destructive overvoltage).

This device is normally used on a circuit card that is subjected to hot plug-in, meaning the card is plugged into a biased backplane connector. In order to prevent damage to the IC, all ground connections must be applied before, and removed after, all other connections.

## Outline Diagram

### 28-Pin PLCC

Dimensions are in millimeters.

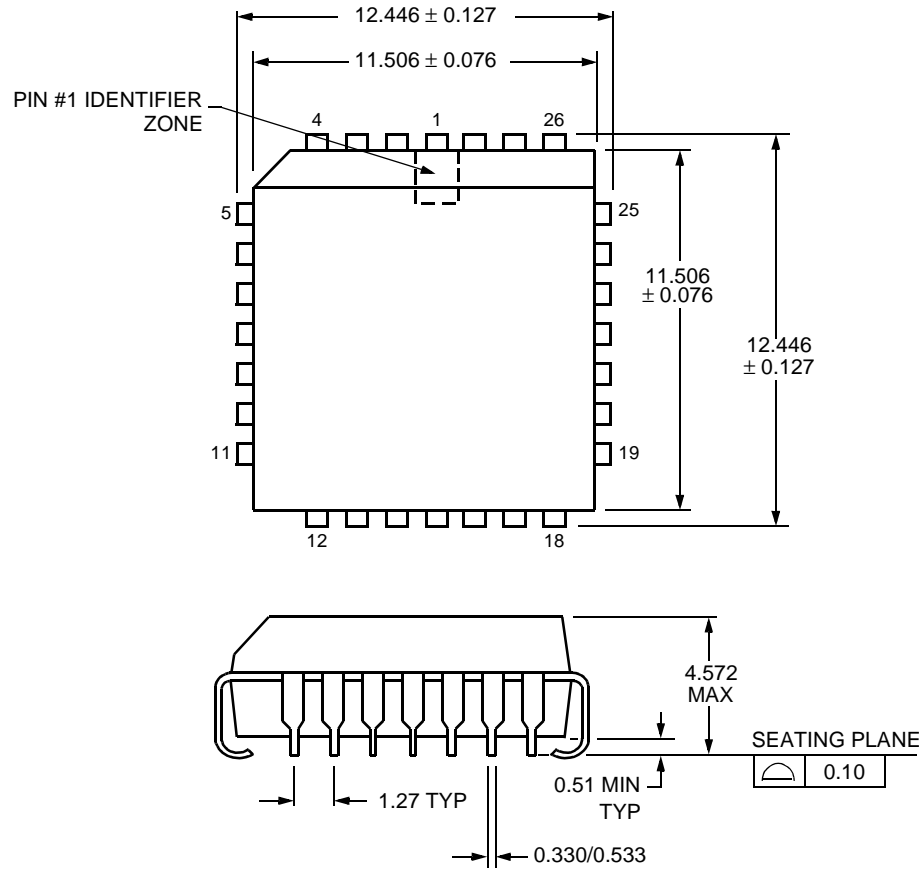

5-2506 (F) r.8

## Ordering Information

Device	Package	Comcode
LUCL9217AAR-DT	28-Pin PLCC (Tape & Reel, Dry-bagged) Gain of 8	108760737
LUCL9217AAR-D	28-Pin PLCC (Dry-bagged) Gain of 8	108760729
LUCL9217GAR-DT	28-Pin PLCC (Tape & Reel, Dry-bagged) Gain of 2	108760760
LUCL9217GAR-D	28-Pin PLCC (Dry-bagged) Gain of 2	108760752

*IEEE* is a registered trademark of The Institute of Electrical and Electronics Engineers, Inc.  
*HP* is a registered trademark of Hewlett-Packard Company.

For additional information, contact your Agere Systems Account Manager or the following:

INTERNET: <http://www.agere.com>

E-MAIL: [docmaster@agere.com](mailto:docmaster@agere.com)

N. AMERICA: Agere Systems Inc., 555 Union Boulevard, Room 30L-15P-BA, Allentown, PA 18109-3286

**1-800-372-2447**, FAX 610-712-4106 (In CANADA: **1-800-553-2448**, FAX 610-712-4106)

ASIA: Agere Systems Hong Kong Ltd., Suites 3201 & 3210-12, 32/F, Tower 2, The Gateway, Harbour City, Kowloon

Tel. **(852) 3129-2000**, FAX (852) 3129-2020

CHINA: **(86) 21-5047-1212** (Shanghai), **(86) 10-6522-5566** (Beijing), **(86) 755-695-7224** (Shenzhen)

JAPAN: **(81) 3-5421-1600** (Tokyo), KOREA: **(82) 2-767-1850** (Seoul), SINGAPORE: **(65) 778-8833**, TAIWAN: **(886) 2-2725-5858** (Taipei)

EUROPE: Tel. **(44) 7000 624624**, FAX (44) 1344 488 045

Agere Systems Inc. reserves the right to make changes to the product(s) or information contained herein without notice. No liability is assumed as a result of their use or application.

This datasheet has been download from:

[www.datasheetcatalog.com](http://www.datasheetcatalog.com)

Datasheets for electronics components.