

- **Controlled Baseline**
  - One Assembly/Test Site, One Fabrication Site
- **Extended Temperature Performance of –40°C to 125°C**
- **Enhanced Diminishing Manufacturing Sources (DMS) Support**
- **Enhanced Product-Change Notification**
- **Qualification Pedigree†**
- **ESD Protection Exceeds 500 V Per MIL-STD-883, Method 3015; Exceeds 200 V Using Machine Model (C = 200 pF, R = 0)**
- **Low Supply-Current Drain Independent of Supply Voltage . . . 0.7 mA Typ**
- **Common-Mode Input Voltage Range Includes Ground, Allowing Direct Sensing Near Ground**
- **Differential Input Voltage Range Equal to Maximum-Rated Supply Voltage:**
  - Non-V Devices . . . ±26 V
  - V-Suffix Devices . . . ±32 V
- **Low Input Bias and Offset Parameters:**
  - Input Offset Voltage . . . 3 mV Typ
  - Input Offset Current . . . 2 nA Typ
  - Input Bias Current . . . 20 nA Typ
- **Open-Loop Differential Voltage Amplification . . . 100 V/mV Typ**
- **Internal Frequency Compensation**

† Component qualification in accordance with JEDEC and industry standards to ensure reliable operation over an extended temperature range. This includes, but is not limited to, Highly Accelerated Stress Test (HAST) or biased 85/85, temperature cycle, autoclave or unbiased HAST, electromigration, bond intermetallic life, and mold compound life. Such qualification testing should not be viewed as justifying use of this component beyond specified performance and environmental limits.

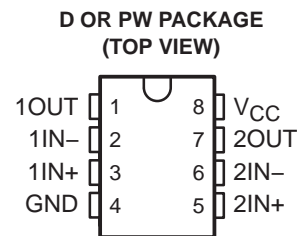

## description/ordering information

This device consists of two independent, high-gain, frequency-compensated operational amplifiers designed to operate from a single supply over a wide range of voltages. Operation from split supplies is possible as long as the difference between the two supplies is 3 V to 26 V (3 V to 32 V for V-suffix devices), and V<sub>CC</sub> is at least 1.5 V more positive than the input common-mode voltage. The low supply-current drain is independent of the magnitude of the supply voltage.

Applications include transducer amplifiers, dc amplification blocks, and all the conventional operational amplifier circuits that now can be implemented more easily in single-supply-voltage systems. For example, these devices can be operated directly from the standard 5-V supply used in digital systems and easily provide the required interface electronics without additional ±5-V supplies.

## ORDERING INFORMATION

T <sub>A</sub>	V <sub>IO</sub> max AT 25°C	MAX V <sub>CC</sub>	PACKAGE‡		ORDERABLE PART NUMBER	TOP-SIDE MARKING
–40°C to 125°C	7 mV	26 V	SOIC (D)	Tape and reel	LM2904QDREP	2904EP
	7 mV	26 V	TSSOP (PW)	Tape and reel	LM2904QPWREP	2904EP
	7 mV	32 V	SOIC (D)	Tape and reel	LM2904VQDREP	2904VEP
	7 mV	32 V	TSSOP (PW)	Tape and reel	LM2904VQPWREP	2904VEP
	2 mV	32 V	SOIC (D)	Tape and reel	LM2904AVQDREP	2904AVE
	2 mV	32 V	TSSOP (PW)	Tape and reel	LM2904AVQPWREP	2904AVE

‡ Package drawings, standard packing quantities, thermal data, symbolization, and PCB design guidelines are available at [www.ti.com/sc/package](http://www.ti.com/sc/package).



Please be aware that an important notice concerning availability, standard warranty, and use in critical applications of Texas Instruments semiconductor products and disclaimers thereto appears at the end of this data sheet.

PRODUCTION DATA information is current as of publication date. Products conform to specifications per the terms of Texas Instruments standard warranty. Production processing does not necessarily include testing of all parameters.



POST OFFICE BOX 655303 • DALLAS, TEXAS 75265

Copyright © 2004, Texas Instruments Incorporated

# LM2904-EP DUAL OPERATIONAL AMPLIFIER

SLOS448 – OCTOBER 2004

symbol (each amplifier)

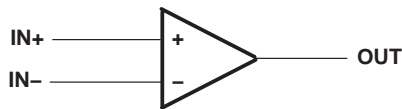

schematic (each amplifier)

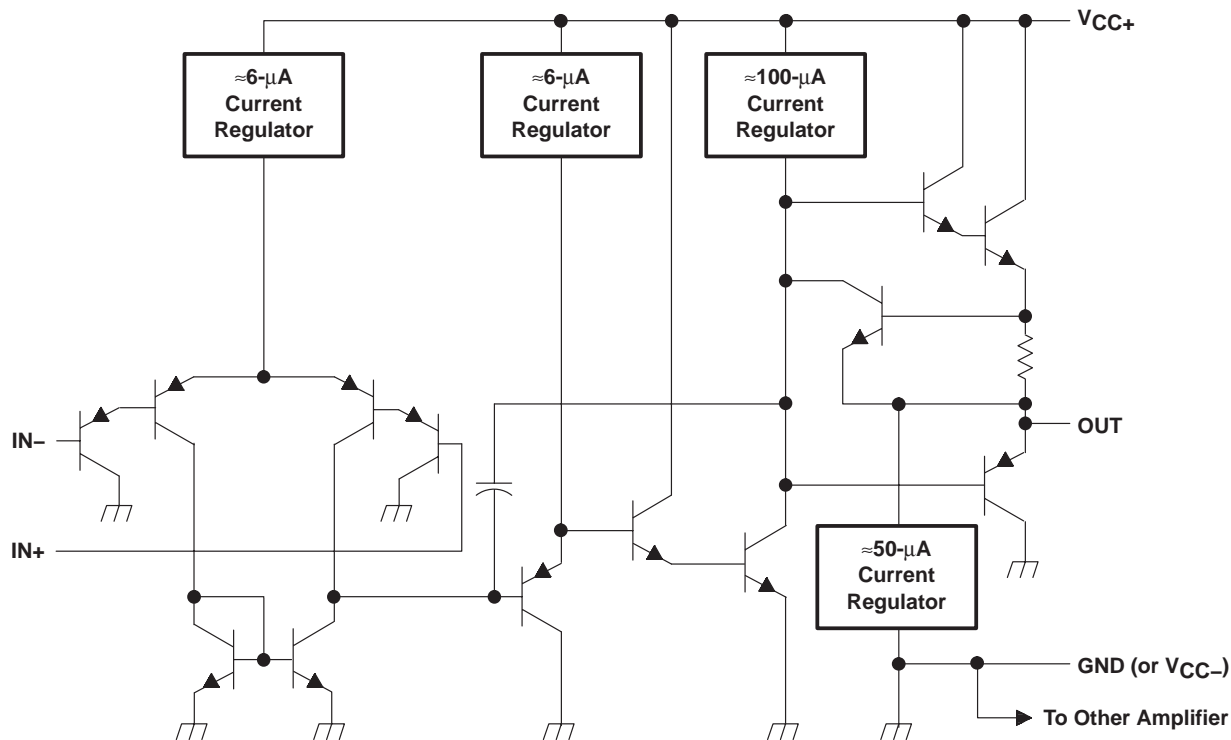

COMPONENT COUNT	
Epi-FET	1
Diodes	2
Resistors	7
Transistors	51
Capacitors	2

**absolute maximum ratings over operating free-air temperature (unless otherwise noted)†**

Supply voltage, $V_{CC}$ (see Note 1): Non-V devices	26 V
V-suffix devices	32 V
Differential input voltage, $V_{ID}$ (see Note 2): Non-V devices	$\pm 26$ V
V-suffix devices	$\pm 32$ V
Input voltage range, $V_I$ (either input): Non-V devices	-0.3 V to 26 V
V-suffix devices	-0.3 V to 32 V
Duration of output short circuit (one amplifier) to ground at (or below) 25°C	
free-air temperature ( $V_{CC} \leq 15$ V) (see Note 3)	Unlimited
Operating virtual junction temperature, $T_J$	150°C
Package thermal impedance, $\theta_{JA}$ (see Notes 4 and 5): D package	97°C/W
PW package	149°C/W
Operating free-air temperature range, $T_A$ (see Figure 1)	-40°C to 125°C
Storage temperature range, $T_{Stg}$	-65°C to 150°C

† Stresses beyond those listed under “absolute maximum ratings” may cause permanent damage to the device. These are stress ratings only, and functional operation of the device at these or any other conditions beyond those indicated under “recommended operating conditions” is not implied. Exposure to absolute-maximum-rated conditions for extended periods may affect device reliability.

- NOTES:
1. All voltage values, except differential voltages and  $V_{CC}$  specified for measurement of  $I_{OS}$ , are with respect to the network ground terminal.
  2. Differential voltages are at  $IN+$  with respect to  $IN-$ .
  3. Short circuits from outputs to  $V_{CC}$  can cause excessive heating and eventual destruction.
  4. Maximum power dissipation is a function of  $T_J(max)$ ,  $\theta_{JA}$ , and  $T_A$ . The maximum allowable power dissipation at any allowable ambient temperature is  $P_D = (T_J(max) - T_A)/\theta_{JA}$ . Operating at the absolute maximum  $T_J$  of 150°C can affect reliability.
  5. The package thermal impedance is calculated in accordance with JESD 51-7.

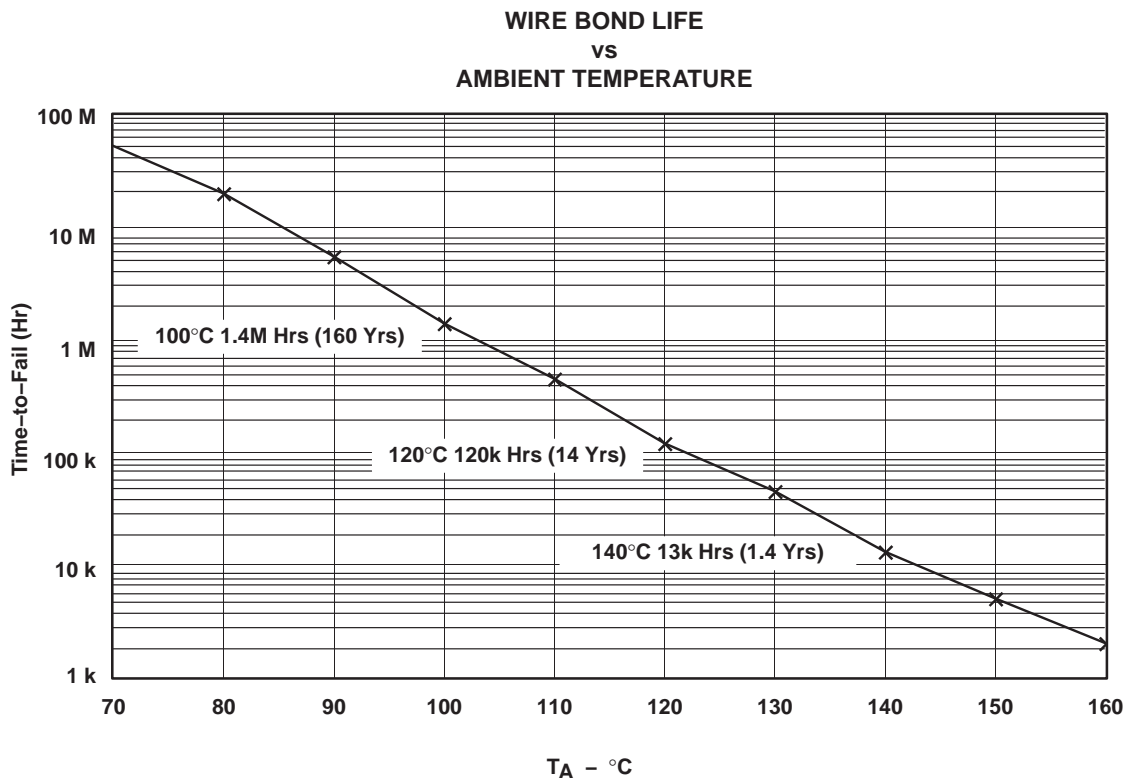

**Figure 1. Estimated Wire Bond Life**

# LM2904-EP DUAL OPERATIONAL AMPLIFIER

SLOS448 – OCTOBER 2004

## electrical characteristics at specified free-air temperature, $V_{CC} = 5\text{ V}$ (unless otherwise noted)

PARAMETER	TEST CONDITION†		$T_A$ ‡	MIN	TYP§	MAX	UNIT
$V_{IO}$ Input offset voltage	$V_{CC} = 5\text{ V to MAX, } V_{IC} = V_{ICR(\min)}, V_O = 1.4\text{ V}$	Non-A devices	25°C		3	7	mV
			Full range			10	
		A-suffix devices	25°C		1	2	
			Full range			4	
$\alpha_{V_{IO}}$ Average temperature coefficient of input offset voltage			Full range		7		$\mu\text{V}/^\circ\text{C}$
$I_{IO}$ Input offset current	$V_O = 1.4\text{ V}$	Non-V devices	25°C		2	50	nA
			Full range			300	
		V-suffix devices	25°C		5	50	
			Full range			150	
$\alpha_{I_{IO}}$ Average temperature coefficient of input offset current			Full range		10		$\text{pA}/^\circ\text{C}$
$I_{IB}$ Input bias current	$V_O = 1.4\text{ V}$		25°C	-20	-250	nA	
			Full range		-500		
$I_B$ Drift			Full range		50		$\text{pA}/^\circ\text{C}$
$V_{ICR}$ Common-mode input voltage range	$V_{CC} = 5\text{ V to MAX}$		25°C	0 to $V_{CC} - 1.5$		V	
			Full range		0 to $V_{CC} - 2$		
$V_{OH}$ High-level output voltage	$R_L \geq 10\text{ k}\Omega$		25°C	$V_{CC} - 1.5$		V	
		$V_{CC} = \text{MAX, Non-V devices}$	$R_L = 2\text{ k}\Omega$	Full range	22		
			$R_L \geq 10\text{ k}\Omega$		23 24		
		$V_{CC} = \text{MAX, V-suffix devices}$	$R_L = 2\text{ k}\Omega$	Full range	26		
$R_L \geq 10\text{ k}\Omega$	27 28						
$V_{OL}$ Low-level output voltage	$R_L \leq 10\text{ k}\Omega$		Full range		5	20	mV
$A_{VD}$ Large-signal differential voltage amplification	$V_{CC} = 15\text{ V, } V_O = 1\text{ V to } 11\text{ V, } R_L \geq 2\text{ k}\Omega$		25°C	25	100	$\text{V/mV}$	
			Full range		15		
CMRR Common-mode rejection ratio	$V_{CC} = 5\text{ V to MAX, } V_{IC} = V_{ICR(\min)}$		25°C	65	80		dB
$k_{SVR}$ Supply-voltage rejection ratio ( $\Delta V_{DD}/\Delta V_{IO}$ )	$V_{CC} = 5\text{ V to MAX}$		25°C	65	100		dB
$V_{O1}/V_{O2}$ Crosstalk attenuation	$f = 1\text{ kHz to } 20\text{ kHz}$		25°C		120		dB
$I_O$ Output current	$V_{CC} = 15\text{ V, } V_{ID} = 1\text{ V, } V_O = 0$		25°C	-20	-30	mA	
			Full range		-10		
	$V_{CC} = 15\text{ V, } V_{ID} = -1\text{ V, } V_O = 15\text{ V}$		25°C	10	20		
			Full range		5		
	$V_{ID} = -1\text{ V, } V_O = 200\text{ mV}$		25°C	12	40	$\mu\text{A}$	
$I_{OS}$ Short-circuit output current	$V_{CC}$ at 5 V, GND at -5 V, $V_O = 0$		25°C		$\pm 40$	$\pm 60$	mA
$I_{CC}$ Supply current (two amplifiers)	$V_O = 2.5\text{ V, No load}$		Full range		0.7	1.2	mA
	$V_{CC} = \text{MAX, } V_O = 0.5 V_{CC}, \text{ No load}$				1	2	

† All characteristics are measured under open-loop conditions, with zero common-mode input voltage, unless otherwise specified. MAX  $V_{CC}$  for testing purposes is 26 V for non-V devices and 32 V for V-suffix devices.

‡ Full range is -40°C to 125°C for LM2904Q.

§ All typical values are at  $T_A = 25^\circ\text{C}$ .



operating conditions,  $V_{CC} = \pm 15\text{ V}$ ,  $T_A = 25^\circ\text{C}$

PARAMETER		TEST CONDITIONS	TYP	UNIT
SR	Slew rate at unity gain	$R_L = 1\text{ M}\Omega$ , $C_L = 30\text{ pF}$ , $V_I = \pm 10\text{ V}$ (see Figure 2)	0.3	$\text{V}/\mu\text{s}$
$B_1$	Unity-gain bandwidth	$R_L = 1\text{ M}\Omega$ , $C_L = 20\text{ pF}$ (see Figure 2)	0.7	MHz
$V_n$	Equivalent input noise voltage	$R_S = 100\ \Omega$ , $V_I = 0\text{ V}$ , $f = 1\text{ kHz}$ (see Figure 3)	40	$\text{nV}/\sqrt{\text{Hz}}$

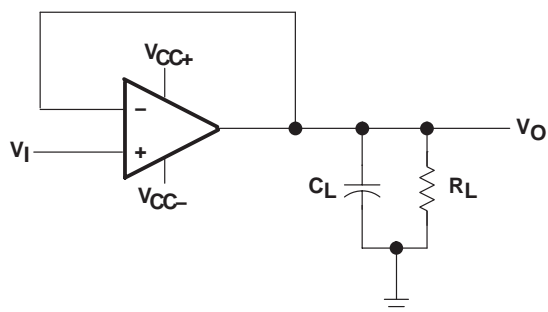

Figure 2. Unity-Gain Amplifier

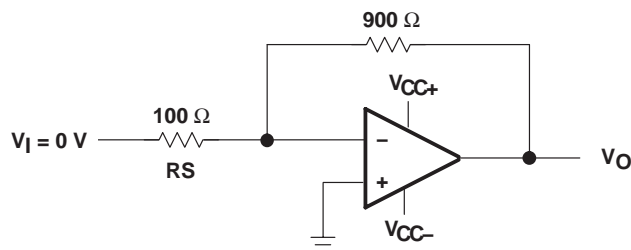

Figure 3. Noise-Test Circuit

## IMPORTANT NOTICE

Texas Instruments Incorporated and its subsidiaries (TI) reserve the right to make corrections, modifications, enhancements, improvements, and other changes to its products and services at any time and to discontinue any product or service without notice. Customers should obtain the latest relevant information before placing orders and should verify that such information is current and complete. All products are sold subject to TI's terms and conditions of sale supplied at the time of order acknowledgment.

TI warrants performance of its hardware products to the specifications applicable at the time of sale in accordance with TI's standard warranty. Testing and other quality control techniques are used to the extent TI deems necessary to support this warranty. Except where mandated by government requirements, testing of all parameters of each product is not necessarily performed.

TI assumes no liability for applications assistance or customer product design. Customers are responsible for their products and applications using TI components. To minimize the risks associated with customer products and applications, customers should provide adequate design and operating safeguards.

TI does not warrant or represent that any license, either express or implied, is granted under any TI patent right, copyright, mask work right, or other TI intellectual property right relating to any combination, machine, or process in which TI products or services are used. Information published by TI regarding third-party products or services does not constitute a license from TI to use such products or services or a warranty or endorsement thereof. Use of such information may require a license from a third party under the patents or other intellectual property of the third party, or a license from TI under the patents or other intellectual property of TI.

Reproduction of information in TI data books or data sheets is permissible only if reproduction is without alteration and is accompanied by all associated warranties, conditions, limitations, and notices. Reproduction of this information with alteration is an unfair and deceptive business practice. TI is not responsible or liable for such altered documentation.

Resale of TI products or services with statements different from or beyond the parameters stated by TI for that product or service voids all express and any implied warranties for the associated TI product or service and is an unfair and deceptive business practice. TI is not responsible or liable for any such statements.

Following are URLs where you can obtain information on other Texas Instruments products and application solutions:

<b>Products</b>		<b>Applications</b>	
Amplifiers	<a href="http://amplifier.ti.com">amplifier.ti.com</a>	Audio	<a href="http://www.ti.com/audio">www.ti.com/audio</a>
Data Converters	<a href="http://dataconverter.ti.com">dataconverter.ti.com</a>	Automotive	<a href="http://www.ti.com/automotive">www.ti.com/automotive</a>
DSP	<a href="http://dsp.ti.com">dsp.ti.com</a>	Broadband	<a href="http://www.ti.com/broadband">www.ti.com/broadband</a>
Interface	<a href="http://interface.ti.com">interface.ti.com</a>	Digital Control	<a href="http://www.ti.com/digitalcontrol">www.ti.com/digitalcontrol</a>
Logic	<a href="http://logic.ti.com">logic.ti.com</a>	Military	<a href="http://www.ti.com/military">www.ti.com/military</a>
Power Mgmt	<a href="http://power.ti.com">power.ti.com</a>	Optical Networking	<a href="http://www.ti.com/opticalnetwork">www.ti.com/opticalnetwork</a>
Microcontrollers	<a href="http://microcontroller.ti.com">microcontroller.ti.com</a>	Security	<a href="http://www.ti.com/security">www.ti.com/security</a>
		Telephony	<a href="http://www.ti.com/telephony">www.ti.com/telephony</a>
		Video & Imaging	<a href="http://www.ti.com/video">www.ti.com/video</a>
		Wireless	<a href="http://www.ti.com/wireless">www.ti.com/wireless</a>

Mailing Address: Texas Instruments  
Post Office Box 655303 Dallas, Texas 75265