

承 认 书

APPROVAL SHEET

客户名称: _____
 Customer Name: _____

产品名称: 片式负温度系数热敏电阻器
 Product Name: CHIP NTC THERMISTOR

制造商料号: CMF系列
 Manufacturer P/N: _____

客户料号: _____
 Customer P/N: _____

版本号: A-2
 Version No.: _____

制造厂商 Manufacturer	
拟制 Draft	审核 Check
赵颖芳	徐雪枫
日期 Date	2014-1-16

客户承认印章 Approval Signet	
日期 Date	

地址: 广东省肇庆市风华路 18 号电子城
 Address: FENGHUA ELECTRONIC INDUSTRIAL CITY, 18th
 FENGHUA ROAD, ZHAOQING GUANGDONG, P. R. CHINA
 电话 Tel: 0758-6923615 传真 Fax: 0758-6923617
 电子邮件 E-mail: 2008lihuiqin@163.com
 网址 http://www.china-fenghua.com



【承认书样单号:】

承认书目录

Content

1、外形尺寸与内部结构	
Dimension & Inner-configuration 1
2、产品规格型号	
Product Spec. Model 2
3、电性能参数表	
Electrical Characteristics List 3~6
4、可靠性试验项目	
Reliability Testing Items 7~9
5、产品包装	
Packaging 10
6、推荐焊接条件	
Recommend Soldering Conditions 11~12
7、存储条件	
Storage Conditions 13
8、注意事项	
Note 13
9、样品反馈信息单	
Sample's feedback list 14

2、产品规格型号表示方法 Ordering Information

CMF X XXX X XXXX X X X X
 ① ② ③ ④ ⑤ ⑥ ⑦ ⑧ ⑨

① 产品代号：表示片式负温度系数热敏电阻

Product Code: Chip NTC Thermistor

② 尺寸规格代码

Size Code

代码/Code	D	A	B	C
尺寸 (英制) Size (Inches)	0402	0603	0805	1206

③ 标称电阻值 为 25℃时的零功率电阻，单位为 Ω ，
前二位为有效数字，第三位数字表示有效数字后“0”的个数。

Rated zero-power resistance(R_{25}) Unit: Ω

The first two are significant figure of resistance and the third one expresses number of following zeros.

④ 阻值公差代码 (%)

Tolerance of R_{25} (%)

代码/ Code	E	F	G	H	J	K	X
阻值公差 Tolerance of R_{25}	± 0.5	± 1.0	± 2.0	± 3.0	± 5.0	± 10.0	特殊公差

⑤ B 值常数,单位为 K

B value constant Unit:K

⑥ B 值精度代码(%)

Tolerance of B value(%)

代码/ Code	E	F	G	H	J	X
B 值公差 Tolerance of B value	± 0.5	± 1.0	± 2.0	± 3.0	± 5.0	特殊公差

⑦ B 值温度代码 (°C/°C)

B value Temperature Code

代码/ Code	A	B	C	D	E	F	G	H	M	N
T_1/T_2	25/50	25/ 85	0/25	0/50	0/100	0/80	25/100	-18/25	-20/25	5/25

⑧ 端电极材料代号：N—三层电极

Termination Code: N—Nickel Barrier

⑨ 包装方式代码：T—编带包装、B—散包装

Packaging style Code: T—Tape & Reel、B—Bulk

3、电性能参数表 Electrical Characteristics List

型号规格 Part Number	客户料号 Customer no.	R ₂₅ (KΩ)	B _{25/50} (k)
CMFD152□3200□ANT		1.5	3200
CMFD332□3450□ANT		3.3	3450
CMFD103□3500□ANT		10	3500
CMFD103□3900□ANT		10	3900
CMFD223□3600□ANT		22	3600
CMFD333□3300□ANT		33	3300
CMFD473□4050□ANT		47	4050
CMFD683□4100□ANT		68	4100
CMFD104□3900□ANT		100	3900
CMFD154□4150□ANT		150	4150

□ 表示阻值的误差 shows the resistance deviation (F 级±1%、G 级±2%、H 级±3%、J 级±5%、K 级±10%)
□ 表示 B 值的误差 shows the B-constant deviation (F 级±1%、G 级±2%、H 级±3%、J 级±5%、K 级±10%)

3、电性能参数表 Electrical Characteristics List

型号规格 Part Number	客户料号 Customer no.	R_{25} (KΩ)	$B_{25/50}$ (k)
CMFA102□3200□ANT		1.0	3200
CMFA222□3450□ANT		2.2	3450
CMFA472□3500□ANT		4.7	3500
CMFA502□3900□ANT		5.0	3900
CMFA682□3500□ANT		6.8	3500
CMFA103□3500□ANT		10	3500
CMFA103□3600□ANT		10	3600
CMFA103□3900□ANT		10	3900
CMFA153□3900□ANT		15	3900
CMFA223□3300□ANT		22	3300
CMFA333□4000□ANT		33	4000
CMFA473□4150□ANT		47	4150
CMFA503□4150□ANT		50	4150
CMFA683□3900□ANT		68	3900
CMFA104□4050□ANT		100	4050
CMFA224□4200□ANT		220	4200
CMFA304□4200□ANT		300	4200

表示阻值的误差 shows the resistance deviation (F级±1%、G级±2%、H级±3%、J级±5%、K级±10%)

表示 B 值的误差 shows the B-constant deviation (F级±1%、G级±2%、H级±3%、J级±5%、K级±10%)

3、电性能参数表 Electrical Characteristics List

型号规格 Part Number	客户料号 Customer no.	R ₂₅ (K Ω)	B _{25/50} (k)
CMFB102□3200□ANT		1.0	3200
CMFB152□3450□ANT		1.5	3450
CMFB222□3450□ANT		2.2	3450
CMFB472□3500□ANT		4.7	3500
CMFB103□3500□ANT		10	3500
CMFB103□3600□ANT		10	3600
CMFB103□3900□ANT		10	3900
CMFB153□3900□ANT		15	3900
CMFB223□3950□ANT		22	3950
CMFB303□3950□ANT		30	3950
CMFB333□4000□ANT		33	4000
CMFB473□4150□ANT		47	4150
CMFB683□3950□ANT		68	3950
CMFB104□4200□ANT		100	4200
CMFB224□4000□ANT		220	4000

□ 表示阻值的误差 shows the resistance deviation (F 级±1%、G 级±2%、H 级±3%、J 级±5%、K 级±10%)
□ 表示 B 值的误差 shows the B-constant deviation (F 级±1%、G 级±2%、H 级±3%、J 级±5%、K 级±10%)

3、电性能参数表 Electrical Characteristics List

型号规格 Part Number	客户料号 Customer no.	R_{25} (K Ω)	$B_{25/50}$ (k)
CMFC102□3200□ANT		1.0	3200
CMFC472□3500□ANT		4.7	3500
CMFC103□3500□ANT		10	3500
CMFC103□4000□ANT		10	4000
CMFC223□3300□ANT		22	3300
CMFC473□4050□ANT		47	4050
CMFC104□4200□ANT		100	4200

□ 表示阻值的误差 shows the resistance deviation (F 级±1%、G 级±2%、H 级±3%、J 级±5%、K 级±10%)

□ 表示 B 值的误差 shows the B-constant deviation (F 级±1%、G 级±2%、H 级±3%、J 级±5%、K 级±10%)

4、可靠性试验项目 Reliability Testing Items

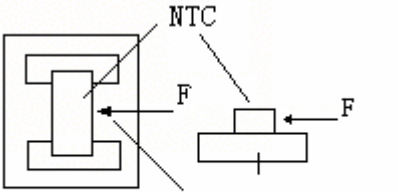
序号 NO.	项目 Item	标准 Standard	测试方法 Test Method															
1	工作温度范围 Operating Temperature Range	-40℃ ~ +120℃																
2	可焊 Solder ability	至少 90%端电极表面被焊锡覆盖。 At least 90% of terminal electrode should be covered with solder	预热温度: 100℃ ~ 150℃ 预热时间: 2 ~ 3Min. 焊锡温度: 255 ± 5℃ 浸锡时间: 5 ± 0.5s Preheating Temp. : 100℃ ~ 150℃ Preheating Time: 2 ~ 3min. Soldering Temp. : 255 ± 5℃ Immersion Time: 5 ± 0.5s															
3	耐焊接热 Resistance to Soldering	至少 75%的焊锡覆盖在端电极表面，无可见机械损伤。 R ₂₅ 变化率小于 ± 5% B 值 (B _{25/50}) 变化率小于 ± 2% At least 75% of terminal electrode should be covered with solder. No mechanical damage. R ₂₅ change shall be less than ± 5%; B-constant (B _{25/50}) change shall be less than ± 2%.	预热温度: 100℃ ~ 150℃ 预热时间: 2 ~ 3Min. 焊锡温度: 285 ± 5℃ 浸锡时间: 10 ± 0.5s Preheating Temp. : 100℃ ~ 150℃ Preheating Time: 2 ~ 3min. Soldering Temp. : 285 ± 5℃ Immersion Time: 10 ± 1s															
4	端电极强度 External Electrode Strength	瓷体及端头均不受破坏 Ceramic and termination shall not be damaged.	<div style="text-align: center;">  <p>环氧树脂印刷电路板 Epoxy PCB</p> <table border="1" style="margin-left: auto; margin-right: auto;"> <thead> <tr> <th style="width:15%;">类型 Type</th> <th style="width:25%;">推力 (N) Force (N)</th> <th style="width:20%;">时间 (s) Time (s)</th> </tr> </thead> <tbody> <tr> <td style="text-align: center;">0402</td> <td style="text-align: center;">10</td> <td style="text-align: center;">5 ± 1</td> </tr> <tr> <td style="text-align: center;">0603</td> <td style="text-align: center;">15</td> <td style="text-align: center;">5 ± 1</td> </tr> <tr> <td style="text-align: center;">0805</td> <td style="text-align: center;">20</td> <td style="text-align: center;">5 ± 1</td> </tr> <tr> <td style="text-align: center;">1206</td> <td style="text-align: center;">20</td> <td style="text-align: center;">5 ± 1</td> </tr> </tbody> </table> </div>	类型 Type	推力 (N) Force (N)	时间 (s) Time (s)	0402	10	5 ± 1	0603	15	5 ± 1	0805	20	5 ± 1	1206	20	5 ± 1
类型 Type	推力 (N) Force (N)	时间 (s) Time (s)																
0402	10	5 ± 1																
0603	15	5 ± 1																
0805	20	5 ± 1																
1206	20	5 ± 1																

4、可靠性试验项目 Reliability Testing Items

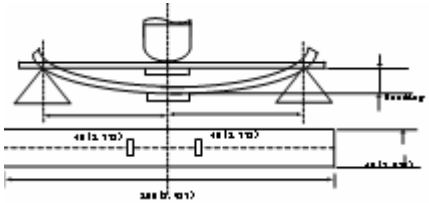
序号 NO.	项目 Item	标准 Standard	测试方法 Test Method						
5	振 动 Vibration	无可见机械损伤; R_{25} 变化率小于 $\pm 5\%$; B 值 ($B_{25/50}$) 变化率小于 $\pm 2\%$. Novisible mechanical damage ; R_{25} change shall be less than $\pm 5\%$; B -constant($B_{25/50}$)change shall be less than $\pm 2\%$.	振动频率范围:10 ~55Hz 全振幅: 1.52mm 时间:X\Y\Z 轴各 2hrs Frequency:10 ~55Hz Amplitude: 1.52mm Time: Vibrated for a period of 2hrs,in three directions perpendicularly intersecting each other.						
6	抗弯强度 Resistance to flexure	无可见机械损伤; R_{25} 变化率小于 $\pm 5\%$; B 值 ($B_{25/50}$) 变化率小于 $\pm 2\%$. No visible mechanical damage ; R_{25} change shall be less than $\pm 5\%$; B -constant($B_{25/50}$)change shall be less than $\pm 2\%$.	<div style="text-align: center;">  </div> <table border="1" style="margin: 10px auto; border-collapse: collapse;"> <thead> <tr> <th style="text-align: center;">规格 Size code</th> <th style="text-align: center;">弯曲度 h (mm) Camber (mm)</th> </tr> </thead> <tbody> <tr> <td style="text-align: center;">0402、0603</td> <td style="text-align: center;">0.7</td> </tr> <tr> <td style="text-align: center;">0805、1206</td> <td style="text-align: center;">1.0</td> </tr> </tbody> </table> <p>条件: 测试基板 (PCB) 施压速度: 0.5mm/s Condition: print circuit board. Pressing speed: 0.5 mm/s</p>	规格 Size code	弯曲度 h (mm) Camber (mm)	0402、0603	0.7	0805、1206	1.0
规格 Size code	弯曲度 h (mm) Camber (mm)								
0402、0603	0.7								
0805、1206	1.0								
7	跌落 Drop	无可见机械损伤; R_{25} 变化率小于 $\pm 5\%$; B 值 ($B_{25/50}$) 变化率小于 $\pm 2\%$. No visible mechanical damage; R_{25} change shall be less than $\pm 5\%$; B -constant($B_{25/50}$)change shall be less than $\pm 2\%$.	从高度为 1 米的空中自由落到混凝土地板, 重复 10 次 Drop 10 times on a concrete floor from a high of 1m.						
8	耐高温 Resistance to High Temperature	外观无可见损伤; R_{25} 变化率小于 $\pm 5\%$; B 值 ($B_{25/50}$) 变化率小于 $\pm 2\%$. No visible damage ; R_{25} change shall be less than $\pm 5\%$; B -constant($B_{25/50}$)change shall be less than $\pm 2\%$.	温度: $125 \pm 2^\circ\text{C}$ (无负荷) 试验时间: 500 ± 2 hrs Temp. : $125 \pm 2^\circ\text{C}$ (No Load) Time : 500 ± 2 hrs						

4、可靠性试验项目 Reliability Testing Items

序号 NO.	项目 Item	标准 Standard	测试方法 Test Method															
9	耐低温 Resistance to High Temperature	外观无可见机械损伤; R ₂₅ 变化率小于±5% B 值 (B _{25/50}) 变化率小于±2% No visible mechanical damage; R ₂₅ change shall be less than±5%; B-constant(B _{25/50})change shall be less than ±2%.	在-40±2℃的条件下放置 500±2hrs Temp. : -40±2℃ Time : 500±2hrs															
10	耐潮湿 Resistance to Humidity	外观无可见机械损伤; R ₂₅ 变化率小于±5%; B 值 (B _{25/50}) 变化率小于±2%. No visible mechanical damage; R ₂₅ change shall be less than±5%; B-constant(B _{25/50})change shall be less than ±2%.	在下列条件下放置 500±2hrs 温度: 55±2℃ 湿度: 90~95%RH Temp. : 55±2℃ Humidity : 90~95%RH Time : 500±2hrs															
11	温度循环 Temperature cycling	外观无可见损伤; R ₂₅ 变化率小于±5%; B 值 (B _{25/50}) 变化率小于±2% No visible damage ; R ₂₅ change shall be less than ±5%; B-constant(B _{25/50})change shall be less than ±2%.	无负荷, 在下列条件循环 5 次 cycles without load <table border="1"> <thead> <tr> <th>阶段 Step</th> <th>温度 Temp.</th> <th>时间 Time (Min.)</th> </tr> </thead> <tbody> <tr> <td>1</td> <td>-40℃</td> <td>30±3</td> </tr> <tr> <td>2</td> <td>室温/Room Temp</td> <td>10±2</td> </tr> <tr> <td>3</td> <td>+125℃</td> <td>30±3</td> </tr> <tr> <td>4</td> <td>室温/Room Temp</td> <td>10±2</td> </tr> </tbody> </table>	阶段 Step	温度 Temp.	时间 Time (Min.)	1	-40℃	30±3	2	室温/Room Temp	10±2	3	+125℃	30±3	4	室温/Room Temp	10±2
阶段 Step	温度 Temp.	时间 Time (Min.)																
1	-40℃	30±3																
2	室温/Room Temp	10±2																
3	+125℃	30±3																
4	室温/Room Temp	10±2																

5、产品包装 Packaging

5.1 外包装 Outer Package

5.1.1 包装 1: 数量 5 卷 Type 1:Box Quantity 5 reels

5.1.2 包装 2: 数量 12 盒 Type 2:Case Quantity 12 boxes

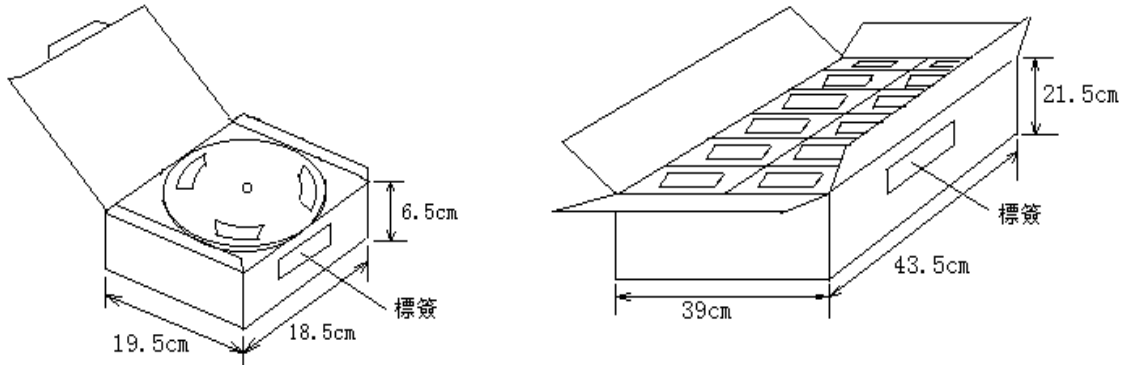

5.2 卷标及标识 Label and Mark

5.2.1 纸带胶盘上有卷标，包括以下内容 The label on reel should contain these information:

- | | | |
|----------------|--|-------------|
| ①型号规格 Part No. | ②标称电阻及 B 值 Nominal Resistance and B-constant | |
| ③数量 Quantity | ④误差范围 Tolerance | ⑤批号 Lot No. |
| ⑥日期 Date | ⑦QC 盖章 QC Stamper | |

5.2.2 包装盒或箱子标识以下内容

- | | | |
|----------------|--|-------------|
| ①型号规格 Part No. | ②标称电阻及 B 值 Nominal Resistance and B-constant | |
| ③数量 Quantity | ④误差范围 Tolerance | ⑤批号 Lot No. |
| ⑥日期 Date | ⑦QC 盖章 QC Stamper | |

6、推荐焊接条件 Recommend Soldering Conditions

6.1 焊接条件 Recommended Soldering Condition

6.1.1 回流焊 Re-flow soldering

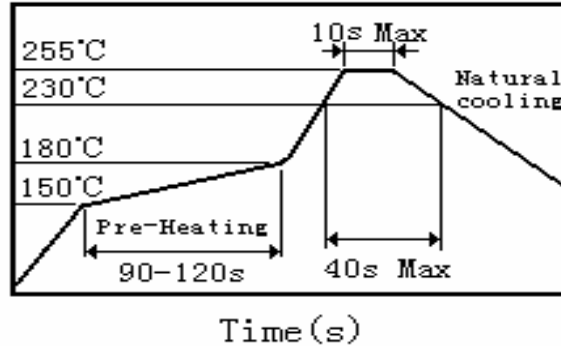

6.1.2 波峰焊 Wave soldering

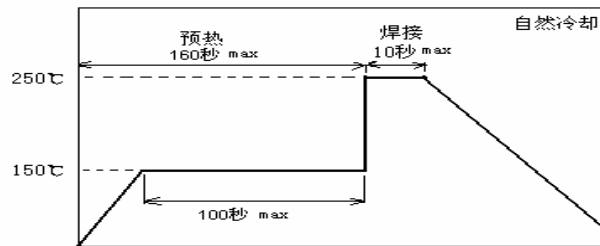

6.1.3 手工焊接 Iron soldering

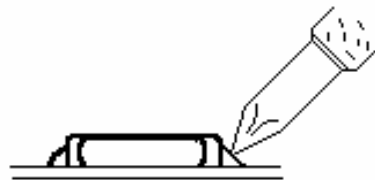

烙铁头温度: 350°C Max

Temp. of iron-tip: 350°C Max

烙铁功率: 30W Max

Iron wattage: 30W Max

烙铁停留时间: 5s Max

Soldering time: 5s sec Max

注意: 烙铁头不得与瓷体直接接触

Caution: Do not allow the iron-tip to directly touch the ceramic body.

6.1.4 助焊剂 Flux.

25%松香, 75%乙醇/25% Rosin, 75% Alcohol

6.1.5 清洗条件 Cleaning

清洗时间: 1分钟 Time: 1min

超声波功率: 最大为 200W/L Power of ultrasonic Cleaner: 200W/L Max.

6.1.6 使用温度范围: -40°C ~ +120°C

Temperature range: -40°C ~ +120°C

版本号 Version Number	A-2	页码 Page	12/14
-----------------------	-----	------------	-------

6、推荐焊接条件 Recommend Soldering Conditions

6.2 PC 板的设计

①当片式 NTCR 被安装在 PC 板上后，所使用的焊料的量（焊盘的大小）会直接影响到片式 NTCR 的性能，因此在设计基板时，必须慎重考虑焊盘的大小和配置，这些对组成基板的焊料的量有着决定的作用，过量的焊料会影响到芯片耐机械应力的能力。

②基板配置：将片式 NTCR 安装在板上之后，芯片将承受在下一加工过程中产生的机械应力，出于这个原因，在设计焊盘和片式 NTCR 的位置时，应注意考虑将应力减少到最低点。

6.3 自动安装应考虑到的问题

①在将片式 NTCR 安装在 PC 板上时，不能让其承受过量的冲击力。

②应定期对安装机器进行维护和检查。

③当 PC 板沿着接缝孔切割开时，片式 NTCR 所受机械应力的的大小因使用的方法不同而不同。以下方法按应力从小到大进行排列：推板、割裂、V 形凹槽、接缝孔。因此。任何理想的片式 NTCR 的布局必须考虑到 PC 板的分割方法。

6.4 焊膏的印刷

①焊膏的印刷厚度建议在 $150\mu\text{m}\sim 200\mu\text{m}$ 。

②焊接后，爬锡高度为 0.2mm 至本产品的厚度。

③过多的焊料将给本产品过大的机械应力，这些应力将导致断裂或机械损伤，也可能破坏产品的电性能。

6.5 粘合剂作用和处理

①在流体焊过程中，如果黏性不好或粘合剂不够坚硬，可能会导致产品和底板松散连接。

②黏胶的黏性太低将导致焊接后产品在板上滑动。

6.2 PCB design

① When chip thermistors are mounted on a PCB, the amount of solder used(size of fillet) can directly affect thermistor performance Therefore, when design land- patterns it is necessary to consider the appropriate size and configuration of the solder pads, which determines the amount of solder necessary to form the fillets. Excess solder can affect the ability of chips to withstand mechanical stress.

② Pattern configurations: After chip thermistor have been mounted on the board, chips can be subject to mechanical stresses in subsequent manufacturing process , for this reason, planning pattern configurations and the position of SMD thermistors should be carefully performed to minimize stress.

6.3 Considerations for automatic placement.

① Excessive impact load should not be imposed on the thermistor when mounting on the PCB .

② The maintenance and inspection of the mounting devices should be conducted periodically .

③ When beating PCB along their perforations, the amount of mechanical stress on the thermistor can vary according to the method used .The following methods are listed in order from least stressful to most stressful: push-back, slit, v-grooving, and perforation. Thus, any ideal SMD thermistor layout must also consider the PCB splitting procedure.

6.4 printing solder paste

① Recommendable thickness of solder paste printing should from $150\mu\text{m}$ to $200\mu\text{m}$.

② After soldering, the solder fillet shall be a height from 0.2mm to the thickness of chip thermistor.

③ Too much solder gives too strong mechanical stress to chip thermistor, such stress may cause cracking or any mechanical damage. And also, it can destroy the electrical performance of this product.

6.5 Adhesive Application and curing

① If insufficient adhesive is applied or if the adhesive is not sufficiently hardened this product may have a loose contact with the land, during flow soldering.

② Too low viscosity of adhesive causes chip thermistor to slip on board, after mounting.

版本号 Version Number	A-2	页码 Page	13/14
7、贮存条件 Storage Conditions		8、注意事项 Note	
<p>7、贮存条件</p> <p>①贮存条件：温度：-10~40℃ Temperature: -10℃ ~40℃</p> <p>②相对湿度：45~75% Humidity: 45~75% RH</p> <p>③保存期限：在交付六个月内使用本产品，如果超过六个月或更长时间，使用前请检查可焊性。 Storage Term: Use this product within 6 months after delivery. If 6 months or more elapsed, please check the solderability before use.</p> <p>④打开包装后的存放：拆包装后，迅速地重新封好或将产品放入有干燥剂的密封容器内。 Handling after unpacking: After unpacking, reseal promptly this product or store it in a sealed container with a drying agent.</p> <p>⑤贮存地点：存放在没有腐蚀性气体（SO_x、Cl 等）的地方；避免日光直接照射。 Storage place: store this product in no corrosive gas (SO_x, Cl, etc). Avoid direct sunlight.</p>			
<p>8、注意事项 Note</p> <p>8.1 本承认书保证我司产品作为一个单体时的质量情况，当我司产品被安装到贵公司产品上时请保证贵司的产品已根据贵司的规范进行了有效评价和确认。</p> <p>8.2 如果贵司对我司产品的试用已超过了本测试规范所界定的产品功能，对于此所引发的失效我司将不予保证。</p> <p>8.1 The recognition of the guarantee of our products as a single body quality, when our product is mounted to your product, please make sure that your product is according to your specifications are evaluated and confirmed.</p> <p>8.2 If your company on the Division I products trial has been more than the test specifications defined by the product features, for this triggered by the failure of Division I will not guarantee.</p>			

版本号 Version Number	A-2	页码 Page	14/14
-----------------------	-----	------------	-------

9、样品承认信息反馈单 Sample' s feedback list

尊敬的客户，您好！

感谢您对我公司的信任及支持，在我们合作的过程中，我们将尽最大努力满足您的各种需求，为您提供最满意的服务。

如果你在对我们的产品（样品）进行承认的过程中出现任何问题，请将问题反馈给我们，我们将对您提出的问题进行分析并在最短的时间内给您满意的答复及解决方案，在此过程中您只需填写这张信息反馈单并传真（邮寄）给我们即可。

预祝我们合作愉快！

Respect customer,

Thank you for your trust and support, In cooperation, we will do our best to meet your all of requests, and provide the best service to you.

If you have any problem, please feel free to contact us, we would earnestly analyze the question which you asked for, and reply to you as soon as possible. You only need fill in this form and fax or mail it to us.

Wishes cooperate happily!

以下是您对产品（样品）使用情况的简单描述 Problem Description

规格型号 Part NO.	
产品批号 LOT NO.	
送样日期 Sample Date	
出现问题 Problem description	
您的分析（原因） Your analysis (for the reason)	
备注 Note	

您的联系方式（便于我们的交流） Your contact

您的姓名 Your Name		公司名称 Company	
职务 Business		地址 Address	
电话 Tel		邮编 Post	
传真 Fax		E-mail	

联系我们 Contact us

联系人 Contact person	李惠琴 Li huiqin	电话 Tel	0758-6923615
传真 Fax	0758-6923617	E-mail	2008lihuiqin@163.com
邮编 Post	526020	地址 Address	广东省肇庆市风华路 18 号风华电子工业城 Fenghua Electronic Industrial City,18th Fenghua Road, Zhaoqing Guangdong, P.R, China
备注 Note	为了我们更好的合作，请您及时填写并回传。 Please fill in the form and feedback to us in time, thanks!		