

TC74HC4049P/F
TC74HC4050P/F

T-43-21

TC74HC4049 P/ F HEX BUFFER/CONVERTER (INVERTING)
TC74HC4050 P/ F HEX BUFFER CONVERTER

The TC74HC4049 and the TC74HC4050 are high speed CMOS HEX BUFFER fabricated with silicon gate CMOS technology. It achieves the high speed operation similar to equivalent LSTTL while maintaining the CMOS low power dissipation. The TC74HC4049 is an inverting buffer, while the TC74HC4050 is a non-inverting buffer. The internal circuit is composed of 3-stage or 2-stage inverters, which enables high noise immunity and stable output. Input protection circuits are different from those of the high speed CMOS IC's. They eliminate diodes of V_{CC} side and enable logic-level conversion from high-level voltage (up to 15V) to low-level voltage. These IC's are useful for battery back up circuits, because input voltage can be applied on IC's which is not biased by V_{CC}.

FEATURES:

- . High Speed.....t_{pd}=10ns(Typ.) at V_{CC}=5V
- . Low Power Dissipation.....I_{CC}=1μA(Max.) at Ta=25°C
- . High Noise Immunity.....V_{NIH}=V_{NIL}=28% V_{CC}(Min.)
- . Output Drive Capability.....15 LSTTL Loads
- . Symmetrical Output Impedance..|I_{OH}|=I_{OL}=6mA(Min.)
- . Balanced Propagation Delays...t_{pLH}≐t_{pHL}
- . Wide Operating Voltage Range..V_{CC(opr)}=2V~6V
- . Pin and Function Compatible with 4049B, 4050B.

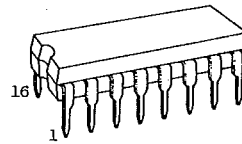

DIP16(3D16A-P)

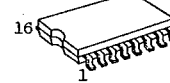

MFP16(F16GC-P)

PIN ASSIGNMENT

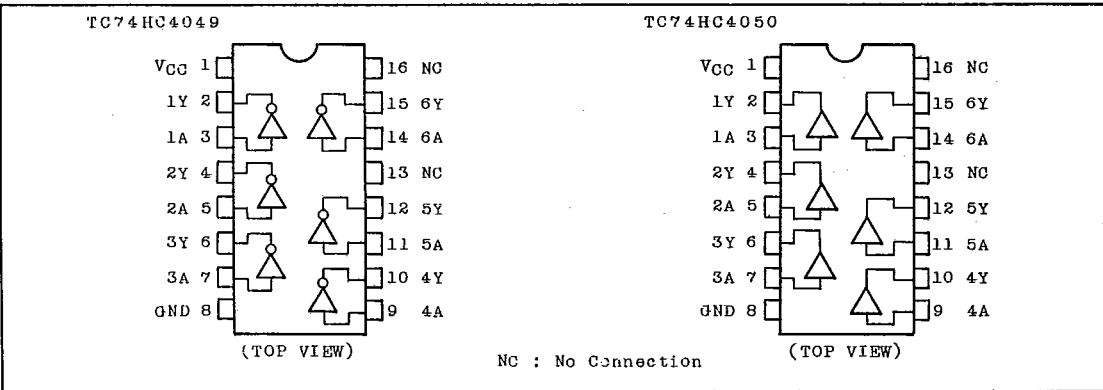

TC74HC4049P/F
TC74HC4050P/F

T-43-21

CIRCUIT SCHEMATIC (per Gate)

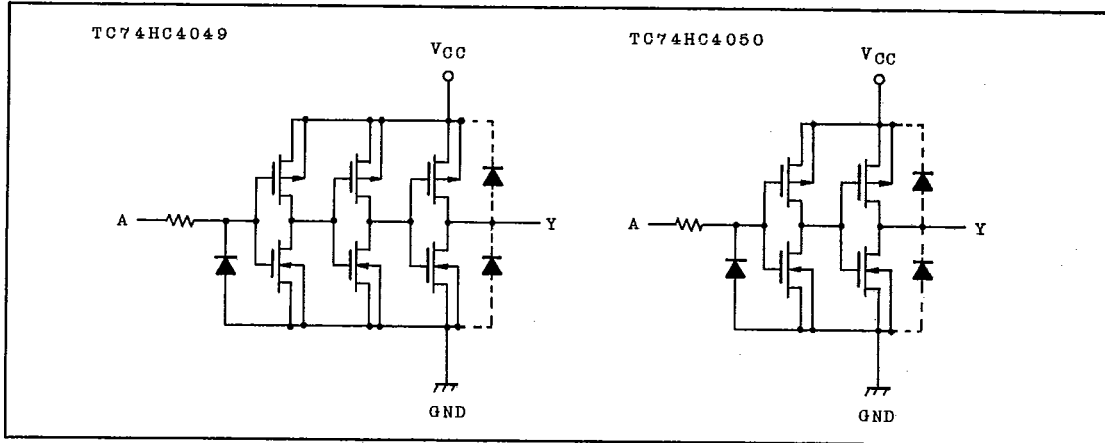

ABSOLUTE MAXIMUM RATINGS

PARAMETER	SYMBOL	VALUE	UNIT
Supply Voltage Range	V _{CC}	-0.5 ~ 7	V
DC Input Voltage	V _{IN}	-0.5 ~ 18*	V
DC Output Voltage	V _{OUT}	-0.5 ~ V _{CC} +0.5	V
Input Diode Current	I _{IK}	-20	mA
Output Diode Current	I _{OK}	±20	mA
DC Output Current	I _{OUT}	±35	mA
DC V _{CC} /Ground Current	I _{CC}	±70	mA
Power Dissipation	P _D	500(DIP)**/180(MFP)	mW
Storage Temperature	T _{stg}	-65 ~ 150	°C
Lead Temperature 10sec	T _L	300	°C

Note.

*DC input voltage is able to impress -0.5V to 18V based on GND without any relation to voltage of V_{CC}. Recommended operating condition is from 0V to 15V and it is possible to convert logic-level from 15V to 5V or 5V to 2V.

**500mW in the range of T_a = -40°C ~ 65°C and from T_a = 65°C up to 85°C derating factor of -10mW/°C shall be applied until 300mW.

RECOMMENDED OPERATING CONDITIONS

PARAMETER	SYMBOL	LIMIT	UNIT
Supply Voltage	V _{CC}	2 ~ 6	V
Input Voltage	V _{IN}	0 ~ 15	V
Output Voltage	V _{OUT}	0 ~ V _{CC}	V
Operating Temperature	T _{opr}	-40 ~ 85	°C
Input Rise and Fall Time	t _r , t _f	0 ~ 1000 (V _{CC} =2.0V) 0 ~ 500 (V _{CC} =4.5V) 0 ~ 400 (V _{CC} =6.0V)	ns

TC74HC4049P/F
TC74HC4050P/F

T-43-21

DC ELECTRICAL CHARACTERISTICS

PARAMETER	SYMBOL	TEST CONDITION	Ta=25°C			Ta=-40~85°C		UNIT		
			V _{CC}	MIN.	TYP.	MAX.	MIN.		MAX.	
High-Level Input Voltage	V _{IH}		2.0	1.5	-	-	1.5	-	V	
			4.5	3.15	-	-	3.15	-		
			6.0	4.2	-	-	4.2	-		
Low-Level Input Voltage	V _{IL}		2.0	-	-	0.5	-	0.5	V	
			4.5	-	-	1.35	-	1.35		
			6.0	-	-	1.8	-	1.8		
High-Level Output Voltage	V _{OH}	V _{IN} = V _{IH} or V _{IL}	I _{OH} =-20μA	2.0	1.9	2.0	-	1.9	-	V
				4.5	4.4	4.5	-	4.4	-	
		I _{OH} =-6mA I _{OH} =-7.8mA	4.5	4.18	4.31	-	4.13	-		
			6.0	5.68	5.80	-	5.63	-		
Low-Level Output Voltage	V _{OL}	V _{IN} = V _{IH} or V _{IL}	I _{OL} =20μA	2.0	-	0.0	0.1	-	0.1	V
				4.5	-	0.0	0.1	-	0.1	
		I _{OL} =6mA I _{OL} =7.8mA	4.5	-	0.17	0.26	-	0.33		
			6.0	-	0.18	0.26	-	0.33		
Input Leakage Current	I _{IN}	V _{IN} =V _{CC} or GND	6.0	-	-	±0.1	-	±1.0	μA	
Quiescent Supply Current	I _{CC}	V _{IN} =V _{CC} or GND	6.0	-	-	1.0	-	10.0		

TC74HC4049P/F
TC74HC4050P/F

T-43-21

AC ELECTRICAL CHARACTERISTICS (C_L=50pF, Input t_r=t_f=6ns)

PARAMETER	SYMBOL	TEST CONDITION	Ta=25°C			Ta=-40~85°C		UNIT	
			V _{CC}	MIN.	TYP.	MAX.	MIN.		MAX.
Output Transition Time	t _{TLH}		2.0	-	25	60	-	75	ns
	t _{THL}		4.5	-	6	12	-	15	
			6.0	-	5	10	-	13	
Propagation Delay Time	t _{pLH}		2.0	-	48	100	-	125	ns
	t _{pHL}		4.5	-	12	20	-	25	
			6.0	-	10	17	-	21	
Input Capacitance	C _{IN}		-	5	10	-	10	pF	
Power Dissipation Capacitance	C _{PD} (1)		-	25	-	-	-		

Note (1) C_{PD} is defined as the value of internal equivalent capacitance of IC which is calculated from the operating current consumption without load (refer to Test Circuit).

Average operating current can be obtained by the equation hereunder.

$$I_{CC(opr)} = C_{PD} \cdot V_{CC} \cdot f_{IN} + I_{CC}/6 \text{ (per Gate)}$$

SWITCHING CHARACTERISTICS TEST CIRCUIT

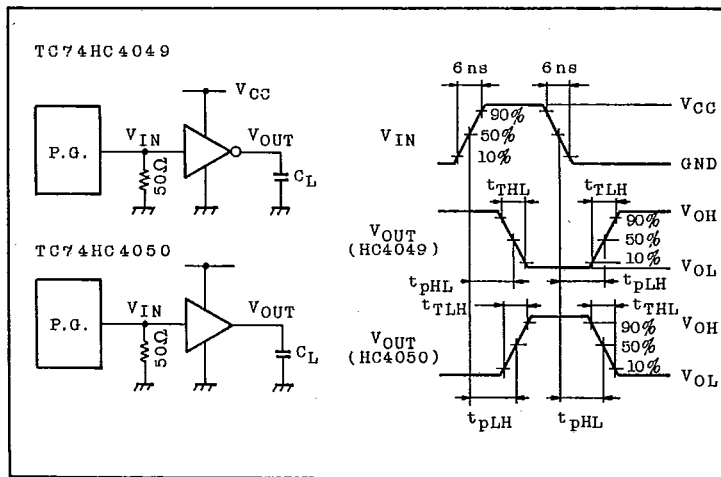

I_{CC(opr)} TEST CIRCUIT

