

Fractional-N Clock Multiplier with Internal LCO

Features

- ◆ Clock Multiplier / Jitter Reduction
 - Generates a Low Jitter 6 - 75 MHz Clock from a Jittery or Intermittent 50 Hz to 30 MHz Clock Source
- ◆ Internal LC Oscillator for Timing Reference
- ◆ Highly Accurate PLL Multiplication Factor
 - Maximum Error less than 1 PPM in High-Resolution Mode
- ◆ I²C / SPI™ Control Port
- ◆ Configurable Auxiliary Output
- ◆ Minimal Board Space Required
 - No External Analog Loop-filter Components

General Description

The CS2300-CP is an extremely versatile system clocking device that utilizes a programmable phase lock loop. The CS2300-CP is based on a hybrid analog-digital PLL architecture comprised of a unique combination of a Delta-Sigma Fractional-N Frequency Synthesizer and a Digital PLL. This architecture allows for generation of a low-jitter clock relative to an external noisy synchronization clock at frequencies as low as 50 Hz. The CS2300-CP supports both I²C and SPI for full software control.

The CS2300-CP is available in a 10-pin MSOP package in Commercial (-10°C to +70°C) and Automotive-D (-40°C to +85°C) and Automotive-E (-40°C to +105°C) grades. Customer development kits are also available for device evaluation. Please see [“Ordering Information” on page 31](#) for complete details.

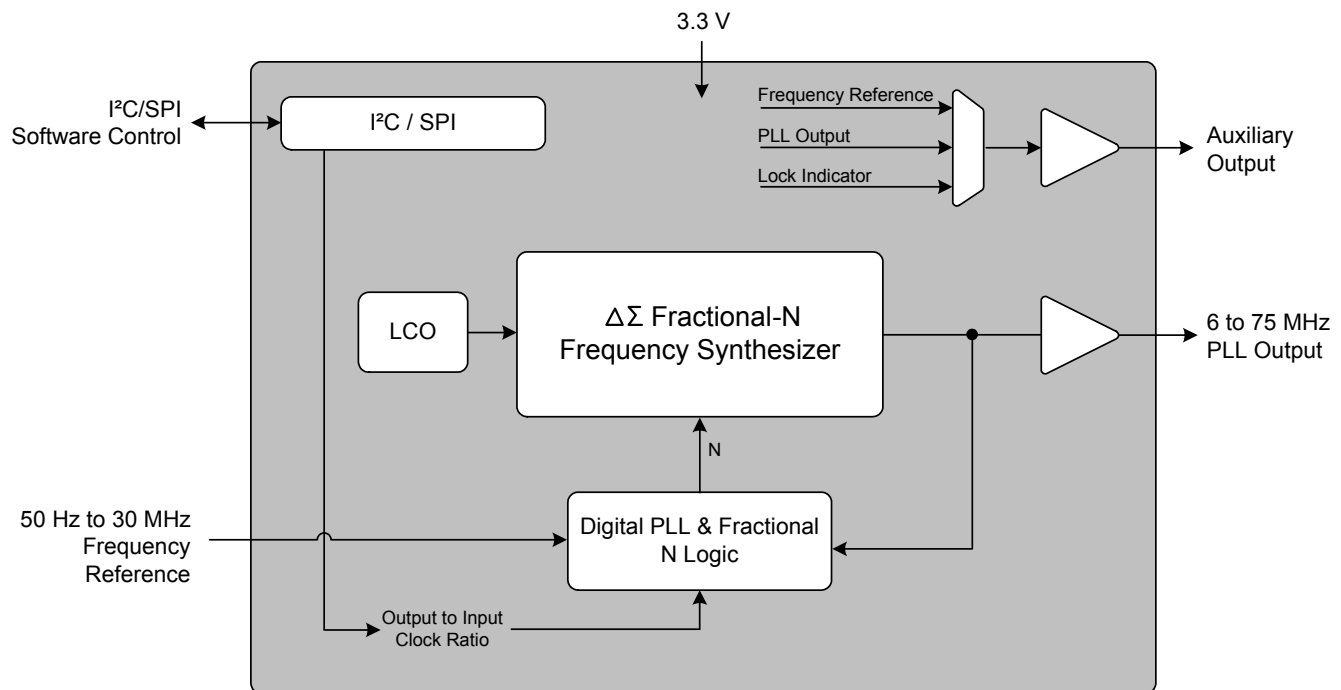

TABLE OF CONTENTS

1. PIN DESCRIPTION	5
2. TYPICAL CONNECTION DIAGRAM	6
3. CHARACTERISTICS AND SPECIFICATIONS	7
RECOMMENDED OPERATING CONDITIONS	7
ABSOLUTE MAXIMUM RATINGS	7
DC ELECTRICAL CHARACTERISTICS	7
AC ELECTRICAL CHARACTERISTICS	8
PLL PERFORMANCE PLOTS	9
CONTROL PORT SWITCHING CHARACTERISTICS- I ² C FORMAT	10
CONTROL PORT SWITCHING CHARACTERISTICS - SPI FORMAT	11
4. ARCHITECTURE OVERVIEW	12
4.1 Delta-Sigma Fractional-N Frequency Synthesizer	12
4.2 Hybrid Analog-Digital Phase Locked Loop	12
5. APPLICATIONS	14
5.1 Timing Reference Clock	14
5.2 Frequency Reference Clock Input, CLK_IN	14
5.2.1 CLK_IN Skipping Mode	14
5.2.2 Adjusting the Minimum Loop Bandwidth for CLK_IN	16
5.3 Output to Input Frequency Ratio Configuration	17
5.3.1 User Defined Ratio (RUD)	17
5.3.2 Ratio Modifier (R-Mod)	18
5.3.3 Effective Ratio (REFF)	18
5.3.4 Ratio Configuration Summary	19
5.4 PLL Clock Output	20
5.5 Auxiliary Output	20
5.6 Clock Output Stability Considerations	21
5.6.1 Output Switching	21
5.6.2 PLL Unlock Conditions	21
5.7 Required Power Up Sequencing	21
6. SPI / I²C CONTROL PORT	21
6.1 SPI Control	22
6.2 I ² C Control	22
6.3 Memory Address Pointer	24
6.3.1 Map Auto Increment	24
7. REGISTER QUICK REFERENCE	24
8. REGISTER DESCRIPTIONS	25
8.1 Device I.D. and Revision (Address 01h)	25
8.1.1 Device Identification (Device[4:0]) - Read Only	25
8.1.2 Device Revision (Revision[2:0]) - Read Only	25
8.2 Device Control (Address 02h)	25
8.2.1 Unlock Indicator (Unlock) - Read Only	25
8.2.2 Auxiliary Output Disable (AuxOutDis)	25
8.2.3 PLL Clock Output Disable (ClkOutDis)	26
8.3 Device Configuration 1 (Address 03h)	26
8.3.1 R-Mod Selection (RModSel[2:0])	26
8.3.2 Auxiliary Output Source Selection (AuxOutSrc[1:0])	26
8.3.3 Enable Device Configuration Registers 1 (EnDevCfg1)	27
8.4 Global Configuration (Address 05h)	27
8.4.1 Device Configuration Freeze (Freeze)	27
8.4.2 Enable Device Configuration Registers 2 (EnDevCfg2)	27
8.5 Ratio (Address 06h - 09h)	27
8.6 Function Configuration 1 (Address 16h)	28

8.6.1 Clock Skip Enable (ClkSkipEn)	28
8.6.2 AUX PLL Lock Output Configuration (AuxLockCfg)	28
8.6.3 Enable Device Configuration Registers 3 (EnDevCfg3)	28
8.7 Function Configuration 2 (Address 17h)	29
8.7.1 Enable PLL Clock Output on Unlock (ClkOutUnl)	29
8.7.2 Low-Frequency Ratio Configuration (LFRatioCfg)	29
8.8 Function Configuration 3 (Address 1Eh)	29
8.8.1 Clock Input Bandwidth (ClkIn_BW[2:0])	29
9. CALCULATING THE USER DEFINED RATIO	30
9.1 High Resolution 12.20 Format	30
9.2 High Multiplication 20.12 Format	30
10. PACKAGE DIMENSIONS	31
THERMAL CHARACTERISTICS	31
11. ORDERING INFORMATION	32
12. REFERENCES	32
13. REVISION HISTORY	32

LIST OF FIGURES

Figure 1. Typical Connection Diagram	6
Figure 2. CLK_IN Sinusoidal Jitter Tolerance	9
Figure 3. CLK_IN Sinusoidal Jitter Transfer	9
Figure 4. CLK_IN Random Jitter Rejection and Tolerance	9
Figure 5. Control Port Timing - I ² C Format	10
Figure 6. Control Port Timing - SPI Format (Write Only)	11
Figure 7. Delta-Sigma Fractional-N Frequency Synthesizer	12
Figure 8. Hybrid Analog-Digital PLL	13
Figure 9. External Component Requirements for LCO	14
Figure 10. CLK_IN removed for > 2 ²³ LCO cycles	15
Figure 11. CLK_IN removed for < 2 ²³ LCO cycles but > t _{CS}	15
Figure 12. CLK_IN removed for < t _{CS}	16
Figure 13. Low bandwidth and new clock domain	17
Figure 14. High bandwidth with CLK_IN domain re-use	17
Figure 15. Ratio Feature Summary	19
Figure 16. PLL Clock Output Options	20
Figure 17. Auxiliary Output Selection	20
Figure 18. Control Port Timing in SPI Mode	22
Figure 19. Control Port Timing, I ² C Write	23
Figure 20. Control Port Timing, I ² C Aborted Write + Read	23

LIST OF TABLES

Table 1. Ratio Modifier	18
Table 2. Example 12.20 R-Values	30
Table 3. Example 20.12 R-Values	30

1. PIN DESCRIPTION

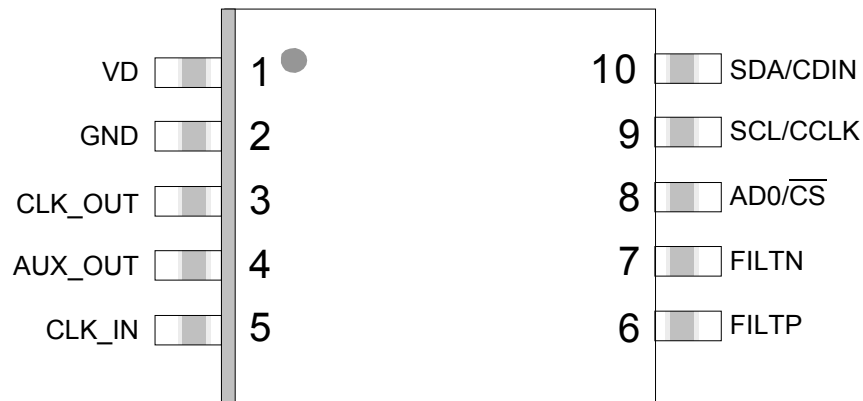

Pin Name	#	Pin Description
VD	1	Digital Power (Input) - Positive power supply for the digital and analog sections.
GND	2	Ground (Input) - Ground reference.
CLK_OUT	3	PLL Clock Output (Output) - PLL clock output.
AUX_OUT	4	Auxiliary Output (Output) - This pin outputs a buffered version of one of the input or output clocks, or a status signal, depending on register configuration.
CLK_IN	5	Frequency Reference Clock Input (Input) - Clock input for the Digital PLL frequency reference.
FILTP FILTN	6 7	LCO Filter Connections (Input/Output) - These pins provide external supply filtering for the internal LC Oscillator.
AD0/ $\overline{\text{CS}}$	8	Address Bit 0 (I²C) / Control Port Chip Select (SPI) (Input) - AD0 is a chip address pin in I ² C Mode. $\overline{\text{CS}}$ is the chip select signal in SPI Mode.
SCL/CCLK	9	Control Port Clock (Input) - SCL/CCLK is the serial clock for the serial control port in I ² C and SPI mode.
SDA/CDIN	10	Serial Control Data (Input/Output) - SDA is the data I/O line in I ² C Mode. CDIN is the input data line for the control port interface in SPI Mode.

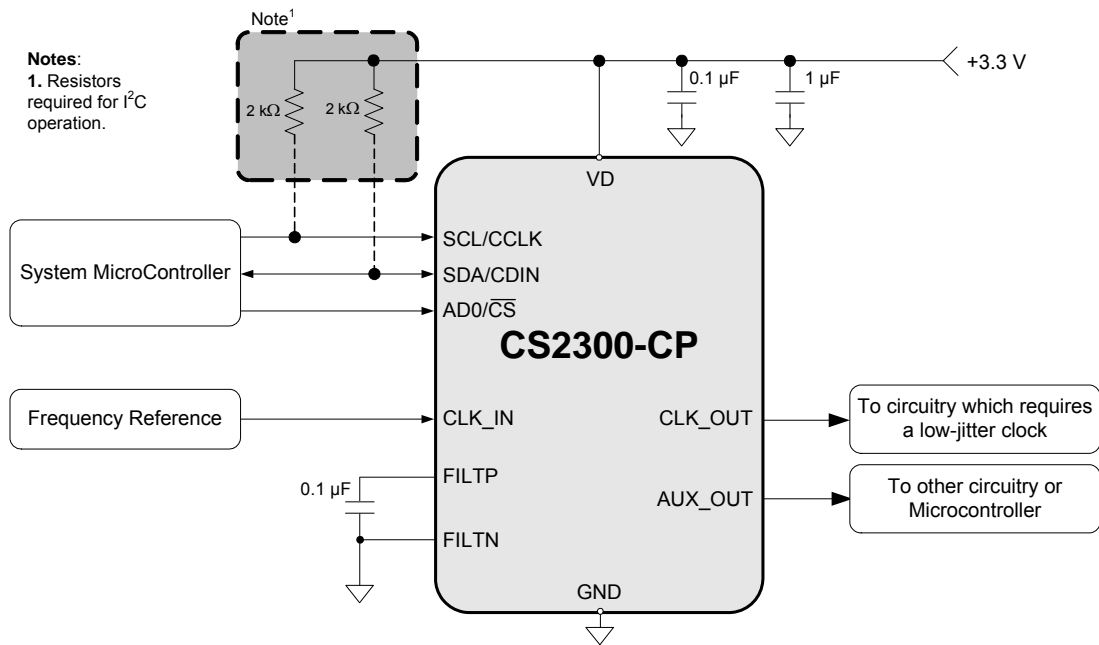
2. TYPICAL CONNECTION DIAGRAM

Figure 1. Typical Connection Diagram

3. CHARACTERISTICS AND SPECIFICATIONS

RECOMMENDED OPERATING CONDITIONS

GND = 0 V; all voltages with respect to ground. (Note 1)

Parameters	Symbol	Min	Typ	Max	Units
DC Power Supply	VD	3.1	3.3	3.5	V
Ambient Operating Temperature (Power Applied)					
Commercial Grade	T _{AC}	-10	-	+70	°C
Automotive Grade	T _{AD}	-40	-	+85	°C

Notes: 1. Device functionality is not guaranteed or implied outside of these limits. Operation outside of these limits may adversely affect device reliability.

ABSOLUTE MAXIMUM RATINGS

GND = 0 V; all voltages with respect to ground.

Parameters	Symbol	Min	Max	Units
DC Power Supply	VD	-0.3	6.0	V
Input Current	I _{IN}	-	±10	mA
Digital Input Voltage (Note 2)	V _{IN}	-0.3	VD + 0.4	V
Ambient Operating Temperature (Power Applied)	T _A	-55	125	°C
Storage Temperature	T _{stg}	-65	150	°C

WARNING: Operation at or beyond these limits may result in permanent damage to the device.

Notes: 2. The maximum over/under voltage is limited by the input current except on the power supply pin.

DC ELECTRICAL CHARACTERISTICS

Test Conditions (unless otherwise specified): VD = 3.1 V to 3.5 V; T_A = -10°C to +70°C (Commercial Grade); T_A = -40°C to +85°C (Automotive-D Grade); T_A = -40°C to +105°C (Automotive-E Grade).

Parameters	Symbol	Min	Typ	Max	Units
Power Supply Current - Unloaded (Note 3)	I _D	-	18	23	mA
Power Dissipation - Unloaded (Note 3)	P _D	-	59	76	mW
Input Leakage Current	I _{IN}	-	-	±10	µA
Input Capacitance	I _C	-	8	-	pF
High-Level Input Voltage	V _{IH}	70%	-	-	VD
Low-Level Input Voltage	V _{IL}	-	-	30%	VD
High-Level Output Voltage (I _{OH} = -1.2 mA)	V _{OH}	80%	-	-	VD
Low-Level Output Voltage (I _{OH} = 1.2 mA)	V _{OL}	-	-	20%	VD

Notes: 3. To calculate the additional current consumption due to loading (per output pin), multiply clock output frequency by load capacitance and power supply voltage.

For example, f_{CLK_OUT} (49.152 MHz) * C_L (15 pF) * VD (3.3 V) = 2.4 mA of additional current due to these loading conditions on CLK_OUT.

AC ELECTRICAL CHARACTERISTICS

Test Conditions (unless otherwise specified): $V_D = 3.1\text{ V to }3.5\text{ V}$; $T_A = -10^\circ\text{C to }+70^\circ\text{C}$ (Commercial Grade); $T_A = -40^\circ\text{C to }+85^\circ\text{C}$ (Automotive-D Grade); $T_A = -40^\circ\text{C to }+105^\circ\text{C}$ (Automotive-E Grade); $C_L = 15\text{ pF}$.

Parameters	Symbol	Conditions	Min	Typ	Max	Units
Clock Input Frequency	$f_{\text{CLK_IN}}$		50 Hz	-	30	MHz
Clock Input Pulse Width	$\text{PW}_{\text{CLK_IN}}$	$f_{\text{CLK_IN}} < 175\text{ kHz}$ $f_{\text{CLK_IN}} > 175\text{ kHz}$	140 10	- -	- -	ns ns
Clock Skipping Timeout	t_{CS}	(Notes 4, 5)	20	-	-	ms
Clock Skipping Input Frequency	$f_{\text{CLK_SKIP}}$	(Note 5)	50 Hz	-	80	kHz
PLL Clock Output Frequency	$f_{\text{CLK_OUT}}$	(Note 6)	6	-	75	MHz
PLL Clock Output Duty Cycle	t_{OD}	Measured at $V_D/2$	45	50	55	%
Clock Output Rise Time	t_{OR}	20% to 80% of V_D	-	1.7	3.0	ns
Clock Output Fall Time	t_{OF}	80% to 20% of V_D	-	1.7	3.0	ns
Period Jitter	t_{JIT}	(Note 7)	-	35	-	ps rms
Base Band Jitter (100 Hz to 40 kHz)		(Notes 7, 8)	-	50	-	ps rms
Wide Band Jitter (100 Hz Corner)		(Notes 7, 9)	-	150	-	ps rms
PLL Lock Time - CLK_IN (Note 10)	t_{LC}	$f_{\text{CLK_IN}} < 200\text{ kHz}$ $f_{\text{CLK_IN}} > 200\text{ kHz}$	- -	100 1	200 3	UI ms

- Notes:**
- t_{CS} represents the time from the removal of CLK_IN by which CLK_IN must be re-applied to ensure that PLL_OUT continues while the PLL re-acquires lock. This timeout is based on the internal VCO frequency, with the minimum timeout occurring at the maximum VCO frequency. Lower VCO frequencies will result in larger values of t_{CS} .
 - Only valid in clock skipping mode; See “CLK_IN Skipping Mode” on page 13 for more information.
 - $f_{\text{CLK_OUT}}$ is ratio-limited when $f_{\text{CLK_IN}}$ is below 72 Hz.
 - $f_{\text{CLK_OUT}} = 24.576\text{ MHz}$; Sample size = 10,000 points; $\text{AuxOutSrc}[1:0] = 11$.
 - In accordance with AES-12id-2006 section 3.4.2. Measurements are Time Interval Error taken with 3rd order 100 Hz to 40 kHz bandpass filter.
 - In accordance with AES-12id-2006 section 3.4.1. Measurements are Time Interval Error taken with 3rd order 100 Hz Highpass filter.
 - 1 UI (unit interval) corresponds to $t_{\text{CLK_IN}}$ or $1/f_{\text{CLK_IN}}$.

PLL PERFORMANCE PLOTS

Test Conditions (unless otherwise specified): $V_D = 3.3\text{ V}$; $T_A = 25\text{ }^\circ\text{C}$; $C_L = 15\text{ pF}$; $f_{\text{CLK_OUT}} = 12.288\text{ MHz}$;
 $f_{\text{CLK_IN}} = 12.288\text{ MHz}$; Sample size = 10,000 points; Base Band Jitter (100 Hz to 40 kHz); $\text{AuxOutSrc}[1:0] = 11$.

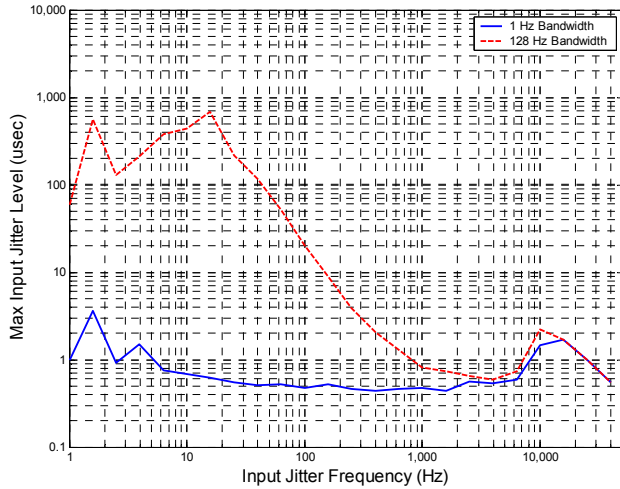

Figure 2. CLK_IN Sinusoidal Jitter Tolerance

Samples size = 2.5M points; Base Band Jitter (100Hz to 40kHz).

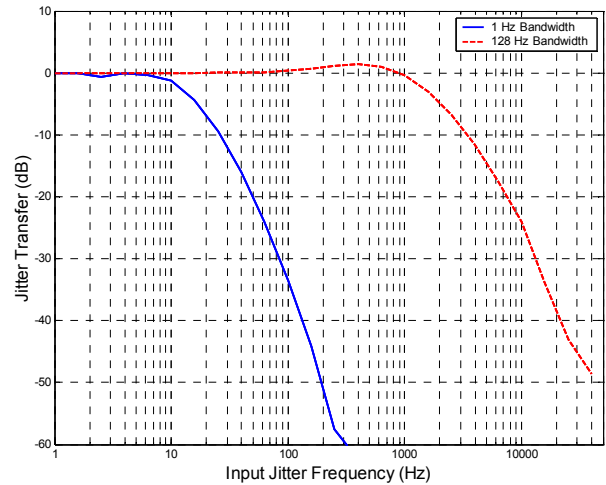

Figure 3. CLK_IN Sinusoidal Jitter Transfer

Samples size = 2.5M points; Base Band Jitter (100Hz to 40kHz).

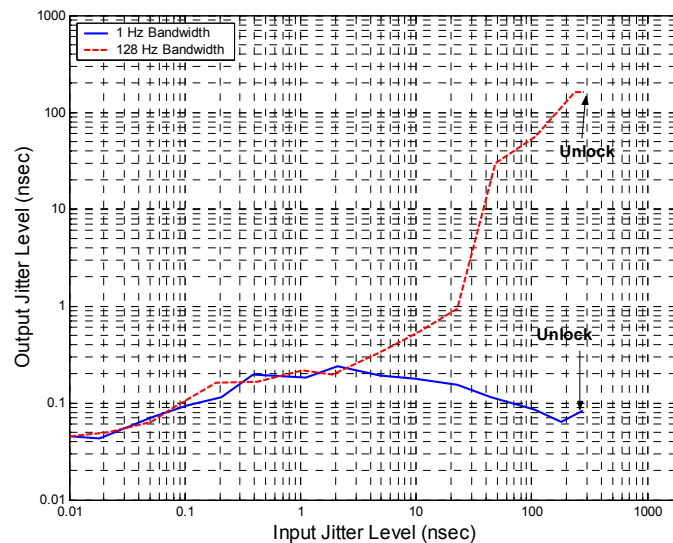

Figure 4. CLK_IN Random Jitter Rejection and Tolerance

CONTROL PORT SWITCHING CHARACTERISTICS- I²C FORMAT

Inputs: Logic 0 = GND; Logic 1 = VD; C_L = 20 pF.

Parameter	Symbol	Min	Max	Unit
SCL Clock Frequency	f _{scl}	-	100	kHz
Bus Free-Time Between Transmissions	t _{buf}	4.7	-	μs
Start Condition Hold Time (prior to first clock pulse)	t _{hdst}	4.0	-	μs
Clock Low Time	t _{low}	4.7	-	μs
Clock High Time	t _{high}	4.0	-	μs
Setup Time for Repeated Start Condition	t _{sust}	4.7	-	μs
SDA Hold Time from SCL Falling (Note 11)	t _{hdd}	0	-	μs
SDA Setup Time to SCL Rising	t _{sud}	250	-	ns
Rise Time of SCL and SDA	t _r	-	1	μs
Fall Time SCL and SDA	t _f	-	300	ns
Setup Time for Stop Condition	t _{susp}	4.7	-	μs
Acknowledge Delay from SCL Falling	t _{ack}	300	1000	ns
Delay from Supply Voltage Stable to Control Port Ready	t _{dpor}	100	-	μs

Notes: 11. Data must be held for sufficient time to bridge the transition time, t_f, of SCL.

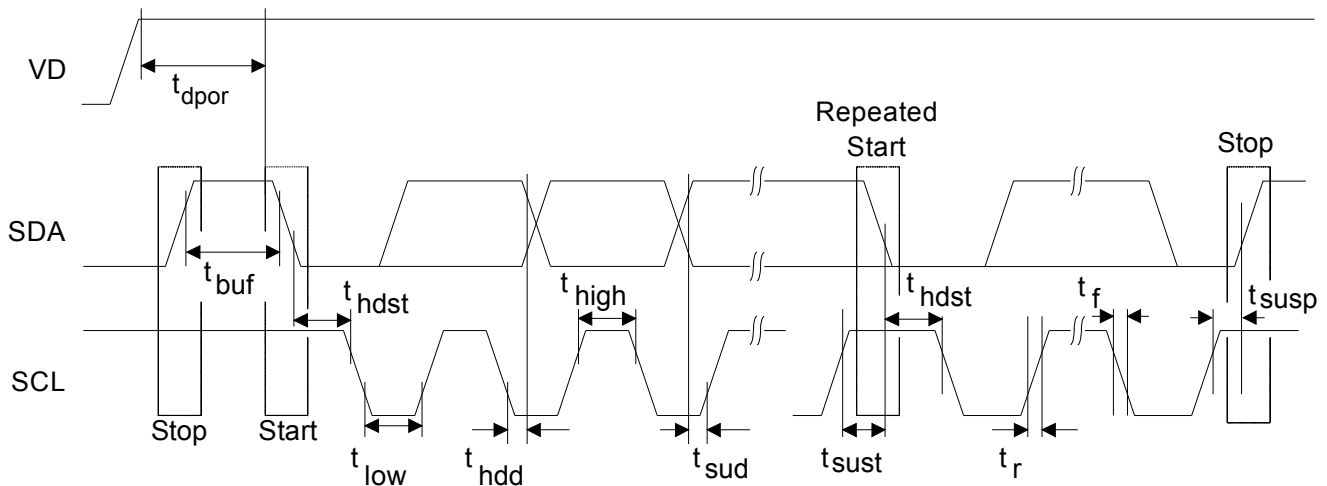

Figure 5. Control Port Timing - I²C Format

CONTROL PORT SWITCHING CHARACTERISTICS - SPI FORMAT

Inputs: Logic 0 = GND; Logic 1 = VD; $C_L = 20$ pF.

Parameter	Symbol	Min	Max	Unit
CCLK Clock Frequency	f_{cclk}	-	6	MHz
CCLK Edge to \overline{CS} Falling (Note 12)	t_{spi}	500	-	ns
\overline{CS} High Time Between Transmissions	t_{csh}	1.0	-	μ s
\overline{CS} Falling to CCLK Edge	t_{css}	20	-	ns
CCLK Low Time	t_{scl}	66	-	ns
CCLK High Time	t_{sch}	66	-	ns
CDIN to CCLK Rising Setup Time	t_{dsu}	40	-	ns
CCLK Rising to DATA Hold Time (Note 13)	t_{dh}	15	-	ns
Rise Time of CCLK and CDIN (Note 14)	t_{r2}	-	100	ns
Fall Time of CCLK and CDIN (Note 14)	t_{f2}	-	100	ns
Delay from Supply Voltage Stable to Control Port Ready	t_{dpor}	100	-	μ s

- Notes:** 12. t_{spi} is only needed before first falling edge of \overline{CS} after power is applied. $t_{spi} = 0$ at all other times.
 13. Data must be held for sufficient time to bridge the transition time of CCLK.
 14. For $f_{cclk} < 1$ MHz.

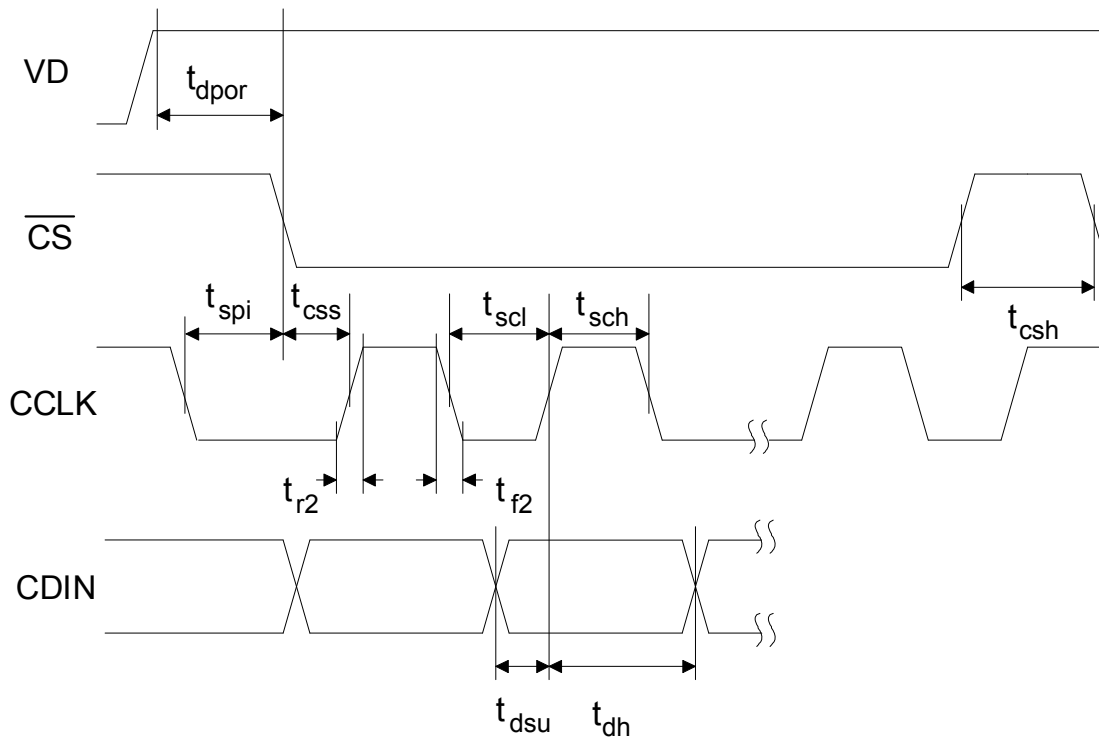

Figure 6. Control Port Timing - SPI Format (Write Only)

4. ARCHITECTURE OVERVIEW

4.1 Delta-Sigma Fractional-N Frequency Synthesizer

The core of the CS2300 is a Delta-Sigma Fractional-N Frequency Synthesizer which has very high-resolution for Input/Output clock ratios, low phase noise, very wide range of output frequencies and the ability to quickly tune to a new frequency. The reference for the synthesizer is an on chip LC Oscillator (LCO) which generates the necessary internal stable clocks. In very simplistic terms, the Fractional-N Frequency Synthesizer multiplies the LC Oscillator by the value of N to generate the PLL output clock. The desired output to input clock ratio is the value of N that is applied to the delta-sigma modulator (see [Figure 7](#)).

The analog PLL based frequency synthesizer uses a low-jitter timing reference clock, the LCO, as a time and phase reference for the internal voltage controlled oscillator (VCO). The phase comparator compares the fractional-N divided clock with the original timing reference and generates a control signal. The control signal is filtered by the internal loop filter to generate the VCO's control voltage which sets its output frequency. The delta-sigma modulator modulates the loop integer divide ratio to get the desired fractional ratio between the reference clock and the VCO output (thus the one's density of the modulator sets the fractional value). This allows the design to be optimized for very fast lock times for a wide range of output frequencies without the need for external filter components.

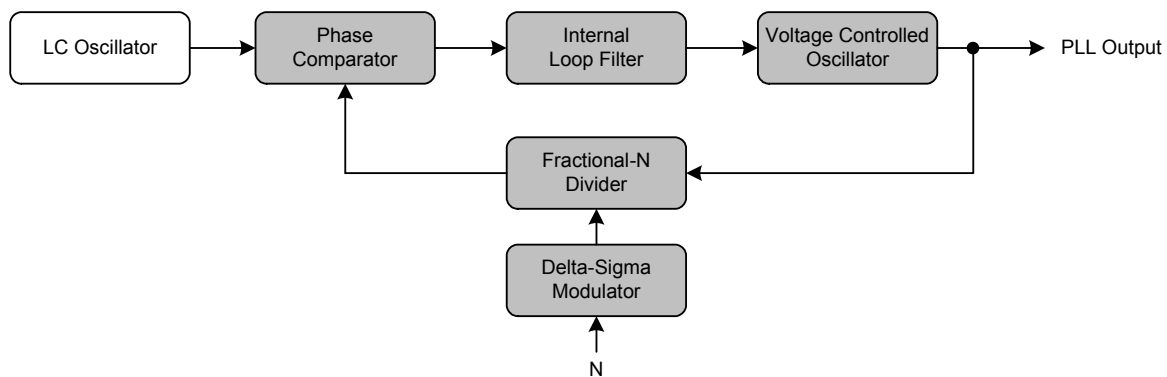

Figure 7. Delta-Sigma Fractional-N Frequency Synthesizer

4.2 Hybrid Analog-Digital Phase Locked Loop

The addition of the Digital PLL and Fractional-N Logic (shown in [Figure 8](#)) to the Fractional-N Frequency Synthesizer creates the Hybrid Analog-Digital Phase Locked Loop with many advantages over classical analog PLL techniques. These advantages include the ability to operate over extremely wide frequency ranges without the need to change external loop filter components while maintaining impressive jitter reduction performance. In the Hybrid architecture, the Digital PLL calculates the ratio of the PLL output clock to the frequency reference and compares that to the desired ratio. The digital logic generates a value of N which is then applied to the Fractional-N frequency synthesizer to generate the desired PLL output frequency. Notice that the frequency and phase of the LCO does not affect the output of the PLL since the digital control loop will correct for the PLL output. A major advantage of the Digital PLL is the ease with which the loop filter bandwidth can be altered. The PLL bandwidth is automatically set to a wide-bandwidth mode to quickly achieve lock and then reduced for optimal jitter rejection.

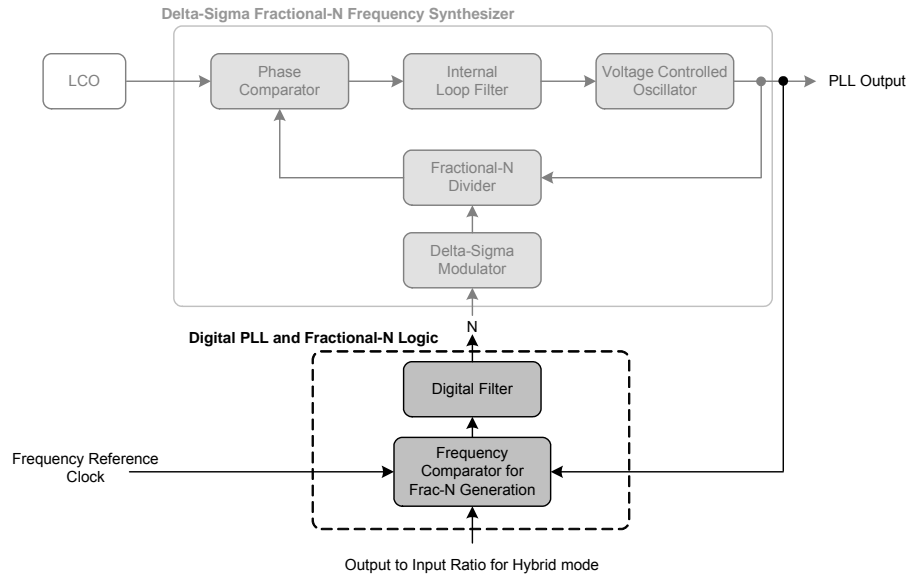

Figure 8. Hybrid Analog-Digital PLL

5. APPLICATIONS

5.1 Timing Reference Clock

The internal LC oscillator is used to generate the internal timing reference clock (see [section 4 “Architecture Overview” on page 11](#) for information on how this internal clock is used by the CS2300). A single 0.1 μF cap must be connected between the FILTP and FILTN pins and the FILTN pin must be connected to ground as shown in [Figure 9](#).

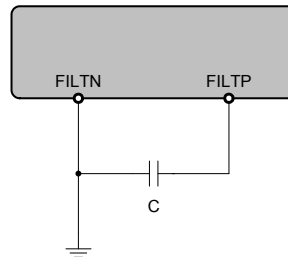

Figure 9. External Component Requirements for LCO

5.2 Frequency Reference Clock Input, CLK_IN

The frequency reference clock input (CLK_IN) is used by the Digital PLL and Fractional-N Logic block to dynamically generate a fractional-N value for the Frequency Synthesizer (see [“Hybrid Analog-Digital PLL” on page 12](#)). The Digital PLL first compares the CLK_IN frequency to the PLL output. The Fractional-N logic block then translates the desired ratio based off of CLK_IN to one based off of the internal LCO. This allows the low-jitter internal LCO to be used as the clock which the Frequency Synthesizer multiplies while maintaining synchronicity with the frequency reference clock through the Digital PLL. The allowable frequency range for CLK_IN is found in the [“AC Electrical Characteristics” on page 7](#).

5.2.1 CLK_IN Skipping Mode

CLK_IN skipping mode allows the PLL to maintain lock even when the CLK_IN signal has missing pulses for up to 20 ms (t_{CS}) at a time (see [“AC Electrical Characteristics” on page 7](#) for specifications). CLK_IN skipping mode can only be used when the CLK_IN frequency is below 80 kHz and CLK_IN is reapplied within 20 ms of being removed. The *ClkSkipEn* bit enables this function.

Regardless of the setting of the *ClkSkipEn* bit the PLL output will continue for 2^{23} LCO cycles (518 ms to 634 ms) after CLK_IN is removed (see [Figure 10](#)). This is true as long as CLK_IN does not glitch or have an effective change in period as the clock source is removed, otherwise the PLL will interpret this as a change in frequency causing clock skipping and the 2^{23} LCO cycle time-out to be bypassed and the PLL to immediately unlock. If the prior conditions are met while CLK_IN is removed and 2^{23} LCO cycles pass, the PLL will unlock and the PLL_OUT state will be determined by the *ClkOutUnl* bit; See [“PLL Clock Output” on page 19](#). If CLK_IN is re-applied after such time, the PLL will remain unlocked for the specified time listed in the [“AC Electrical Characteristics” on page 7](#) after which lock will be acquired and the PLL

output will resume.

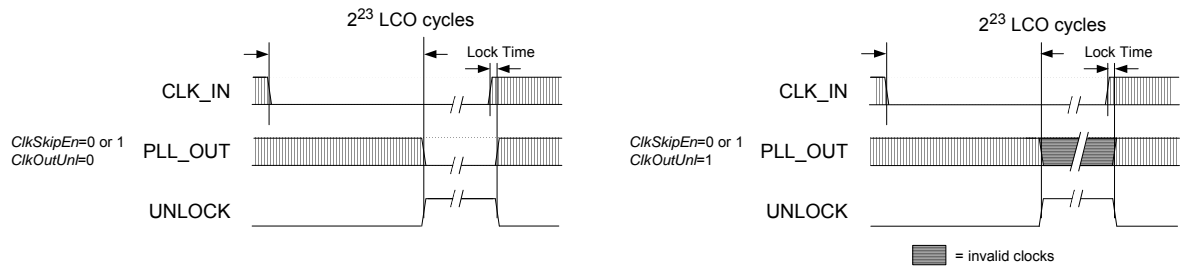

Figure 10. CLK_IN removed for > 2²³ LCO cycles

If it is expected that CLK_IN will be removed and then reapplied within 2²³ LCO cycles but later than t_{CS} , the *ClkSkipEn* bit should be disabled. If it is not disabled, the device will behave as shown in Figure 11; note that the lower figure shows that the PLL output frequency may change and be incorrect without an indication of an unlock condition.

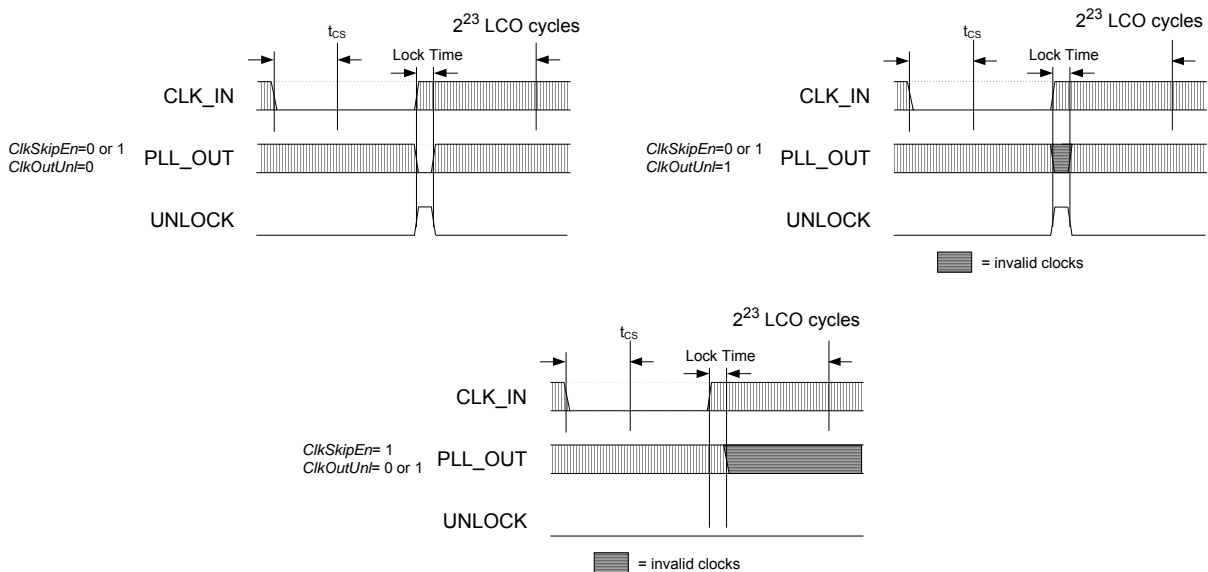

Figure 11. CLK_IN removed for < 2²³ LCO cycles but > t_{CS}

If CLK_IN is removed and then re-applied within t_{CS} , the *ClkSkipEn* bit determines whether PLL_OUT continues while the PLL re-acquires lock (see Figure 12). When *ClkSkipEn* is disabled and CLK_IN is removed the PLL output will continue until CLK_IN is re-applied at which point the PLL will go unlocked only for the time it takes to acquire lock; the PLL_OUT state will be determined by the *ClkOutUnl* bit during this time. When *ClkSkipEn* is enabled and CLK_IN is removed the PLL output clock will remain continuous throughout the missing CLK_IN period including the time while the PLL re-acquires lock.

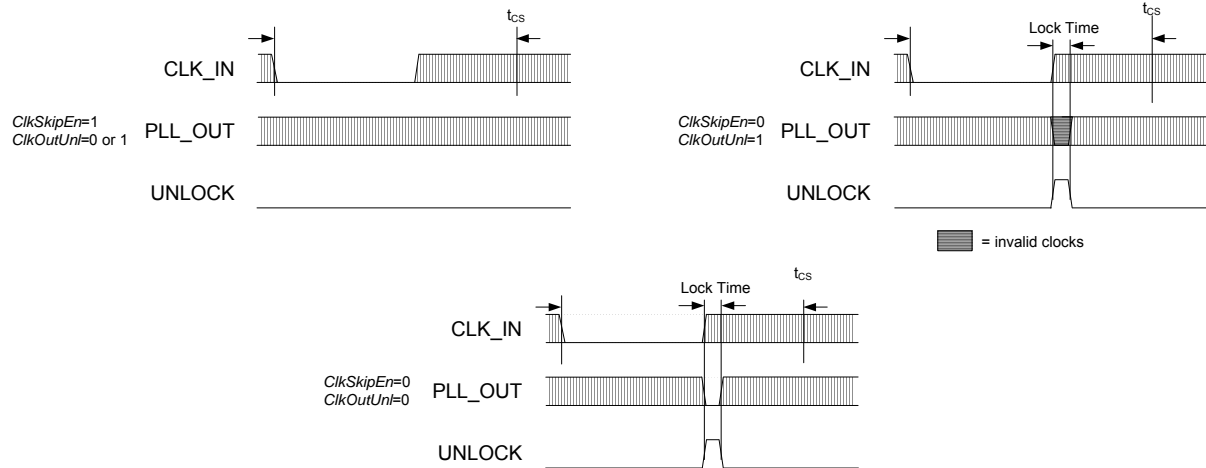

Figure 12. CLK_IN removed for $< t_{CS}$

Referenced Control	Register Location
ClkSkipEn.....	"Clock Skip Enable (ClkSkipEn)" on page 27
ClkOutUnl.....	"Enable PLL Clock Output on Unlock (ClkOutUnl)" on page 28

5.2.2 Adjusting the Minimum Loop Bandwidth for CLK_IN

The CS2300 allows the minimum loop bandwidth of the Digital PLL to be adjusted between 1 Hz and 128 Hz using the *ClkIn_BW[2:0]* bits. The minimum loop bandwidth of the Digital PLL directly affects the jitter transfer function; specifically, jitter frequencies below the loop bandwidth corner are passed from the PLL input directly to the PLL output without attenuation. In some applications it is desirable to have a very low minimum loop bandwidth to reject very low jitter frequencies, commonly referred to as wander. In others it may be preferable to remove only higher frequency jitter, allowing the input wander to pass through the PLL without attenuation.

Typically, applications in which the PLL_OUT signal creates a new clock domain from which all other system clocks and associated data are derived will benefit from the maximum jitter and wander rejection of

the lowest PLL bandwidth setting. See [Figure 13](#).

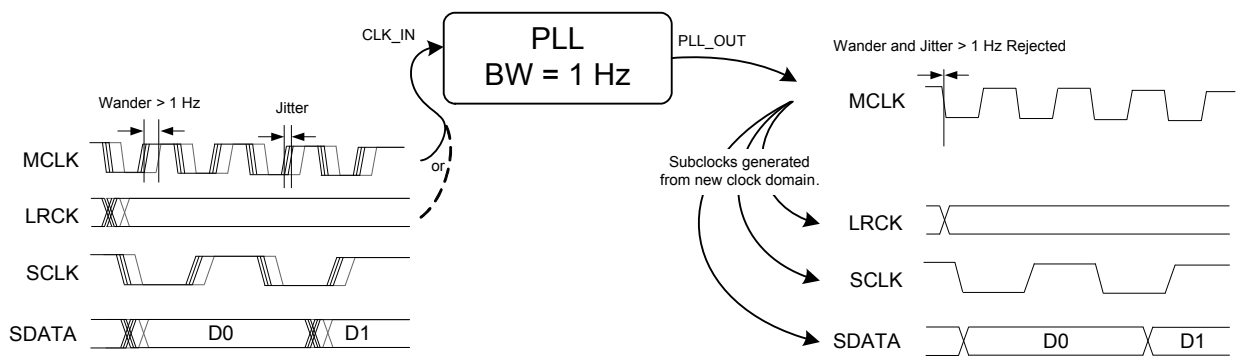

Figure 13. Low bandwidth and new clock domain

Systems in which some clocks and data are derived from the PLL_OUT signal while other clocks and data are derived from the CLK_IN signal will often require phase alignment of all the clocks and data in the system. See [Figure 14](#). If there is substantial wander on the CLK_IN signal in these applications, it may be necessary to increase the minimum loop bandwidth allowing this wander to pass through to the CLK_OUT signal in order to maintain phase alignment. For these applications, it is advised to experiment with the loop bandwidth settings and choose the lowest bandwidth setting that does not produce system timing errors due to wandering between the clocks and data synchronous to the CLK_IN domain and those synchronous to the PLL_OUT domain.

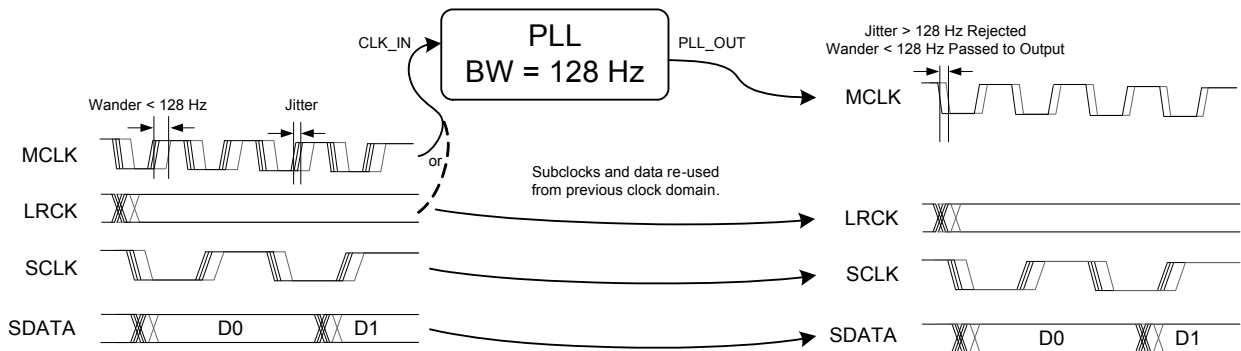

Figure 14. High bandwidth with CLK_IN domain re-use

It should be noted that manual adjustment of the minimum loop bandwidth is not necessary to acquire lock; this adjustment is made automatically by the Digital PLL. While acquiring lock, the digital loop bandwidth is automatically set to a large value. Once lock is achieved, the digital loop bandwidth will settle to the minimum value selected by the *ClkIn_BW[2:0]* bits.

Referenced Control	Register Location
ClkIn_BW[2:0]	"Clock Input Bandwidth (ClkIn_BW[2:0])" on page 28

5.3 Output to Input Frequency Ratio Configuration

5.3.1 User Defined Ratio (R_{UD})

The User Defined Ratio, R_{UD} , is a 32-bit un-signed fixed-point number, stored in the *Ratio* register set, which determines the basis for the desired input to output clock ratio. The 32-bit R_{UD} can be expressed

in either a high resolution (12.20) or high multiplication (20.12) format selectable by the *LFRatioCfg* bit, with 20.12 being the default.

The R_{UD} for high resolution (12.20) format is encoded with 12 MSBs representing the integer binary portion with the remaining 20 LSBs representing the fractional binary portion. The maximum multiplication factor is approximately 4096 with a resolution of 0.954 PPM in this configuration. See “[Calculating the User Defined Ratio](#)” on page 29 for more information.

The R_{UD} for high multiplication (20.12) format is encoded with 20 MSBs representing the integer binary portion with the remaining 12 LSBs representing the fractional binary portion. In this configuration, the maximum multiplication factor is approximately 1,048,575 with a resolution of 244 PPM. It is recommended that the 12.20 High-Resolution format be utilized whenever the desired ratio is less than 4096 since the output frequency accuracy of the PLL is directly proportional to the accuracy of the timing reference clock and the resolution of the R_{UD} .

Referenced Control	Register Location
Ratio.....	“Ratio (Address 06h - 09h)” on page 26
LFRatioCfg.....	“Low-Frequency Ratio Configuration (LFRatioCfg)” on page 28

5.3.2 Ratio Modifier (R-Mod)

The Ratio Modifier is used to internally multiply/divide the R_{UD} (the *Ratio* stored in the register space remains unchanged). The available options for R_{MOD} are summarized in [Table 1 on page 17](#).

The R-Mod value selected by *RModSel[2:0]* is always used in the calculation for the Effective Ratio (R_{EFF}), see “[Effective Ratio \(REFF\)](#)” on page 17. If R-Mod is not desired, *RModSel[2:0]* should be left at its default value of ‘000’, which corresponds to an R-Mod value of 1, thereby effectively disabling the ratio modifier.

RModSel[2:0]	Ratio Modifier
000	1
001	2
010	4
011	8
100	0.5
101	0.25
110	0.125
111	0.0625

Table 1. Ratio Modifier

Referenced Control	Register Location
Ratio.....	“Ratio (Address 06h - 09h)” on page 26
RModSel[2:0]	“R-Mod Selection (RModSel[2:0])” section on page 25

5.3.3 Effective Ratio (R_{EFF})

The Effective Ratio (R_{EFF}) is an internal calculation comprised of R_{UD} and the appropriate modifiers, as previously described. R_{EFF} is calculated as follows:

$$R_{EFF} = R_{UD} \bullet R_{MOD}$$

Ratio modifiers which would produce an overflow or truncation of R_{EFF} should not be used; For example if R_{UD} is 1024 an R_{MOD} of 8 would produce an R_{EFF} value of 8192 which exceeds the 4096 limit of the 12.20 format. In all cases, the maximum and minimum allowable values for R_{EFF} are dictated by the frequency limits for both the input and output clocks as shown in the “AC Electrical Characteristics” on page 7.

5.3.4 Ratio Configuration Summary

The R_{UD} is the user defined ratio stored in the register space. The resolution for the R_{UD} is selectable by setting *LFRatioCfg*. R-Mod is applied if selected. The user defined ratio, and ratio modifier make up the effective ratio R_{EFF} , the final calculation used to determine the output to input clock ratio. The conceptual diagram in Figure 15 summarizes the features involved in the calculation of the ratio values used to generate the fractional-N value which controls the Frequency Synthesizer.

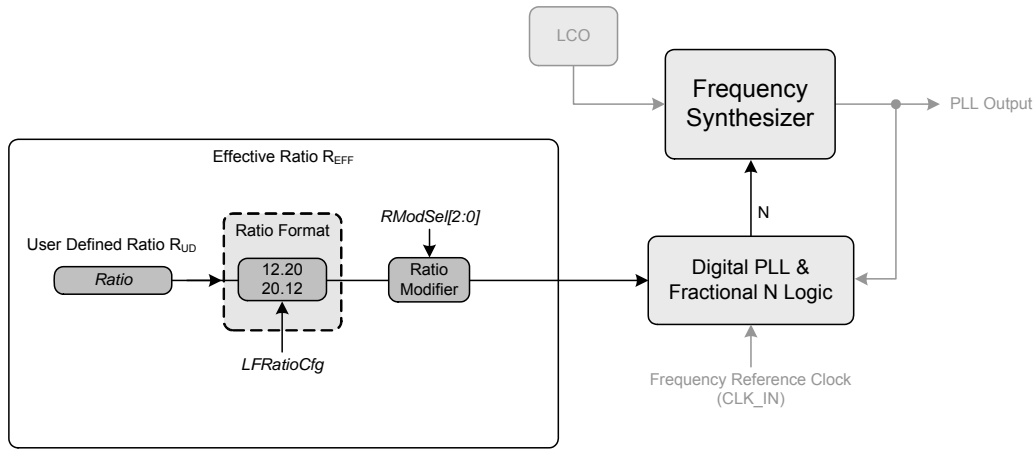

Figure 15. Ratio Feature Summary

Referenced Control	Register Location
Ratio.....	“Ratio (Address 06h - 09h)” on page 26
LFRatioCfg.....	“Low-Frequency Ratio Configuration (LFRatioCfg)” on page 28
RModSel[2:0].....	“R-Mod Selection (RModSel[2:0])” section on page 25

5.4 PLL Clock Output

The PLL clock output pin (CLK_OUT) provides a buffered version of the output of the frequency synthesizer. The driver can be set to high-impedance with the *ClkOutDis* bit.

The output from the PLL automatically drives a static low condition while the PLL is un-locked (when the clock may be unreliable). This feature can be disabled by setting the *ClkOutUnl* bit, however the state CLK_OUT may then be unreliable during an unlock condition.

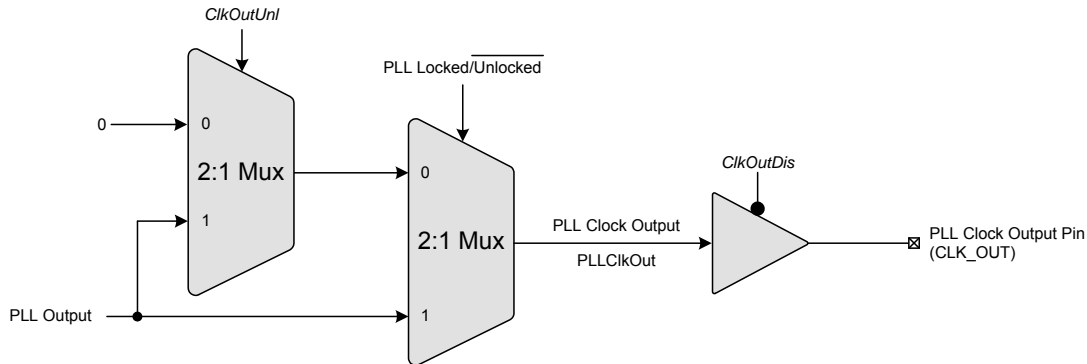

Figure 16. PLL Clock Output Options

Referenced Control	Register Location
ClkOutUnl.....	“Enable PLL Clock Output on Unlock (ClkOutUnl)” on page 28
ClkOutDis.....	“PLL Clock Output Disable (ClkOutDis)” on page 25

5.5 Auxiliary Output

The auxiliary output pin (AUX_OUT) can be mapped, as shown in [Figure 17](#), to one of three signals: input clock (CLK_IN), additional PLL clock output (CLK_OUT), or a PLL lock indicator (Lock). The mux is controlled via the *AuxOutSrc[1:0]* bits. If AUX_OUT is set to Lock, the *AuxLockCfg* bit is then used to control the output driver type and polarity of the LOCK signal (see [section 8.6.2 on page 27](#)). In order to indicate an unlock condition, REF_CLK must be present. If AUX_OUT is set to CLK_OUT the phase of the PLL Clock Output signal on AUX_OUT may differ from the CLK_OUT pin. The driver for the pin can be set to high-impedance using the *AuxOutDis* bit.

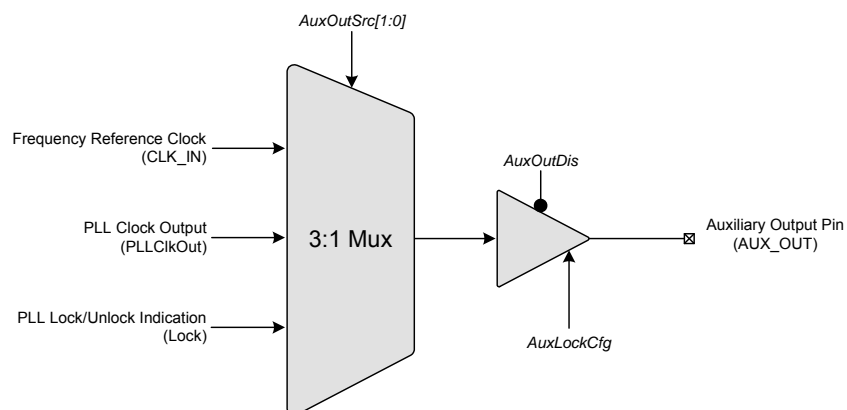

Figure 17. Auxiliary Output Selection

Referenced Control	Register Location
AuxOutSrc[1:0].....	“Auxiliary Output Source Selection (AuxOutSrc[1:0])” on page 25
AuxOutDis.....	“Auxiliary Output Disable (AuxOutDis)” on page 24
AuxLockCfg.....	“AUX PLL Lock Output Configuration (AuxLockCfg)” section on page 27

5.6 Clock Output Stability Considerations

5.6.1 Output Switching

CS2300 is designed such that re-configuration of the clock routing functions do not result in a partial clock period on any of the active outputs (CLK_OUT and/or AUX_OUT). In particular, enabling or disabling an output, and the automatic disabling of the output(s) during unlock will not cause a runt or partial clock period.

The following exceptions/limitations exist:

- Enabling/disabling AUX_OUT when *AuxOutSrc[1:0]* = 11 (unlock indicator).
- Switching *AuxOutSrc[1:0]* to or from 01 (PLL clock input) and to or from 11 (unlock indicator) (Transitions between *AuxOutSrc[1:0]* = [00,10] will not produce a glitch).
- Changing the *ClkOutUnl* bit while the PLL is in operation.

When any of these exceptions occur, a partial clock period on the output may result.

5.6.2 PLL Unlock Conditions

Certain changes to the clock inputs and registers can cause the PLL to lose lock which will affect the presence the clock signal on CLK_OUT. The following outlines which conditions cause the PLL to go unlocked:

- Changes made to the registers which affect the Fraction-N value that is used by the Frequency Synthesizer. This includes all the bits shown in [Figure 15 on page 18](#).
- Any discontinuities on the Timing Reference Clock, REF_CLK.
- Discontinuities on the Frequency Reference Clock, CLK_IN, except when the Clock Skipping feature is enabled and the requirements of Clock Skipping are satisfied (see “CLK_IN Skipping Mode” on [page 13](#)).
- Gradual changes in CLK_IN frequency greater than $\pm 30\%$ from the starting frequency.
- Step changes in CLK_IN frequency.

5.7 Required Power Up Sequencing

- Apply power to the device. The output pins will remain low until the device is configured with a valid ratio via the control port.
- Write the desired operational configurations. The *EnDevCfg1*, *EnDevCfg2*, and *EnDevCfg3* bits must be set to 1 during the initialization register writes; the order does not matter.
 - The *Freeze* bit may be set prior to this step and cleared afterward to ensure all settings take effect at the same time.

6. SPI / I²C CONTROL PORT

The control port is used to access the registers and allows the device to be configured for the desired operational modes and formats. The operation of the control port may be completely asynchronous with respect to device inputs and outputs. However, to avoid potential interference problems, the control port pins should remain static if no operation is required.

The control port operates with either the SPI or I²C interface, with the CS2300 acting as a slave device. SPI Mode is selected if there is a high-to-low transition on the AD0/ $\overline{\text{CS}}$ pin after power-up. I²C Mode is selected by connecting the AD0/ $\overline{\text{CS}}$ pin through a resistor to VD or GND, thereby permanently selecting the desired AD0 bit address state. In both modes the *EnDevCfg1*, *EnDevCfg2*, and *EnDevCfg3* bits must be set to 1 for normal operation.

WARNING: All “Reserved” registers must maintain their default state to ensure proper functional operation.

Referenced Control	Register Location
EnDevCfg1	“Enable Device Configuration Registers 1 (EnDevCfg1)” on page 26
EnDevCfg2	“Enable Device Configuration Registers 2 (EnDevCfg2)” section on page 26
EnDevCfg3	“Enable Device Configuration Registers 3 (EnDevCfg3)” section on page 27

6.1 SPI Control

In SPI Mode, $\overline{\text{CS}}$ is the chip select signal; CCLK is the control port bit clock (sourced from a microcontroller), and CDIN is the input data line from the microcontroller. Data is clocked in on the rising edge of CCLK. The device only supports write operations.

Figure 18 shows the operation of the control port in SPI Mode. To write to a register, bring $\overline{\text{CS}}$ low. The first eight bits on CDIN form the chip address and must be 10011110. The next eight bits form the Memory Address Pointer (MAP), which is set to the address of the register that is to be updated. The next eight bits are the data which will be placed into the register designated by the MAP.

There is MAP auto increment capability, enabled by the INCR bit in the MAP register. If INCR is a zero, the MAP will stay constant for successive read or writes. If INCR is set to a 1, the MAP will automatically increment after each byte is read or written, allowing block writes of successive registers.

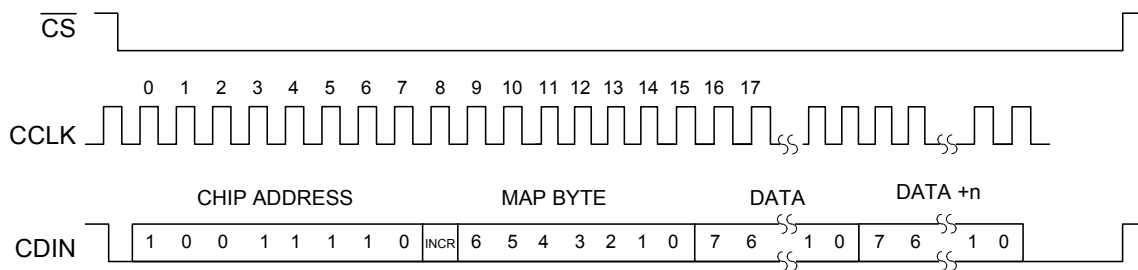

Figure 18. Control Port Timing in SPI Mode

6.2 I²C Control

In I²C Mode, SDA is a bidirectional data line. Data is clocked into and out of the device by the clock, SCL. There is no $\overline{\text{CS}}$ pin. The AD0 pin forms the least-significant bit of the chip address and should be connected to VD or GND as appropriate. The state of the AD0 pin should be maintained throughout operation of the device.

The signal timings for a read and write cycle are shown in Figure 19 and Figure 20. A Start condition is defined as a falling transition of SDA while the clock is high. A Stop condition is a rising transition while the clock is high. All other transitions of SDA occur while the clock is low. The first byte sent to the CS2300 after a Start condition consists of the 7-bit chip address field and a R/W bit (high for a read, low for a write). The upper 6 bits of the 7-bit address field are fixed at 100111 followed by the logic state of the AD0 pin. The eighth bit of the address is the R/W bit. If the operation is a write, the next byte is the Memory Address Pointer (MAP) which selects the register to be read or written. If the operation is a read, the contents of the register pointed to by the MAP will be output. Setting the auto increment bit in MAP allows successive reads or writes of consecutive registers. Each byte is separated by an acknowledge bit. The ACK bit is output from the CS2300 after each input byte is read and is input from the microcontroller after each transmitted byte.

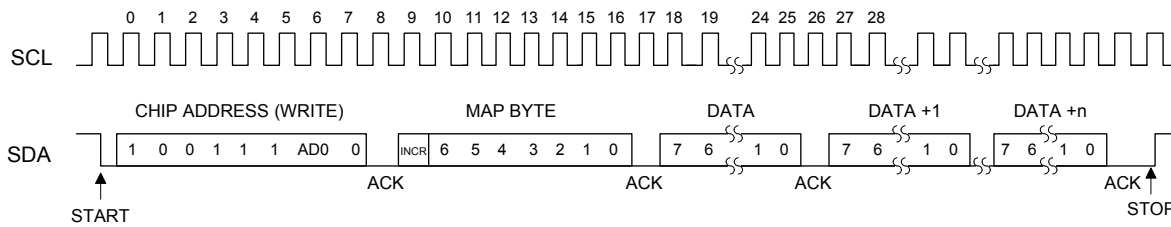

Figure 19. Control Port Timing, I²C Write

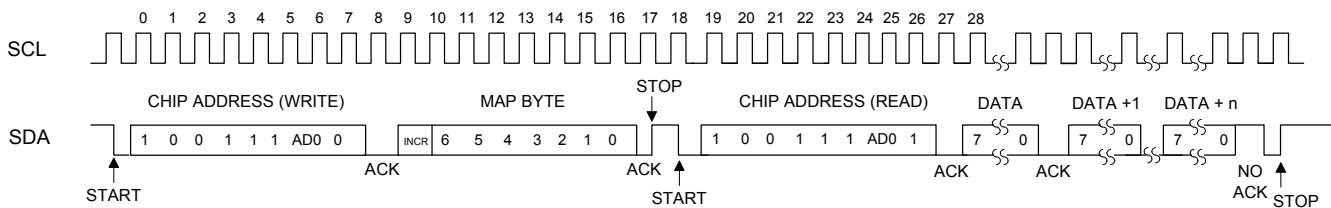

Figure 20. Control Port Timing, I²C Aborted Write + Read

Since the read operation cannot set the MAP, an aborted write operation is used as a preamble. As shown in [Figure 19](#), the write operation is aborted after the acknowledge for the MAP byte by sending a stop condition. The following pseudocode illustrates an aborted write operation followed by a read operation.

- Send start condition.
- Send 100111x0 (chip address & write operation).
- Receive acknowledge bit.
- Send MAP byte, auto increment off.
- Receive acknowledge bit.
- Send stop condition, aborting write.
- Send start condition.
- Send 100111x1(chip address & read operation).
- Receive acknowledge bit.
- Receive byte, contents of selected register.
- Send acknowledge bit.
- Send stop condition.

Setting the auto increment bit in the MAP allows successive reads or writes of consecutive registers. Each byte is separated by an acknowledge bit.

6.3 Memory Address Pointer

The Memory Address Pointer (MAP) byte comes after the address byte and selects the register to be read or written. Refer to the pseudocode above for implementation details.

6.3.1 Map Auto Increment

The device has MAP auto increment capability enabled by the INCR bit (the MSB) of the MAP. If INCR is set to 0, MAP will stay constant for successive I²C writes or reads and SPI writes. If INCR is set to 1, MAP will auto increment after each byte is read or written, allowing block reads or writes of successive registers.

7. REGISTER QUICK REFERENCE

This table shows the register and bit names with their associated default values.

EnDevCfg1, *EnDevCfg2*, and *EnDevCfg3* bits must be set to 1 for normal operation.

WARNING: All “Reserved” registers must maintain their default state to ensure proper functional operation.

Adr	Name	7	6	5	4	3	2	1	0
01h p 24	Device ID	Device4 0	Device3 0	Device2 0	Device1 0	Device0 0	Revision2 x	Revision1 x	Revision0 x
02h p 24	Device Ctrl	Unlock x	Reserved x	Reserved x	Reserved 0	Reserved 0	Reserved 0	AuxOutDis 0	ClkOutDis 0
03h p 25	Device Cfg 1	RModSel2 0	RModSel1 0	RModSel0 0	Reserved 0	Reserved 0	AuxOutSrc1 0	AuxOutSrc0 0	EnDevCfg1 0
05h p 26	Global Cfg	Reserved 0	Reserved 0	Reserved 0	Reserved 0	Freeze 0	Reserved 0	Reserved 0	EnDevCfg2 0
06h - 09h	32-Bit Ratio	MSB MSB-8 LSB+15 LSB+7							MSB-7 MSB-15 LSB+8 LSB
16h p 27	Funct Cfg 1	ClkSkipEn 0	AuxLockCfg 0	Reserved 0	EnDevCfg3 0	Reserved 0	Reserved 0	Reserved 0	Reserved 0
17h p 28	Funct Cfg 2	Reserved 0	Reserved 0	Reserved 0	ClkOutUnl 0	LFRatioCfg 0	Reserved 0	Reserved 0	Reserved 0
1Eh p 28	Funct Cfg 3	Reserved 0	ClkIn_BW2 0	ClkIn_BW1 0	ClkIn_BW0 0	Reserved 0	Reserved 0	Reserved 0	Reserved 0

8. REGISTER DESCRIPTIONS

In I²C Mode all registers are read/write unless otherwise stated. In SPI mode all registers are write only. All “Reserved” registers must maintain their default state to ensure proper functional operation. The default state of each bit after a power-up sequence or reset is indicated by the shaded row in the bit decode table and in the “[Register Quick Reference](#)” on page 23.

Control port mode is entered when the device recognizes a valid chip address input on its I²C/SPI serial control pins and the *EnDevCfg1*, *EnDevCfg2*, and *EnDevCfg3* bits are set to 1.

8.1 Device I.D. and Revision (Address 01h)

7	6	5	4	3	2	1	0
Device4	Device3	Device2	Device1	Device0	Revision2	Revision1	Revision0

8.1.1 Device Identification (Device[4:0]) - Read Only

I.D. code for the CS2300.

Device[4:0]	Device
00000	CS2300.

8.1.2 Device Revision (Revision[2:0]) - Read Only

CS2300 revision level.

REVID[2:0]	Revision Level
100	B2 and B3
110	C1

8.2 Device Control (Address 02h)

7	6	5	4	3	2	1	0
Unlock	Reserved	Reserved	Reserved	Reserved	Reserved	AuxOutDis	ClkOutDis

8.2.1 Unlock Indicator (Unlock) - Read Only

Indicates the lock state of the PLL.

Unlock	PLL Lock State
0	PLL is Locked.
1	PLL is Unlocked.

Note: Bit 7 is sticky until read.

8.2.2 Auxiliary Output Disable (AuxOutDis)

This bit controls the output driver for the AUX_OUT pin.

AuxOutDis	Output Driver State
0	AUX_OUT output driver enabled.
1	AUX_OUT output driver set to high-impedance.
Application:	“ Auxiliary Output ” on page 19

8.2.3 PLL Clock Output Disable (ClkOutDis)

This bit controls the output driver for the CLK_OUT pin.

ClkOutDis	Output Driver State
0	CLK_OUT output driver enabled.
1	CLK_OUT output driver set to high-impedance.
Application:	“PLL Clock Output” on page 19

8.3 Device Configuration 1 (Address 03h)

7	6	5	4	3	2	1	0
RModSel2	RModSel1	RModSel0	Reserved	Reserved	AuxOutSrc1	AuxOutSrc0	EnDevCfg1

8.3.1 R-Mod Selection (RModSel[2:0])

Selects the R-Mod value, which is used as a factor in determining the PLL's Fractional N.

RModSel[2:0]	R-Mod Selection
000	Left-shift R-value by 0 (x 1).
001	Left-shift R-value by 1 (x 2).
010	Left-shift R-value by 2 (x 4).
011	Left-shift R-value by 3 (x 8).
100	Right-shift R-value by 1 ($\div 2$).
101	Right-shift R-value by 2 ($\div 4$).
110	Right-shift R-value by 3 ($\div 8$).
111	Right-shift R-value by 4 ($\div 16$).
Application:	“Ratio Modifier (R-Mod)” on page 17

8.3.2 Auxiliary Output Source Selection (AuxOutSrc[1:0])

Selects the source of the AUX_OUT signal.

AuxOutSrc[1:0]	Auxiliary Output Source
00	Reserved.
01	CLK_IN.
10	CLK_OUT.
11	PLL Lock Status Indicator.
Application:	“Auxiliary Output” on page 19

Note: When set to 11, *AuxLckCfg* sets the polarity and driver type. See [“AUX PLL Lock Output Configuration \(AuxLockCfg\)” on page 27](#).

8.3.3 Enable Device Configuration Registers 1 (*EnDevCfg1*)

This bit, in conjunction with *EnDevCfg2* and *EnDevCfg3*, configures the device for control port mode. These *EnDevCfg* bits can be set in any order and at any time during the control port access sequence, however they must all be set before normal operation can occur.

EnDevCfg1	Register State
0	Disabled.
1	Enabled.
Application:	"SPI / I ² C Control Port" on page 20

Note: *EnDevCfg2* and *EnDevCfg3* must also be set to enable control port mode. See "SPI / I²C Control Port" on page 20.

8.4 Global Configuration (Address 05h)

7	6	5	4	3	2	1	0
Reserved	Reserved	Reserved	Reserved	Freeze	Reserved	Reserved	EnDevCfg2

8.4.1 Device Configuration Freeze (*Freeze*)

Setting this bit allows writes to the Device Control and Device Configuration registers (address 02h - 04h) but keeps them from taking effect until this bit is cleared.

FREEZE	Device Control and Configuration Registers
0	Register changes take effect immediately.
1	Modifications may be made to Device Control and Device Configuration registers (registers 02h-04h) without the changes taking effect until after the FREEZE bit is cleared.

8.4.2 Enable Device Configuration Registers 2 (*EnDevCfg2*)

This bit, in conjunction with *EnDevCfg1* and *EnDevCfg3*, configures the device for control port mode. These *EnDevCfg* bits can be set in any order and at any time during the control port access sequence, however they must all be set before normal operation can occur.

EnDevCfg2	Register State
0	Disabled.
1	Enabled.
Application:	"SPI / I ² C Control Port" on page 20

Note: *EnDevCfg1* and *EnDevCfg3* must also be set to enable control port mode. See "SPI / I²C Control Port" on page 20.

8.5 Ratio (Address 06h - 09h)

7	6	5	4	3	2	1	0
MSB	MSB-7
MSB-8	MSB-15
LSB+15	LSB+8
LSB+7	LSB

These registers contain the User Defined Ratio as shown in the "Register Quick Reference" section on page 23. These 4 registers form a single 32-bit ratio value as shown above. See "Output to Input Frequency Ratio Configuration" on page 16 and "Calculating the User Defined Ratio" on page 29 for more details.

8.6 Function Configuration 1 (Address 16h)

7	6	5	4	3	2	1	0
ClkSkipEn	AuxLockCfg	Reserved	EnDevCfg3	Reserved	Reserved	Reserved	Reserved

8.6.1 Clock Skip Enable (ClkSkipEn)

This bit enables clock skipping mode for the PLL and allows the PLL to maintain lock even when the CLK_IN has missing pulses.

ClkSkipEn	PLL Clock Skipping Mode
0	Disabled.
1	Enabled.
Application:	"CLK_IN Skipping Mode" on page 13

Note: f_{CLK_IN} must be < 80 kHz and re-applied within 20 ms to use this feature.

8.6.2 AUX PLL Lock Output Configuration (AuxLockCfg)

When the AUX_OUT pin is configured as a lock indicator ($AuxOutSrc[1:0] = 11$), this bit configures the AUX_OUT driver to either push-pull or open drain. It also determines the polarity of the lock signal. If AUX_OUT is configured as a clock output, the state of this bit is disregarded.

AuxLockCfg	AUX_OUT Driver Configuration
0	Push-Pull, Active High (output 'high' for unlocked condition, 'low' for locked condition).
1	Open Drain, Active Low (output 'low' for unlocked condition, high-Z for locked condition).
Application:	"Auxiliary Output" on page 19

Note: AUX_OUT is an **unlock** indicator, signalling an error condition when the PLL is unlocked. Therefore, the pin polarity is defined relative to the **unlock** condition.

8.6.3 Enable Device Configuration Registers 3 (EnDevCfg3)

This bit, in conjunction with $EnDevCfg1$ and $EnDevCfg2$, configures the device for control port mode. These $EnDevDfg$ bits can be set in any order and at any time during the control port access sequence, however they must all be set before normal operation can occur.

EnDevCfg3	Register State
0	Disabled.
1	Enabled.
Application:	"SPI / I²C Control Port" on page 20

Note: $EnDevCfg1$ and $EnDevCfg2$ must also be set to enable control port mode. See ["SPI / I²C Control Port" on page 20](#).

8.7 Function Configuration 2 (Address 17h)

7	6	5	4	3	2	1	0
Reserved	Reserved	Reserved	ClkOutUnl	LFRatioCfg	Reserved	Reserved	Reserved

8.7.1 Enable PLL Clock Output on Unlock (ClkOutUnl)

Defines the state of the PLL output during the PLL unlock condition.

ClkOutUnl	Clock Output Enable Status
0	Clock outputs are driven 'low' when PLL is unlocked.
1	Clock outputs are always enabled (results in unpredictable output when PLL is unlocked).
Application:	"PLL Clock Output" on page 19

8.7.2 Low-Frequency Ratio Configuration (LFRatioCfg)

Determines how to interpret the 32-bit User Defined Ratio.

LFRatioCfg	Ratio Bit Encoding Interpretation
0	20.12 - High Multiplier.
1	12.20 - High Accuracy.
Application:	"User Defined Ratio (RUD)" on page 16

8.8 Function Configuration 3 (Address 1Eh)

7	6	5	4	3	2	1	0
Reserved	ClkIn_BW2	ClkIn_BW1	ClkIn_BW0	Reserved	Reserved	Reserved	Reserved

8.8.1 Clock Input Bandwidth (ClkIn_BW[2:0])

Sets the minimum loop bandwidth when locked to CLK_IN.

ClkIn_BW[2:0]	Minimum Loop Bandwidth
000	1 Hz
001	2 Hz
010	4 Hz
011	8 Hz
100	16 Hz
101	32 Hz
110	64 Hz
111	128 Hz
Application:	"Adjusting the Minimum Loop Bandwidth for CLK_IN" on page 15

Note: In order to guarantee that a change in minimum bandwidth takes effect, these bits must be set prior to acquiring lock (removing and re-applying CLK_IN can provide the unlock condition necessary to initiate the setting change). In production systems these bits should be configured with the desired values prior to setting the *EnDevCfg* bits; this guarantees that the setting takes effect prior to acquiring lock.

9. CALCULATING THE USER DEFINED RATIO

Note: The software for use with the evaluation kit has built in tools to aid in calculating and converting the User Defined Ratio. This section is for those who are not interested in the software or who are developing their systems without the aid of the evaluation kit.

Most calculators do not interpret the fixed point binary representation which the CS2300 uses to define the output to input clock ratio (see [Section 5.3.1 on page 16](#)); However, with a simple conversion we can use these tools to generate a binary or hex value which can be written to the *Ratio* register.

9.1 High Resolution 12.20 Format

To calculate the User Defined Ratio (R_{UD}) to store in the register(s), divide the desired output clock frequency by the given input clock (CLK_IN). Then multiply the desired ratio by the scaling factor of 2^{20} to get the scaled decimal representation; then use the decimal to binary/hex conversion function on a calculator and write to the register. A few examples have been provided in [Table 2](#).

Desired Output to Input Clock Ratio (output clock/input clock)	Scaled Decimal Representation = (output clock/input clock) • 2^{20}	Hex Representation of Binary R_{UD}
12.288 MHz/10 MHz=1.2288	1288490	00 13 A9 2A
11.2896 MHz/44.1 kHz=256	268435456	10 00 00 00

Table 2. Example 12.20 R-Values

9.2 High Multiplication 20.12 Format

To calculate the User Defined Ratio (R_{UD}) to store in the register(s), divide the desired output clock frequency by the given input clock (CLK_IN). Then multiply the desired ratio by the scaling factor of 2^{12} to get the scaled decimal representation; then use the decimal to binary/hex conversion function on a calculator and write to the register. A few examples have been provided in [Table 3](#).

Desired Output to Input Clock Ratio (output clock/input clock)	Scaled Decimal Representation = (output clock/input clock) • 2^{12}	Hex Representation of Binary R_{UD}
12.288 MHz/60 Hz=204,800	838860800	32 00 00 00
11.2896 MHz/59.97 Hz =188254.127...	771088904	2D F5 E2 08

Table 3. Example 20.12 R-Values

10. PACKAGE DIMENSIONS

10L MSOP (3 mm BODY) PACKAGE DRAWING (Note 1)

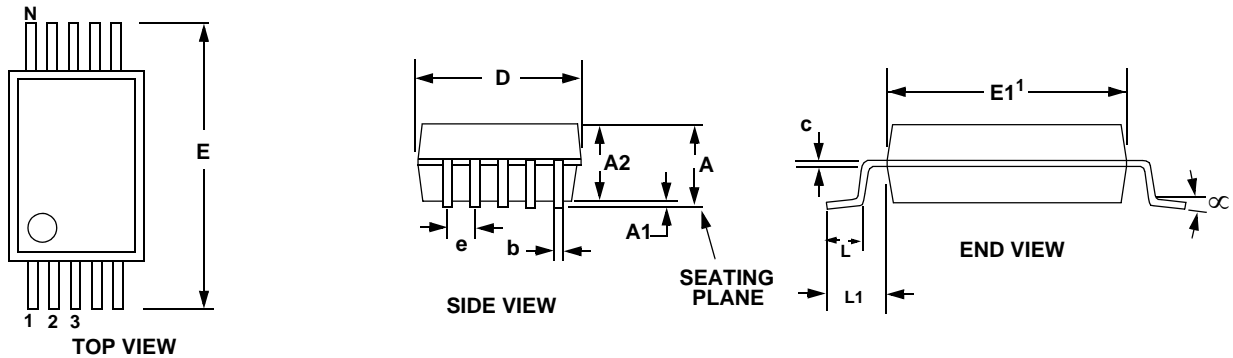

DIM	INCHES			MILLIMETERS			NOTE
	MIN	NOM	MAX	MIN	NOM	MAX	
A	--	--	0.0433	--	--	1.10	
A1	0	--	0.0059	0	--	0.15	
A2	0.0295	--	0.0374	0.75	--	0.95	
b	0.0059	--	0.0118	0.15	--	0.30	4, 5
c	0.0031	--	0.0091	0.08	--	0.23	
D	--	0.1181 BSC	--	--	3.00 BSC	--	2
E	--	0.1929 BSC	--	--	4.90 BSC	--	
E1	--	0.1181 BSC	--	--	3.00 BSC	--	3
e	--	0.0197 BSC	--	--	0.50 BSC	--	
L	0.0157	0.0236	0.0315	0.40	0.60	0.80	
L1	--	0.0374 REF	--	--	0.95 REF	--	

Notes: 1. Reference document: JEDEC MO-187

2. D does not include mold flash or protrusions which is 0.15 mm max. per side.
3. E1 does not include inter-lead flash or protrusions which is 0.15 mm max per side.
4. Dimension b does not include a total allowable dambar protrusion of 0.08 mm max.
5. Exceptions to JEDEC dimension.

THERMAL CHARACTERISTICS

Parameter	Symbol	Min	Typ	Max	Units
Junction to Ambient Thermal Impedance	JEDEC 2-Layer θ_{JA}	-	170	-	°C/W
	JEDEC 4-Layer θ_{JA}	-	100	-	°C/W
Junction to Case Thermal Impedance	θ_{JC}	-	30.2	-	°C/W
Junction to Top Thermal Characteristic (Center of Package)	Ψ_{JT}	-	6	-	°C/W

11. ORDERING INFORMATION

Product	Description	Package	Pb-Free	Grade	Temp Range	Container	Order#
CS2300-CP	Clocking Device	10L-MSOP	Yes	Commercial	-10° to +70°C	Rail	CS2300CP-CZZ
CS2300-CP	Clocking Device	10L-MSOP	Yes		-10° to +70°C	Tape and Reel	CS2300CP-CZZR
CS2300-CP	Clocking Device	10L-MSOP	Yes	Automotive-D	-40° to +85°C	Rail	CS2300CP-DZZ
CS2300-CP	Clocking Device	10L-MSOP	Yes		-40° to +85°C	Tape and Reel	CS2300CP-DZZR
CS2300-CP	Clocking Device	10L-MSOP	Yes	Automotive-E	-40° to +105°C	Rail	CS2300CP-EZZ
CS2300-CP	Clocking Device	10L-MSOP	Yes		-40° to +105°C	Tape and Reel	CS2300CP-EZZR
CDK2000	Evaluation Platform	-	Yes	-	-	-	CDK2000-LCO

12. REVISION HISTORY

Release	Changes
F1 AUG '09	<p>Updated Period Jitter specification in "AC Electrical Characteristics" on page 7.</p> <p>Added "PLL Performance Plots 9" section on page 2.</p> <p>Updated use conditions for "CLK_IN Skipping Mode" section on page 13 and page 27.</p> <p>Updated Figure 10 on page 14.</p> <p>Removed FsDetect and Auto R-Mod features per ER758rev2.</p>
F2 MAY '10	Updated to add Automotive Grade temperature ranges and ordering options.
F3 OCT '15	<p>Updated to add Automotive-E grade temperature ranges and ordering options.</p> <p>Added Note 6 regarding ratio-limited f_{CLK_OUT} in "AC Electrical Characteristics" on page 7.</p> <p>Updated frequency ranges in Figure 2 on page 8 and Figure 3 on page 8.</p> <p>Added unlock conditions to "Auxiliary Output" on page 19.</p> <p>Added note regarding Bit 7 in "Device Control (Address 02h)" on page 24.</p> <p>Added two thermal characteristics in "Thermal Characteristics" on page 30.</p> <p>Updated legal verbiage.</p>

Important: Please check www.Cirrus.com to confirm that you are using the latest revision of this document and to determine whether there are errata associated with this device.

Contacting Cirrus Logic Support

For all product questions and inquiries, contact a Cirrus Logic Sales Representative.
To find one nearest you, go to www.cirrus.com

IMPORTANT NOTICE

The products and services of Cirrus Logic International (UK) Limited; Cirrus Logic, Inc.; and other companies in the Cirrus Logic group (collectively either "Cirrus Logic" or "Cirrus") are sold subject to Cirrus's terms and conditions of sale supplied at the time of order acknowledgment, including those pertaining to warranty, indemnification, and limitation of liability. Software is provided pursuant to applicable license terms. Cirrus reserves the right to make changes to its products and specifications or to discontinue any product or service without notice. Customers should therefore obtain the latest version of relevant information from Cirrus to verify that the information is current and complete. Testing and other quality control techniques are utilized to the extent Cirrus deems necessary. Specific testing of all parameters of each device is not necessarily performed. In order to minimize risks associated with customer applications, the customer must use adequate design and operating safeguards to minimize inherent or procedural hazards. Cirrus is not liable for applications assistance or customer product design. The customer is solely responsible for its selection and use of Cirrus products. Use of Cirrus products may entail a choice between many different modes of operation, some or all of which may require action by the user, and some or all of which may be optional. Nothing in these materials should be interpreted as instructions or suggestions to choose one mode over another. Likewise, description of a single mode should not be interpreted as a suggestion that other modes should not be used or that they would not be suitable for operation. Features and operations described herein are for illustrative purposes only.

CERTAIN APPLICATIONS USING SEMICONDUCTOR PRODUCTS MAY INVOLVE POTENTIAL RISKS OF DEATH, PERSONAL INJURY, OR SEVERE PROPERTY OR ENVIRONMENTAL DAMAGE ("CRITICAL APPLICATIONS"). CIRRUS PRODUCTS ARE NOT DESIGNED, AUTHORIZED OR WARRANTED FOR USE IN PRODUCTS SURGICALLY IMPLANTED INTO THE BODY, AUTOMOTIVE SAFETY OR SECURITY DEVICES, NUCLEAR SYSTEMS, LIFE SUPPORT PRODUCTS OR OTHER CRITICAL APPLICATIONS. INCLUSION OF CIRRUS PRODUCTS IN SUCH APPLICATIONS IS UNDERSTOOD TO BE FULLY AT THE CUSTOMER'S RISK AND CIRRUS DISCLAIMS AND MAKES NO WARRANTY, EXPRESS, STATUTORY OR IMPLIED, INCLUDING THE IMPLIED WARRANTIES OF MERCHANTABILITY AND FITNESS FOR PARTICULAR PURPOSE, WITH REGARD TO ANY CIRRUS PRODUCT THAT IS USED IN SUCH A MANNER. IF THE CUSTOMER OR CUSTOMER'S CUSTOMER USES OR PERMITS THE USE OF CIRRUS PRODUCTS IN CRITICAL APPLICATIONS, CUSTOMER AGREES, BY SUCH USE, TO FULLY INDEMNIFY CIRRUS, ITS OFFICERS, DIRECTORS, EMPLOYEES, DISTRIBUTORS AND OTHER AGENTS FROM ANY AND ALL LIABILITY, INCLUDING ATTORNEYS' FEES AND COSTS, THAT MAY RESULT FROM OR ARISE IN CONNECTION WITH THESE USES.

This document is the property of Cirrus and by furnishing this information, Cirrus grants no license, express or implied, under any patents, mask work rights, copyrights, trademarks, trade secrets or other intellectual property rights. Any provision or publication of any third party's products or services does not constitute Cirrus's approval, license, warranty or endorsement thereof. Cirrus gives consent for copies to be made of the information contained herein only for use within your organization with respect to Cirrus integrated circuits or other products of Cirrus, and only if the reproduction is without alteration and is accompanied by all associated copyright, proprietary and other notices and conditions (including this notice). This consent does not extend to other copying such as copying for general distribution, advertising or promotional purposes, or for creating any work for resale. This document and its information is provided "AS IS" without warranty of any kind (express or implied). All statutory warranties and conditions are excluded to the fullest extent possible. No responsibility is assumed by Cirrus for the use of information herein, including use of this information as the basis for manufacture or sale of any items, or for infringement of patents or other rights of third parties. Cirrus Logic, Cirrus, the Cirrus Logic logo design, and SoundClear are among the trademarks of Cirrus. Other brand and product names may be trademarks or service marks of their respective owners.

Copyright © 2009–2015 Cirrus Logic, Inc. All rights reserved.

SPI is a trademark of Motorola.