

## AFBR-2310Z

### Fiber-Optic Receiver for Multi GHz Analog Links



## Description

The Broadcom<sup>®</sup> AFBR-2310Z is a compact, high-performance, cost-effective receiver for multi GHz analog communication over single-mode optical fiber.

The receiver incorporates a wide bandwidth, low dark current InGaAs/InP PIN photodiode packaged inside a TO-header, together with a high performance E-pHEMT RF amplifier and its bias network.

A receptacle designed according to the CEI/IEC 61754-13 standard allows coupling of the optical signal by means of a FC fiber patchcord.

The receiver is optimized for operation at 1310 nm and 1550 nm but may be used over a wide wavelength range ranging from 850 nm to 1600 nm, with reduced performance.

The amplifier low noise figure and PIN high responsivity allow for a high sensitivity and thus a high-splitting ratio in branched passive optical networks.

Access to the RF output as well as bias of PIN and amplifier is through a flexible printed circuit board. The RF output requires external AC coupling.

The receptacle is designed for assembly into a properly shaped aperture in the customer box wall or fixture.

## Features

- Compact package
- Low dark current PIN
- High-performance RF amplifier
- FC single-mode fiber connectorized optical receptacle
- Low power consumption
- Flex interconnect to customer PCB
- Minimal external circuitry required
- RoHS6 compliant
- Pairs to AFBR-1310Z, Fiber Optic Transmitter for Multi GHz analog links

## Specifications

- Nominal 50Ω RF output impedance
- 3.3V RF amplifier and PIN bias voltage
- 200 V/W typical conversion gain
- 200-MHz to 5.5-GHz frequency range

## Applications

- Analog optical links for satellite signal distribution
- In-building antenna remote systems

## Table 1. Absolute Maximum Ratings

**NOTE:** Absolute maximum ratings are those values beyond which functional performance is not intended, device reliability is not implied, and damage to the device may occur.

| Parameter                           | Symbol              | Minimum | Typical | Maximum | Units | Notes  |
|-------------------------------------|---------------------|---------|---------|---------|-------|--|
| Storage Temperature (non-operating) | Ts                  | -40     | —       | 85      | C     |  |
| Operating Temperature               | Ta                  | -40     | —       | 85      | C     |  |
| Relative Humidity (non-condensing)  | RH                  | —       | —       | 85      | %     |  |
| RF amplifier/PIN supply voltage     |                     | 0       | —       | 5.0     | V     |  |
| Optical Input Power                 | Pin                 | —       | —       | 7       | dBm   |  |
| RF Amplifier Output DC Voltage      | Vout                | —       | —       | 5       | V     |  |
| ESD Capability (HBM)                | V <sub>ESDHBM</sub> | —       | —       | 250     | V     |  |
| Flex Soldering Temperature          |                     | —       | —       | 300     | °C    | For manual soldering, no longer than 2 s/pad. It is advisable to preheat the customer PCB. |

## Table 2. Recommended Operating Conditions

**NOTE:** Typical operating conditions are those values for which functional performance and device reliability is implied.

| Parameter                          | Symbol | Minimum | Typical | Maximum | Units | Notes |
|------------------------------------|--------|---------|---------|---------|-------|-------|
| Operating Temperature              | Ta     | 0       | —       | 85      | °C    |       |
| Relative Humidity (non-condensing) | RH     | —       | —       | 80      | %     |       |
| RF Amplifier Supply Voltage        | Vcc    | 3.135   | 3.3     | 3.465   | V     |       |

## Table 3. Electro-Optical Specifications

**NOTE:** All O/E parameters refer to 1310-nm and 1550-nm wavelength optical input signals.

| Parameter                   | Symbol          | Conditions      | Min. | Nom. | Max. | Units | Notes             |
|-----------------------------|-----------------|-----------------|------|------|------|-------|-------------------|
| RF Output Impedance         | Ro              |                 | —    | 50   | —    | W     |                   |
| Gain Ripple                 | ΔG              | 0.2 to 5.5 GHz  | —    | 4    | —    | dB    |                   |
| RF Conversion Gain          | G               |                 | —    | 200  | —    | V/W   | At 1 GHz          |
| RF Amplifier Supply Current | I <sub>cc</sub> | T = 0°C to 85°C | 16   | —    | 40   | mA    | No light input    |
| Input Referred Noise        |                 | T = 0°C to 85°C | —    | 10   | —    | pW/Hz |                   |
| Wavelength rRange           | λ               |                 | 850  | 1310 | 1600 | nm    | Note <sup>a</sup> |
| 3 dB Bandwidth              |                 |                 | —    | 7    | —    | GHz   |                   |
| Low Cutoff Frequency        |                 |                 | —    | 40   | —    | MHz   |                   |
| Input Optical Power         |                 |                 | —    | —    | 2    | dBm   |                   |

a. The receiver is optimized for operation at 1310 nm and 1550 nm but may be used over a wide wavelength range ranging from 850 nm to 1600 nm, with reduced performance.

# Schematic Diagram

Figure 1: Schematic Diagram

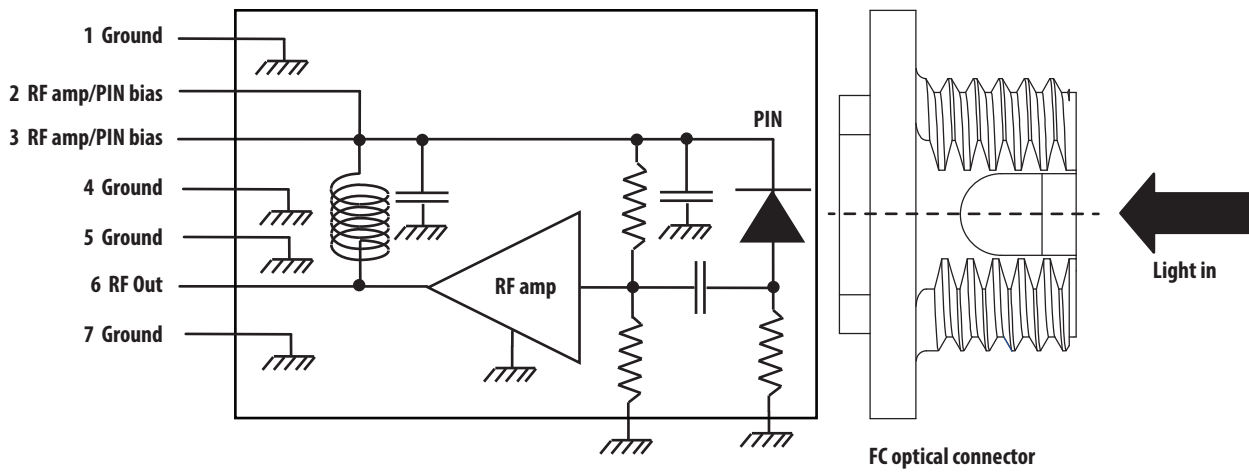

# Electrical Pinout

Figure 2: Electrical Pinout (Top View after 90° Bending of the Flexible PCB)

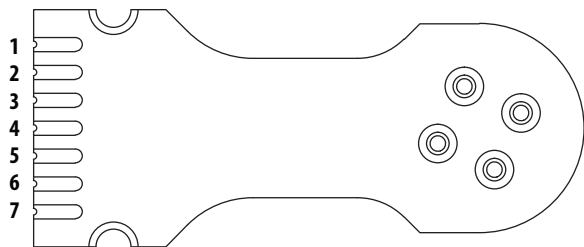

| Pad | Function        |
|-----|-----------------|
| 1   | Ground          |
| 2   | RF amp/PIN bias |
| 3   | RF amp/PIN bias |
| 4   | Ground          |
| 5   | Ground          |
| 6   | RF Out          |
| 7   | Ground          |

# Package Information

The AFBR-2310Z Receiver is housed in a TO-46 header, joint to a robust FC plastic receptacle, as shown in Figure 3.

Figure 4 shows the mechanical outline of the flex.

A nut with washer is used to fix the receiver to the customer box wall. The aperture in the box wall should be designed to avoid rotation of the receptacle.

A dust cap is provided for shipping and should be used whenever the receiver is not connected to a fiber patch cord.

**Figure 3: Mechanical Layout of Analog Receiver. The flex is shown before bending. All dimensions are in mm.**

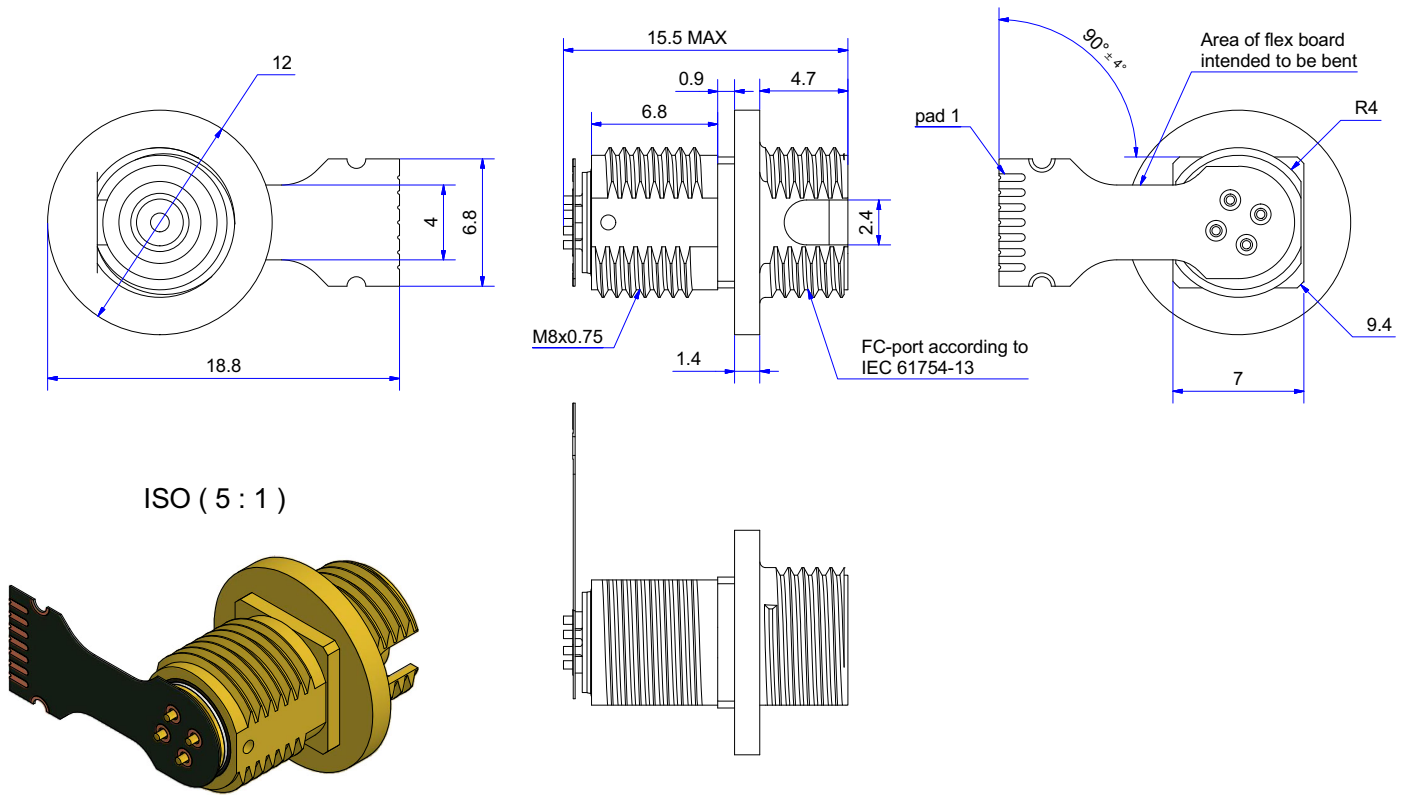

Figure 4: Flex Outline. All dimensions are in mm.

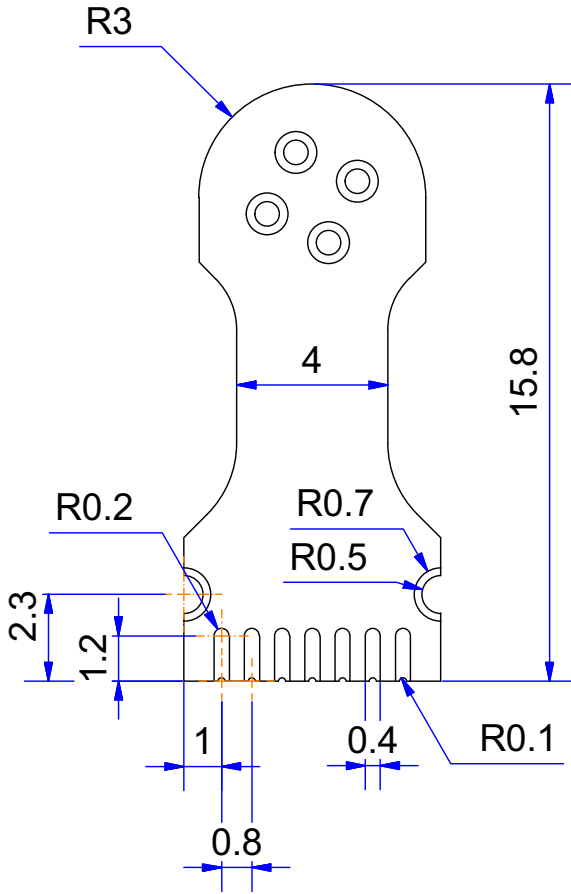
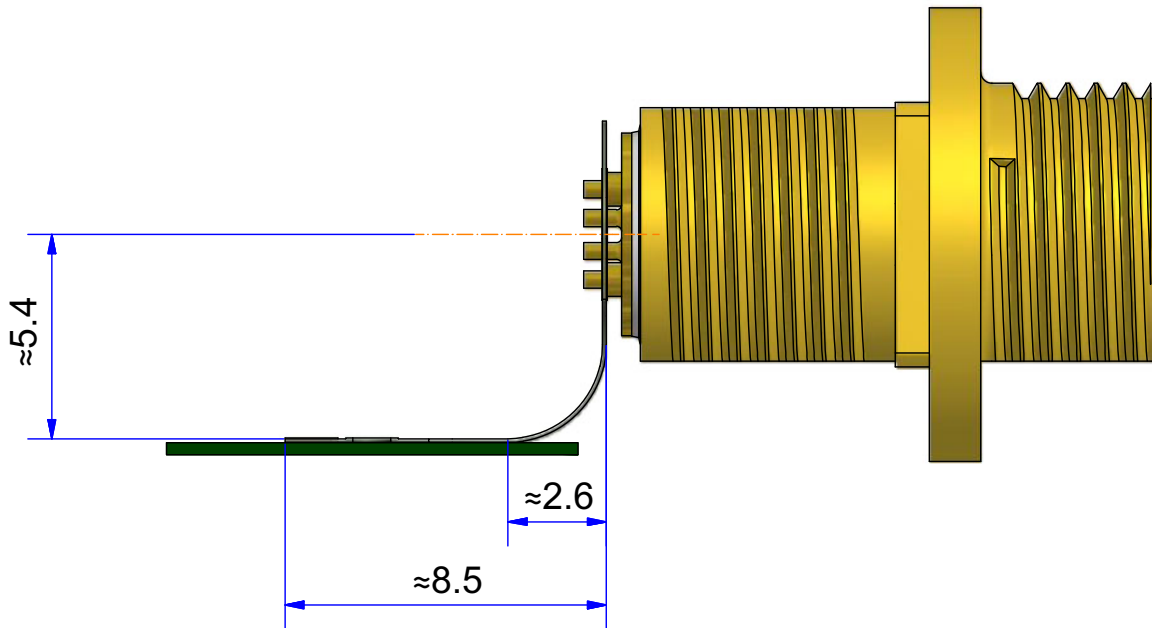

Figure 5: Example of Flex Bending when Soldered onto a PCB. All dimensions are in mm.



## Handling Information

When soldering the flex to the customer PCB, avoid heating or touching with the hot iron the plastic receptacle and the header to flex interconnections.

The flex circuit can be soldered to the customer PCB by hand soldering or with automatic equipment (like a hot bar).

Use a washless flux to solder the flex pads to the PCB.

This device is sensitive to ESD discharge. To protect the device, use normal ESD handling precautions. These include using grounded wrist straps, work-benches, and floors wherever a receiver is handled.

## Mounting Hardware

A nut with integrated washer is used to assemble the receiver to a panel (see Figure 6).

Recommended Application Circuit

Figure 7 shows the recommended application circuit.

Proper 50Ω controlled impedance traces are required on the RF output. The RF output must be AC coupled to the next amplifier stage.

The RF amp/PIN bias pads should be connected to a 8.2Ω impedance controlled trace, terminated with a 8.2Ω resistor in parallel to an inductor. Filtering caps are required on the bias line.

Figure 6: Mechanical Dimensions of the Nut + Washer. All dimensions are in mm.

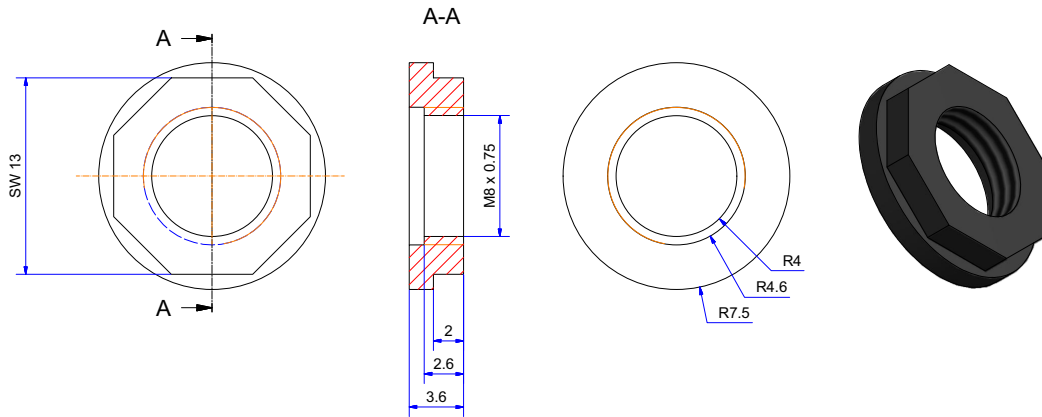
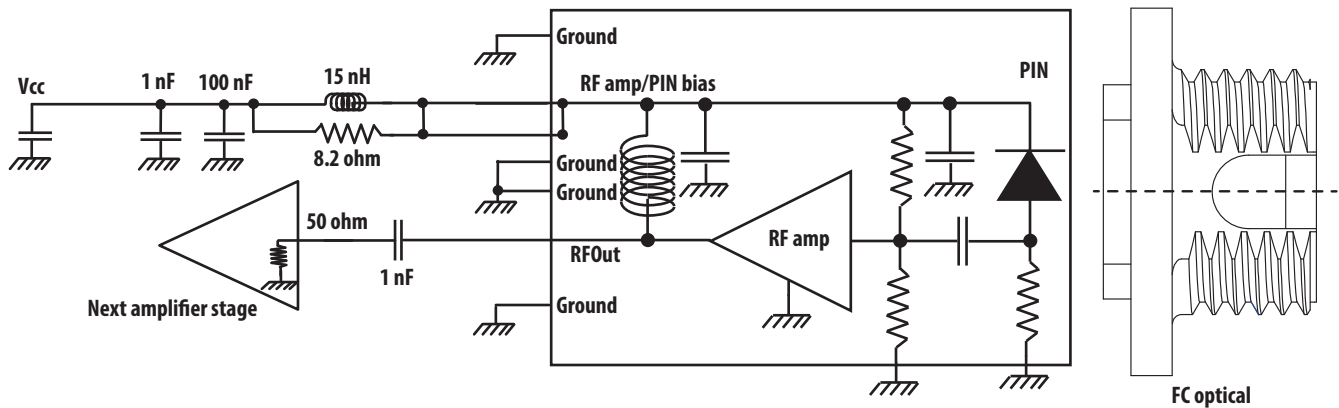

Figure 7: Recommended Application Circuit



Broadcom, the pulse logo, Connecting everything, Avago Technologies, Avago, and the A logo are among the trademarks of Broadcom and/or its affiliates in the United States, certain other countries and/or the EU.

Copyright © 2011–2018 Broadcom. All Rights Reserved.

The term “Broadcom” refers to Broadcom Inc. and/or its subsidiaries. For more information, please visit [www.broadcom.com](http://www.broadcom.com).

Broadcom reserves the right to make changes without further notice to any products or data herein to improve reliability, function, or design. Information furnished by Broadcom is believed to be accurate and reliable. However, Broadcom does not assume any liability arising out of the application or use of this information, nor the application or use of any product or circuit described herein, neither does it convey any license under its patent rights nor the rights of others.

