

TOSHIBA Bipolar Linear Integrated Circuit Silicon Monolithic

TA7368P, TA7368F

Audio Power Amplifier

The TA7368P and TA7368F are suitable for the audio power amplifier of portable cassette tape recorder and radio.

Features

- Very few external parts (only three capacitors)
- Low quiescent current: $I_{CCQ} = 6.6\text{mA (typ.) (}V_{CC} = 6\text{V)}$
- Output power
 TA7368P
 : $P_{out} = 720\text{mW (typ.) (}V_{CC} = 6\text{V, }R_L = 4\Omega, \text{THD} = 10\%)$
 TA7368P / F
 : $P_{out} = 450\text{mW (typ.) (}V_{CC} = 6\text{V, }R_L = 8\Omega, \text{THD} = 10\%)$
- Voltage gain: $G_V = 40\text{dB (typ.)}$
- Operating supply voltage range: $V_{CC} = 2\sim 10\text{V (}T_a = 25^\circ\text{C)}$

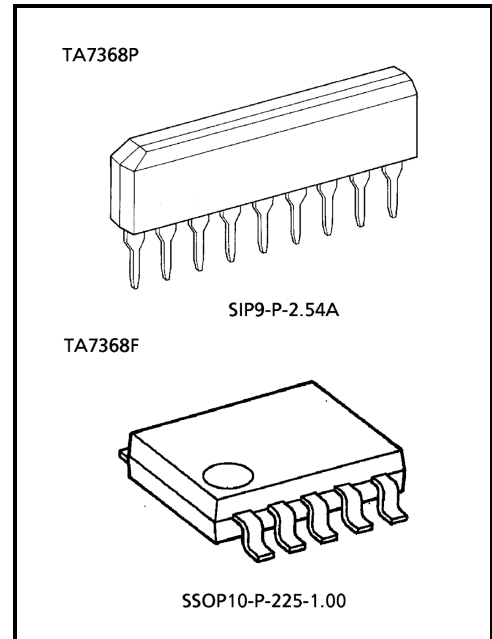

Weight
 SIP9-P-2.54A : 0.92g (typ.)
 SSOP10-P-225-1.00 : 0.09g (typ.)

Block Diagram

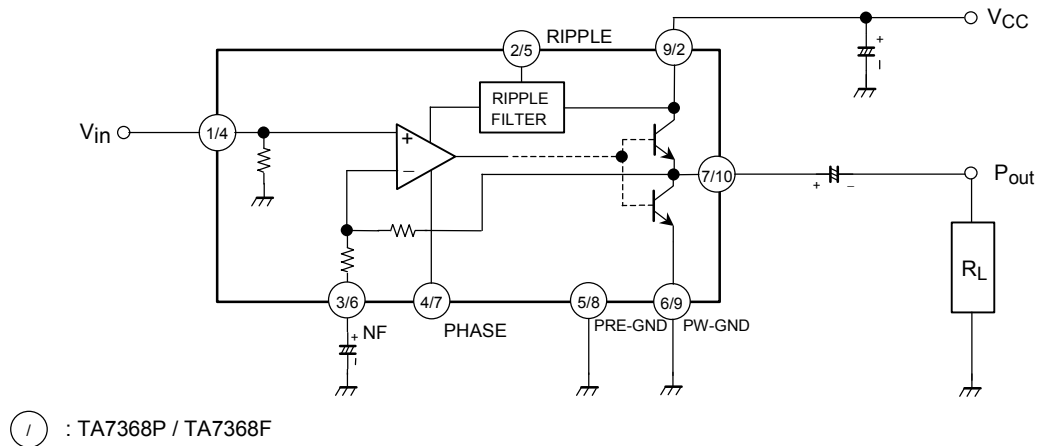

Precaution For Use And Application

1. Input stage

The input stage of power amplifier (equivalent circuit) is comprised of a PNP differential pair (Q₂ and Q₃) preceded by a PNP emitter follower (Q₁) which allows DC referencing of the source signal to ground. This eliminated the need for an input coupling capacitor. However, in case the brush noise of volume becomes a problem, provide serially a coupling capacitor to the input side.

2. Adjustment of voltage gain

The voltage gain is fixed at $G_V \approx 40\text{dB}$ by the resistors (R₄ and R₅) in IC, however, its reduction is possible through adding R_f as shown in Figure 2. In this case, the voltage gain is obtained by the following equation.

$$G_V = 20 \log \frac{R_5 + R_4 + R_f}{R_4 + R_f}$$

It is recommended to use this IC with the voltage gain of $G_V = 28\text{dB}$ or over.

3. Ripple rejection ratio

Adding CRIP, to ripple terminal 2 as shown in Figure 3, the ripple rejection ratio is improved from -25dB typ. to -45dB typ.

4. Power dissipation

Care should be taken to use this IC below maximum power dissipation. Because it may over maximum rating depending on operating condition.

- TA7368P $P_D = 900\text{mW}$ ($T_a = 25^\circ\text{C}$)
- TA7368F $P_D = 400\text{mW}$ ($T_a = 25^\circ\text{C}$)

5. Phase-compensation

Small temperature coefficient and excellent frequency characteristic is needed by capacitors below.

- Oscillation preventing capacitors for power amplifier output
- Bypass capacitor for ripple filter
- Capacitor between VCC and GND

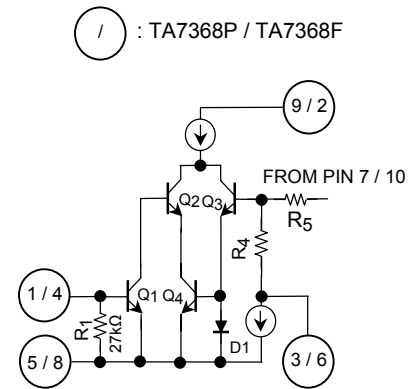

Fig.1

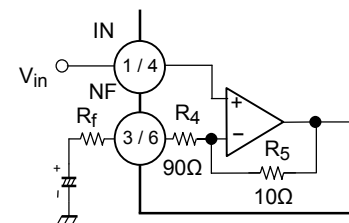

Fig.2

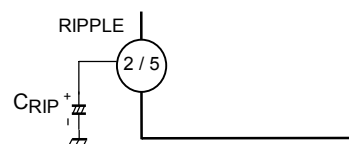

Fig.3

Maximum Ratings (Ta = 25°C)

Characteristic	Symbol	Rating	Unit
Supply voltage	V _{CC}	14	V
Power dissipation	TA7368P	P _D (Note)	900
	TA7368F		400
Operating temperature	T _{opr}	-25~75	°C
Storage temperature	T _{stg}	-55~150	°C

(Note) Derated above Ta = 25°C in the proportion of 7.2mW / °C for TA7368P and of 3.2mW / °C for TA7368F.

Electrical Characteristics For TA7368P

(Unless otherwise specified, V_{CC} = 6V, f = 1kHz, R_g = 600Ω, R_L = 4Ω, Ta = 25°C)

Characteristic	Symbol	Test Circuit	Test Condition	Min.	Typ.	Max.	Unit
Quiescent current	I _{CCQ}	—	V _{CC} = 3V, V _{in} = 0	—	5.5	—	mA
			V _{CC} = 6V, V _{in} = 0	—	6.6	15	
			V _{CC} = 9V, V _{in} = 0	—	7.5	18	
Output power	P _{out}	—	V _{CC} = 3V, R _L = 4Ω, THD = 10%	—	120	—	mW
			V _{CC} = 6V, R _L = 4Ω, THD = 10%	500	720	—	
			V _{CC} = 6V, R _L = 8Ω, THD = 10%	300	450	—	
			V _{CC} = 9V, R _L = 8Ω, THD = 10%	800	1100	—	
			V _{CC} = 9V, R _L = 16Ω, THD = 10%	450	610	—	
Total harmonic distortion	THD	—	P _{out} = 100mW	—	0.3	1.0	%
Voltage gain	G _V	—	V _{in} = 0.5mV _{rms}	37	40	43	dB
Output noise voltage	V _{no}	—	R _g = 10kΩ, BPF = 20Hz~20kHz	—	0.2	0.5	mV _{rms}
Ripple rejection ratio	RR	—	f _r = 100Hz, V _r = 0.3V _{rms} Without C _{RIP}	—	25	—	dB
Input resistance	R _{IN}	—	—	—	27	—	kΩ

Terminal Voltage For TA7368P

Typical Terminal Voltage at no Signal With Test Circuit. (V_{CC} = 6V, Ta = 25°C) [Unit: V]

Terminal no.	1	2	3	4	5	6	7	8	9
DC voltage (V)	0	2.40	0.62	0.64	0	0	2.61	NC	6.0

Electrical Characteristic For TA7368F

(unless otherwise specified, $V_{CC} = 6V$, $f = 1kHz$, $R_g = 600\Omega$, $R_L = 8\Omega$, $T_a = 25^\circ C$)

Characteristic	Symbol	Test Circuit	Test Condition	Min.	Typ.	Max.	Unit
Quiescent current	I_{CCQ}	—	$V_{CC} = 3V, V_{in} = 0$	—	5.5	—	mA
			$V_{CC} = 6V, V_{in} = 0$	—	6.6	15	
			$V_{CC} = 9V, V_{in} = 0$	—	7.5	18	
Output power	P_{out}	—	$V_{CC} = 3V, R_L = 4\Omega, THD = 10\%$	—	120	—	mW
			$V_{CC} = 6V, R_L = 8\Omega, THD = 10\%$	300	450	—	
			$V_{CC} = 9V, R_L = 16\Omega, THD = 10\%$	450	610	—	
Total harmonic distortion	THD	—	$P_{out} = 100mW$	—	0.3	1.0	%
Voltage gain	G_V	—	$V_{in} = 0.5mV_{rms}$	37	40	43	dB
Output noise voltage	V_{no}	—	$R_g = 10k\Omega, BPF = 20Hz \sim 20kHz$	—	0.2	0.5	mV_{rms}
Ripple rejection ratio	RR	—	$f_r = 100Hz, V_r = 0.3V_{rms}$, Without C_{RIP}	—	25	—	dB
Input resistance	R_{IN}	—	—	—	27	—	$k\Omega$

Terminal Voltage For TA7368F

Typical Terminal Voltage at no Signal with Test Circuit. ($V_{CC} = 6V$, $T_a = 25^\circ C$)

[Unit: V]

Terminal no.	1	2	3	4	5	6	7	8	9	10
DC voltage (V)	NC	6.0	NC	0	2.40	0.62	0.64	0	0	2.61

Test Circuit

TA7368P

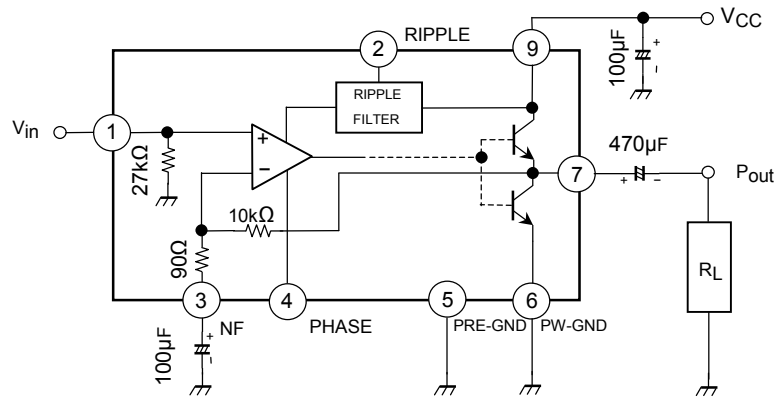

※ Pin(8): Non-connection

TA7368F

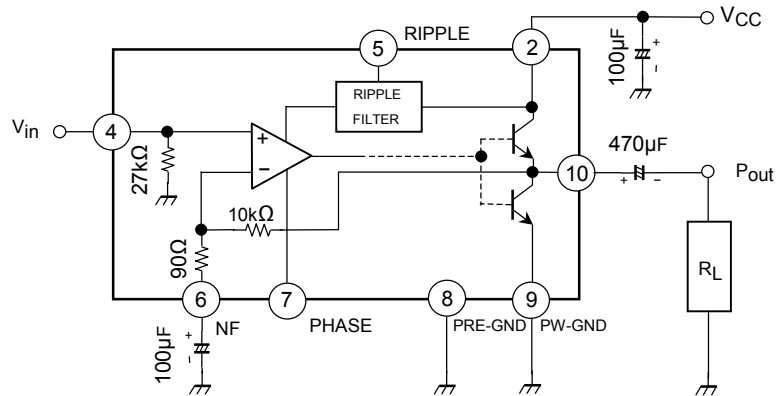

※ Pin(1), (3): Non-connection

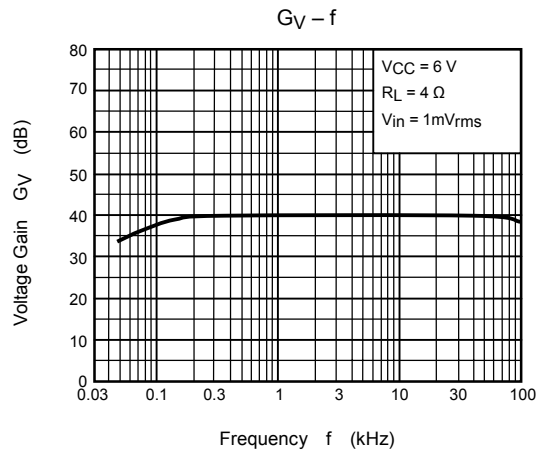
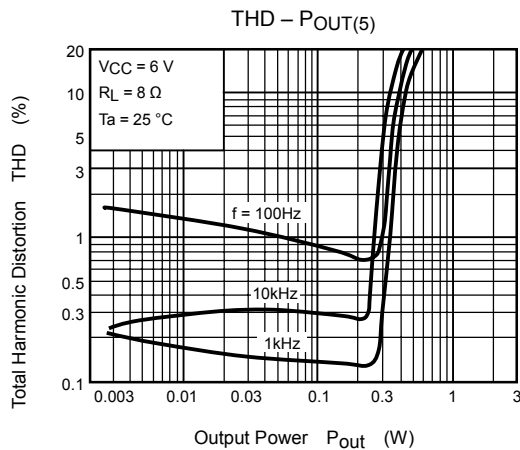
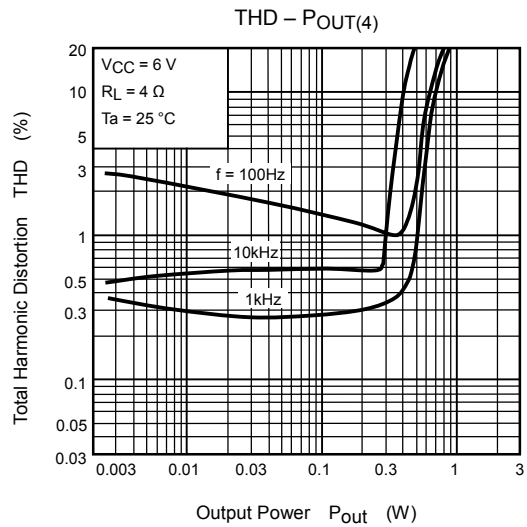
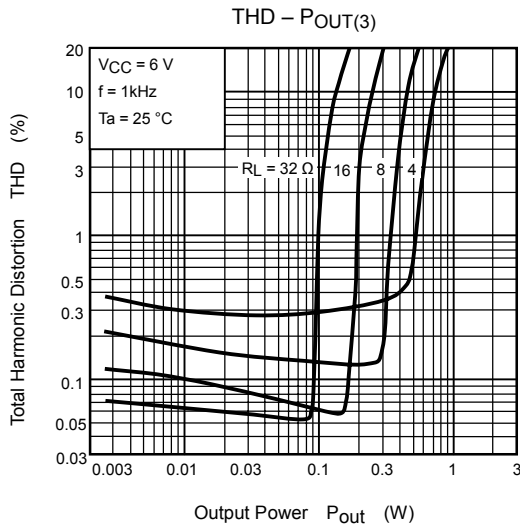
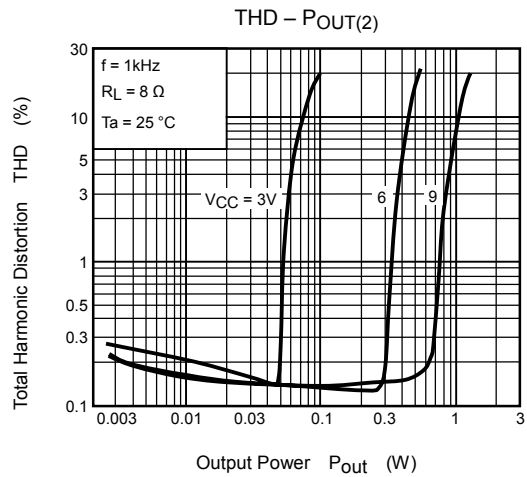
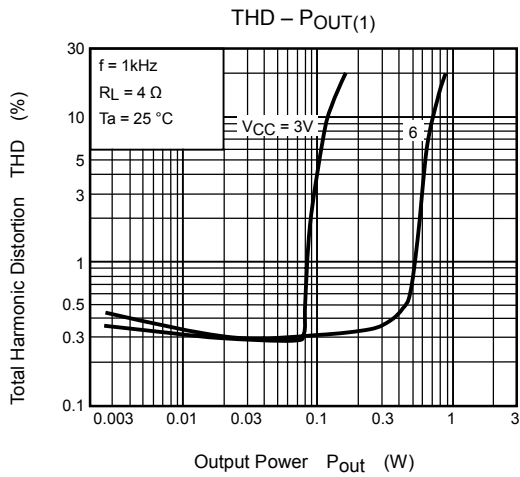

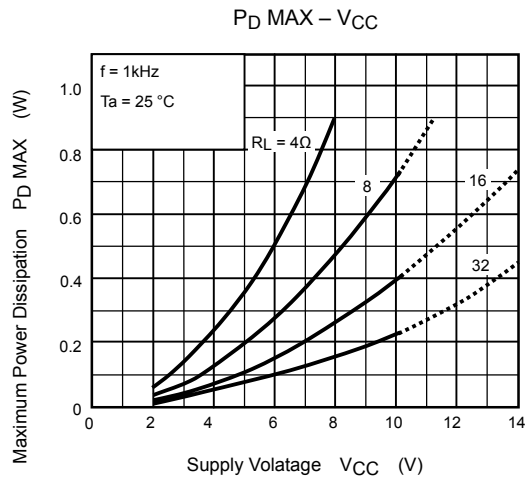
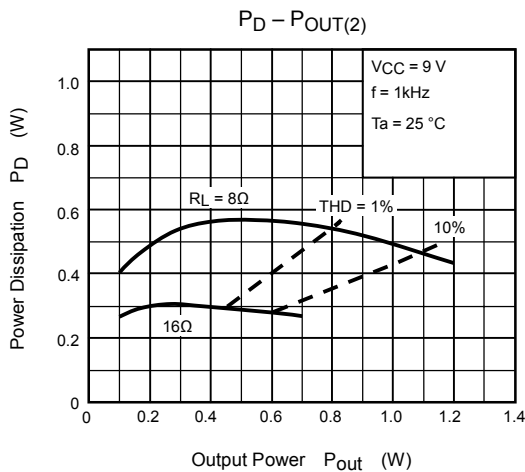
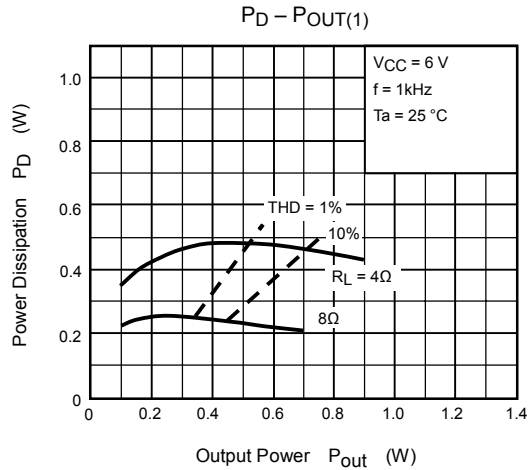
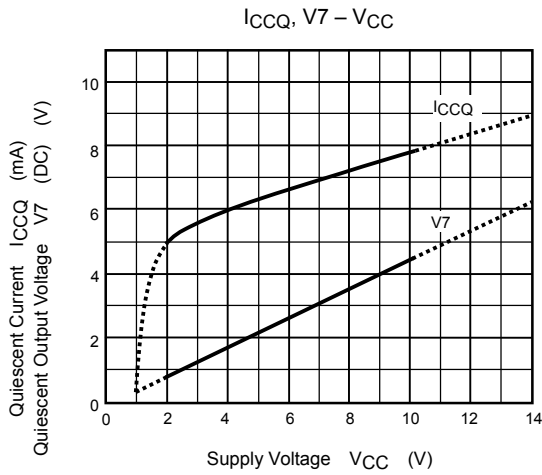
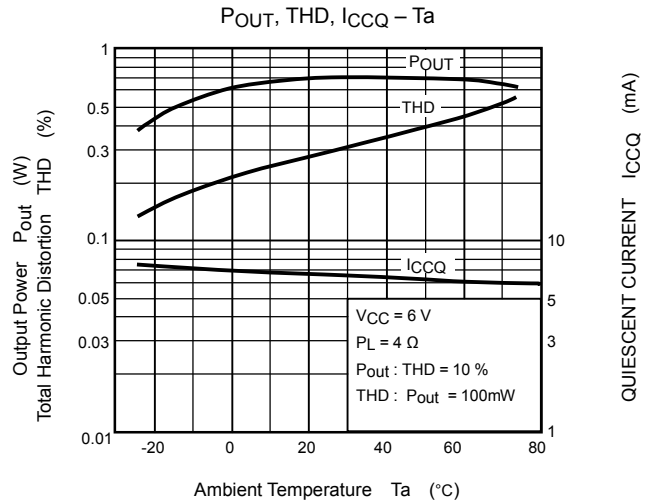
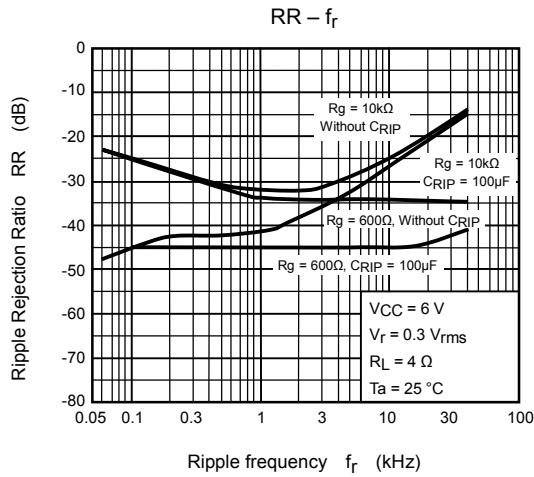

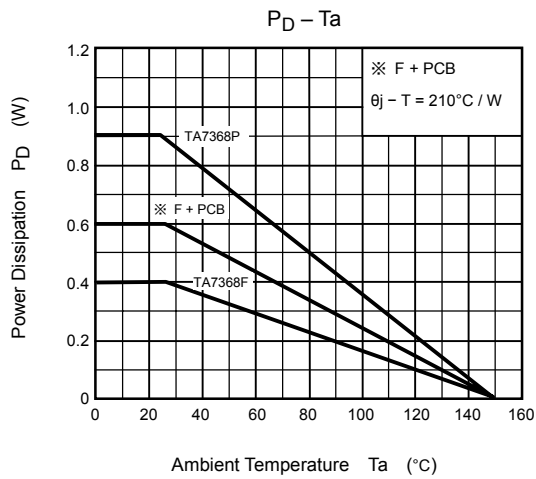

※ F+PCB
 By being mounted on certain PCB's, flat packages increase the heat dissipating efficiency.
 Data shown on the left is resulted from the measurement on the PCB recommended by TOSHIBA.
 ($\theta_j - T$: Thermal resistance)

Printed Circuit Board

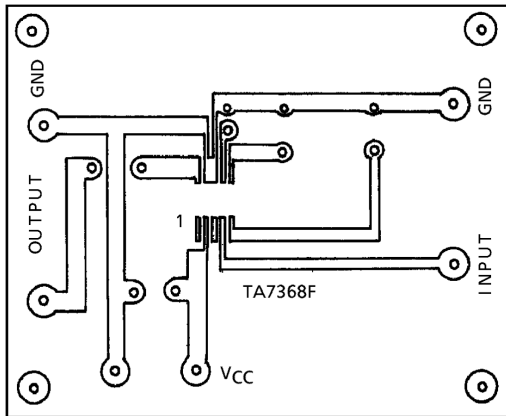

Material: Phenol resin
 Thickness of copper leaf: 35 μ m
 Plate thickness: 1.6mm

60 x 47.5 (mm)

Package Dimensions

SIP9-P-2.54A

Unit : mm

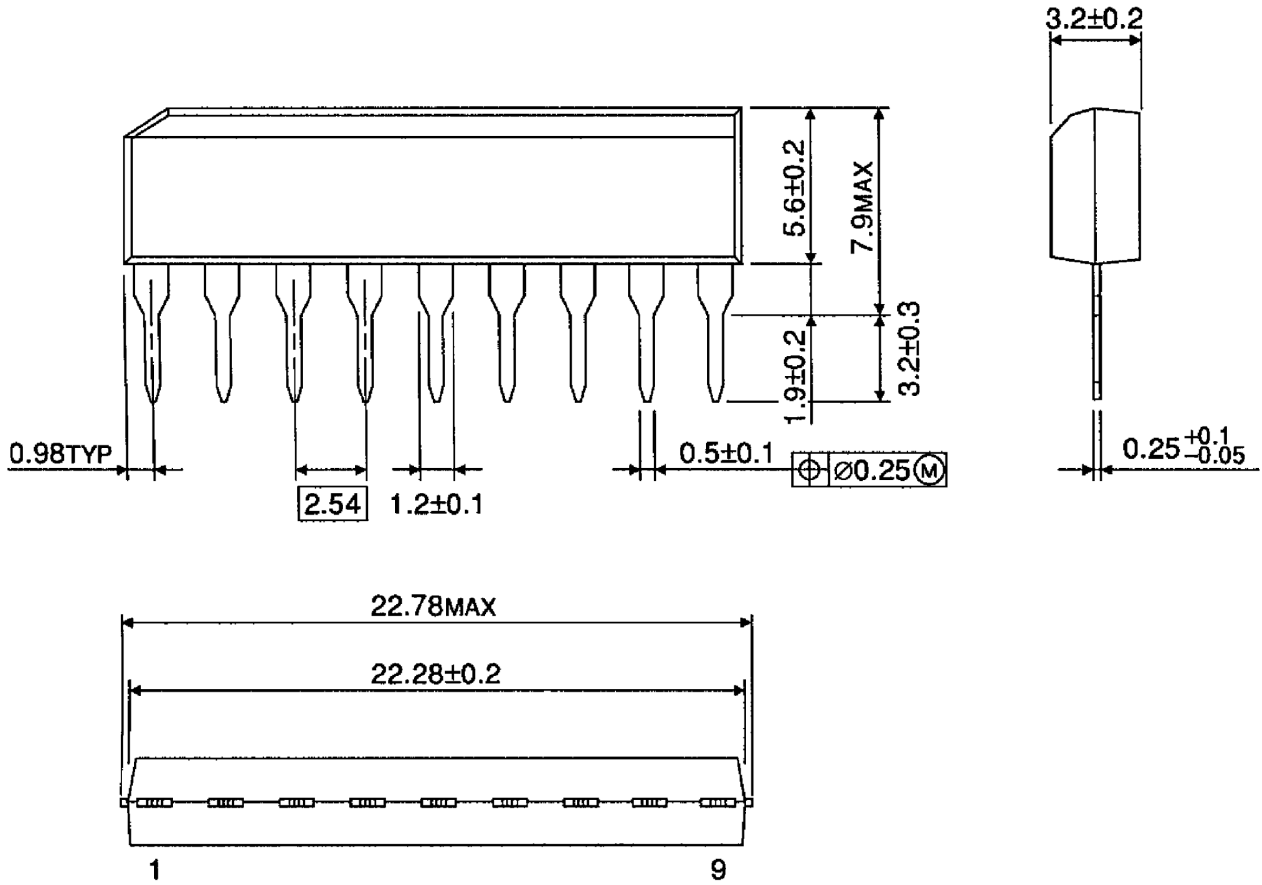

Weight: 0.92g (typ.)

Package Dimensions

SSOP10-P-225-1.00

Unit : mm

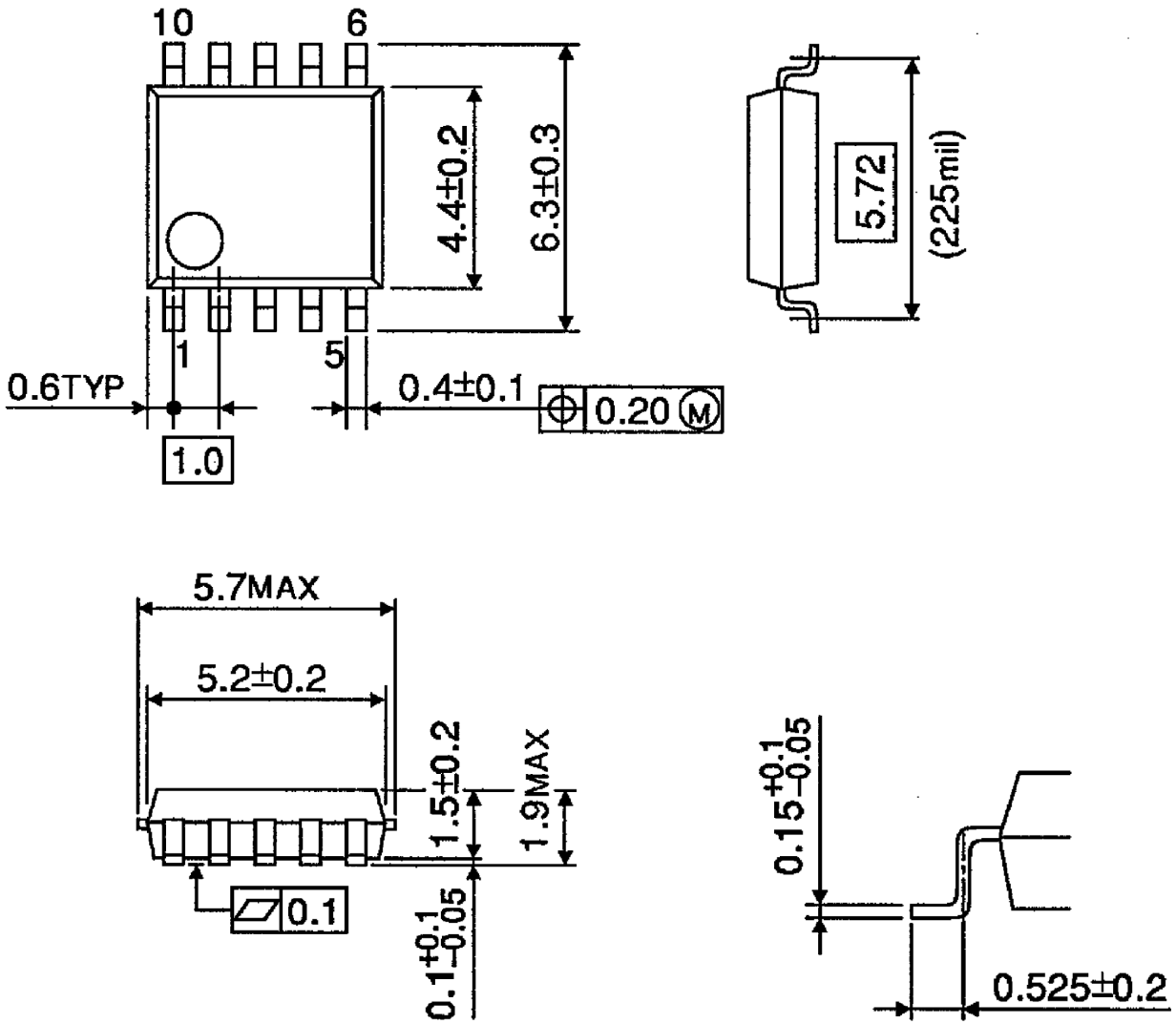

Weight: 0.09g (typ.)

RESTRICTIONS ON PRODUCT USE

000707EBA

- TOSHIBA is continually working to improve the quality and reliability of its products. Nevertheless, semiconductor devices in general can malfunction or fail due to their inherent electrical sensitivity and vulnerability to physical stress. It is the responsibility of the buyer, when utilizing TOSHIBA products, to comply with the standards of safety in making a safe design for the entire system, and to avoid situations in which a malfunction or failure of such TOSHIBA products could cause loss of human life, bodily injury or damage to property.
In developing your designs, please ensure that TOSHIBA products are used within specified operating ranges as set forth in the most recent TOSHIBA products specifications. Also, please keep in mind the precautions and conditions set forth in the "Handling Guide for Semiconductor Devices," or "TOSHIBA Semiconductor Reliability Handbook" etc..
- The TOSHIBA products listed in this document are intended for usage in general electronics applications (computer, personal equipment, office equipment, measuring equipment, industrial robotics, domestic appliances, etc.). These TOSHIBA products are neither intended nor warranted for usage in equipment that requires extraordinarily high quality and/or reliability or a malfunction or failure of which may cause loss of human life or bodily injury ("Unintended Usage"). Unintended Usage include atomic energy control instruments, airplane or spaceship instruments, transportation instruments, traffic signal instruments, combustion control instruments, medical instruments, all types of safety devices, etc.. Unintended Usage of TOSHIBA products listed in this document shall be made at the customer's own risk.
- The products described in this document are subject to the foreign exchange and foreign trade laws.
- The information contained herein is presented only as a guide for the applications of our products. No responsibility is assumed by TOSHIBA CORPORATION for any infringements of intellectual property or other rights of the third parties which may result from its use. No license is granted by implication or otherwise under any intellectual property or other rights of TOSHIBA CORPORATION or others.
- The information contained herein is subject to change without notice.

This datasheet has been download from:

www.datasheetcatalog.com

Datasheets for electronics components.