

LM1889 TV Video Modulator

General Description

The LM1889 is designed to interface audio, color difference, and luminance signals to the antenna terminals of a TV receiver. It consists of a sound subcarrier oscillator, chroma subcarrier oscillator, quadrature chroma modulators, and RF oscillators and modulators for two low-VHF channels.

The LM1889 allows video information from VTR's, games, test equipment, or similar sources to be displayed on black and white or color TV receivers. When used with the MM57100 and MM53104, a complete TV game is formed.

Features

- dc channel switching
- 12V to 18V supply operation
- Excellent oscillator stability
- Low intermodulation products
- 5 Vp-p chroma reference signal
- May be used to encode composite video

Block Diagram

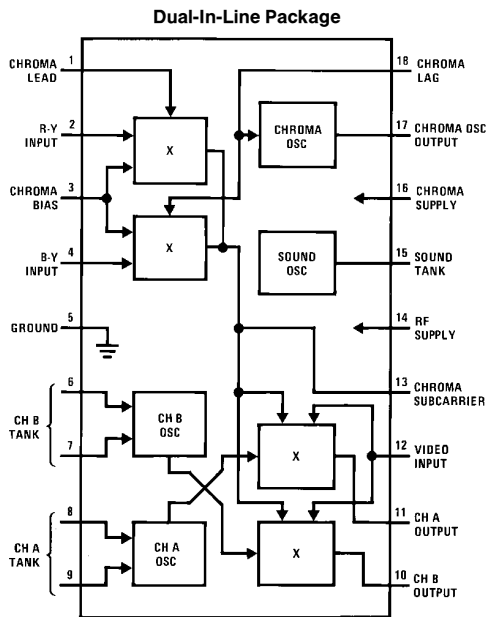

TL/H/7917-1

Order Number LM1889N
See NS Package Number N18A

DC Test Circuit

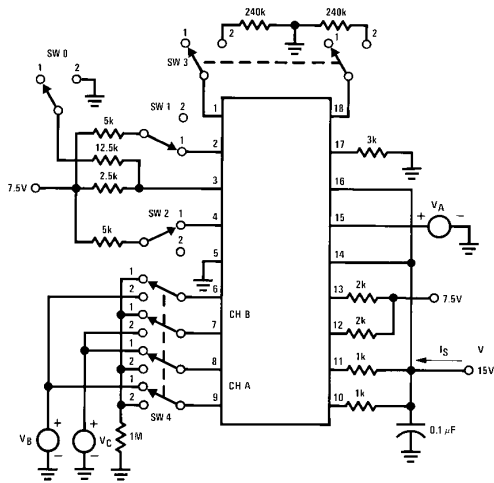

TL/H/7917-2

Absolute Maximum Ratings

If Military/Aerospace specified devices are required, please contact the National Semiconductor Sales Office/Distributors for availability and specifications.

Supply Voltage V14, V16 max	19 V _{DC}	Storage Temperature Range	-55°C to +150°C
Power Dissipation Package (Note 1)	1800 mW	Chroma Osc Current I ₁₇ max	10 mA _{DC}
Operating Temperature Range	0°C to +70°C	(V16-V15) max	±5 V _{DC}
		(V14-V10) max	7V
		(V14-V11) max	7V
		Lead Temperature (Soldering, 10 sec.)	260°C

DC Electrical Characteristics (dc Test Circuit, All SW Normally Pos. 1, V_A = 15V, V_B = V_C = 12V)

Symbol	Parameter	Conditions	Min	Typ	Max	Units
I _S	Supply Current		20	35	45	mA
ΔI ₁₅	Sound Oscillator, Current Change	Change V _A from 12.5 to 17.5V	0.3	0.6	0.9	mA
V17	Chroma Oscillator Balance		9.5	11.0	12.5	V
V13	Chroma Modulator Balance		7.0	7.4	7.8	V
ΔV13	R-Y Modulator Output Level	SW 3, Pos. 2, Change SW 1 from Pos. 1 to Pos. 2	0.6	0.9	1.2	V
ΔV13	B-Y Modulator Output Level	SW 3, Pos. 2, Change SW 2 from Pos. 1 to Pos. 2	0.6	0.9	1.2	V
ΔV13/ΔV3	Chroma Modulator Conversion Ratio	SW 3, Pos. 2, Change SW 0 from Pos. 1 to Pos. 2 Divide ΔV13 by ΔV3	0.45	0.70	0.95	V/V
V8, V9	Ch. A Oscillator "OFF" Voltage	SW 4, Pos. 2		1.0	3.0	V
I _g	Ch. A Oscillator Current Level	V _B = 12V, V _C = 13V	3.0	4.0	5.5	mA
V6, V7	Ch. B Oscillator "OFF" Voltage			1.0	3.0	V
I ₆	Ch. B Oscillator Current Level	SW 4, Pos. 2, V _B = 12V, V _C = 13V	3.0	4.0	5.5	mA
ΔV11/(V13-V12)	Ch. A Modulator Conversion Ratio	SW 1, SW2, SW 3, Pos. 2, Measure ΔV11(V10) by Changing from V _B = 12.5V, V _C = 11.5V to V _B = 11.5V, V _C = 12.5V and Divide by V13-V12	0.35	0.55	0.75	V/V
ΔV10/(V13-V12)	Ch. B Modulator Conversion Ratio	Divide as Above	0.35	0.55	0.75	V/V

AC Electrical Characteristics (AC Test Circuit, V = 15V)

Symbol	Parameter	Conditions	Min	Typ	Max	Units
V17	Chroma Oscillator Output Level	C _{LOAD} ≤ 20 pF	4	5		Vp-p
V15	Sound Carrier Oscillator Level	Loaded by RC Coupling Network	2	3	4	Vp-p
V8, V9	Ch. 3 RF Oscillator Level	Ch. SW. Pos. 3, f = 61.25 MHz, Use FET Probe	200	350		mVp-p
V6, V7	Ch. 4 RF Oscillator Level	Ch. Sw. Pos. 4, f = 67.25 MHz Use FET Probe	200	350		mVp-p

Note 1: For operation in ambient temperatures above 25°C, the device must be derated based on a 150° maximum junction temperature and a thermal resistance of 70°C C/W junction to ambient.

Design Characteristics (AC Test Circuit, V = 15V)

Parameter	Typ	Units	Parameter	Typ	Units
Oscillator Supply Dependence			RF Modulator		
Chroma, $f_o = 3.579545$ MHz	3	Hz/V	Conversion Gain, $f = 61.25$ MHz,		
Sound Carrier, RF	See Curves		$V_{OUT}/(V13-V12)$	10	mVrms/V
Oscillator Temperature Dependence (IC Only)			3.58 MHz Differential Gain	5	%
Chroma	0.05	ppm/°C	Differential Phase	3	degrees
Sound Carrier	-15	ppm/°C	2.5 Vp-p Video, 87.5% mod.		
RF	-50	ppm/°C	Output Harmonics below Carrier		
Chroma Oscillator Output, Pin 17			2nd, 3rd	-12	dB
t_{RISE} , 10-90%	20	ns	4th and above	-20	dB
t_{FALL} , 90-10%	30	ns	Input Impedances		
Duty Cycle (+) Half Cycle	51	%	Chroma Modulator, Pins 2, 4	500k//2 pF	
(-) Half Cycle	49	%	RF Modulator, Pin 12	1M//2 pF	
RF Oscillator Maximum Operating Frequency	100	MHz	Pin 13	250k//3.5 pF	
(Temperature Stability Degraded)					
Chroma Modulator ($f = 3.58$ MHz)					
B-Y Conversion Gain $V13/(V4-V3)$	0.6	Vp-p/V			
R-Y Conversion Gain $V13/(V2-V3)$	0.6	Vp-p/V			
Gain Balance	± 0.5	dB			
Bandwidth	See Curve				

AC Test Circuit

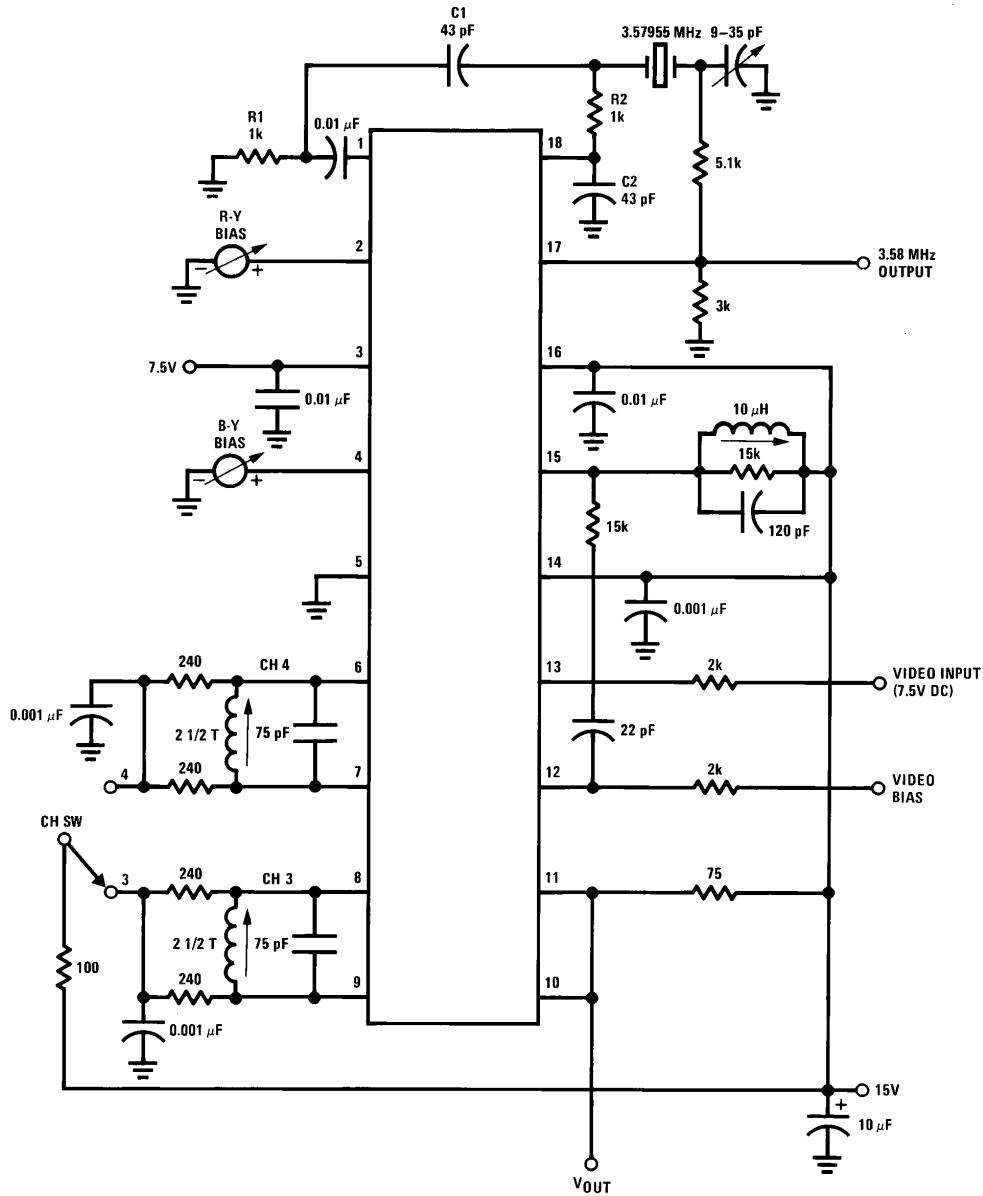

TL/H/7917-3

Typical Performance Characteristics

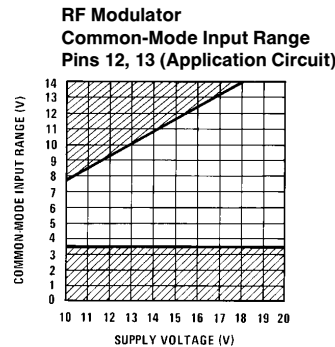
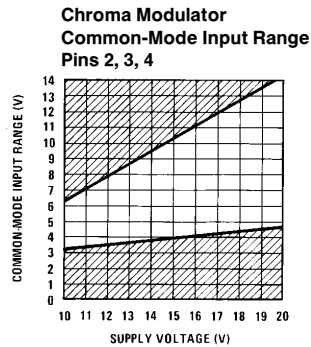
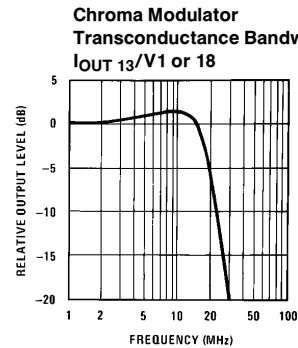
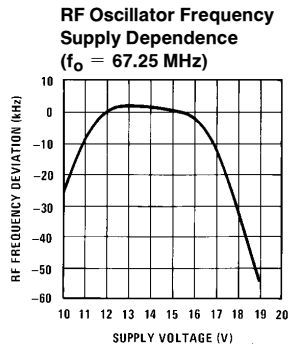
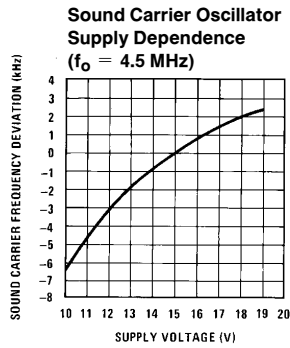

TL/H/7917-4

Circuit Description (Refer to Circuit Diagram)

The sound carrier oscillator is formed by differential amplifier Q3, Q4 operated with positive feedback from the pin 15 tank to the base of Q4.

The chroma oscillator consists of the inverting amplifier Q16, Q17 and Darlington emitter follower Q11, Q12. An external RC and crystal network from pin 17 to pin 18 provides an additional 180 degrees phase lag back to the base of Q17 to produce oscillation at the crystal resonance frequency. (See AC test circuit).

The feedback signal from the crystal is split in a lead-lag network to pins 1 and 18, respectively, to generate the sub-carrier reference signals for the chroma modulators. The R-Y modulator consists of multiplier devices Q29, Q30 and Q21-Q24, while the B-Y modulator consists of Q31, Q32 and Q25-Q28. The multiplier outputs are coupled through a balanced summing amplifier Q37, Q38 to the input of the RF modulators at pin 13. With 0 offset at the lower pairs of the multipliers, no chroma output is produced. However, when either pin 2 or pin 4 is offset relative to pin 3 a subcarrier output current of the appropriate phase is produced at pin 13.

The channel B oscillator consists of devices Q56 and Q57 cross-coupled through level-shift zener diodes Q54 and Q55. A current regulator consisting of devices Q39-Q43 is used to achieve good RF frequency stability over supply and temperature. The channel B modulator consists of multiplier devices Q58, Q59 and Q50-Q53. The top quad is coupled to the channel B tank through isolating devices Q48 and Q49. A dc offset between pins 12 and 13 offsets the lower pair to produce an output RF carrier at pin 10. That carrier is then modulated by both the chroma signal at pin 13 and the video and sound carrier signals at pin 12. The channel A modulator shares pin 12 and 13 buffers Q45 and Q44 with channel B and operates in an identical manner.

The current flowing through channel B oscillator diodes Q54, Q55 is turned around in Q60, Q61 and Q62 to source current for the channel B RF modulator. In the same manner, the channel A oscillator Q71-Q74 uses turn around Q77, Q78 and Q79 to source the channel A modulator. One oscillator at a time may be activated by connecting its tank to supply (see ac test circuit). The corresponding modulator is then activated by its current turn-around, and the other oscillator/modulator combination remains "OFF".

Circuit Diagram

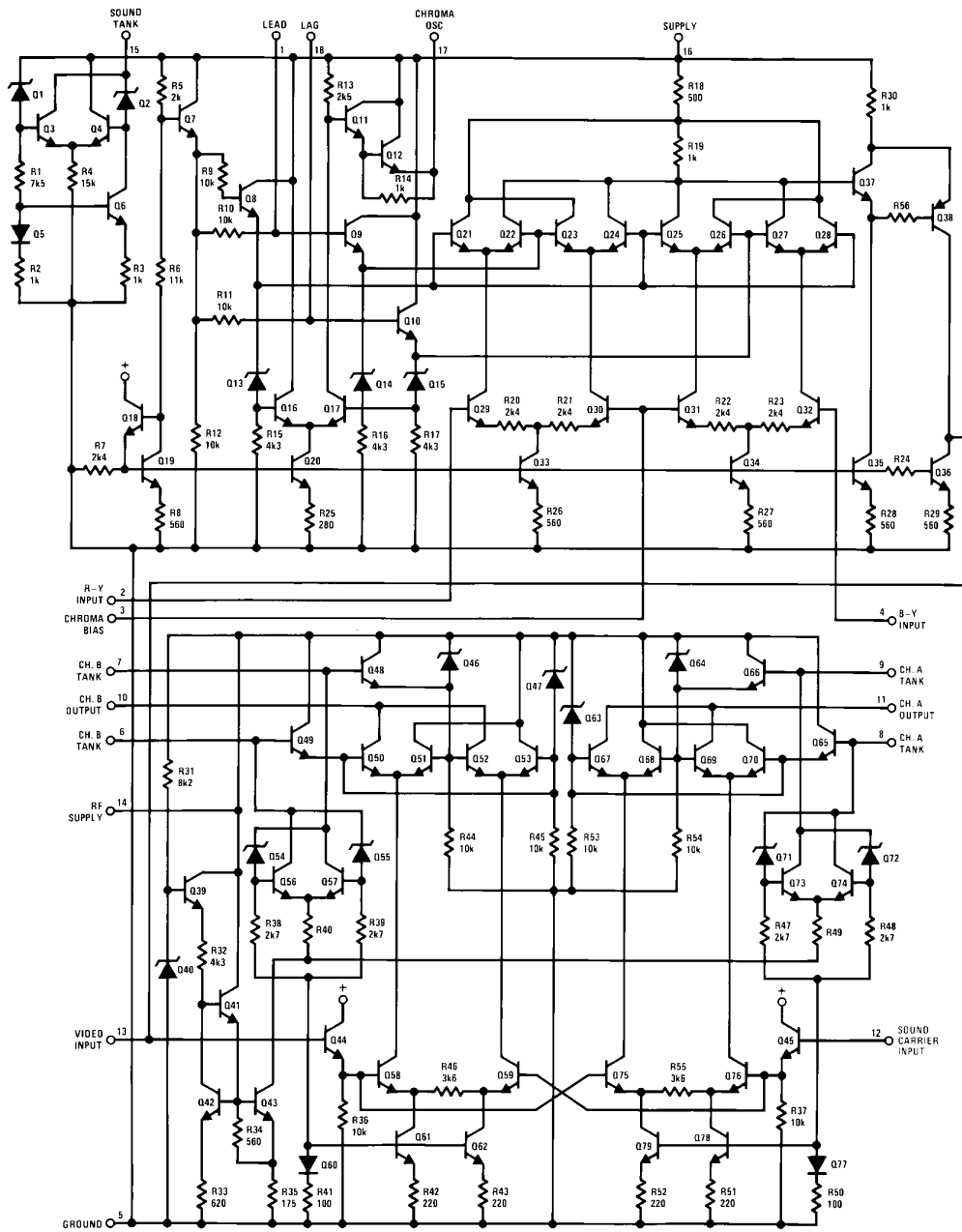

TL/H/7917-5

TV Game Schematic

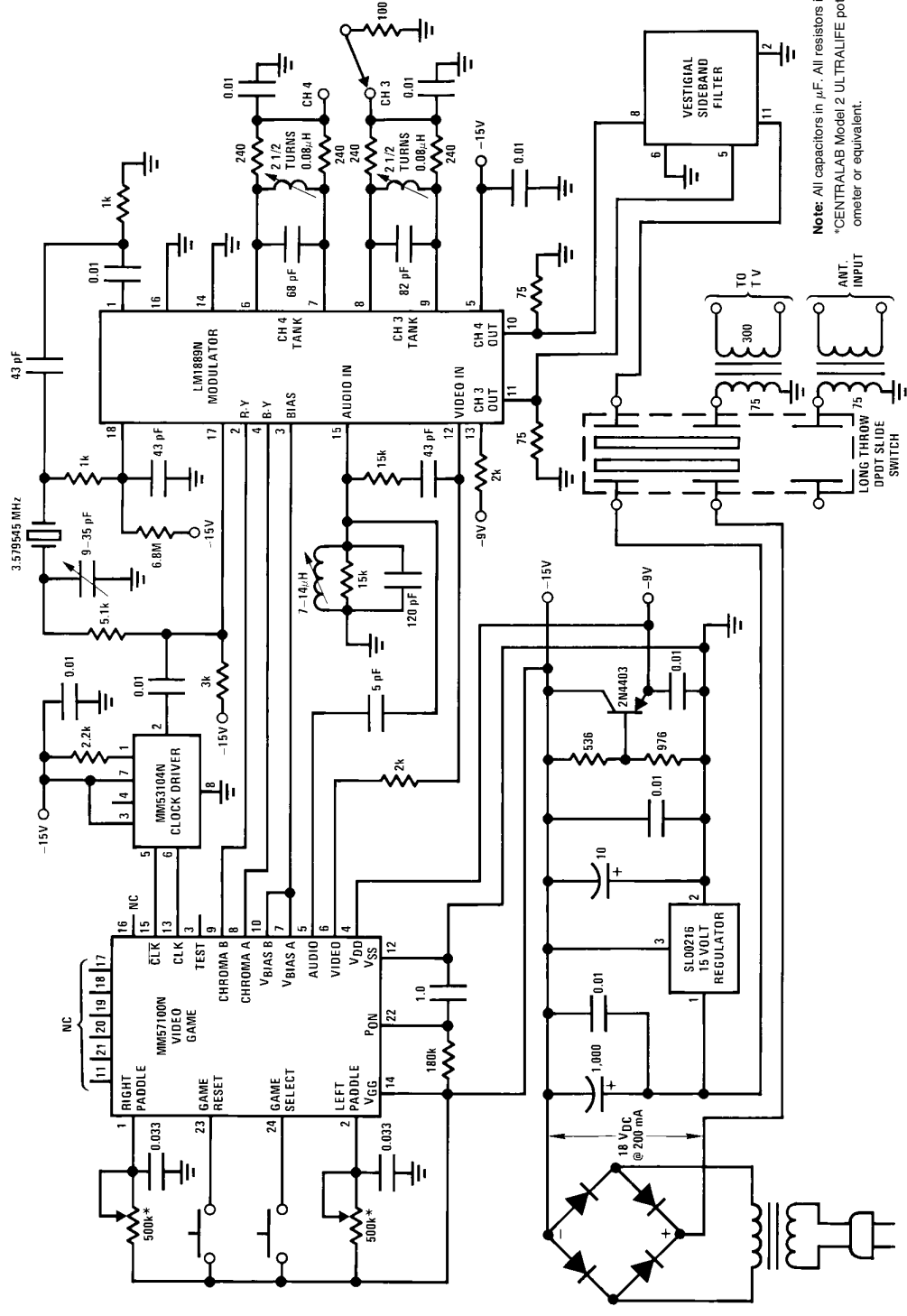

Note: All capacitors in μF . All resistors in Ω .
 *CENTRALAB Model 2 ULTRALIFE potentiometer or equivalent.

TL/H/7917-6

Applications Information

Subcarrier Oscillator

The oscillator is a crystal-controlled design to ensure the accuracy and stability required of the subcarrier frequency for use with television receivers. Lag-lead networks (R2C2 and C1R1) define a quadrature phase relationship between pins 1 and 18 at the subcarrier frequency of 3.579545 MHz. Other frequencies can be used and where high stability is not a requirement, the crystal can be replaced with a parallel resonant L-C tank circuit—to provide a 2 MHz clock, for example. Note that since one of the chrominance modulators is internally connected to the feedback path of the oscillator, operation of the oscillator at other than the correct subcarrier frequency precludes chrominance modulation.

When an external subcarrier source is available or preferred, this can be used instead. For proper modulator operation, a subcarrier amplitude of 500 mVp-p is required at pins 1 and 18. If the quadrature phase shift networks shown in the application circuit are retained, about 1 Vp-p subcarrier injected at the junction of C1 and R2 is sufficient. The crystal, C4 and R3 are eliminated and pin 17 provides a 5 Vp-p signal shifted +125°C from the external reference.

Chrominance Modulation

The simplest method of chroma encoding is to define the quadrature phases provided at pins 1 and 18 as the color difference axes R-Y and B-Y. A signal at pin 2 (R-Y) will give a chrominance subcarrier output from the modulator with a relative phase of 90°C compared to the subcarrier output produced by a signal at pin 4 (B-Y). The zero signal dc level of the R-Y and B-Y inputs will determine the bias level required at pin 3. For example, a pin 2 signal that is 1V positive with respect to pin 3 will give 0.6 Vp-p subcarrier at a relative phase of 90°C. If pin 2 is 1V negative with respect to pin 3, the output is again 0.6 Vp-p, but with a relative phase of 270°C. When a simultaneous signal exists at pin 4, the subcarrier output level and phase will be the vector sum of the quadrature components produced by pin 2 and 4 inputs. Clearly, with the modulation axes defined as above, a negative pulse on pin 4 during the burst gate period will produce the chrominance synchronizing “burst” with a phase of 180°. Both color difference signals must be dc coupled to the modulators and the zero signal dc level of both must be the same and within the common-mode range of the modulators.

The 0.6 Vp-p/V_{dc} conversion gain of the chrominance modulators is obtained with a 2 kΩ resistor connected at pin 13. Larger resistor values can be used to increase the gain, but capacitance at pin 13 will reduce the bandwidth. Notice that equi-bandwidth encoding of the color difference signals is implied as both modulator outputs are internally connected and summed into the same load resistor.

Sound Oscillator

Frequency modulation is achieved by using a 4.5 MHz tank circuit and deviating the center frequency via a capacitor or a varactor diode. Switching a 5 pF capacitor to ground at an audio frequency rate will cause a 50 kHz deviation from 4.5 MHz. A 1N5447 diode biased -4V from pin 16 will give ±20 kHz deviation with a 1 Vp-p audio signal. The coupling network to the video modulator input and the varactor diode bias must be included when the tank circuit is tuned to center frequency.

A good level for the RF sound carrier is between 2% and 20% of the picture carrier level. For example, if the peak video signal offset of pin 12 with respect to pin 13 is 3V, this corresponds to a 30 mVrms picture RF carrier. The source impedance at pin 12 is defined by the external 2 kΩ resistor and so a series network of 15 kΩ and 24 pF will give a sound carrier level at -32 dB to the picture carrier.

RF Modulation

Two RF channels are available, with carrier frequencies up to 100 MHz being determined by L-C tank circuits at pins 6, 7, 8 and 9. The signal inputs (pins 12, 13) to both modulators are common, but removing the power supply from an RF oscillator tank circuit will also disable that modulator.

As with the chrominance modulators, it is the offset between the two signal input pins that determines the level of RF carrier output. Since one signal input (pin 13) is also internally connected to the chrominance modulators, the 2 kΩ load resistor at this point should be connected to a bias source within the common-mode input range of the video modulators. However, this bias source is independent of the chrominance modulator bias and where chrominance modulation is not used, the 2 kΩ resistor is eliminated and the bias source connected directly to pin 13.

To preserve the dc content of the video signal, amplitude modulation of the RF carrier is done in one direction only, with increasing video (toward peak white) decreasing the carrier level. This means the active composite video signal at pin 12 must be offset with respect to pin 13 and the sync pulse should produce the largest offset (i.e., the offset voltage of pin 12 with respect to pin 13 should have the same polarity as the sync pulses).

The largest video signal (peak white) should not be able to suppress the carrier completely, particularly if sound transmission is needed. For example, a signal with 1V sync amplitude and 2.5V peak white (3.5 Vp-p, negative polarity sync) and a black level at 5 V_{dc} will require a dc bias of 8V on pin 13 for correct modulation. A simple way of obtaining the required offset is to bias pin 13 at 4 x (sync amplitude) from the sync tip level at pin 12.

Applications Information (Continued)

Split Power Supplies

The LM1889 is designed to operate over a wide range of supply voltages so that much of the time it can utilize the signal source power supplies. An example of this is shown in *Figure 2* where the composite video signal from a character generator is modulated onto an RF carrier for display on a conventional home TV receiver. The LM1889 is biased between the -12V and $+5\text{V}$ supplies and pin 13 is put at ground. A $9.1\text{ k}\Omega$ resistor from pin 12 to -12V dc offsets the video input signal (which has sync tips at ground) to establish the proper modulation depth — $R1/R2 = V_{IN}/12 \times 0.875$. This design is for monochrome transmission and features an extremely low external parts count.

DC Clamped Inputs

Utilizing a DC clamp will make matching the LM1889 to available signal generator outputs a simple process. *Figure 3* shows the LM1889 configured to accept the composite video patterns available from a Tektronix Type 144 generator that has black level at ground and negative polarity syncs. In this application, the chroma oscillator amplifier is used to provide a gain of two. The $100\text{ k}\Omega$ pot adjusts the overall DC level of the amplified signal which determines the modulation depth of the RF output. Clamping the input requires a minimum of DC correction to obtain the correct DC output level. This allows the adjustment to be a high impedance that will have minimum effect on the amplifier closed loop gain.

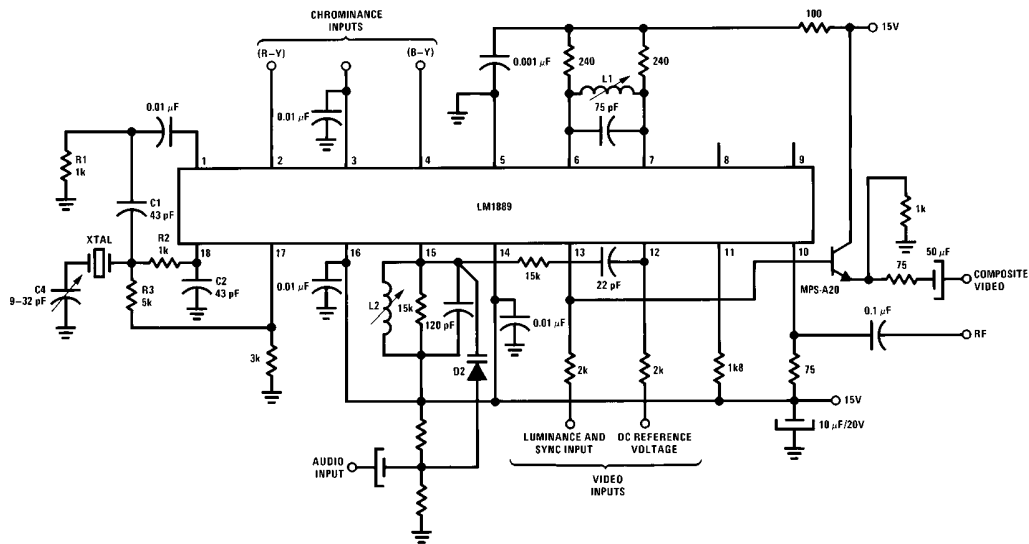

FIGURE 1. Luminance and Chrominance Encoding Composite Video or RF Output

TL/H/7917-7

Applications Information (Continued)

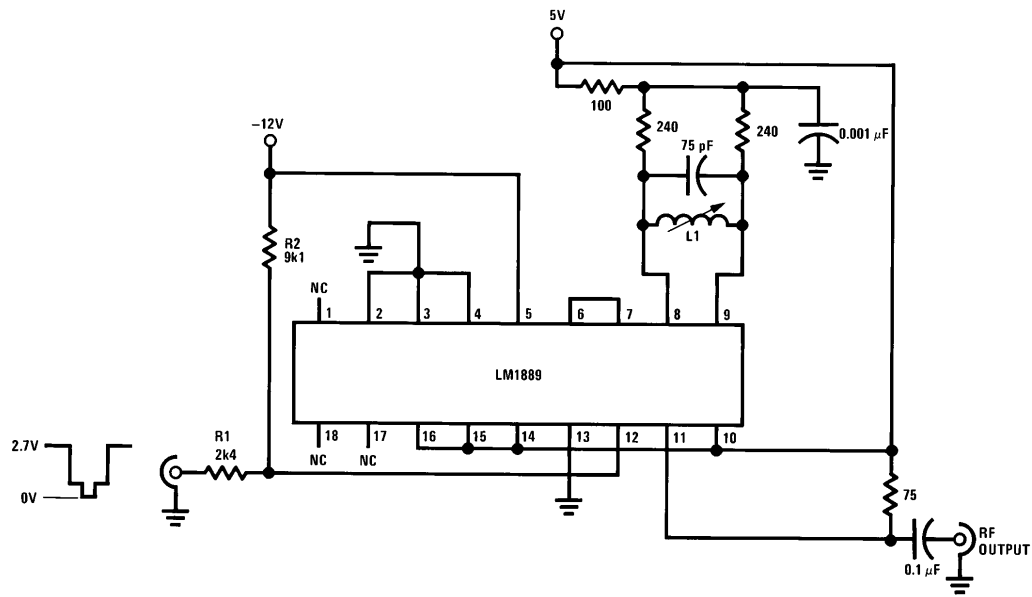

FIGURE 2. Low-Cost Monochrome Modulator for Character Generator Display

TL/H/7917-8

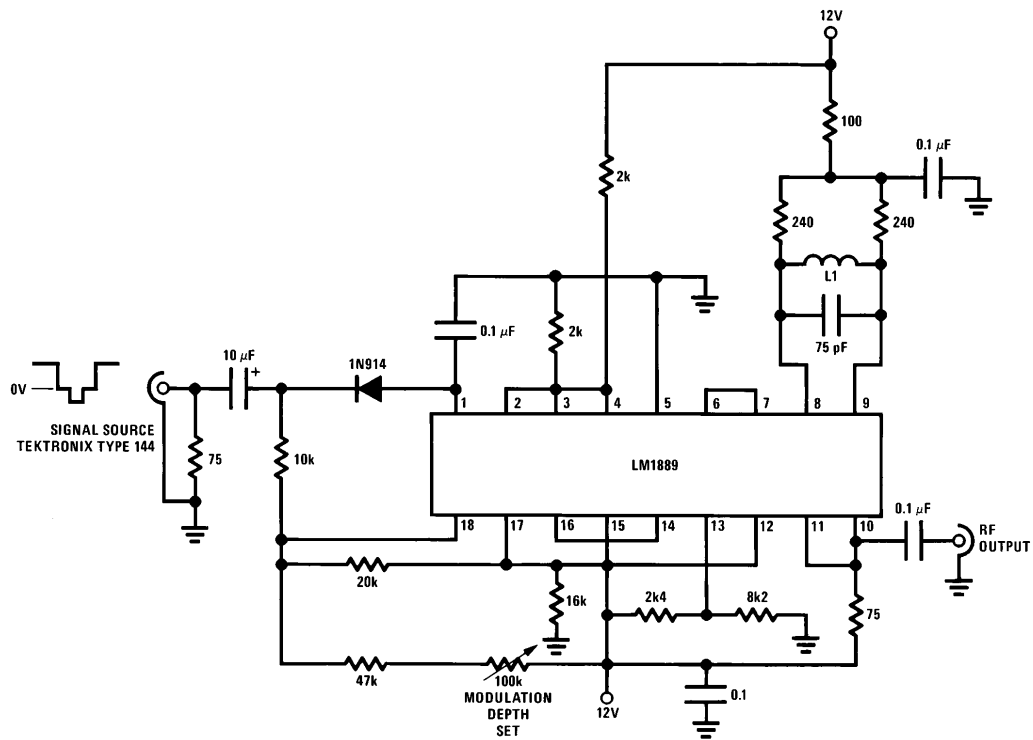
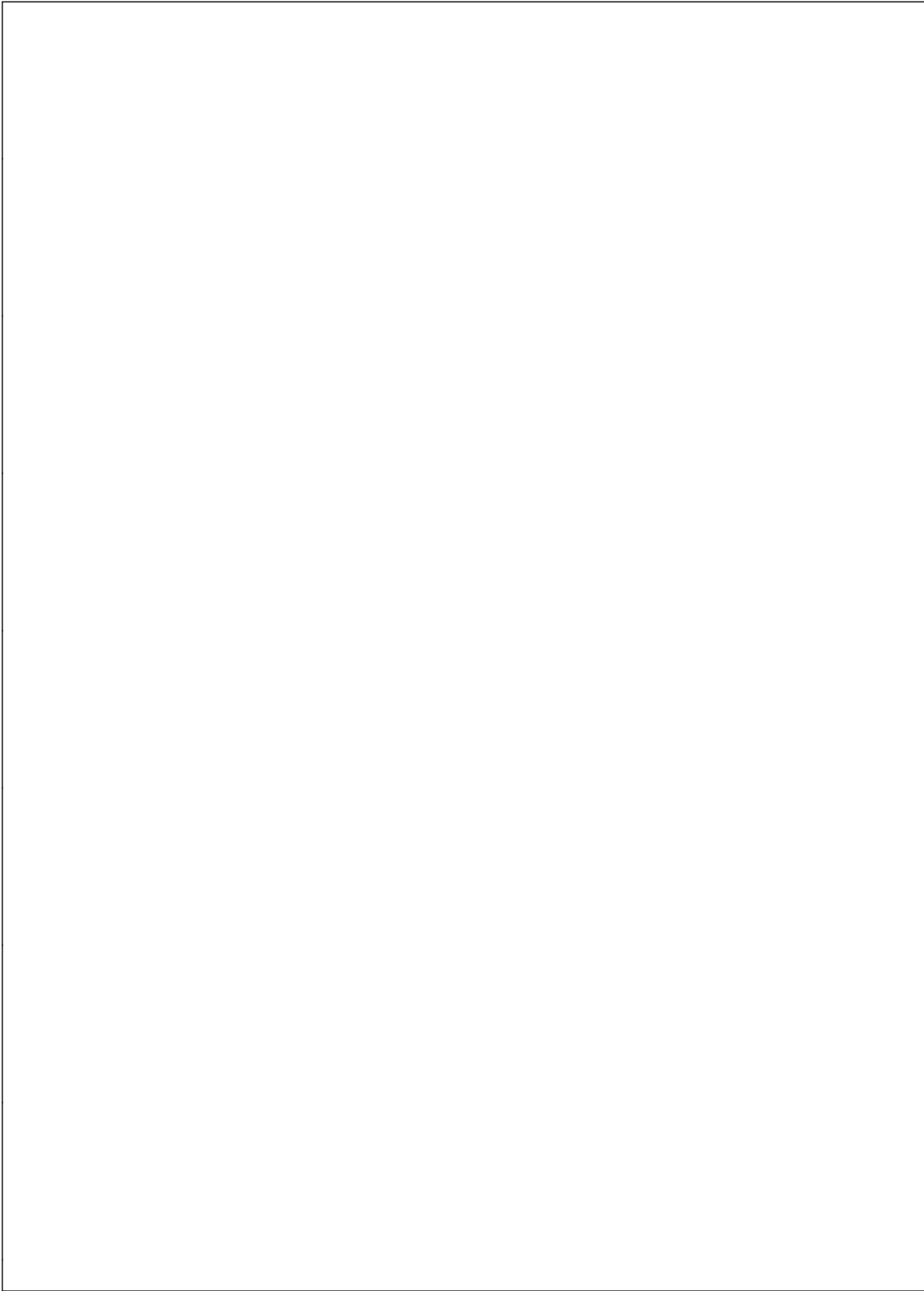
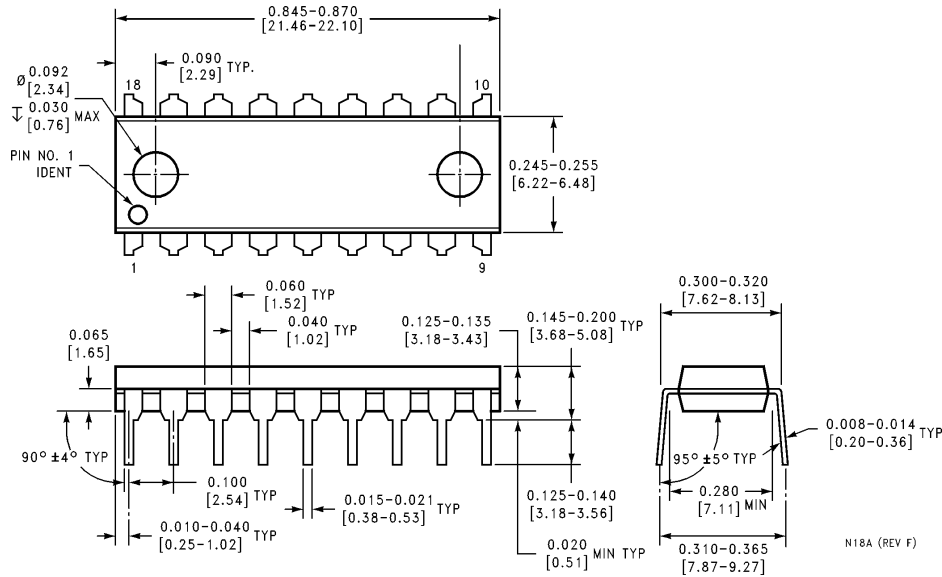

FIGURE 3. DC Clamped Modulator for NTSC Pattern Generators

TL/H/7917-9



Physical Dimensions inches (millimeters)



Molded Dual-In-Line Package (N)
Order Number LM1889N
See NS Package Number N18A

LIFE SUPPORT POLICY

NATIONAL'S PRODUCTS ARE NOT AUTHORIZED FOR USE AS CRITICAL COMPONENTS IN LIFE SUPPORT DEVICES OR SYSTEMS WITHOUT THE EXPRESS WRITTEN APPROVAL OF THE PRESIDENT OF NATIONAL SEMICONDUCTOR CORPORATION. As used herein:

1. Life support devices or systems are devices or systems which, (a) are intended for surgical implant into the body, or (b) support or sustain life, and whose failure to perform, when properly used in accordance with instructions for use provided in the labeling, can be reasonably expected to result in a significant injury to the user.
2. A critical component is any component of a life support device or system whose failure to perform can be reasonably expected to cause the failure of the life support device or system, or to affect its safety or effectiveness.



National Semiconductor Corporation
 1111 West Bardin Road
 Arlington, TX 76017
 Tel: (800) 272-9959
 Fax: (800) 737-7018

National Semiconductor Europe
 Fax: (+49) 0-180-530 85 86
 Email: cnjwge@tevm2.nsc.com
 Deutsch Tel: (+49) 0-180-530 85 85
 English Tel: (+49) 0-180-532 78 32
 Français Tel: (+49) 0-180-532 93 58
 Italiano Tel: (+49) 0-180-534 16 80

National Semiconductor Hong Kong Ltd.
 19th Floor, Straight Block,
 Ocean Centre, 5 Canton Rd.
 Tsimshatsui, Kowloon
 Hong Kong
 Tel: (852) 2737-1600
 Fax: (852) 2736-9960

National Semiconductor Japan Ltd.
 Tel: 81-043-299-2309
 Fax: 81-043-299-2408

National does not assume any responsibility for use of any circuitry described, no circuit patent licenses are implied and National reserves the right at any time without notice to change said circuitry and specifications.