

TRIACS

I _{T(RMS)} T _c =80°C 360° Conduction (Amps)	I _{TSM} (Amps)		I ² t for Fusing @ 8.3 ms (A ² sec)	Max I _{DRM} @ V _{RRM} (mA)	V _{DRM} /V _{RRM} Range (Volts)	V _{TM} @ T _J =25°C		R _{θJC} (°C/W)	Junction Temp. Range (°C)	Max V _{GT} (Volts)	Max V _{GD} All Modes (Volts)
	50 Hz	60 Hz				I _{TM} (Amps)	V _{TM} (Volts)				
16 T _c =82°C	155	170	121	3	200-600	25	1.6	2	-40 to 125	1.5 x	.2
25	230	250	260	1	200-600	35	1.58	2.4	-40 to 115	3.5	.2
25 T _c =90°C	230	250	260	2	200-600	35	1.58	1.4	-40 to 125	3.5	.2
25	230	250	260	1	200-600	35	1.58	1.8	-40 to 115	3.5	.2
25 T _c =75°C	230	250	260	1	200-600	35	1.58	1.95	-40 to 115	3.5	.2
25 T _c =75°C	230	250	260	1	200-600	35	1.58	1.95	-40 to 115	3.5	.2
25 T _c =71°C	230	250	260	1	200-600	35	1.58	2.1	-40 to 115	3.5	.2
25 T _c =75°C	230	250	260	1	200-600	35	1.58	1.95	-40 to 115	3.5	.2
25	230	250	260	1	200-600	35	1.58	1.8	-40 to 115	3.5	.2
25 T _c =70°C	240	265	375	5	400-600	45	2.5	2	-40 to 125	2.5 x	.2
40 T _c =81°C	275	300	375	.2	200-600	57	1.38	1.65	-40 to 115	3.5	.2
40 T _c =81°C	275	300	375	1	200-600	56	1.38	1	-40 to 115	3.5	.2
40 T _c =70°C	275	300	375	1	200-600	56	1.38	1.15	-40 to 115	3.5	.2
40 T _c =70°C	275	300	375	1	200-600	56	1.38	1.15	-40 to 115	3.5	.2
40 T _c =68°C	275	300	375	1	300-600	56	1.38	1.3	-40 to 115	3.5	.2
40 T _c =74°C	275	300	375	1	200-600	56	1.38	1	-40 to 115	3.5	.2
40 T _c =81°C	275	300	375	1	200-600	56	1.38	1.15	-40 to 115	3.5	.2
50 T _c =83°C	730	800	2600	10	200-800	70	1.5 T _J =125°C	.6	-40 to 125	2.5 x	.2
70 T _c =87°C	1000	1100	5000	15	200-1200	110	2.1 T _J =125°C	.3	-40 to 125	3 x	.2
100 T _c =84°C	1000	1100	5000	15	200-1200	140	2.35 T _J =125°C	.2	-40 to 125	3 x	.2
150 T _c =96°C	1820	2000	16,000	15	200-1200	220	1.8 T _J =125°C	.12	-40 to 125	3 x	.25
150 T _c =92°C	1820	2000	16,000	15	200-1200	220	1.65 T _J =125°C	.15	-40 to 125	3 x	.25
300 T _c =89°C	2730	3000	37,000	30	200-1200	420	1.5 T _J =125°C	.09	-40 to 125	3 x	.25
300 T _c =89°C	2730	3000	37,000	30	200-1200	420	1.5 T _J =125°C	.09	-40 to 125	3 x	.25

* = Isolated Tab
° = Tentative Specifications
x = 25°C Value

Critical Rate of Rise of Off State Voltage (Min) dv/dt (V/ μ sec)	Holding and Latching Current (Max) $T_J(\text{Min})$ to $T_J(\text{Max})$ DC Holding Current (mA)	DC Latching Current (mA)	Gate Current I _g Max (mA) @ $T_J(\text{Min})$	Gate Current I _g Max (mA) @ $T_J=25^\circ\text{C}$	PACKAGE INFORMATION		TYPE NO.
					STYLE	Outline	
—	6-10	—	—	30	Isolated Plastic With Fast-ons	—	°BCR16HM*
50	5	75-150	100-400	80	50	Isolated TO-3 Mounting Flange TO-239AB	SC160
50	5	75-150	100-400	80	50	Power Pak Non-Isolated Tab TO-220AB	SC129
50	5	75-150	100-400	150	75	Non-Isolated Stud	— SC260
50	5	75-150	100-400	150	75	Isolated Stud With Press on MT2 Terminal	— SC260-2
50	5	75-150	100-400	80	50	Isolated Stud With Solder Ring MT2 Terminal	— SC260-3
50	5	75-150	100-400	80	50	Isolated TO-3 Flange	— SC260-4
50	5	75-150	100-400	80	50	Non-Isolated TO-3 Flange	— SC260-5
50	5	75-150	100-400	80	50	Press Fit	— SC261
—	20	—	—	—	50	Isolated Plastic With Fast-Ons	— °BCR30GM*
50	5	75-150	100-400	150	80	Isolated TO-3 Mounting Flange TO-239AB	SC165
50	5	75-150	100-400	120	80	Non-Isolated Stud	— SC265
50	5	75-150	100-400	120	80	Isolated Stud With Press on MT2 Terminal	— SC265-2
50	5	75-150	100-400	120	80	Isolated Stud With Solder Ring MT2 Terminal	— SC265-3
50	5	75-150	100-400	120	80	Isolated TO-3 Flange	— SC265-4
50	5	75-150	100-400	120	80	Non-Isolated TO-3 Flange	— SC265-5
50	5	75-150	100-400	120	80	Press Fit	— SC266
50	20	—	—	—	100	M8 x 1.25 Stud	Metric °BCR50A
100	20	—	—	—	200	M12 x 1.5 Stud	Metric °BCR70B
100	20	20-65 Typical	—	—	200	Press Pak	14.5 x 43 mm °FB100D
100	50	20-65 Typical	—	—	300	Press Pak	14.5 x 43 mm °FB150D
100	50	15-55 Typical	—	—	300	M20 x 1.5 Stud	Metric °BCR150B
100	100	20-60 Typical	—	—	300	M24 x 1.5 Stud	Metric °BCR300B
100	100	—	—	—	300	Press Pak	14.5 x 50 mm °FB300D

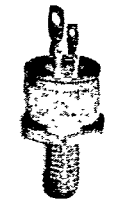

Non-isolated stud

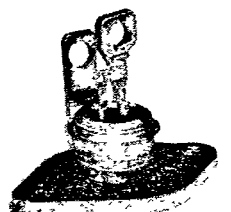
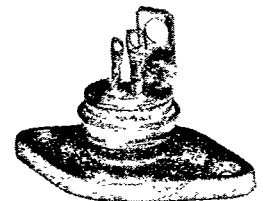

Non-isolated JEDEC TO-3 flange

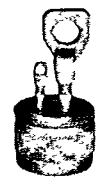

Press fit



TRIACS Outline Drawings

JEDEC TO-92

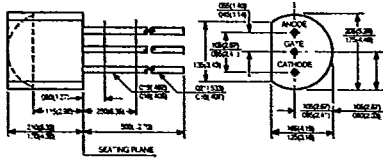

JEDEC Modified TO-92

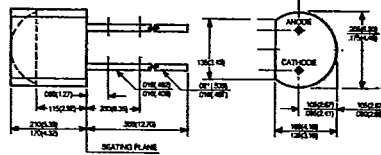

JEDEC TO-220AB

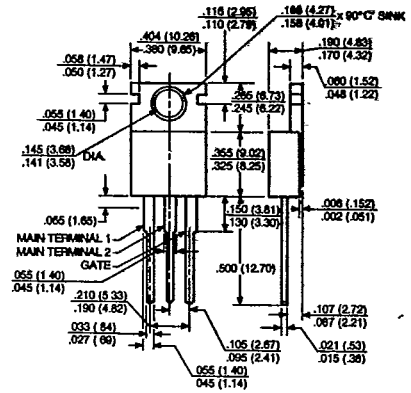

Note: TO-220 standoff distance is less.

JEDEC TO-239AB

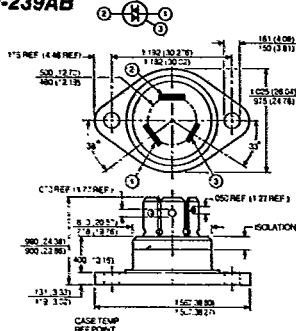

JEDEC TO-202

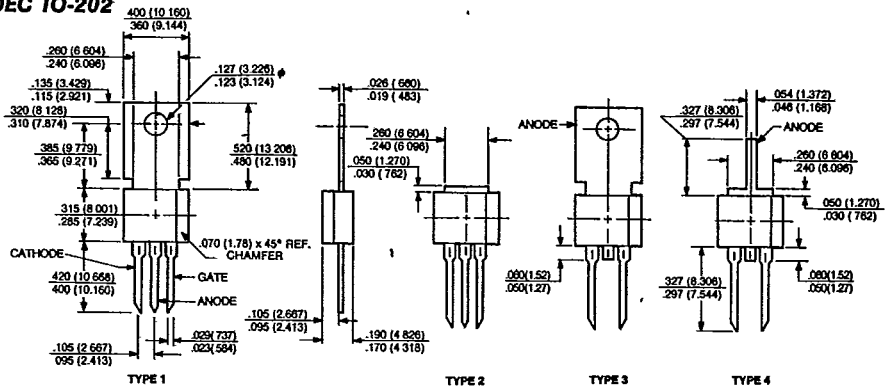

Special Triac Packages

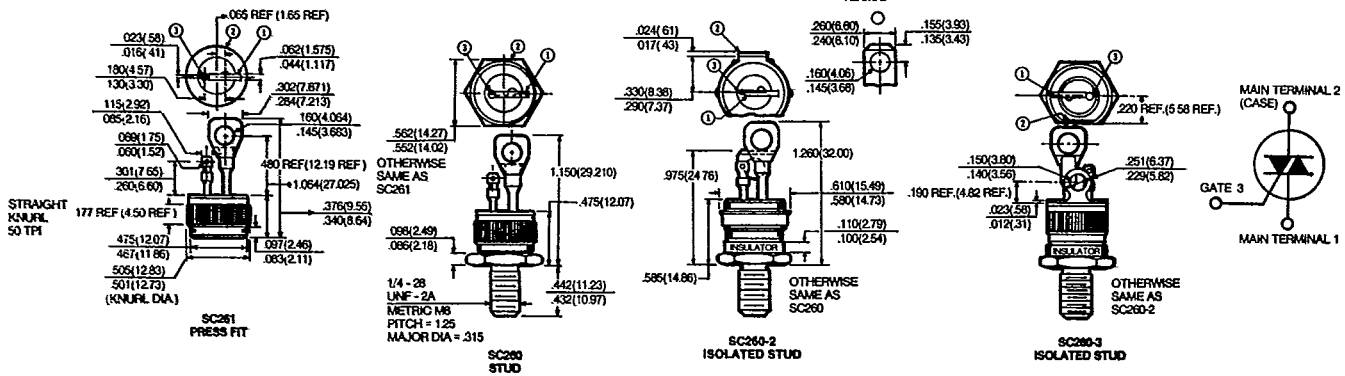

(Consult factory for flange versions.)

TRIACS

Glass Axial Leaded— Consult Factory

Isolated Plastic with Fast-Ons— Consult Factory

Metric Stud— Consult Factory

M8 x 1.25

M12 x 1.5

M20 x 1.5

M24 x 1.5

Press Pak— Consult Factory

14.5mm x 43mm

14.5mm x 50 mm

Surface Mount— Consult Factory

MP-3

SOT-89



Powerex, Inc., Hillis Street, Youngwood, Pennsylvania 15697 (412) 925-7272
 Powerex Europe, S.A., 428 Avenue G. Durand, BP107, 72003 Le Mans, France (43) 41.14.14

Taping

STANDARD SPECIFICATIONS FOR TAPING OF MOLDED PACKAGE THYRISTORS AND TRIACS

TO-92 Package

Thyristor
CR02AM, CR03AM, CR04AM
Triac
BCR1AM

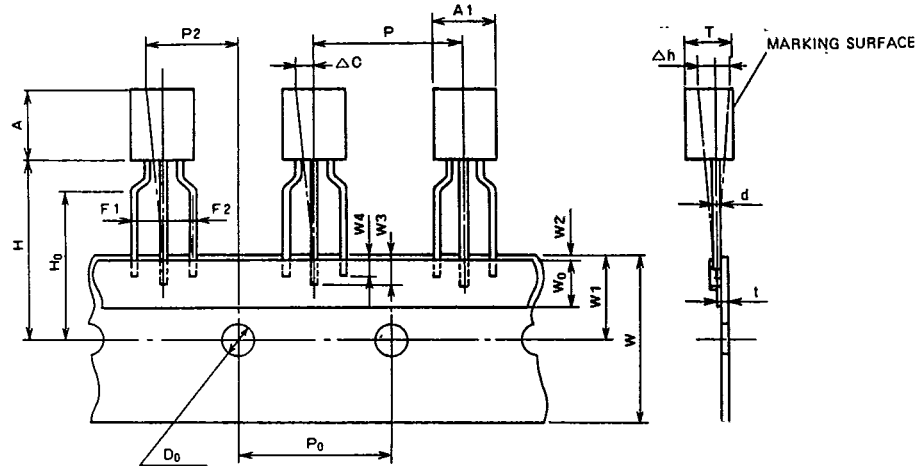

Taping dimensions

Description of symbol	Symbol	Dimensions (Unit:mm)	Remark
Product width	A1	5.0 MAX	
Product height	A	5.0 MAX	
Product thickness	T	3.7 MAX	
Lead wire diameter	d	0.6 MAX	
Sticker lead wire length (1)	W3	2.5 MIN	
Sticker lead wire length (2)	W4	2.0 MIN	
Pitch between products	P	12.7 ± 1.0	
Feed hole pitch	P ₀	12.7 ± 0.3	The cumulative pitch error is ± 1mm per 20 pitches.
Feed hole deviation (1)	P2	6.35 ± 1.3	
Distance between lead wires	F1, F2	2.5 ± 0.4	
Defective product (1)	Δh	0 ± 2.0	
Tape width	W	18.0 ± ^{1.0} / _{0.5}	
Sticker tape width	W ₀	6.0 ± 0.5	
Feed hole deviation (2)	W1	9.0 ± 0.5	
Sticker tape deviation	W2	0.5 MAX	
Position of product bottom surface	H	17.5 MIN	
Lynch height of lead wire	H ₀	16.0 ± 0.5	
Feed hole diameter	D ₀	4.0 ± 0.2	
Tape thickness	t	0.7 ± 0.2	
Defective product (2)	ΔC	0 ± 1.0	



Powerex, Inc., Hillis Street, Youngwood, Pennsylvania 15697 (412) 925-7272
 Powerex Europe, S.A., 428 Avenue G. Durand, BP107, 72003 Le Mans, France (43) 41.14.14

Powerex Semiconductor Data Book
 Taping

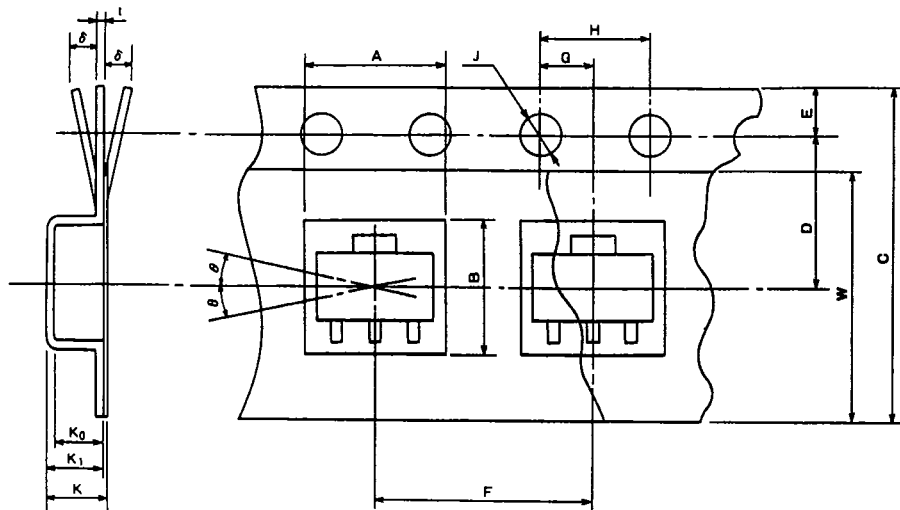

SOT-89 Package

Thyristor
 CR08AS

Taping dimensions

Description of symbol		Symbol	Dimensions/angles Unit:mm	Remark
Parts insertion	Height	A	5.0 ± 0.1	Cross-section of the surface 0.5mm above the inner bottom
	Width	B	4.6 ± 0.1	Cross-section of the surface 0.5mm above the inner bottom
Concave square hole	Depth	K ₀	1.8 ± 0.1	Inner space
	Pitch	F	8.0 ± 0.1	Cumulative error +0.1/-0.3 MAX/10 pitches
Round feed hole	Diameter	J	$\phi 1.5 \pm 0.05$	
	Pitch	H	4.0 ± 0.1	Cumulative error +0.1/-0.3 MAX/10 pitches
	Position	E	1.5 ± 0.1	Distance between the tape edge and the hole center
Distance between center lines	Vertical	G	2.0 ± 0.5	Center line of concave square hole and round feed hole
	Horizontal	D	5.65 ± 0.05	Center line of concave square hole and round feed hole
Cover tape	Width	W	$9.5 + 0.3/-0$	Thickness: 0.1 MAX
Carrier tape	Width	C	12 ± 0.2	Warp ± 0.3 MAX
	Thickness	t	0.3 ± 0.05	
	Package hole depth	K ₁	2.1 ± 0.1	
Device	Package dimensions	—	—	As shown in (e)
	Inclination	θ	30° MAX.	
Total Thickness		K	2.3 ± 0.1	Total thickness including cover and carrier tapes