

 **mitsubishi**
PROGRAMMABLE CONTROLLERS
MELSEC-F

SOFTWARE MANUAL

FX-PCS/WIN-E

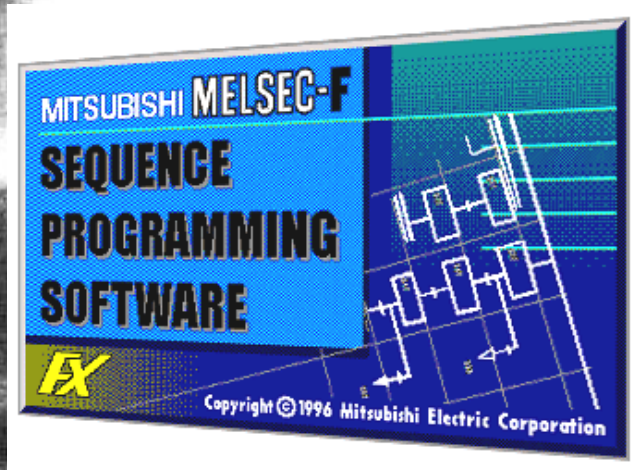

FX

FX-PCS/WIN-E

Software Manual

Manual number : JY992D66501
Manual revision : C
Date : February 1999

Foreword

- This manual contains text, diagrams and explanations which will guide the reader in the correct installation and operation of the FX-PCS/WIN-E.
- Before attempting to install or use the FX-PCS/WIN-E this manual should be read and understood.
- If in doubt at any stage of the installation of the FX-PCS-/WIN-E always consult a professional electrical engineer who is qualified and trained to the local and national standards which apply to the installation site.
- If in doubt about the operation or use of the FX-PCS/WIN-E please consult the nearest Mitsubishi Electric distributor.
- This manual is subject to change without notice.

MS,MS-DOS and Windows are registered trademarks of Microsoft Corporation.

IBM and AT are registered trademarks of International Business Machines Corporation.

All other brand and product names are trademarks or registered trademarks of their respective owners.

FAX BACK

Mitsubishi has a world wide reputation for its efforts in continually developing and pushing back the frontiers of industrial automation. What is sometimes overlooked by the user is the care and attention to detail that is taken with the documentation. However, to continue this process of improvement, the comments of the Mitsubishi users are always welcomed. This page has been designed for you, the reader, to fill in your comments and fax them back to us. We look forward to hearing from you.

Fax numbers:	Your name:
Mitsubishi Electric.....
America (708)298-1834	Your company:
Australia (02)638 7072
Germany (0 21 02)4 86-1 12	Your location:
South Africa (0111)444-8304
United Kingdom (01707)278695	

Please tick the box of your choice;

What condition did the manual arrive in? Good Minor damage Unusable

Will you be using a folder to store the manual? Yes No

What do you think to the manual presentation? Tidy Un-friendly

Are the explanations understandable? Yes Not too bad Unusable

Which explanation was most difficult to understand:

.....

Are there any diagrams which are not clear? Yes No

If so, which:

What do you think to the manual layout? Good Not too bad Un-helpful

If there one thing you would like to see improved, what is it?

.....

.....

Could you find the information you required easily using the index and/or the contents, if possible please identify your experience:

.....

.....

.....

.....

.....

.....

Do you have any comments in general about the Mitsubishi manuals?

.....

.....

.....

.....

Thank you for taking the time to fill out this questionnaire. We hope you found both the product and this manual easy to use.

Guidelines for the safety of the user and protection of the FX-PCS/WIN-E

This manual provides information for the use of the FX-PCS/WIN-E. The manual has been written to be used by trained and competent personnel. The definition of such a person or persons is as follows;

- a) Any engineer who is responsible for the planning, design and construction of automatic equipment using the product associated with this manual should be of a competent nature, trained and qualified to the local and national standards required to fulfill that role. These engineers should be fully aware of all aspects of safety with regards to automated equipment.
- b) Any commissioning or service engineer must be of a competent nature, trained and qualified to the local and national standards required to fulfill that job. These engineers should also be trained in the use and maintenance of the completed product. This includes being completely familiar with all associated documentation for the said product. All maintenance should be carried out in accordance with established safety practices.
- c) All operators of the completed equipment should be trained to use that product in a safe and co-ordinated manner in compliance to established safety practices. The operators should also be familiar with documentation which is connected with the actual operation of the completed equipment.

Note: the term 'completed equipment' refers to a third party constructed device which contains or uses the product associated with this manual.

Notes on the symbology used in this manual

At various times through out this manual certain symbols will be used to highlight points of information which are intended to ensure the users personal safety and protect the integrity of equipment. Whenever any of the following symbols are encountered its associated note must be read and understood. Each of the symbols used will now be listed with a brief description of its meaning.

Hardware warnings



Indicates that the identified danger WILL cause physical and property damage.



Indicates that the identified danger could POSSIBLY cause physical and property damage.



Indicates a point of further interest or further explanation.

Software warning



Indicates special care must be taken when using this element of software.



Indicates a special point which the user of the associate software element should be aware of.



Indicates a point of interest or further explanation.

CONTENTS

1. Introduction	1-1
1.1 Main Software Features	1-1
1.2 Contents of Product Package and System Configuration	1-3
1.3 Data File Types and Compatibility	1-5
1.4 Comment Control	1-7
2. Installing FXGP/WIN-E	2-1
2.1 Install Procedure (for Windows 3.1)	2-1
2.2 Install Procedure (for Windows 95,98)	2-2
3. Main Operation	3-1
3.1 Starting method	3-1
3.2 Operation on Initial Screen	3-2
3.3 Main screens	3-3
3.4 Ending method	3-4
4. Work Windows and their Functions	4-1
4.1 Construction and Types of Work Windows	4-1
4.1.1 Construction of work windows and relation between windows	4-1
4.1.2 Split window	4-2
4.2 Functions of Programming Window Group: View	4-3
4.3 Functions of Comment Window Group: View → Comment View	4-4
4.4 Functions of Register Window: View → Register View	4-6
4.5 Functions of Device List Window Group: View →	4-7
4.6 Functions of Sampling Trace Window Group: PLC → Sampling Trace	4-8
4.7 Functions of Device Monitor Window: Monitor/Test →	4-9
5. Menu Bar Commands and their Functions	5-1
5.1 File Menu Functions	5-2
5.1.1 New	5-2
5.1.2 Open	5-3
5.1.3 Close and Open	5-5
5.1.4 Save	5-6
5.1.5 Save As	5-7
5.1.6 Print	5-9
5.1.7 Print All	5-18
5.1.8 Page Setup	5-20
5.1.9 Print Preview	5-21
5.1.10 Printer Setup	5-23
5.1.11 Displaying file use history	5-23
5.1.12 Exit	5-24
5.2 Edit Menu Functions	5-26
5.2.1 Undo	5-27
5.2.2 Cut	5-27
5.2.3 Copy	5-27
5.2.4 Paste	5-27
5.2.5 Delete	5-27
5.2.6 Line Delete	5-28
5.2.7 Line Insert	5-29
5.2.8 Block Select	5-30

5.2.9 NOP Overwrite	5-32
5.2.10 NOP Insert	5-32
5.2.11 NOP Remove	5-33
5.2.12 Device Name	5-34
5.2.13 Device Comment	5-34
5.2.14 Coil Comment	5-36
5.2.15 Block Comment	5-36
5.2.16 Device Registration	5-38
5.2.17 Edit cancel	5-39
5.3 Tools Menu Functions	5-40
5.3.1 Contact	5-41
5.3.2 Coil	5-43
5.3.3 Function	5-45
5.3.4 Wire	5-48
5.3.5 Instruction	5-50
5.3.6 All Clear	5-51
5.3.7 Convert	5-52
5.3.8 Default comments for special M/D	5-53
5.3.9 Setting of comment moved to PLC	5-54
5.3.10 Setting of step of comment	5-56
5.4 Search Menu Functions	5-58
5.4.1 Go to Top, Go to End	5-59
5.4.2 Device Name Search	5-60
5.4.3 Device Search	5-61
5.4.4 Instruction Search	5-61
5.4.5 Contact/Coil Search	5-62
5.4.6 Go to Step	5-62
5.4.7 Go to State	5-63
5.4.8 Character Search	5-64
5.4.9 Character Exchange	5-64
5.4.10 Change Device Number	5-65
5.4.11 Change Bit Device	5-66
5.4.12 Swap Device Number	5-67
5.4.13 Tag Set	5-68
5.4.14 Tag Jump	5-68
5.5 View Menu Functions	5-70
5.5.1 Ladder View	5-71
5.5.2 Instruction View	5-72
5.5.3 SFC View	5-73
5.5.4 Inner Ladder View	5-74
5.5.5 Comment View	5-75
5.5.6 Register View	5-79
5.5.7 Tool Bar Status Bar Function Keys	5-84
5.5.8 Palette	5-85
5.5.9 Contact/Coil List	5-86
5.5.10 Device Used List	5-87
5.5.11 TC Setting List	5-88
5.5.12 Comment display	5-89
5.5.13 Display Setting	5-93
5.5.14 Zoom	5-94
5.6 PLC Menu Functions	5-95
5.6.1 Transfers	5-96
5.6.2 Register Data Transfers	5-98
5.6.3 PLC Memory Clear	5-100
5.6.4 Serial Setting (D8120)	5-101
5.6.5 PLC Keyword Current or Delete	5-102
5.6.6 Runtime Program Changes	5-105
5.6.7 Remote Run/Stop	5-109
5.6.8 PLC Diagnostics	5-110

5.6.9 Sampling Trace	5-111
5.6.10 Ports	5-116
5.7 Monitor/Test Menu Functions	5-117
5.7.1 Start monitor	5-118
5.7.2 Stop Monitor	5-120
5.7.3 Dynamic Monitor	5-121
5.7.4 Entry Device Monitor	5-122
5.7.5 Forced Y Output	5-126
5.7.6 Forced On/Off	5-127
5.7.7 Change Current Values	5-128
5.7.8 Change Setting Values	5-130
5.7.9 Display change of monitor data(□□□)	5-132
5.8 Option Menu Functions	5-134
5.8.1 Program Check	5-135
5.8.2 Parameter Settings	5-136
5.8.3 Keyword Setting	5-139
5.8.4 PLC's Mode Setting	5-140
5.8.5 Serial Setting (Parameter)	5-141
5.8.6 Printer Title	5-142
5.8.7 Device range Setting	5-143
5.8.8 Comment Move	5-144
5.8.9 PLC Type Change	5-145
5.8.10 Preferences	5-146
5.8.11 EPROM Transfer	5-147
5.8.12 Font	5-148
5.9 Window Menu Functions	5-149
5.10 Help Menu Functions	5-150
6. Creating Ladder and Instruction Programs	6-1
6.1 Use of Programming Window	6-1
6.2 Creating Ladder Programs	6-2
6.2.1 Main operations necessary for entering circuit symbols	6-2
6.2.2 Instruction type circuit entry	6-12
6.2.3 Main items necessary for programming	6-14
6.2.4 Creating circuit ladder diagram	6-17
6.3 Creating Instruction Program	6-21
6.3.1 Main operations necessary for entering instruction words	6-21
6.3.2 Creating instruction list	6-30
7. Creating SFC Programs	7-1
7.1 Description of SFC	7-1
7.1.1 Types of SFC	7-1
7.1.2 Program types	7-2
7.1.3 Structure of SFC section	7-3
7.2 Creating SFC Programs	7-4
7.2.1 Main operations necessary for entering SFC symbols	7-4
7.2.2 Cursor position and entering symbol	7-5
7.2.3 Main items necessary for creating SFC	7-6
7.2.4 Creating SFC	7-9
8. Remote Maintenance Using Telephone Line	8-1
8.1 System Configuration and Functions	8-1
8.1.1 Remote access to programmable controller	8-1
8.1.2 Sending/receiving files	8-3
8.1.3 Caution	8-4
8.2 Operation Procedures	8-5

8.2.1 Remote access to programmable controller	8-5
8.2.2 File transfer	8-7
8.3 Functions on Remote Menu	8-10
8.3.1 Connect	8-10
8.3.2 Disconnect	8-14
8.3.3 File transfer	8-15
8.3.4 Environment → Modem	8-17
8.3.5 Environment → Logging File	8-21
8.4 Data Setting on Programmable Controller Side for Remote Access	8-22
Appendix	A-1
Error Code Tables	A-1
File converter	A-5

1	Introduction
2	Installing FXGP/WIN-E
3	Main Operation
4	Work Windows and their Functions
5	Menu Bar Commands and their Functions
6	Creating Ladder and Instruction Programs
7	Creating SFC Programs
8	Remote Maintenance Using Telephone Line
	Appendix

1. Introduction

This software manual describes the outline of the of the FX-PCS/WIN-E software and the construction of the hardware system.

In addition, this manual describes how to connect various units and how to utilize the software functions, such as data file compatibility. Please read this manual before installing the software.

1.1 Main Software Features

The FX-PCS/WIN-E is the software designed for creation of sequence programs used for the Mitsubishi programmable controller FX series, and this software runs on MS-Windows 3.1 or Windows 95,98.

Programming:

- **Three types of programming windows**

For programming, three types of windows will be opened at the same time. They are the ladder diagram edit window, list edit window, and SFC edit window. You can enter or edit data while switching the active window.

- **Selection of operation type in creating ladder diagram**

To create ladder diagrams in the ladder diagram editing window, you can use the conventional keyboard operation method. With this method, you can use function keys to enter ladder symbols. In addition to this conventional operation method, you can use mouse operation method. To support mouse operation method, there are floating pallet of ladder symbols, menu commands, and function key guide.

In addition, if you use the list editing window, You can create ladder diagrams by directly entering instructions.

- **Various tools for selecting instruction from list**

This software has various tools that facilitate entry of instructions, such as contact symbols, coil instructions, and application instructions.

Particularly for application instruction entry, the list of application instructions will be displayed, and desired instructions can be selected from the list. Such interactive function will facilitate instruction entry operation.

- **Importance placed on keyboard operation**

In some work places, use of a mouse or pointing device may be difficult.

Considering such a problem, we have designed this software so that most of operation can be performed using the keyboard.

- **Entire ladder diagram edit function**

You can modify part of the diagram while looking the front and rear of the ladder block currently edited.

- **Splitting screen into two**

You can split the ladder diagram editing window, circuit monitoring window, comment editing window, etc. into two (upper and lower windows) using the split handle at the lower section of the screen. Each window can display the different sections of the document, and each screen can be scrolled individually. Use this function to display the separate sections of a document at the same time, or to monitor two sections at the same time.

Monitoring, connection through telephone line, and others:

- **Programming screen having monitoring function**

Using the ladder diagram edit window and SFC edit window, you can directly monitor the programmable controller operation.

- **Remote access to FX_{2N},FX_{2NC} programmable controller through telephone line**

Connect the FX_{2N},FX_{2NC} programmable controller to the personal computer (where this software is installed) using the modem and telephone line. You can transfer or monitor the programs through the telephone line even if the programmable controller is far away from the personal computer. This software has a telephone line connection function and remote station control function, etc.

In addition, if two personal computers where this software is installed are connected to each other through the telephone line, data files can be transferred between the computers.

- **Activation of two or more application programs**

The FX-PCS/WIN can activate two or more application programs at the same time, therefore you can display another sequence program by switching the active window, and can move or copy data between the programs using the cut and paste functions

- **Preview of printed documents**

Before printing, you can preview the images of the printed documents, such as ladder diagrams, command lists, SFC diagrams, or other printable data.

1.2 Contents of Product Package and System Configuration

1.2.1 Contents of product package

The FX-PC/WIN-E software product package contains the following items:

- 1) CD-ROM disks (1.44 MB) (system disks that can activate the SW0PC- FXGP/ WIN- E system),
1 disks
- 2) This operation manual

The cable connecting the computer system to the programmable controller and the interface unit are optional. Prepare a cable and interface unit appropriate for your system while referring to the system configuration shown on the next page.

1.2.2 Operation environment

Table:1.1

Item	Description
Operation environment	MS-windows 3.1 (386 enhanced mode), Windows 95,98*1
Computer	Computer equipped with CPU of 80486SX or above
Memory	8 MB or more (16 MB or more is recommended.)
Disk unit	Hard disk: 6 MB of free area (used for installation of the SW0PC-FXGP/WIN) CD-ROM drive
Display	Resolution:640 × 480 dots or more (800 × 600 dots or more is recommended.), 16 or more colors
Mouse	Mouse or pointing device compatible with Windows
Printer	Printer compatible with Windows
RS-232C port	With communication port setting function that enables switching of the port (COM1 through COM4)
Applicable programmable controller	Mitsubishi programmable controller FX0, FX0S, FX0N, FX, FX2C, FX2N, and FX2NC series

*1: Long file names cannot be used.

1.2.3 System configuration

The construction of the system is shown below. The cable connecting the computer system to the programmable controller and the interface unit are optional. Select an appropriate cable and interface unit while referring to the following description.

Components and their connection

Use the insulation type interface unit of portable type 1) or incorporated type 2) for data conversion between the RS-232C and the RS-422. Use the specified cable 8) to connect the computer to the interface unit. Considering the type of the programmable controller, select an appropriate cable from the three 5) through 7) to connect the interface unit to the programmable controller.

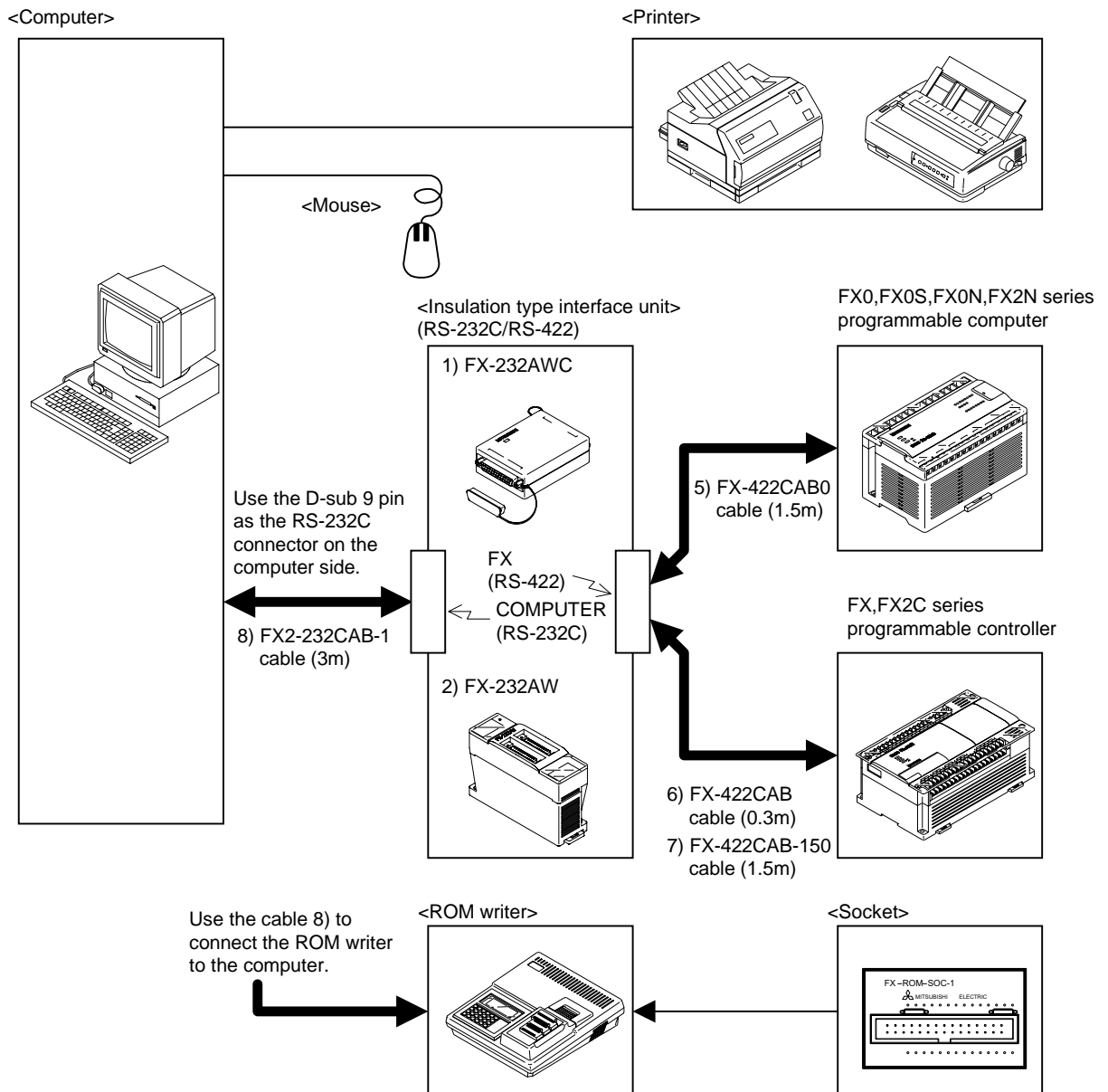

1.3 Data File Types and Compatibility

Data files on Windows

The sequence programs and comments created by the FXGP/WIN-E will be stored using the following file names:

Table:1.2

File name	Extension	Data stored in file
Program file *1	PMW	Parameter, program, file register, and comment
Comment file *2	COW	Device comment, block comment, coil comment, and device name
Register file *1	DMW	Data register and RAM file register
Sampling trace file	STW	Result of sampling trace
Printer title file	PTW	Printing style
Entry device monitor file	RMW	Content of Entry device monitor setting

For these data files, the special format for the FXGP/WIN-E is used. The SW1PC-FX/EE (AT compatible machine, DOS version) and the A6GPP/PHP, therefore, cannot read these files.

*1: Only the program file and register file data will be stored in the memory of the programmable controller and the optional memory cassette. Other files will be stored in the peripherals.

*2: The comments stored in the comment file are controlled by the peripherals.
To control the comments to be written in the program memory of the programmable controller, refer to Sec. 1.4 "Comment Control".

Storing data in DOS file

To store data in a DOS file, select File and then Save As. Program files (.PMC) and comment files (.COK) are saved. Up to sixteen characters are allowed as a file name, and excessive characters are deleted.

Applicable DOS application program:

- SW1PC-FXGP/ EE (designed for AT compatible machine)

Reading various data files

The FXGP/WIN-E has data file conversion function that converts the data files created by peripheral units into the Windows type.

Applicable software models:

- SW1PC-FXGP/EE (for AT compatible machine, DOS version)

Files to be converted:

- Program file (PMC)
- Data register file (DMD, DME, DMG)
- RAM file register (DMF)
- Comment file (COK)
- Sampling trace file (STA)
- Printer title file (PTL)

Files not to be converted:

- Comment file (COH)
- Block comment file (COL)
- Diversion circuit file (DAT)

Sequentially select File Open Save As Type and DOS Files (*.pmc) to open a file. When opened, the file will be automatically converted. The converted data can be stored as the FXGP/WIN-E file described on the previous page.

1.4 Comment Control

The FXGP/WIN-E V2.00 or above has enabled storage of the device comments in the parameter-set comment area of the sequence program memory in the programmable controller.

Comment control using FXGP/WIN-E:

If the FXGP/WIN-E is used, the peripherals can control both types of comments as the device comments; comments to be controlled by peripherals and comments to be written in the programmable controller.

These device comments can be entered using the input device comment window or comment list edit window (see Sec. 5.2.13 and Sec. 5.5.5).

Setting comments to be written in programmable controller:

The device comments to be controlled by the peripherals can be written in the parameter-set comment area of the program memory in the programmable controller.

The device comments can be written in the comment area until the comment area is fully loaded (the comment storage capacity is parameter set). The minimum unit for device comment storage is one comment.

- Parameter setting (see Sec. 5.8.2)
- Device comment entry and specifications (see Sec. 5.2.13)
- Setting of comments to be written in programmable controller (see Sec. 5.3.9)
- Editing and displaying of device comments using device comment/name window (see Sec. 5.5.5)

Controlling sequence program including comments:

Programmable controller

- Reading out from programmable controller:
The comments read out from the programmable controller will be transferred to the device comment area of the FXGP/WIN-E. After transfer, the comments will be set as the comments to be written in the programmable controller, and the corresponding device numbers shown in the list window will have an asterisk *.
- Writing into programmable controller:
The device comments to be written in the programmable controller (comments marked with as asterisk *) will be written in the comment area of the program memory in the programmable controller.

File

- Reading out from sequence program file:
Before opening a file, a confirmation message will appear and ask you whether the comments in the program memory should be transferred to the device comment area of the FXGP/WIN-E. Click Yes to transfer the comments to the device comment area of the FXGP/WIN-E. If you click No, the comments will be loaded in the FXGP/WIN-E as the program data, therefore the device comment area of the FXGP/WIN-E will not be subject to change. Even if comments are once loaded in the FXGP/WIN-E, you can transfer the comments into the device comment area later (see Sec. 6.8.8). After clicking Yes, the comments are transferred into the device comment area, and regarded as the comments to be written in the programmable controller. In addition, the corresponding device numbers displayed in the list window will be marked with an asterisk *.
- Writing in sequence program file:
The device comments to be written in the programmable controller (comments marked with an asterisk *) will be written in the program memory, and then stored in the file. All the device comments are stored in the comment file (.COW).
- Importing into comment file:
No comment data will be imported into the device comments if the comments are specified as the comments to be written in the programmable controller (if the comments are marked with as asterisk * in the device comment/name window).
- Exporting from comment file:
All the device comments in the FXGP/WIN-E will be stored in the file.

ROM writer

Data will be read out and written in the ROM writer in the same way as the programmable controller.

1	Introduction
2	Installing FXGP/WIN-E
3	Main Operation
4	Work Windows and their Functions
5	Menu Bar Commands and their Functions
6	Creating Ladder and Instruction Programs
7	Creating SFC Programs
8	Remote Maintenance Using Telephone Line
	Appendix

2. Installing FXGP/WIN-E

This section describes the FXGP-WIN-E install procedure.

Before installing the FXGP/WIN-E, be sure to install the necessary system software, such as MS-DOS and MS-Windows.

2.1 Install Procedure (for Windows 3.1)

- 1) Turn on the power of the computer, and start Windows.
- 2) Insert the SW0PC- FXGP/WIN system CD into the CD-ROM drive.
- 3) Click Icon in the Program Manager dialog box.
- 4) Click Run.
- 5) Click in the Command Line box, and type "X: SETUP EXE". (X= CD-ROM drive name)
- 6) Click the OK button.
- 7) Specify the directory where the FXGP/WIN-E should be installed. The default is C:\FXGPWIN
- 8) Follow the directions shown on the screen to install the FXGP/WIN-E.



Application program delete:

- To delete this software (application program) from the hard disk, be sure to delete all the files from the install directory, and the FXGPWIN. INI files from the Windows directory using the file manager, etc. If program files are stored in the directory, be sure to back up the files before deleting this application program. If the program files are not deleted, it will be deleted together with the application program.

Initialize of FXGP/WIN-E:

- 1) FXGP/WIN-E is ended.
- 2) Delete the FXGP/WIN.INI files from the Windows directory.
- 3) Restarted the FXGP/WIN-E.

2.2 Install Procedure (for Windows 95,98)

- 1) Turn on the power of the computer, and start Windows.
- 2) Insert the SW0PC- FXGP/WIN system CD-ROM into the CD-ROM drive.
- 3) Click the Start button, and then click Run.
- 4) Click in the Name box, and type "X: SETUP32.EXE". (X = CD-ROM drive name)
- 5) Click the OK button.
- 6) Specify the directory where the FXGP/WIN-E should be installed. The default is C:\FXGPWIN
- 7) Follow the directions shown on the screen to install the FXGP/WIN-E.



Application program delete:

After installation on Windows 95 or 98, you can delete the software once installed from the hard disk whenever necessary. To delete the FXGP/WIN-E software once installed, double-click the My Computer icon on the Desktop, and then sequentially click Control Panel and Add/Remove Programs.

Initialize of FXGP/WIN-E:

- 1) FXGP/WIN-E is ended.
- 2) Delete the FXGP/WIN.INI files from the Windows directory.
- 3) Restarted the FXGP/WIN-E.

1	Introduction
2	Installing FXGP/WIN-E
3	Main Operation
4	Work Windows and their Functions
5	Menu Bar Commands and their Functions
6	Creating Ladder and Instruction Programs
7	Creating SFC Programs
8	Remote Maintenance Using Telephone Line
	Appendix

3. Main Operation

This section describes main operation of the FXGP/WIN-E.

Note that operation methods described in this section are not the special methods used for the FXGPWIN-E only, but are the common operation methods used in the Windows environment.

For an inexperienced operator of Windows, it is recommended that the MS-Windows operation manual should be used in conjunction with this manual.

3.1 Starting method

At the completion of install, the MELSEC-F FX application group will be created, and the FXGP/WIN-E start icon will be stored.

The figure below shows the Windows 3.1 screen.

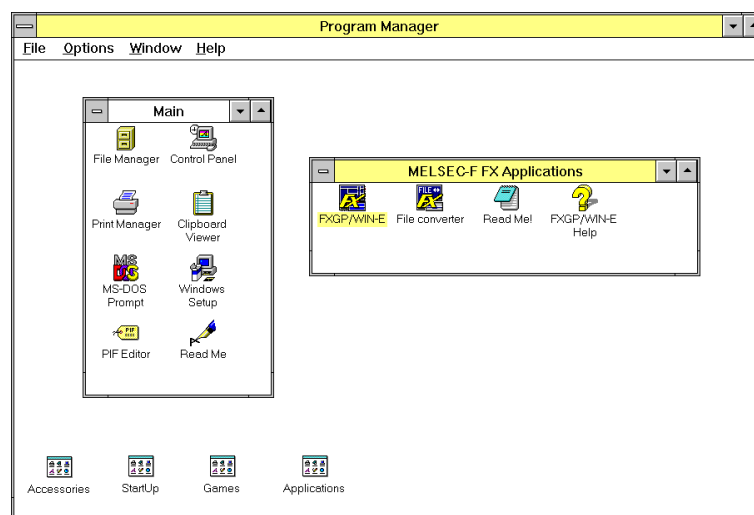

Double-click on this icon to start the FXGP/WIN-E.

The FXGP/WIN-E can activate two or more programs at the same time. For this reason, after starting the FXGP-WIN-E, if the icon is double-clicked again, another FXGP/WIN-E will be started.

3.2 Operation on Initial Screen

File-New

Use this function to create a new sequence program.
Select the programmable controller type, and then click the OK button.
A new file will appear on the display, and you can enter data.

File-Open

Use this function to read out a program file from the floppy disk or hard disk.

- Select a file type from the Save As Type box, and then select a drive, directory, and file name.
- From the Save As Type box, you can select FXGP/WIN-E type program files (*.pmw) or DOS type program files (*.pmc).

PLC-Transfers

Use this function to read out the programs from the programmable controller connected to the computer.
Before reading out the programs, be sure to connect the computer to the programmable controller using cables and interface unit.

PLC-Ports

Use this function to select an RS- 232 port of the personal computer in order to connect the programmable controller or ROM to the computer.

Remote- See.Sec.8.3 "Functions on Remote Menu"

3.3 Main screens

This section describes the main screens of the FXGP/WIN-E.

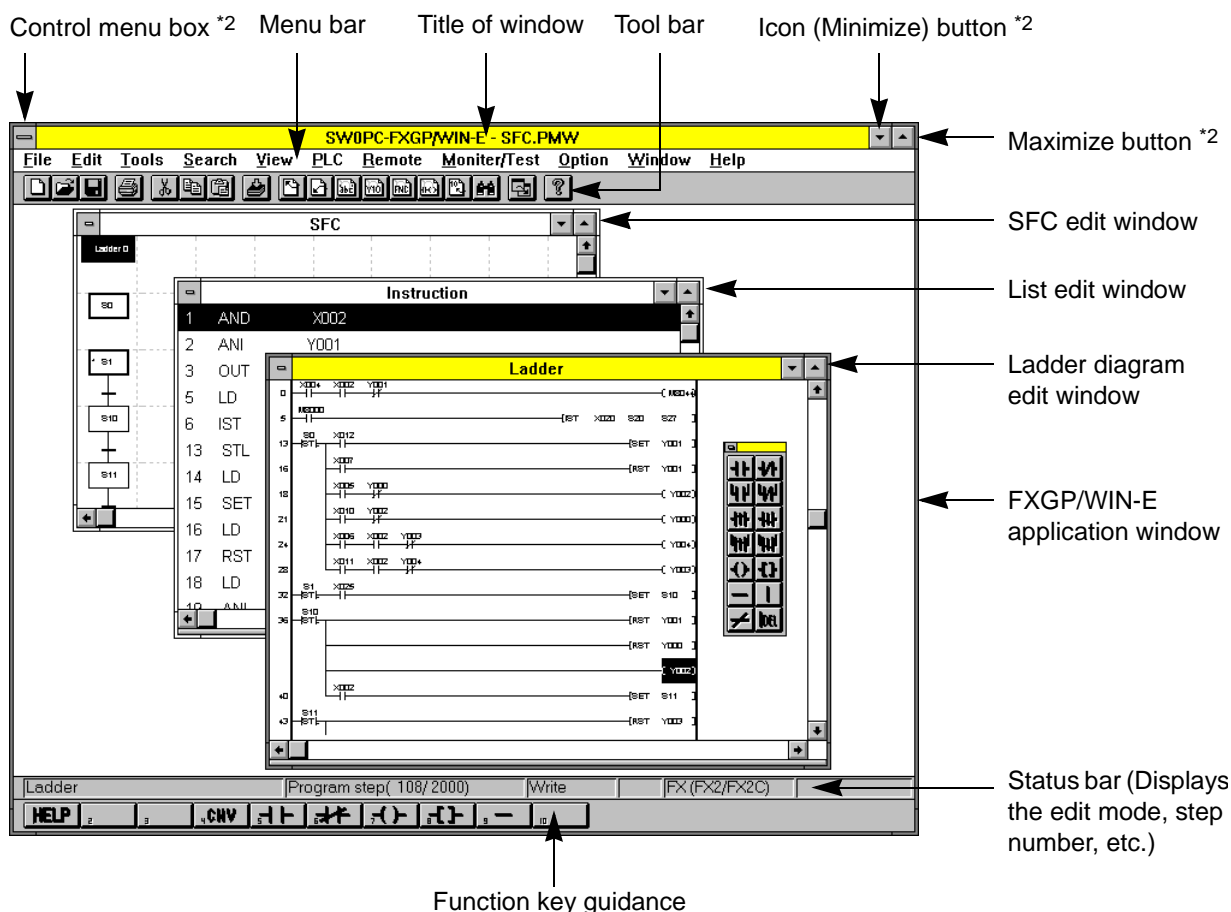

The Icon (Minimize) button can minimize the size of the ladder diagram edit window, list edit window, etc. in the FXGP/WIN-E application window. The minimized windows look like icons.

*2: When Windows 95,98 is used, the FX icon will be displayed in place of the control menu box. In addition, the Icon (Minimize), Maximum, and Close buttons are different from those shown above.

3.4 Ending method

There are two ending methods for the FXGP/WIN-E.

For either method, if there is a non- stored file, the following confirmation dialog box will appear on the display:

- 1) Sequentially select File and then Exit.
- 2) Click in the control menu box of the application window, and then select Close.
When Windows 95,98 is used, click on the FX icon at the upper left corner of the box, or the Close button (×) at the upper right corner of the box.



The FXGP/WIN-E can open two or more the application windows.

Note that the Exit command is valid only for the application window currently active. If two or more sequence programs are activated, sequentially end the programs by sequentially activating the application windows.

1	Introduction
2	Installing FXGP/WIN-E
3	Main Operation
4	Work Windows and their Functions
5	Menu Bar Commands and their Functions
6	Creating Ladder and Instruction Programs
7	Creating SFC Programs
8	Remote Maintenance Using Telephone Line
	Appendix

4. Work Windows and their Functions

The FXGP/WIN-E has six work windows that ensure efficient programming. Various types of operation can be performed using these windows.

To create a program, open a window appropriate for the work, and then create the program. Monitoring is also possible. Various function that can be executed in each window will be shown in the menu bar. The menu bar, therefore, is optimized for each work window.

4.1 Construction and Types of Work Windows

4.1.1 Construction of work windows and relation between windows

The work windows of the FXGP/WIN-E can be divided into six types as shown below.

Each window group can display two or more windows at the same time, and the active window can be switched in each window group to proceed to the next work. You can minimize the unused window to keep it on the screen until you use it. The minimized window looks like an icon.

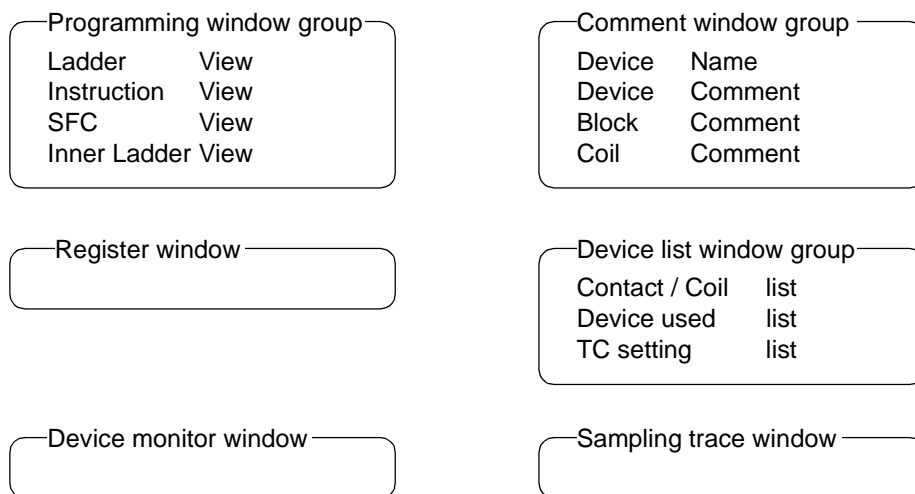

4.1.2 Split window

The ladder diagram edit window, list edit window, comment window and register window can be split. Split the window into two; upper and lower windows. These windows can display respective sections.

Example of ladder diagram edit window (in monitoring mode)

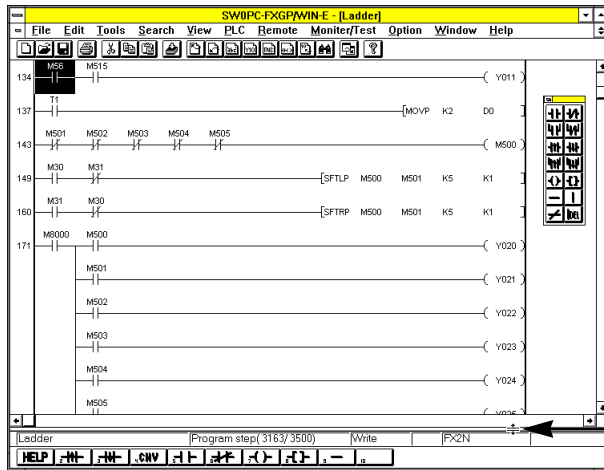

Move the split handle using the mouse to the split position. Adjust the split position to adjust the upper and lower areas.

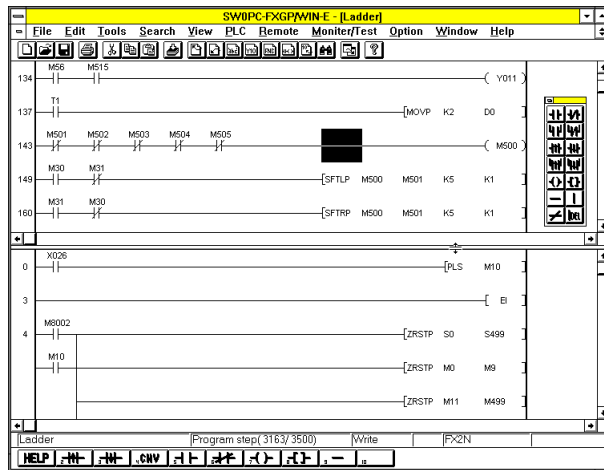

Use the scroll bar of each window to select the section to be displayed.



After you edit a ladder diagram in a split window, be sure to store the changed data, and then move to another window.

4.2 Functions of Programming Window Group: View

Use the programming windows to display or edit sequence programs.

When a ladder diagram or SFC diagram is displayed, you can monitor the operation of the programmable controller.

Ladder View

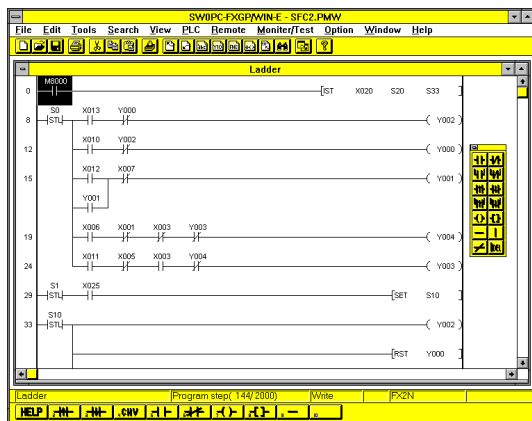

Main functions:

- Displays sequence circuits.
- Creates or edits sequence circuits.
- Monitors operation of programmable controller.
- Displays or stores comments.
- Writes data in run mode.
- Prints ladder diagrams.

Instruction View

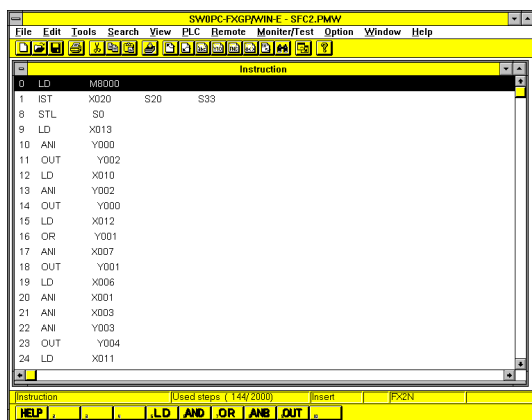

Main functions:

- Displays the sequence instruction list.
- Creates or edits the sequence instruction list.
- Displays or stores comments.
- Prints the instruction list.

SFC View

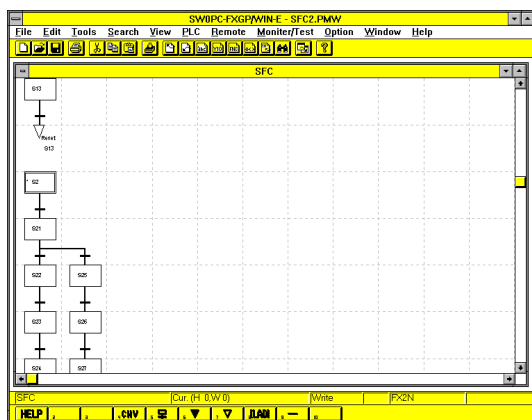

Main functions:

- Displays sequence circuits using the SFC format.
- Creates or edits SFC diagrams.
- Monitors operation of the programmable controller using the SFC diagram.
- Displays or stores comments.
- Prints SFC diagrams Execute View (V) and then Inner Ladder View (A) in the SFC edit window to display the inner state or transition circuit.

4.3 Functions of Comment Window Group: View →Comment View

Use the comment windows to display, store, or edit the device names and device comments.

Device comment / Device name

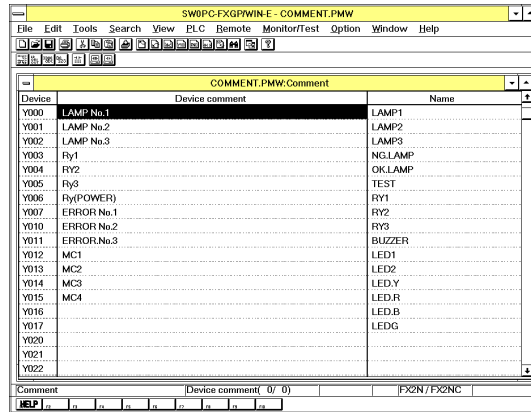

Main functions:

Device name

- Stores and edits device names.
- Displays all the device names stored.
- Prints device names.

A device name can be stored for each programmable controller device number.

Device names, therefore, can be used in place of the device numbers in creating a program or displaying a program.

Device comment

- Stores or edits device comments.
- Displays all the device comments stored.
- Prints device comments.

Device comments are added to the programmable controller device numbers.

When a program is displayed, devices will be displayed. To these devices, device comments can be added.

Block comment

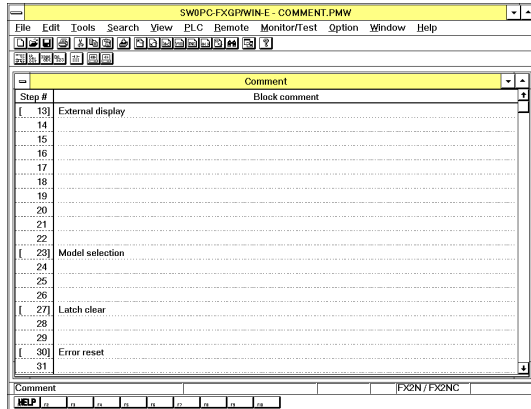

Main functions:

- Stores and edits device names.
- Displays all the device names stored.
- Prints device names.

A device name can be stored for each programmable controller device number.

Device names, therefore, can be used in place of the device numbers in creating a program or displaying a program.

Coil comment

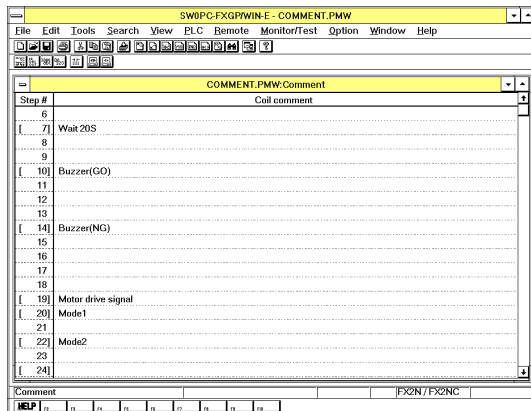

Main functions:

- Stores or edits device comments.
- Displays all the device comments stored.
- Prints device comments.

Device comments are added to the programmable controller device numbers.

When a program is displayed, devices will be displayed. To these devices, device comments can be added.

4.4 Functions of Register Window: View → Register View

Use the register window to display the data register or file register read out from the programmable controller. Also use the register window to edit the data of the data register or file register. At the completion of data editing, the FXGP/WIN-E can write the edited data in the programmable controller.

Examples of displayed windows

16-bit table type

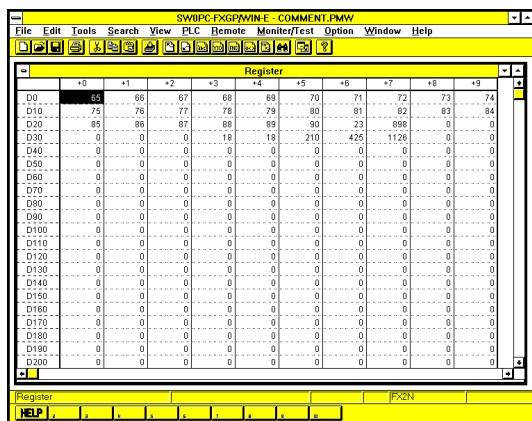

Main functions:

- Displays or edits the data of the data register or file register read out from the programmable controller.
- Creates or edits data of the data register or file register, and writes the created or edited data in the programmable controller.
- Prints register data.

32-bit line type

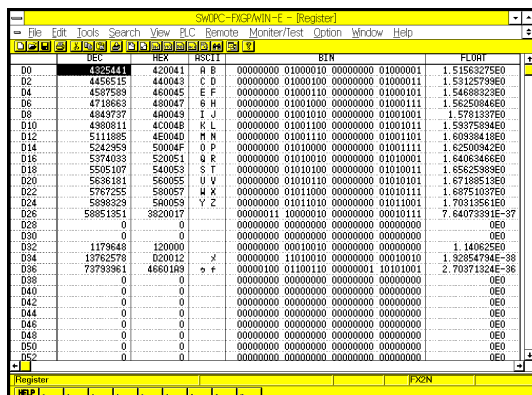

There are two or more optional register display methods. If a different display method is specified, the displayed screen may differ from the example shown in the left figure.

4.5 Functions of Device List Window Group: View →

Use the device list windows to search the devices (X, Y, M, S, T, C, D, P, I, N, V, Z, etc.) incorporated in the programmable controller and to display how the devices are used in sequence programs.

Contact/Coil list

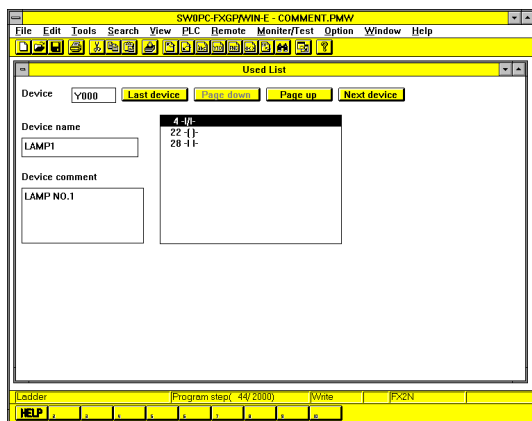

Main functions:

- Displays step numbers to clarify where the contacts and the output coils of the specified device are used in the program.
- Displays device names and device comments.
- Searches the program for the specified contact or output symbol.
- Click the contact or symbol to specify it.)
- Prints the list.

Device used list

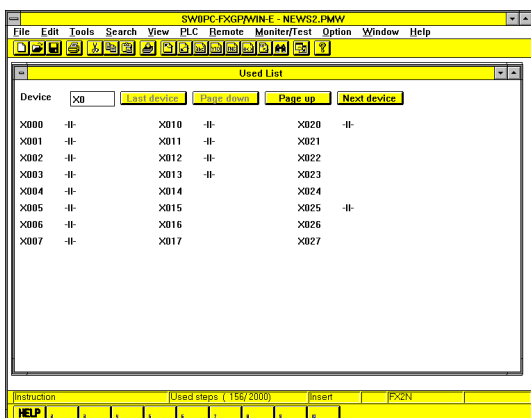

Main functions:

- Displays whether the specified contacts and output coils are used in the program. (Specify a device, and the use conditions of 24 contacts and coils started from the specified device will be displayed.)
- Prints the list.

TC setting list

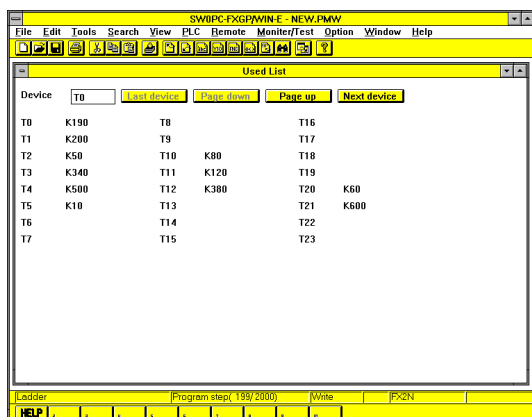

Main functions:

- Displays the timer or counter setting values written in the program. (Specify a device, and the setting values of 24 timers and counters started from the specified device will be displayed.)
- Prints the list.

4.6 Functions of Sampling Trace Window Group: PLC → Sampling Trace

Use the sampling trace windows to display the device on/ off operation and data change detected by the sampling trace function. A time chart will be used as the display format.

Example of displayed window

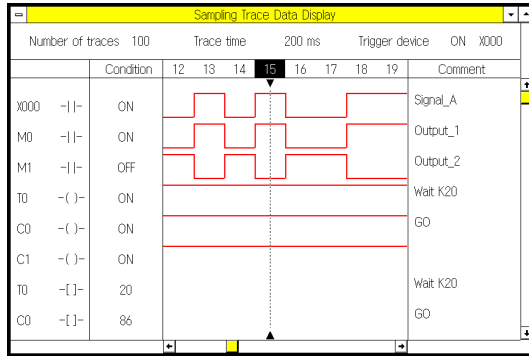

Main functions:

- Displays the operation history of the specified device.
The on/ off operation of the bit devices and the numeric values of the word devices will be displayed.
- Displays the detailed operation of the bar position. (Move the bar to display the detailed operation of another position.)
- Prints the sampling trace result.

4.7 Functions of Device Monitor Window: Monitor/Test →

Use the device monitor window to monitor the operation of the programmable controller devices on the screen.

Entry device monitor

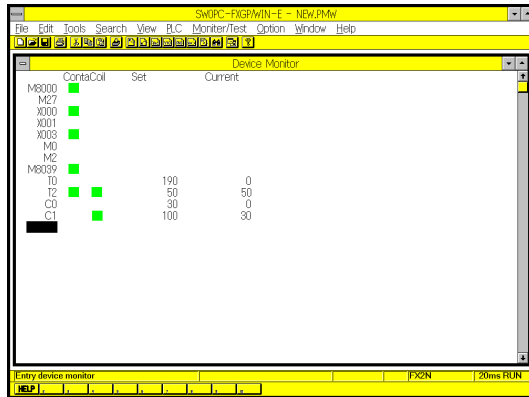

Main functions:

- Monitors operation of the input relay (X), output relay (Y), auxiliary relay (M), state (S), timer (T), counter (C), data register (D), and index registers (V and Z).
- Up to 48 device numbers can be stored.
- The data register display type can be selected from the following types: 16/32 bit, binary, decimal, hexadecimal, ASCII, and floating point display types.

MEMO

1	Introduction
2	Installing FXGP/WIN-E
3	Main Operation
4	Work Windows and their Functions
5	Menu Bar Commands and their Functions
6	Creating Ladder and Instruction Programs
7	Creating SFC Programs
8	Remote Maintenance Using Telephone Line
	Appendix

5. Menu Bar Commands and their Functions

This section describes the functions of the commands shown on the pull-down menus of the menu bar. The commands shown on a pull-down menu depend on the edit window currently active and operation status. In addition, the function of the same command may be changed when the active window is switched.

Description of this section

This section describes all the commands of each pull-down menu. The command-valid windows and operation status will be shown first for each command.

Showing valid commands:

OPN	L/V	L/M	I/V	S/V	S/M
	✓		✓	✓	
—	C/V	R/V	D/L	D/M	SMP
	✓	✓	✓	✓	✓

← Window or operation status
 ← Check mark showing valid command

- OPN : Opening
- L/ V : Ladder View
- L/ M : Ladder Monitor
- I/ V : Instruction View
- S/ V : SFC View
- S/ M : SFC Monitor
- C/ V : Comment View
- R/ V : Register View
- D/ L : Contact/Coil list, Device used list, TC setting list
- D/ M : Device Monitor
- SMP : Sampling trace

5.1 File Menu Functions

The File menu has various functions, such as new program file create, read, save, print, and FXGP/WIN-E end functions.

5.1.1 New

OPN	L/V	L/M	I/V	S/V	S/M
✓	✓	✓	✓	✓	✓
—	C/V	R/V	D/L	D/M	SMP
	✓	✓	✓	✓	✓

Use this command to create new sequence program files.

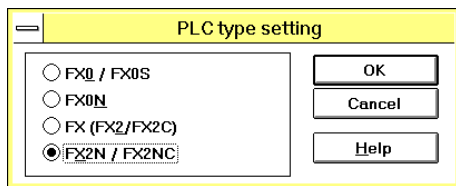

- Execute File and then New. The PLC Type Setting dialog box will appear on the display.
- Select a programmable controller type, and then click the OK button.



- Commands, internal devices, and number of steps usable for programming depend on the programmable controller type specified in the PLC Type Setting dialog box.

5.1.2 Open

OPN	L/V	L/M	I/V	S/V	S/M
✓	✓	✓	✓	✓	✓
—	C/V	R/V	D/L	D/M	SMP
	✓	✓	✓	✓	✓

Use this command to read out a program file from the floppy disk or hard disk.

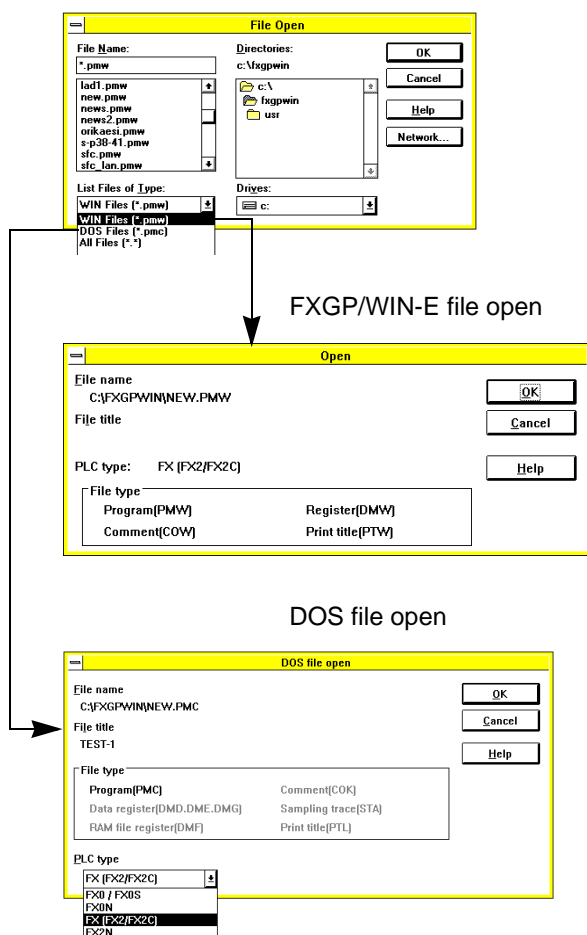

- Execute File and then Open. The Open dialog box will appear on the display.
- From the File Type box, you can select the FXGP/WIN-E program files (*.pmw) or DOS files (*.pmc).

- Check the items set in the window, and then click the OK button.
- Any file types shown in the File Type box can be read out. The dimmed file types, however, cannot be read out because they do not exist.

- The data in the DOS file will be converted into the FXGP/WIN-E data, and then read out.
- Any file types shown in the File Type box can be converted. The dimmed file types, however, cannot be converted because they do not exist.
- Check the items set in the window. After that, select the programmable controller type from the PLC Type box, and then click the OK button.

To open a file including comments:

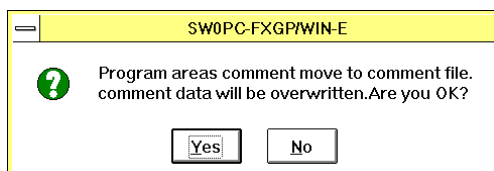

- When a sequence program is opened, if the sequence program includes comments stored in the program memory, the message shown in the left figure will appear. In the message window, click Yes to transfer the comments to the FXGP/WIN-E device comment area. In addition, the comments transferred will be set as the device comments to be written in the programmable controller. (See Sec. 1.4 and Sec. 5.3.9.) If you click No in the message window, the comments will be loaded in FXGP/WIN-E as the program data, therefore the device comment area will not be subject to change. However, after loading the comments as the program data, you may want to convert them into the device comments. In this case, convert the comments into device comments while referring to Sec. 5.8.8.

Files to be read at the same time

- Open a program file (*.PMW type file) by executing the Open and Close and Open commands. All the related files will be read out.
- Files to be read out:

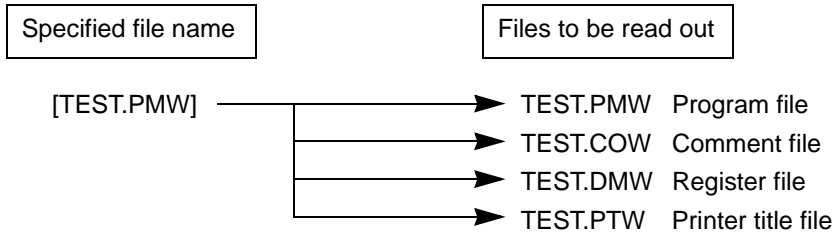

As described above, if you specify TEST. PMW and then execute Open, four files shown above will be read out at the same time. For this reason, always specify the *.PMW type file even if you want to open a file other than the program file, such as a comment file or register file.

If the *.COW, *.DMW, or *.PTW file is deleted for some reasons, only the existing files will be read out. Note that if the *.PMW type file is deleted, no files will be read out even if some files are stored.

To read out the sampling trace file (*.STW), sequentially execute PLC, Sampling Trace, and then Read from Result File.

5.1.3 Close and Open

OPN	L/V	L/M	I/V	S/V	S/M
	✓		✓	✓	
—	C/V	R/V	D/L	D/M	SMP
	✓	✓	✓	✓	✓

Use this command to close the current program file and open another existing file.

1) If the program is not changed

- Execute File and then Close and Open. The current file will be immediately closed.
- After closing the file, the File Open dialog box will appear on the display (see Sec.5.1.2).

2) If the program is changed

Execute File and then Close and Open. One of the following dialog boxes will appear on the display. The dialog box will depend on whether the file name is specified.

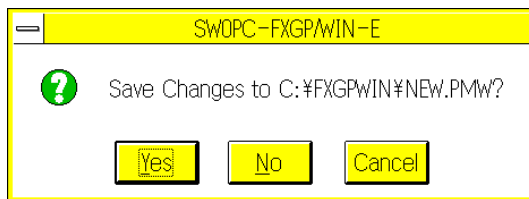

- If the file name is already specified, the message in the dialog box will ask you whether the data should be overwritten on the specified file.

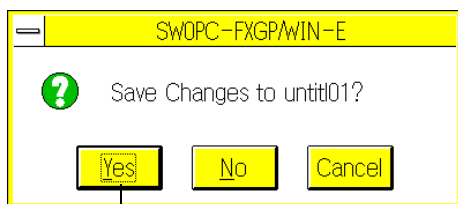

- If the data is new and has no file name, the message shown in the dialog box will ask you whether the data should be stored in the untitled file.

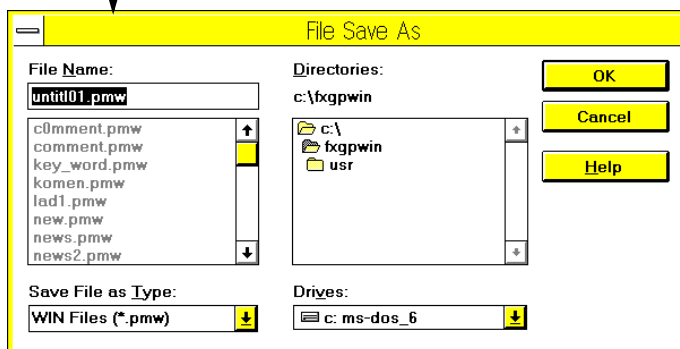

To store the program data, specify the directory and the file name and then click the OK button. If no file name is specified, the data will be stored in a temporary file, Untitl*.pmw. For a detailed description of Save As dialog box, refer to Sec.5.1.5.

5.1.4 Save

OPN	L/V	L/M	I/V	S/V	S/M
	✓		✓	✓	
—	C/V	R/V	D/L	D/M	SMP
	✓	✓	✓	✓	✓

Use this command to overwrite the currently-displayed program data in the specified file.

1) When an existing file is open

Execute File and then Save. The program data will be immediately overwritten.

At the completion of overwrite, the program will not be closed, therefore you can continuously edit the program.

2) When a new file is open

Execute File and then Save As. The Save As dialog box will appear on the display.

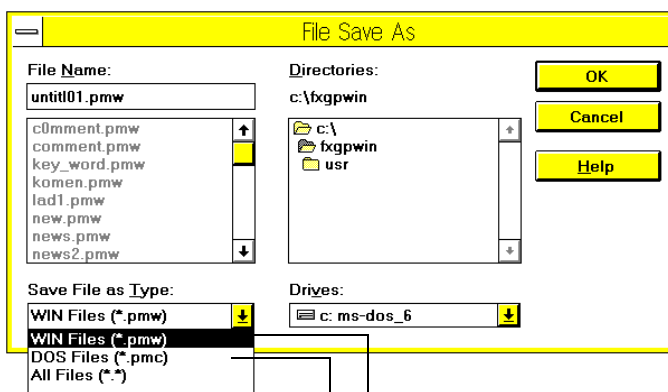

Specify the directory and the file name, and then click the OK button. If no file name is specified, the data will be stored in a temporary file, Untitled**.pmw.

Stores data in the FXGP/ WIN-E type file.

Stores the data in the DOS type file.

5.1.5 Save As

OPN	L/V	L/M	I/V	S/V	S/M
	✓		✓	✓	
—	C/V	R/V	D/L	D/M	SMP
	✓	✓	✓	✓	✓

Use this command to store the program data currently- displayed in the specified file.

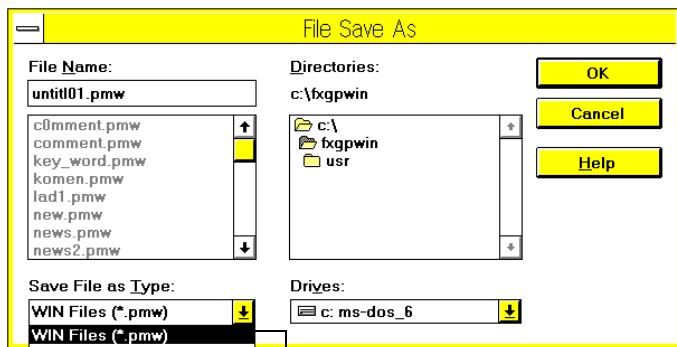

Stores data in the DOS type file

Stores data in the FXGP/WIN-E type file.

- To store the data, specify the drive and directory.
- Enter the file name using the keyboard, or select a file name from the list of existing files.
- If you want to store the file in a new directory (folder), enter the new directory (folder) name in the File Name box together with the file name. The directory you specified will be newly created, and the file will be stored in the new directory using the file name you entered.

Example: C:\DATA1\TEST.PMW

If a directory non-existing on the C drive is specified, the directory will be newly created.



You can use up to 32 characters to specify the program title.

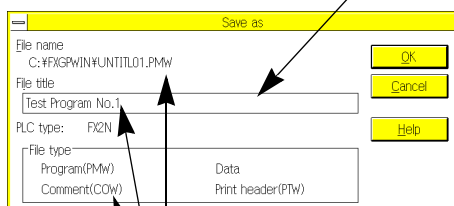

The name of the file to be stored, programmable controller type, and the other files stored at the same time will be displayed.

Files to be stored at the same time

- Store the program data in a *.PMW type file by executing the Close and Open, Save, and Save As commands. All the related files will be newly created or updated.
- Files to be stored

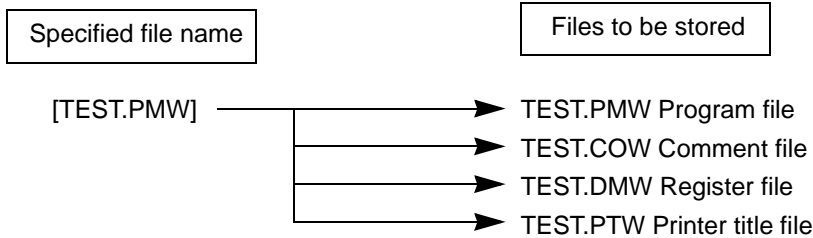

As described above, if you specify TEST.PMW and then execute Save, four files shown above will be newly created or updated at the same time. For this reason, always specify the *.PMW type even if you want to store a file other than the program file, such as the comment file or register file.

To save the sampling trace file (*.STW), sequentially click PLC, Sampling Trace, and then Write to Result File.

5.1.6 Print

OPN	L/V	L/M	I/V	S/V	S/M
	✓		✓	✓	
—	C/V	R/V	D/L	D/M	SMP
	✓	✓	✓	✓	✓

When you click the Print command, the data in the currently-active window will be printed. Therefore, if you click the Print command when the ladder diagram edit window is active, the ladder diagram will be printed. If you print two or more items, such as the ladder diagram, instruction list, device use list, etc., click Print All.

Relation between active window and items to be printed

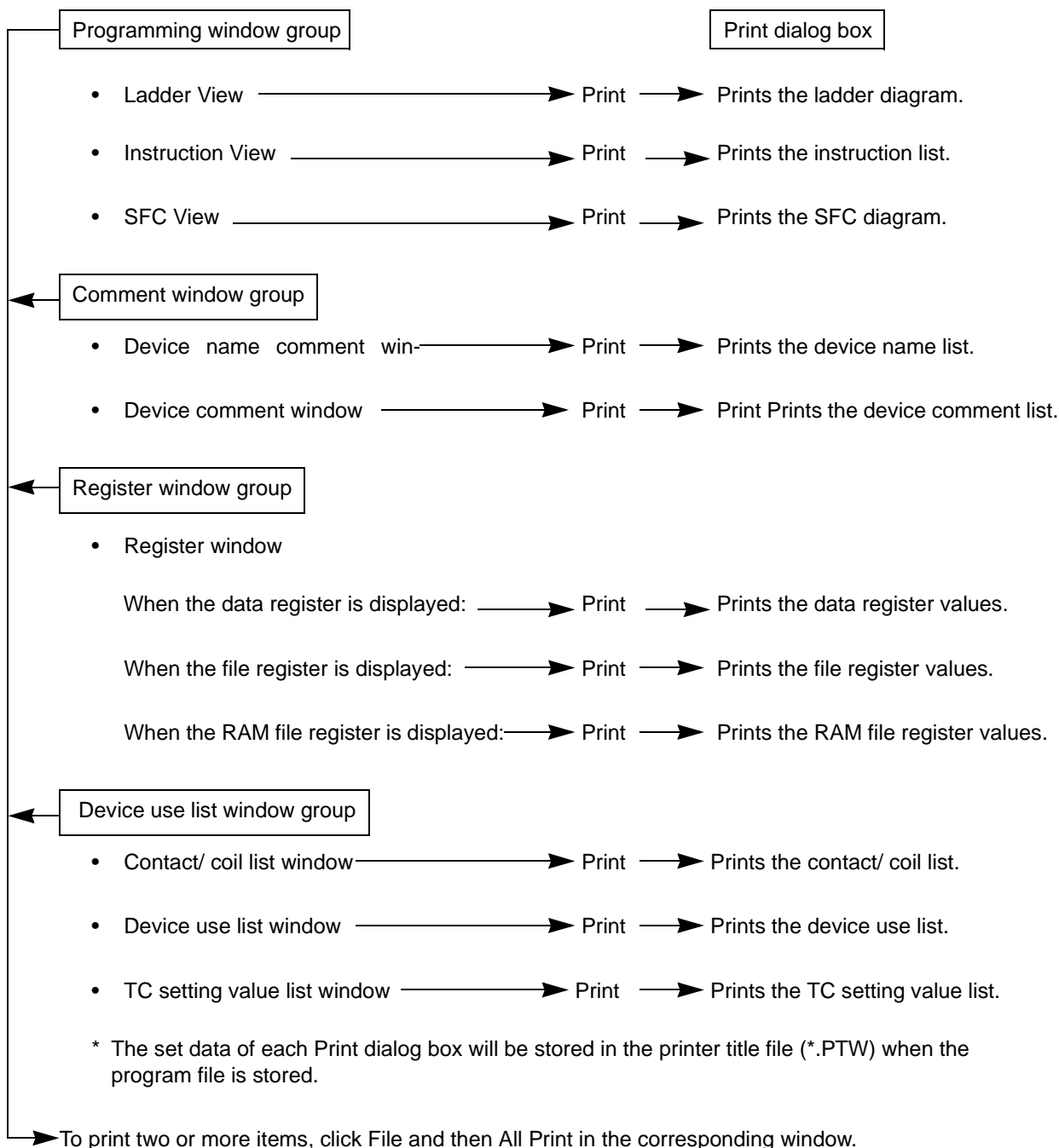

Printing ladder diagram

This section describes how to print sequence programs using the format of ladder diagrams. When the ladder diagram edit window is active, execute File and then Print.

Set the comment type to be printed.

(1) →

Specify the contact-use devices for printing.

Specify the coil- use devices for printing.

Click this button to reduce the line spacing. The printing area of each page will be increased.

Click this button to print the title setting page. Before printing, set the title setting page by clicking Option and then Printer Title.

Click this button to print the parameter setting page. Before printing, set the parameter setting page by clicking Option and then Parameter Setting.

Starts printing.

Reads out the comment display data set in the program edit window.

Displays the image of the printed document on the preview screen.

Specify the program step printing range.

Specify the printing size. As the printing size, you can specify "Auto" or percentage between "50% and 150%" (in increments of 5%). If you specify Auto, the number of characters in one line will be automatically adjusted depending on the width of the specified printing sheet.

(1) →

Specify the comment type to be added to the ladder diagram.

Select the device comment printing position; above or below the device symbol.

Set the device comment display size. If the size is set as shown in the figure, the device comment of 10 characters × 5 lines will be printed.

Set the coil comment display size. If the size is set as shown in the figure, the coil comment of 20 characters × 7 lines will be printed.

Click Copy Settings on the previous screen to display this screen. This screen displays the comment display data set in the program edit window.

Printing instruction list

This section describes how to print sequence programs using the format of instruction list. When the list edit window is active, execute File and then Print.

Set the comment type to be printed.

(2) ←

Specify the program step printing range. →

Click this button to print the parameter setting page. Before printing, set the parameter setting page by clicking Option and then Parameter Setting.

Click this button to print the title setting page. Before printing, set the title setting page by clicking Option and then Printer Title.

Starts printing. ← OK

Reads out the comment display data set in the program edit window. ← Copy settings

Displays the image of the printed document on the preview screen. ← Preview

Specify the printing size. As the printing size, you can specify "Auto" or percentage between "50% and 150%" (in increments of 5%). If you specify Auto, the number of characters in one line will be automatically adjusted depending on the width of the specified printing sheet.

(2) ←

Specify the comment type to be added to the program list. →

Unused ←

Click Copy Settings to display the comment display data set in the program edit window.

Printing SFC diagram

This section describes how to print sequence programs using the format of SFC diagrams. When the SFC diagram edit window is active, execute File and then Print.

Set the comment type to print the SFC diagram.

Click this button to print the state internal circuit using the format of the ladder diagram. (3)

Set the internal circuit printing data.

Starts printing.

Reads out the comment display data set in the program edit window.

Displays the image of the printed document on the preview screen.

Click this button to reduce the line spacing. The printing area of each page will be increased. (4)

Specify the printing size. As the printing size, you can specify "Auto" or percentage between "50% and 150%" (in increments of 5%). If you specify Auto, the number of characters in one line will be automatically adjusted depending on the width of the specified printing sheet.

Click this button to print the parameter setting page. Before printing, set the parameter setting page by clicking Option and then Parameter Setting.

Click this button to print the title setting page. Before printing, set the title setting page by clicking Option and then Printer Title.

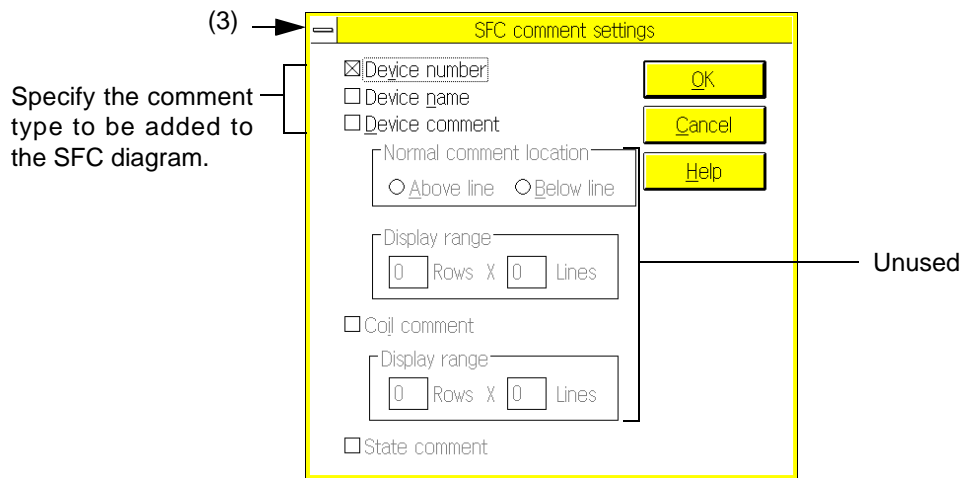

Click Copy Settings on the previous screen to display this screen. This screen displays the comment display data set in the SFC program edit window.

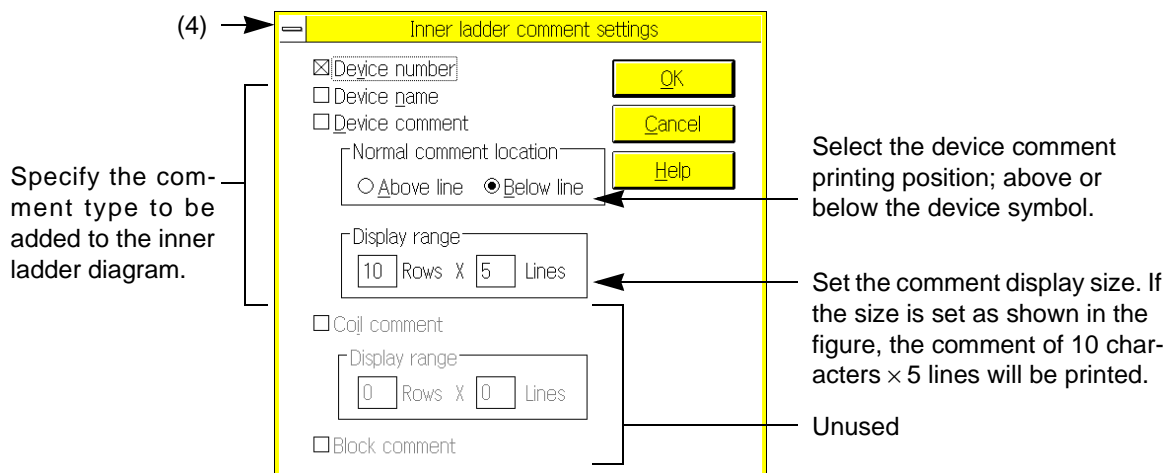

Click Copy Settings on the previous screen to display this screen. This screen displays the comment display data set in the inner ladder diagram edit window.

Printing Device comment / Device names

This section describes how to print the list of Device comment / Device name. When the device name window is active, execute File and then Print.

The screenshot shows a dialog box titled "Device comment" with the following elements and annotations:

- Range:**
 - All range: Annotated with "Specify the device printing range."
 - Setting range: A sub-section containing checkboxes for X, Y, M, S, T, C, D, P, I, each followed by a range input field.
- Only print used devices: Annotated with "Click this button not to print the devices unused in the program."
- Title: Annotated with "Click this button to print the title setting page. Before printing, set the title setting page by clicking Option and then Printer Title."
- Parameter settings list: Annotated with "Click this button to print the parameter setting page. Before printing, set the parameter setting page by clicking Option and then Parameter Setting."
- 2 lines: Annotated with "Click this button to use 2 lines for printing."
- Scale:** A dropdown menu currently set to "AUTO", annotated with "Specify the printing size. As the printing size, you can specify 'Auto' or percentage between '50% and 150%' (in increments of 5%). If you specify Auto, the number of characters in one line will be automatically adjusted depending on the width of the specified printing sheet."
- Buttons:**
 - OK: Annotated with "Starts printing."
 - Cancel: Standard cancel button.
 - Help: Standard help button.
 - Preview: Annotated with "Displays the image of the printed document on the preview screen. Click this button to use 2 lines for printing."

Printing contact/coil list

This section describes how to print the contact/ coil list. The list shows the program steps that use contacts or coils of devices.

When the contact/ coil list window is active, execute File and then Print.

Specify the device printing range.

Click this button not to print the devices unused in the program.

Click this button to print the parameter setting page. Before printing, set the parameter setting page by clicking Option and then Parameter Setting.

Click this button to print the title setting page. Before printing, set the title setting page by clicking Option and then Printer Title.

Starts printing.

Displays the image of the printed document on the preview screen.

Click the desired button in this box to print the comments added to the respective device numbers.

Specify the printing size. As the printing size, you can specify "Auto" or percentage between "50% and 150%" (in increments of 5%). If you specify Auto, the number of characters in one line will be automatically adjusted depending on the width of the specified printing sheet.

Printing device use list

This section describes how to print the device use list. The list shows whether the contacts and coils of devices are used in the program.

When the device use list window is active, execute File and then Print.

To set data in the device use list printing dialog box, refer to "Printing contact/ coil list" described above.

Printing TC setting list

This section describes how to print the TC setting list. The list shows the timer/ counter setting values set in the program.

When the TC setting list window is active, execute File and then Print.

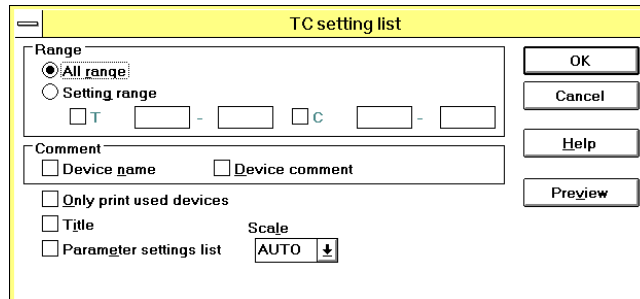

To set data in the TC setting list printing dialog box, refer to "Printing contact/ coil list" described above.

Printing Register list

You can print the list of current register values.

To print this list, activate the data register window. While displaying the data register window, click File and then Print.

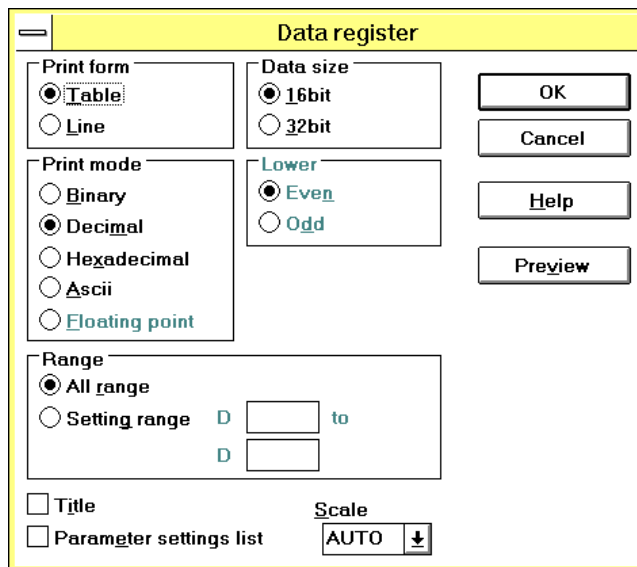





To set the printing data in this window, refer to the data setting method described in Sec. 5.5.6 "Register View".

5.1.7 Print All

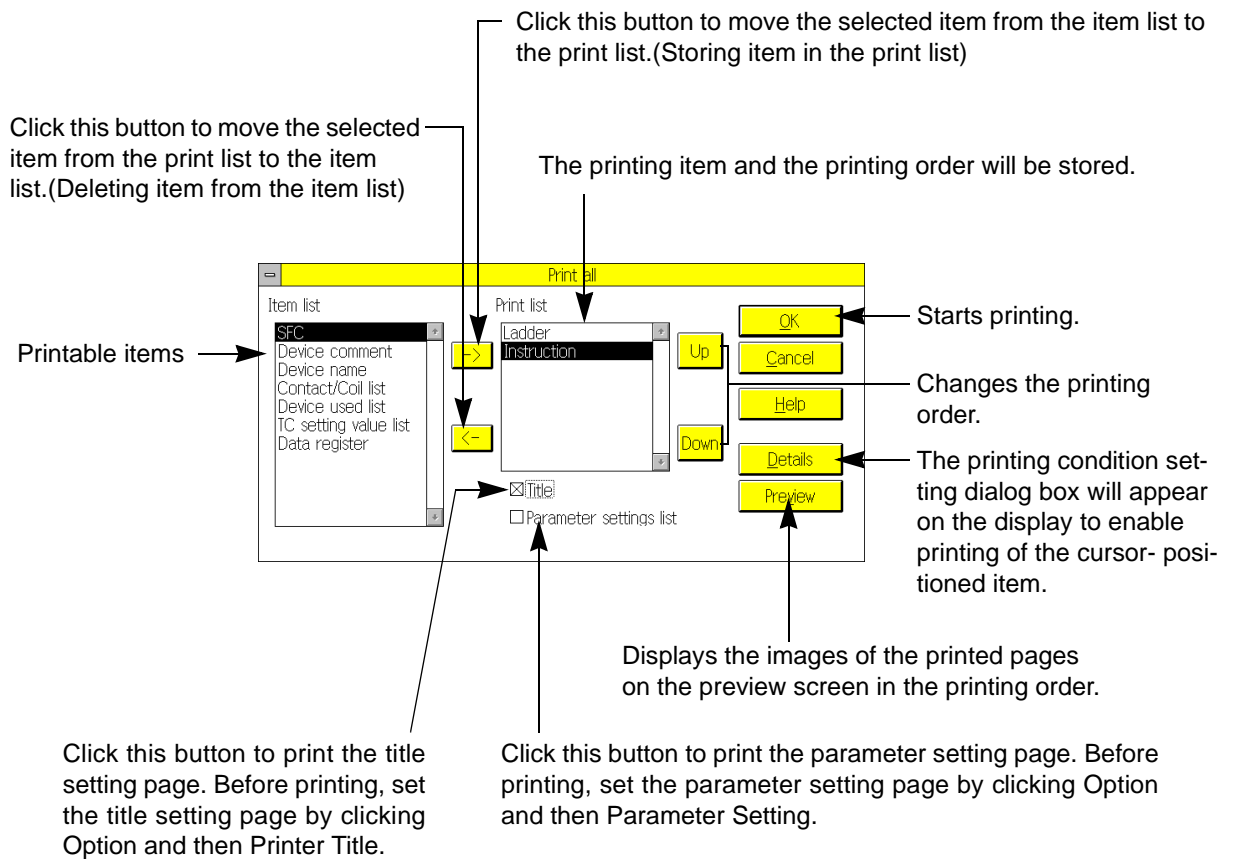
OPN	L/V	L/M	I/V	S/V	S/M
	✓		✓	✓	
—	C/V	R/V	D/L	D/M	SMP
	✓	✓	✓	✓	✓

The Print command described in the previous section is valid only for the active window. The Print All command described in this section, however, can print all the specified items in the specified order while ignoring the active window. Execute File and then Print All. You can execute these commands in any edit window.



- To store a printing item in the print list, position the cursor on the desired item in the Item List box. After that, click  to move the item to the Print List box.
- To delete an item from the print list, position the cursor on the item in the Print List box. After that, click  to delete the item from the print list and move it to the Item List box.
- The items will be printed in the order of items set in the Print List box. To change the order of items in the Print List box, position the cursor on the desired item, and then click the  or  button. The cursor- positioned item will be moved up or down in the box to change the item order.

5.1.8 Page Setup

OPN	L/V	L/M	I/V	S/V	S/M
✓	✓		✓	✓	
—	C/V	R/V	D/L	D/M	SMP
	✓	✓	✓	✓	✓

Use this command to set the page before printing. For example, you can set the margin, header, footer, and page number printing position.

To set the paper size and printing direction, use the Printer Setup command.

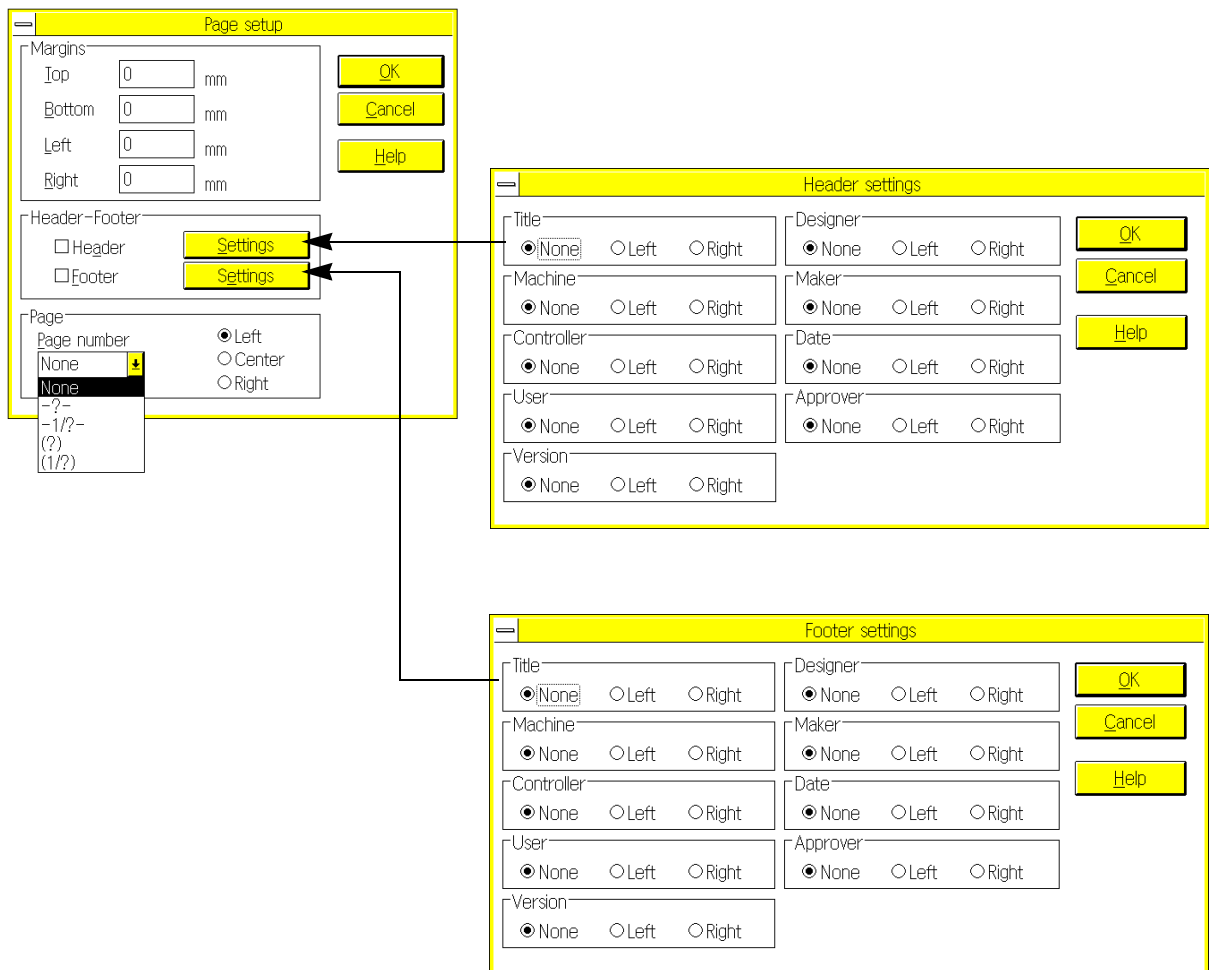

Set the header and footer data in the header and footer data windows, and then execute Option and Printer Title.

The header and footer will be printed at the upper and lower sections of the page as specified in the respective windows.

5.1.9 Print Preview

OPN	L/V	L/M	I/V	S/V	S/M
	✓		✓	✓	
—	C/V	R/V	D/L	D/M	SMP
	✓	✓	✓	✓	✓

Use this command to display the image of the printed document on the preview screen. The image shown on the preview screen depends on the data set in the printing condition setting dialog box, Page Setup window, and Printer Setup window. To call up the preview screen, open the related window, and then execute File and Print Preview.

Click this button to open the printing condition setting dialog box of the corresponding work window.

Click this button to go to the next page.

Click this button to go to the previous page.

Switches the number of pages displayed on the screen. You can select 1 page or 2 pages.

Click this button to enlarge the screen.

Click this button to reduce the screen.

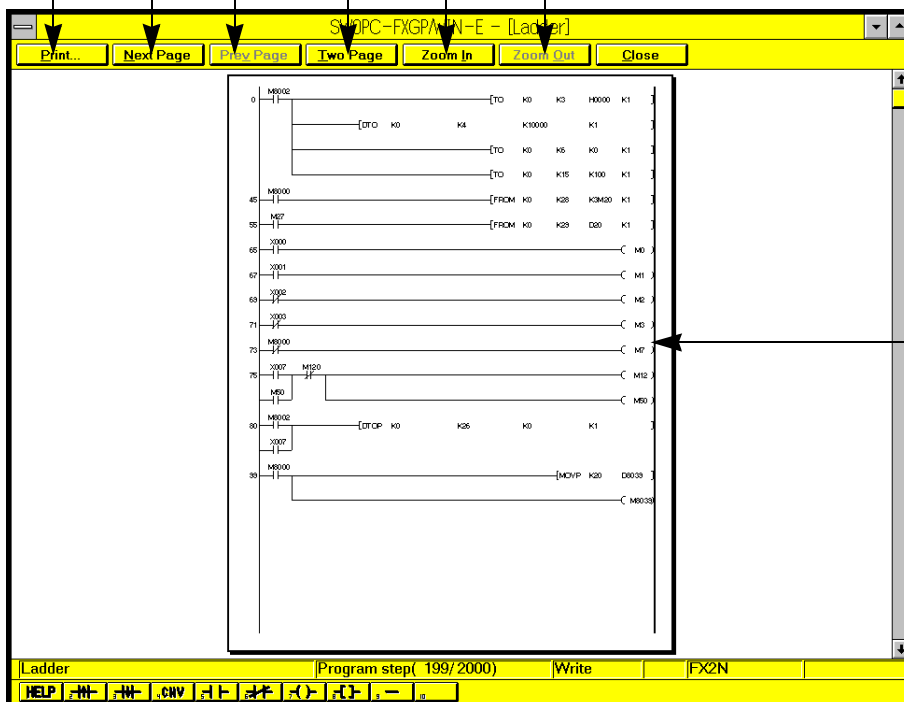

Displays the image of the printed document on the screen.



- You can also call up the preview screen after executing Print and then Print All.
- If the preview screen reveals that the paper size is too small to contain all the data, adjust the page data as follows:

Execute Page Setup to open the Page Setup window, and then adjust the margins.

Execute Printer Setup to open the Printer Setup window, and then adjust the paper size and printing direction.

Open the printing condition setting dialog box of the corresponding item, and then adjust the zoom rate.

5.1.10 Printer Setup

OPN	L/V	L/M	I/V	S/V	S/M
✓	✓		✓	✓	
—	C/V	R/V	D/L	D/M	SMP
	✓	✓	✓	✓	✓

Use this command to set the printer type, paper size, and printing direction.

Displays the main printer set by the Windows control panel.

You can select any printer from those stored in Windows.

Select the printing direction.

Specify the paper size and paper feed method.

Click this button to open the detailed printer data setting dialog box. Data setting depends on the printer. Refer to the instruction manual of the printer to set data.

5.1.11 Displaying file use history

OPN	L/V	L/M	I/V	S/V	S/M
✓	✓	✓	✓	✓	✓
—	C/V	R/V	D/L	D/M	SMP
	✓	✓	✓	✓	✓

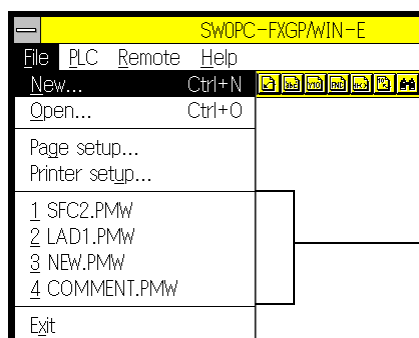

Click File to display the file use history. Four files previously used will be displayed in the order of time elapsing. Click one of these files, to directly open the file.

5.1.12 Exit

OPN	L/V	L/M	I/V	S/V	S/M
✓	✓	✓	✓	✓	✓
—	C/V	R/V	D/L	D/M	SMP
	✓	✓	✓	✓	✓

Use this command to exit from the FXGP/WIN-E.

Select File and then Exit to exit from the FXGP/WIN-E.

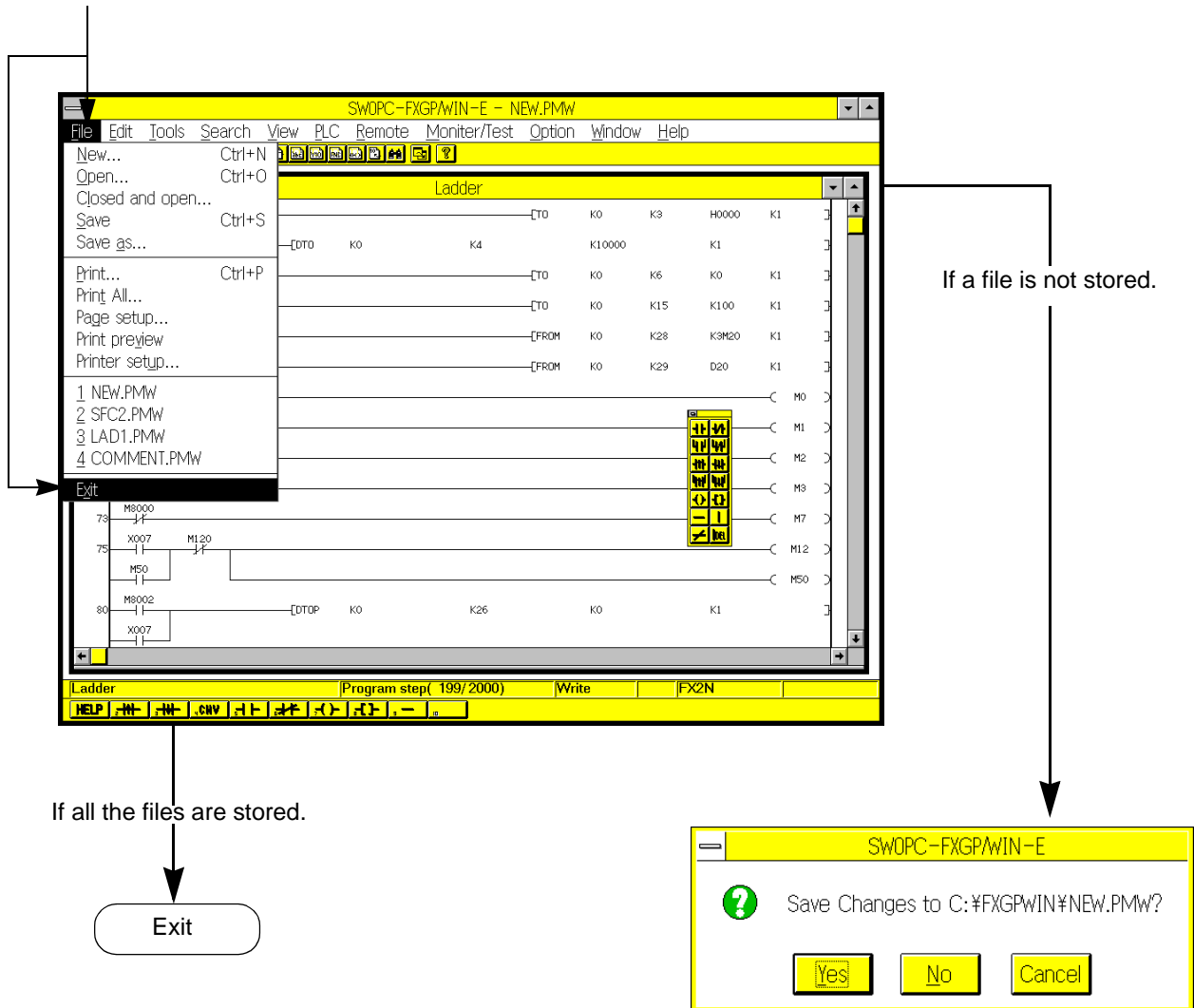

- The FXGP/WIN-E can open two or more application windows. Note that the Exit command is valid only for the application window currently active. If two or more sequence programs are activated, sequentially end the programs by sequentially activating the application windows.

MEMO

5.2 Edit Menu Functions

The Edit menu has various commands as shows below. Note that the function of the same command may be changed when the active window is switched.

- (1) Cut-and-paste function used for ladder diagrams, instruction lists, etc.
- (2) Character string cut-and-paste function used for comments
- (3) Line insert and delete functions used for ladder diagrams
- (4) All edit function for NOP instruction in editing list
- (5) Comment store and edit functions

OPN	L/V	L/M	I/V	S/V	S/M
	✓		✓	✓	
—	C/V	R/V	D/L	D/M	SMP
	✓	✓			

5.2.1 Undo

Undoes the last operation to return to the previous condition.

Note that you cannot undo the circuit conversion operation, circuit block delete operation, etc. In the other windows, some types of operations cannot be undone, either.

5.2.2 Cut

Cuts out the selected programs or characters.

The cut programs or characters will be stored in the clip board. You can, therefore, paste the cut programs or characters on another place.

5.2.3 Copy

Copies the selected programs and characters to the Windows clip board.

The copied data can be pasted on another place using the Paste command.

5.2.4 Paste

Pastes the programs and characters on the cursor position only if the data is stored in the Windows clip board by executing the Cut or Paste command.

5.2.5 Delete

Deletes the selected programs and characters.

The deleted data will not be stored in the Windows clip board. For this reason, the Paste command will not be valid for the deleted data.



- The following command will not be valid in some windows.

Undo : Not valid in the SFC diagram edit windows.

Copy : Not valid in the device name comment window and SFC diagram edit windows.

Cut : Not valid in the SFC diagram edit window.

Paste : Not valid in the SFC diagram edit window.

5.2.6 Line Delete

OPN	L/V	L/M	I/V	S/V	S/M
	✓				
—	C/V	R/V	D/L	D/M	SMP

Use this function to delete the right side of the cursor position. After deleting, enter new program in the null section, or edit the circuit so that the circuit block is valid. After that, click Convert.

Note that this command cannot be used for any one-line circuit block in the program step-completed status. To delete such one-line circuit block, two or more circuits, or two or more circuit blocks, use the Block Select command described later, and then execute Delete.

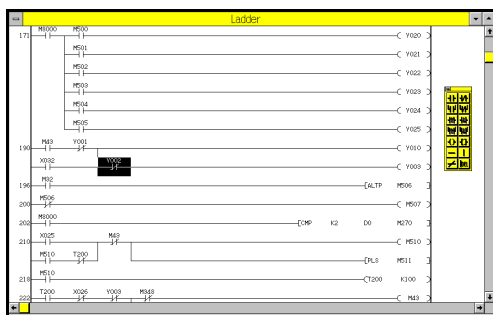

Position the cursor at any position on the line you would like to delete.



Execute Edit and then Line Delete.

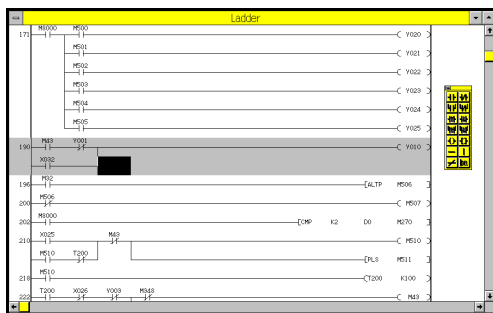

In this condition, execute Tools and then Convert if your purpose is only the line delete. If the circuit is not complete, complete the circuit first, and then execute Tools and then Convert.



The circuit will be determined after conversion.



Remedy for circuit conversion error

If a circuit error is detected after executing circuit conversion, correct the circuit, and then convert the circuit to determine the circuit program.

To delete the circuit data you edited and to cancel the ladder diagram editing mode, click Edit and then Edit Cancel. Or execute Edit Cancel using the right button of the mouse. Note that after executing Edit Cancel, all the circuit data you edited in the ladder diagram window will be deleted if the data is not converted.

5.2.7 Line Insert

OPN	L/V	L/M	I/V	S/V	S/M
	✓				
—	C/V	R/V	D/L	D/M	SMP

Use this command to insert null line above the specified line.

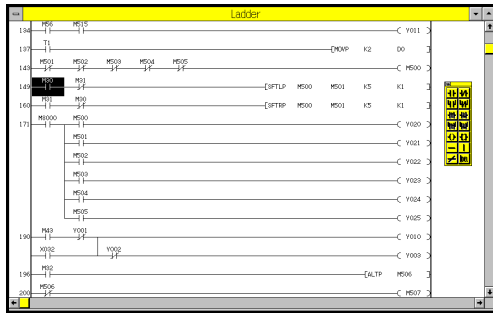

Position the cursor on a line. A null line will be inserted just above the cursor-positioned line.



Execute Edit and then Line Insert.

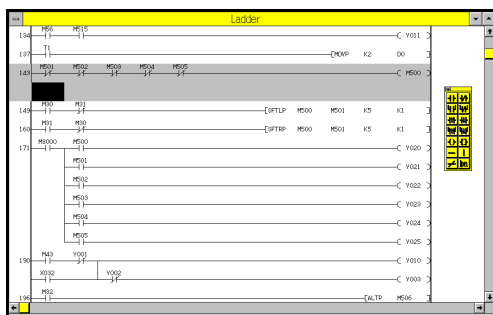

A null line will be inserted just above the cursor-positioned line. To insert two or more null lines, repeatedly execute Line Insert.



Enter a necessary circuit in the null line, and then execute Tools and then Convert. The circuit will be determined after conversion.



Line insert into step 0

If a null line is in front of step 0 or at the top line of the circuit program, be sure to enter new program there, and then convert the ladder diagram of the circuit.
 If there is a null section, execution of conversion will cause a circuit error. If a circuit error is displayed after conversion, click the control menu box at the upper left corner of the window to close the window, and then open the window to display the ladder diagram again.
 Be careful! When you close the ladder diagram window, all the edited data will be erased if they are not converted.

5.2.8 Block Select

OPN	L/V	L/M	I/V	S/V	S/M
	✓				
—	C/V	R/V	D/L	D/M	SMP

Use this command to specify a circuit block above or below the cursor position.

This command can be also executed using the **↑Shift** + **↑**/**↓** keys or **↑Shift** keys + mouse dragging.

For the specified block, the following commands will be valid:

- Edit → Cut : Cuts out the specified block, and then stores it in the clip board.
- Edit → Copy : Copies the specified block in the clip board.
- Edit → Delete: Deletes the specified block.

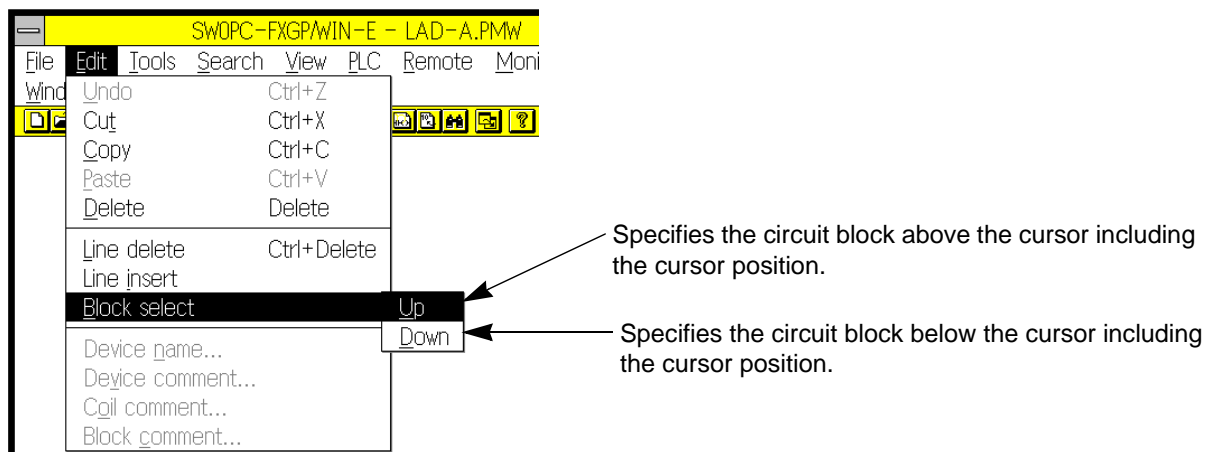

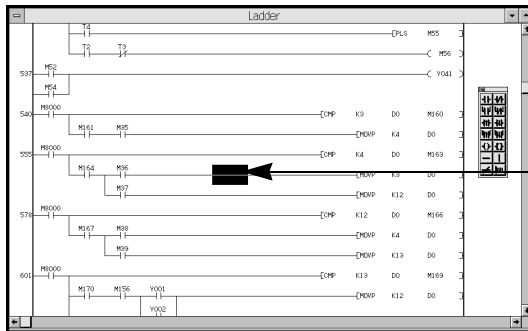

Position the cursor on a line to specify a block.



Execute Up.

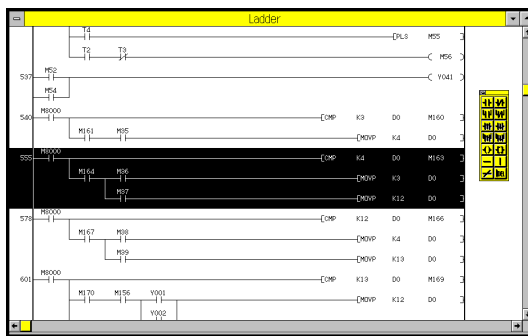

The cursor-positioned block will be specified.



Execute Up again.

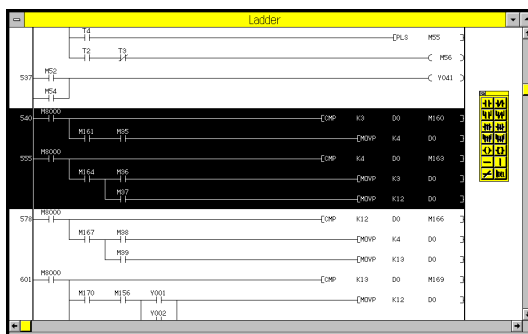

The block just above the currently-specified block will be added to the currently-specified block. Repeatedly execute the Up command, to increase the specified block area in the upper direction (lower direction if the Down command is executed).



At the completion of block specification, execute Cut, Copy, or Delete command.

When the Cut or Delete command is executed, the cut or deleted result will be stored in the program software, therefore it is not necessary to convert the program.

5.2.9 NOP Overwrite

OPN	L/V	L/M	I/V	S/V	S/M
			✓		
—	C/V	R/V	D/L	D/M	SMP

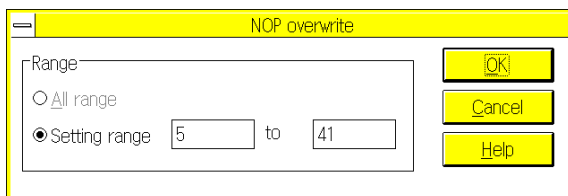

Use this command to overwrite the NOP instructions in the specified range of steps at a time. All the instructions currently stored in the specified range will be replaced with the NOP instructions.

5.2.10 NOP Insert

OPN	L/V	L/M	I/V	S/V	S/M
			✓		
—	C/V	R/V	D/L	D/M	SMP

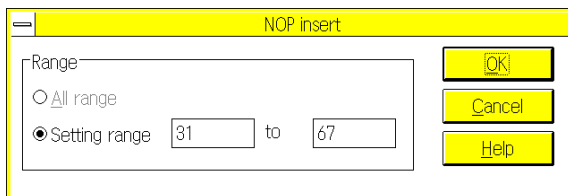

Use this command to insert the NOP instructions in the specified range of steps. When the NOP instructions are inserted, the instructions currently set in the specified range will be shifted in the lower direction depending on the specified number of steps. In addition, the block and coil comments will be shifted following the instructions. If the number of steps exceeds the specified upper limit number, insertion of NOP instructions will not be possible.

5.2.11 NOP Remove

OPN	L/V	L/M	I/V	S/V	S/M
			✓		
—	C/V	R/V	D/L	D/M	SMP

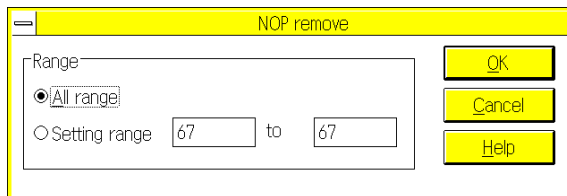

Use this command to erase all the NOP instructions from the entire program area or the specified range of the steps. The non- erased instructions will be shifted in the upper direction.

The step numbers of the non-erased instructions will be reduced depending on the number of erased steps.

In addition, the block and coil comments will be also shifted following the shifted instructions.



Range specification using cursor for NOP Overwrite, NOP Insert, and NOP Remove. If you specify the step range using the cursor on the list edit screen, the specified step range will be automatically displayed in the Setting Range box of the corresponding dialog box.

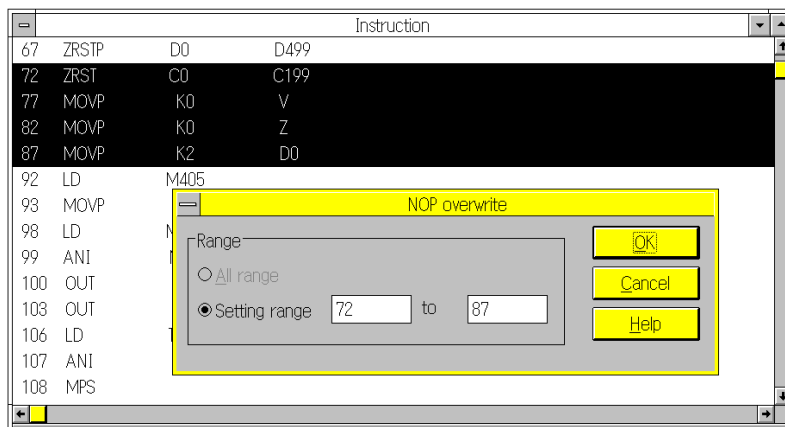

5.2.12 Device Name

OPN	L/V	L/M	I/V	S/V	S/M
	✓			✓	
—	C/V	R/V	D/L	D/M	SMP

Use this command to store the name of the cursor-positioned device.
 To store a device name, position the cursor on the device in the ladder diagram display window, and then execute Edit and then Device Name.

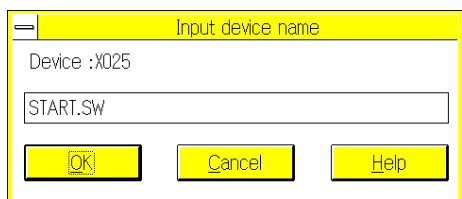

- Number of characters: Up to 8 characters can be used for the device name.
- Character type: Alphanumeric characters and symbols (+ - * / = . ? # \$ % & ; : ; _)
- Applicable devices: X, Y, M, S, T, C, D, P, and I.

When you are programming, device names can be used in place of the device numbers, such as X000 and M10. For this reason, use of the same names for two or more devices will not be possible.
 You can also store the device name by sequentially executing View, Comment View, and then Device Name.

5.2.13 Device Comment

OPN	L/V	L/M	I/V	S/V	S/M
	✓			✓	
—	C/V	R/V	D/L	D/M	SMP

Use this command to store the device comments for the cursor- positioned device.
 To store a device comment, position the cursor on the device in the ladder diagram display window, and then execute Edit and then Device Comment.

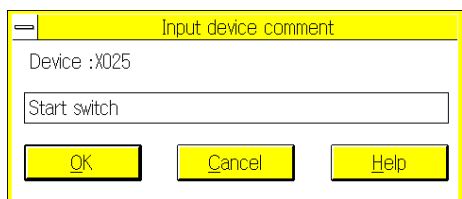

- Number of characters: Up to 50 characters can be used for the device comment.
- Applicable devices: X, Y, M, S, T, C, D, P, and I.

This command can store the device comments controlled by the peripheral units, but cannot store the parameter-set comments to be stored in the program memory of the programmable controller (see Sec.1.3). For the special auxiliary relays and special data registers, the comments on their functions will be stored preliminarily.
 You can also store the device comments by sequentially executing View, Comment View, and then Device Comment.

The device comments stored by this command are controlled by the peripherals. However, these device comments can be written in the parameter-set comment area of the program memory in the programmable controller.

To enter a comment to be written in the programmable controller, be sure to read the following description, Sec. 1.4 "Comment Control", and Sec. 5.3.9 "Setting of comment move to PLC".



Device comment and Device name

- You can add device comments to the devices of the programmable controller, and can use the device comments when they are displayed in the programs or printed.

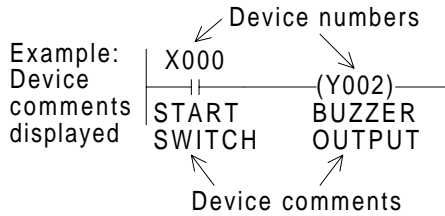

- You can also add device names to the devices. The device names can be used in the programs in place of the device numbers.

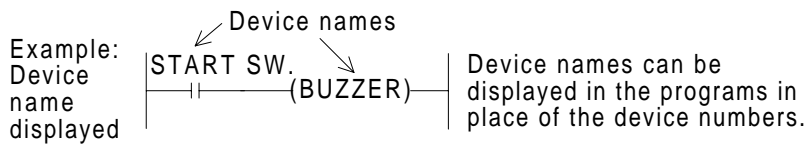

Device names and device comments are added to the device numbers. For this reason, when a step is subject to change or the cut-and-paste command is executed, device names and comments will be erased or moved together with the respective device numbers.

5.2.14 Coil Comment

OPN	L/V	L/M	I/V	S/V	S/M
	✓				
—	C/V	R/V	D/L	D/M	SMP

Use this command to store coil comments for the cursor- positioned output instructions and application instructions.

To store a coil comment for an output or application instruction in the ladder diagram edit window, position the cursor on the instruction or in front of the instruction, and then execute Edit and then Coil Comment.

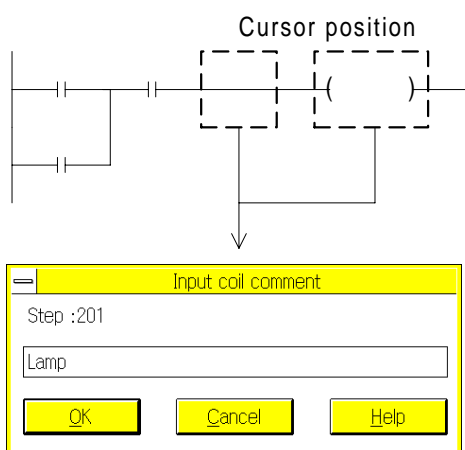

- To store a coil comment, you can use any number of characters and any character type.
- You can enter coil comments at the completion of circuit conversion. If circuit conversion is not complete, no coil comment can be entered.
- To copy a coil comment, specify the copy range and then execute Ctrl+C (cut). After that, execute Ctrl+V (paste) in the copy-to comment dialog box.

5.2.15 Block Comment

OPN	L/V	L/M	I/V	S/V	S/M
	✓				
—	C/V	R/V	D/L	D/M	SMP

Use this command to store block comments for the cursor-positioned circuit block.

To store a block comment for a circuit block in the ladder diagram edit window, position the cursor at any position of the circuit block, and then execute Edit and then Block Comment.

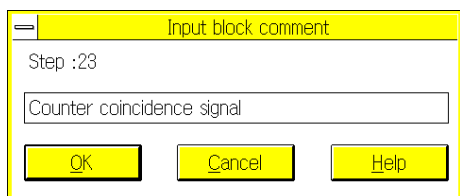

- To store a block comment, you can use any number of characters and any character type.
- You can block coil comments at the completion of circuit block conversion. If circuit block conversion is not complete, no coil comment can be entered for the circuit block.
- To copy a block comment, specify the copy range and then execute Ctrl+C (cut). After that, execute Ctrl+V (paste) in the copy-to comment dialog box.



Coil comment and block comment

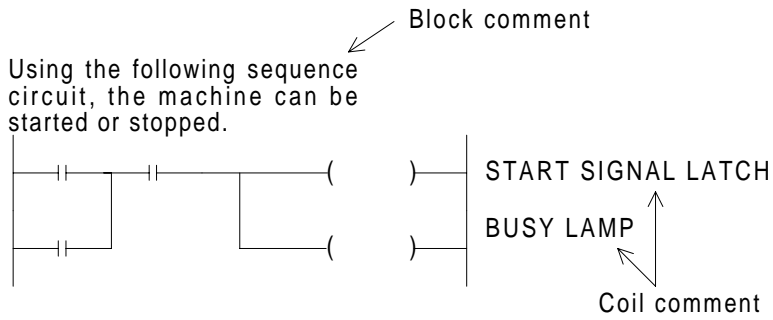

Coil and block comments can be added to step numbers if the steps include the corresponding coils or blocks. For this reason, if a step is subject to change due to coil or block insertion or deletion, the corresponding coil or block comment will be also inserted or deleted. In addition, if an instruction step or circuit block itself is deleted, the comments stored in the step or block will be also deleted at the same time.

5.2.16 Device Registration

OPN	L/V	L/M	I/V	S/V	S/M
—	C/V	R/V	D/L	D/M	SMP
				✓	

Use this command to store device numbers in the device store/monitor screen. To store a device number, position the cursor at a desired position on the device monitor screen, and then execute Edit and then Device Registration. The device number will be stored in the cursor position on the screen.

Enter the device number to be stored, changed, or deleted.

Click this button to delete all the device numbers currently stored.

Click this button to store the device number in the monitor screen.

Deletes the device number from the Device box. The data set in the Number of Devices box, however, will not be deleted.

You can store two or more device numbers starting from the number set in the Device box. Data entry range: 1 to 48.

5.2.17 Edit cancel

OPN	L/V	L/M	I/V	S/V	S/M
	✓				
—	C/V	R/V	D/L	D/M	SMP

Use this command to delete the circuit data you edited in the ladder diagram window.

Before editing

(The circuit data is already converted, therefore the circuit is determined.)

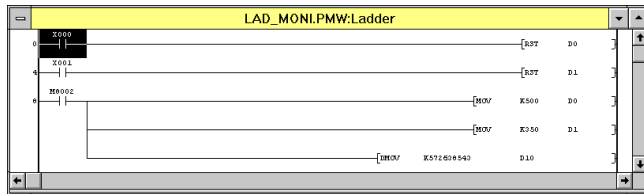

Editing ladder diagram

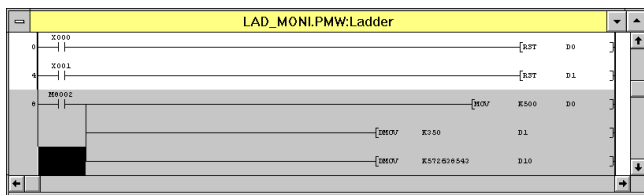

Click Edit and then Edit Cancel.

After edit cancel

(The ladder diagram will return to the pre-editing condition.)

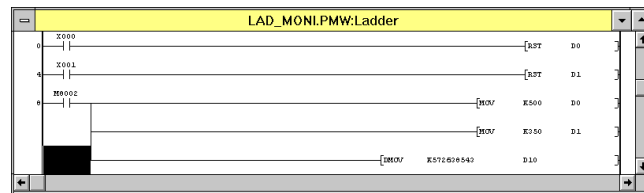

5.3 Tools Menu Functions

Use the commands on the Tools menu to enter symbols in ladder or SFC diagrams or to convert circuit blocks in the diagrams.



If you prefer keyboard operation, use functions keys having the same functions as the Tools menu commands. Circuit symbols, instructions, and SFC diagrams are allocated to the functions keys, and these functions of keys depend on the edit window.

Function keys in ladder diagram edit window

The screenshot shows the GX Developer software window titled "SWOPC-FXGPWIN-E - COMMENT.PMW". The main window displays a ladder diagram with rungs 0 through 36. A floating tool box is overlaid on the diagram, containing a grid of circuit symbols and instructions such as CT10, K200, D20, K1800, D1, SSET, M30, PLS, M95, MC, NO, M50, MCR, NO, ECJ, PO, Y020, Y021, Y022, and Y023. An arrow labeled "Floating tool box" points to this grid. Below the main window, a keyboard function key strip is shown, with arrows pointing from labels "Convert key" and "Circuit symbol entry key" to specific icons in the strip. The strip includes a "SHIFT" key followed by keys numbered 1 through 10, each with a unique circuit symbol icon.

5.3.1 Contact

OPN	L/V	L/M	I/V	S/V	S/M
	✓				
—	C/V	R/V	D/L	D/M	SMP

Use this command to enter the a-contact and b-contact.

Note that this command has the same function as function keys **F5** (-|I-), **F6** (-I/I-), **F2** (-I↑I-), and **F3** (-I↓I-).

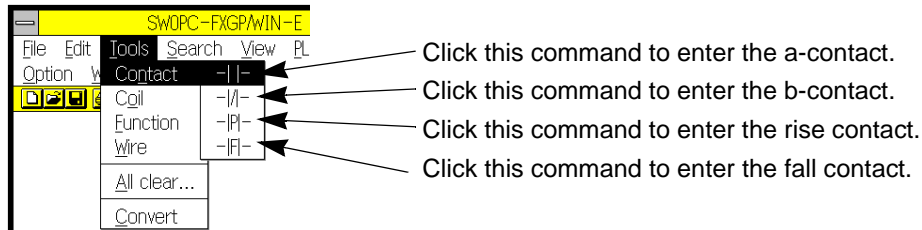

Applicable devices X (input relay) M (auxiliary relay) T (timer)
 Y (output relay) S (state) C (counter)

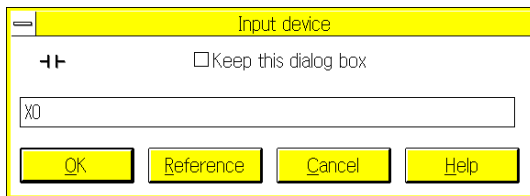

Entering a-contact

Enter the device symbol and the device number.

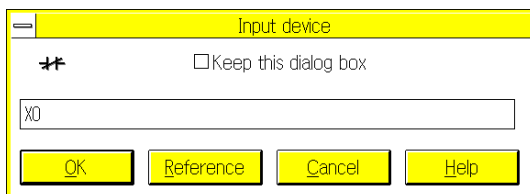

Entering b-contact

Enter the device symbol and the device number.

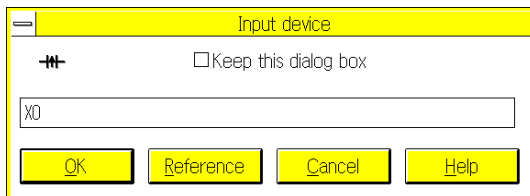

Entering rise contact

Enter the device symbol and the device number.

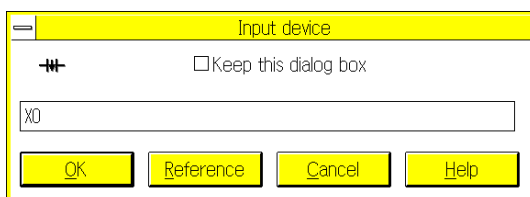

Entering fall contact

Enter the device symbol and the device number.



Entering contacts using Reference command

Click the Reference command. The following dialog box will appear on the display. In this dialog box, the device names already stored will be displayed. Click a device name using the mouse button to enter the device.

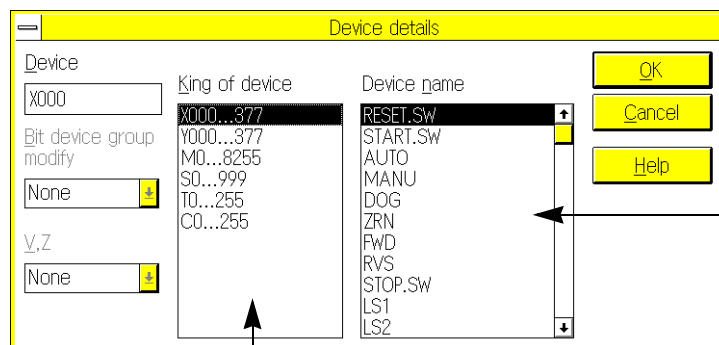

Shows the devices names already stored. Click the mouse button on a device name to enter the device.

Switch the device type

5.3.2 Coil

OPN	L/V	L/M	I/V	S/V	S/M
	✓				
—	C/V	R/V	D/L	D/M	SMP

Use this command to enter output coil instructions.

Note that this command has the same function as function key **F7** (-(-)).

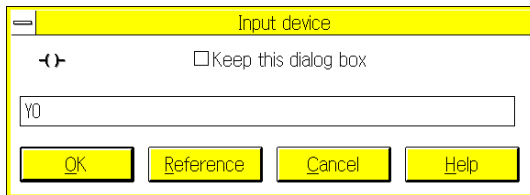

Entering bit device

Applicable devices:

- Y (output relay)
- M(auxiliary relay)
- S (state)

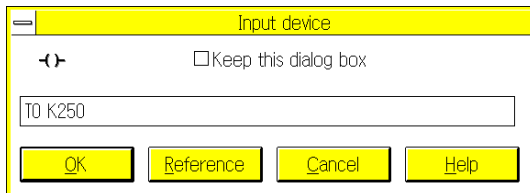

Entering timer and counter

Applicable devices:

- T (timer)
- C (counter)

Formats for data entry:

- T0[space] K*** (Specifies a contact.)
- T3[space] D*** (Specifies an interval.)
- C5[space] K*** (Specifies a constant.)

- You can also use device names in place of the device numbers (see Sec.6.2 and the following Note).
- Use the Function command (as described in Sec.5.3.3) to enter the following special coil instructions:
 SET/RST PLS/PLF
 MC/MCR STL/RET END



Entering coils using Reference command

Click the Reference command. The following dialog box will appear on the display. In this dialog box, the device names already stored will be displayed. Click a device name using the mouse button to enter the device.

Enter a device number, such as T* and C*, in this box. Direct entry is also possible.

Enter a constant, such as K** and D**, in this box. Direct entry is also possible.

Switch the devise type.

Shows the devices names already stored. Click the mouse button on a device name to enter the device.

5.3.3 Function

OPN	L/V	L/M	I/V	S/V	S/M
	✓				
—	C/V	R/V	D/L	D/M	SMP

Use this command to enter application instructions and special coil instructions.

Note that this command has the same function as function key **F8** (- [] -).

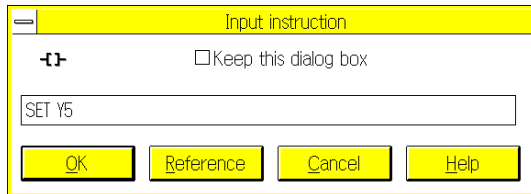

Entering special coil

Applicable instructions:

SET/ RST PLS/ PLF
 MC/ MCR STL/ RET
 END

Formats for data entry:

SET[space] Y5
 PLS[space] M200
 MC[space] N0[space] M30
 STL[space] S20

For the following instructions, it is not necessary to enter device numbers:

RET, END

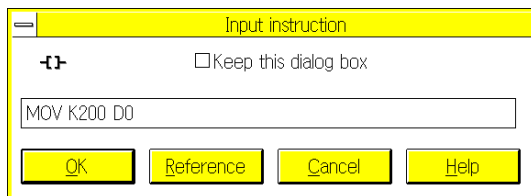

Entering application instructions

Formats for data entry:

MOV[space] K200[space] D0
 (16-bit MOV instruction)

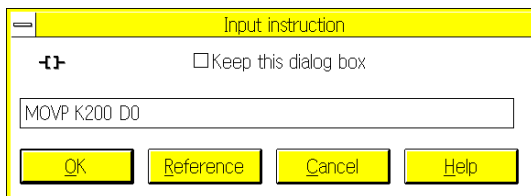

MOVP[space] K200[space] D0
 (16-bit MOV instruction of pulse execution type)

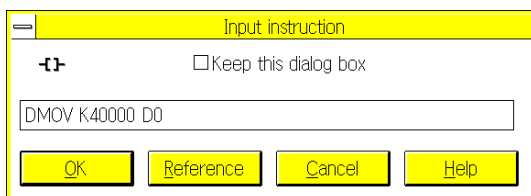

DMOV[space] K40000[space] D0
 (32-bit MOV instruction)

The dialog box has a yellow title bar with the text "Input instruction". Below the title bar, there is a small icon of a double-headed arrow and a checkbox labeled "Keep this dialog box". A text input field contains the instruction "DMOVP K40000 D0". At the bottom, there are four buttons: "OK", "Reference", "Cancel", and "Help".

DMOVP[space] K40000[space] D0
(32-bit MOV instruction of pulse execution type)

The dialog box has a yellow title bar with the text "Input instruction". Below the title bar, there is a small icon of a double-headed arrow and a checkbox labeled "Keep this dialog box". A text input field contains the instruction "FNC12 K200 D0". At the bottom, there are four buttons: "OK", "Reference", "Cancel", and "Help".

FNC12[space] K200[space] D0
(16-bit MOV instruction)

The dialog box has a yellow title bar with the text "Input instruction". Below the title bar, there is a small icon of a double-headed arrow and a checkbox labeled "Keep this dialog box". A text input field contains the instruction "FNC12P K200 D0". At the bottom, there are four buttons: "OK", "Reference", "Cancel", and "Help".

FNC12P[space] K200[space] D0
(16-bit MOV instruction of pulse execution type)

The dialog box has a yellow title bar with the text "Input instruction". Below the title bar, there is a small icon of a double-headed arrow and a checkbox labeled "Keep this dialog box". A text input field contains the instruction "FNC12 K40000 D0". At the bottom, there are four buttons: "OK", "Reference", "Cancel", and "Help".

FNC12[space] K40000[space] D0
(32-bit MOV instruction)

The dialog box has a yellow title bar with the text "Input instruction". Below the title bar, there is a small icon of a double-headed arrow and a checkbox labeled "Keep this dialog box". A text input field contains the instruction "FNC12P K40000 D0". At the bottom, there are four buttons: "OK", "Reference", "Cancel", and "Help".

FNC12[space] K40000[space] D0
(32-bit MOV instruction of pulse execution type)



Entering coils using Reference command:

Click the Reference command. The following dialog box will appear on the display. Using this dialog box, you can select instructions from the list, or look up the functions of operands.

You can select an instruction from the list to enter an instruction in this box. In addition, you can directly enter an instruction or FNC number in this box.
Example: ZCP, DZCP, FNC11, FNC11P

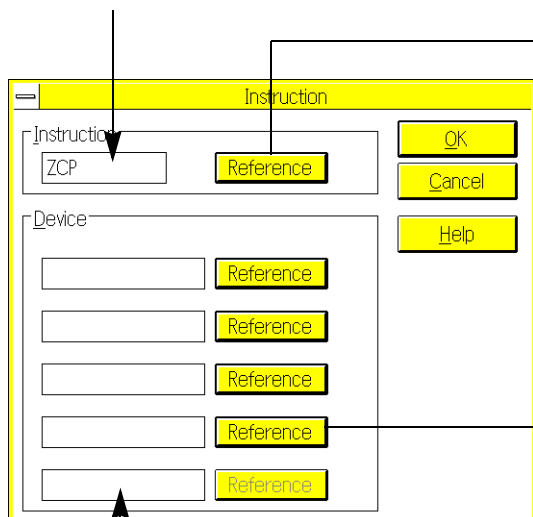

Describes the operand necessary for each instruction type. The system enters the data entry waiting status.

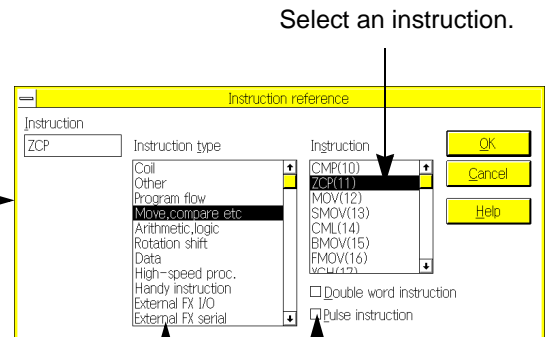

Select an instruction.
Shows the instruction types. Click this button to use the instruction as the 32-bit type or pulse execution type.

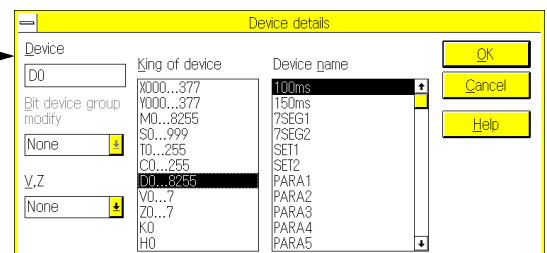

You can specify operands, or enter device names.

5.3.4 Wire

OPN	L/V	L/M	I/V	S/V	S/M
	✓				
—	C/V	R/V	D/L	D/M	SMP

Use this command to enter vertical and horizontal lines and INV instruction, or delete vertical lines.

Note that this command has the same function as function keys **⇧Shift** + **F9** (|), **F9** (-), **⇧Shift** + **F7** (-/-), and **⇧Shift** + **F8** (| DEL).

SWOPC-FXGP/WIN-E
Tools Search View

- Contact
- Coil
- Function
- Wire**
 - |
 -
 - /-
 - | DEL
- All clear...
- Convert

Click this command to enter a vertical line.
Click this command to enter a horizontal line.
Click this command to enter an INV command.
Click this command to delete a vertical line.

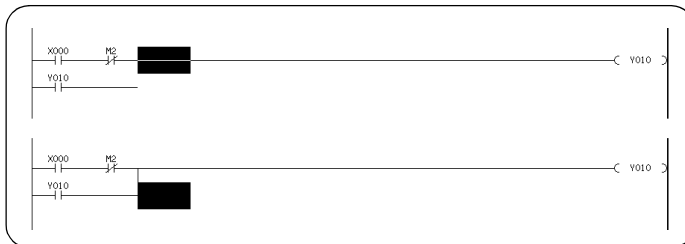

Entering vertical line

A vertical line will be entered at the lower left section of the cursor.

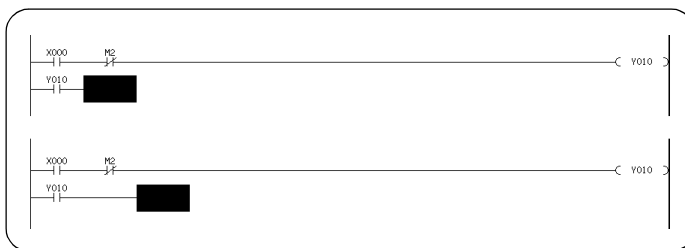

Entering horizontal line

A horizontal line will be entered at the cursor position.

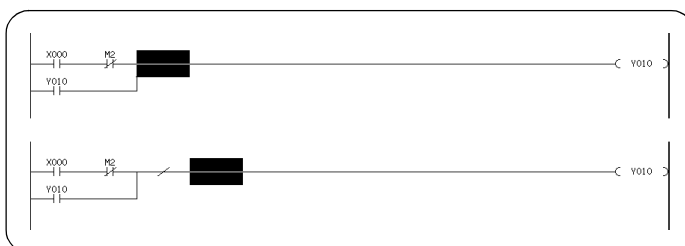

Entering INV instruction

An INV instruction will be entered at the cursor position.

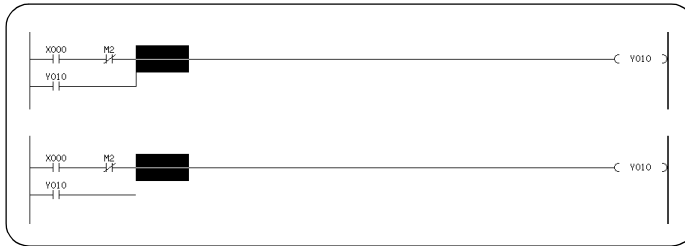

Deleting vertical line

A vertical line will be deleted from the lower left section of the cursor.

5.3.5 Instruction

OPN	L/V	L/M	I/V	S/V	S/M
			✓		
—	C/V	R/V	D/L	D/M	SMP

On the list edit screen, you can directly enter instructions and device numbers using the keyboard. By the way, if you use the Instruction command, you can edit programs using lists or references displayed in the dialog box.

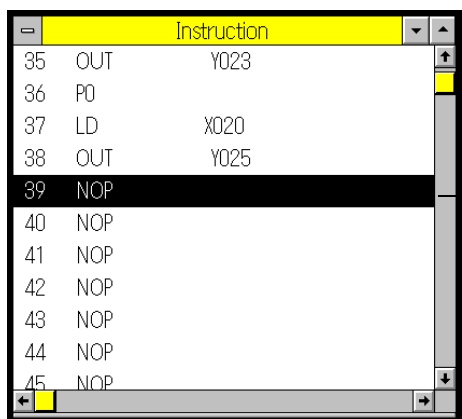

You can select an instruction from the list to enter an instruction in this box. In addition, you can directly enter an instruction or FNC number in this box.
 Example: LD, AND, OUT, ZCP, DZCP, FNC11, FNCD11P

Shows the instruction types.

Select an instruction.

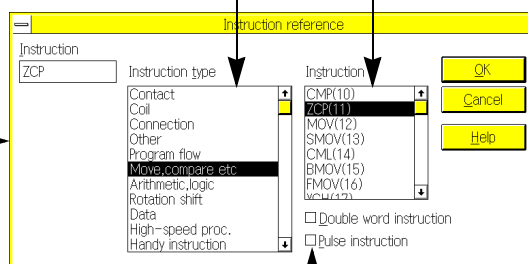

Click this button to use the instruction as the 32-bit type or pulse execution type.

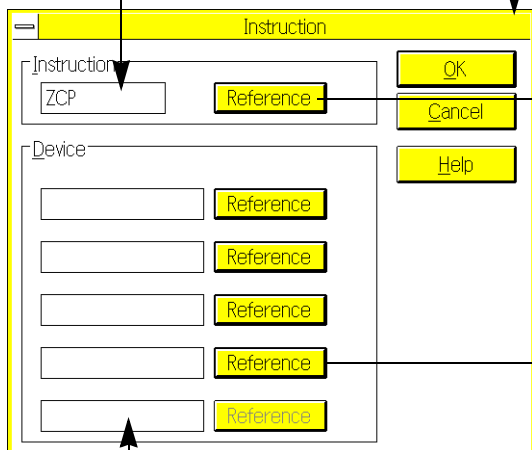

Describes the operand necessary for each instruction type. The system enters the data entry waiting status.

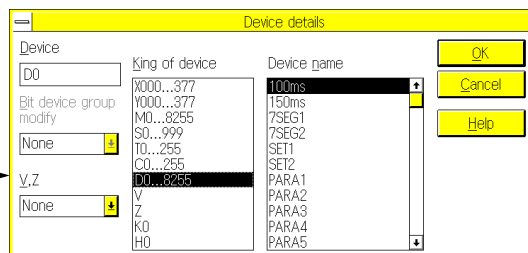

You can specify operands, or enter device names.

5.3.6 All Clear

OPN	L/V	L/M	I/V	S/V	S/M
	✓		✓		
—	C/V	R/V	D/L	D/M	SMP
	✓	✓		✓	

Use this command to clear the active work window.

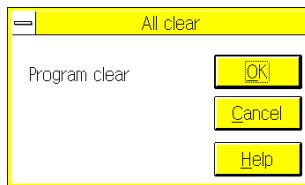

Clearing program area

Applicable windows:

- Ladder diagram edit window
- List edit window

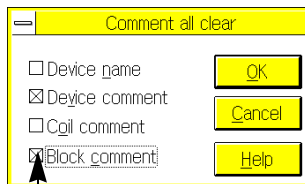

Specify the item to be erased by clicking the button.

Clearing comment area

Applicable windows:

- Device name comment window
- Device comment window

To erase coil comments and block comments, open the device name comment window or device comment window.

Note that the set comment data to be written in the programmable controller will be erased also.

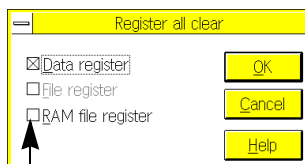

Specify the item to be erased by clicking the button.

Clearing register area

Applicable windows:

- Register window
- When data registers are displayed
- When file registers are displayed
- When RAM registers are displayed

5.3.7 Convert

OPN	L/V	L/M	I/V	S/V	S/M
	✓			✓	
—	C/V	R/V	D/L	D/M	SMP

Use this command to convert the ladder or SFC diagram program data into instruction list.

Note that this command has the same function as function key **F4** (Convert).

- If a ladder or SFC diagram created on the screen is not converted, it is only a diagram, therefore it is not valid.
To make the diagram valid, the diagram should be converted into a sequence program (instruction list). If you use the list edit function for programming, conversion will not be needed. This is because in the list edit mode, you have to directly create an instruction list by directly entering instructions.
- Convert the diagram when:
 - 1) You check the created data of the ladder or SFC diagram.
 - 2) You edit a list after creating the ladder or SFC diagram.(Convert the diagram into instruction list, and then edit the list.)
 - 3) You close the ladder or SFC diagram edit window.(When you minimize the window, conversion will not be needed.)
 - 4) You end the FXGP/WIN-E by executing Close or Exit.
 - 5) You turn off the power of the computer.
- Be careful! The non-converted ladder or SFC diagram may be erased if you make an operation error.
- When "Convert and run time program changes" is selected by "Option → Preferences", "Run time program changes" is executed also after "CNV F4" or "Tools → convert" is executed.



Conversion of ladder or SFC diagram into instruction list:

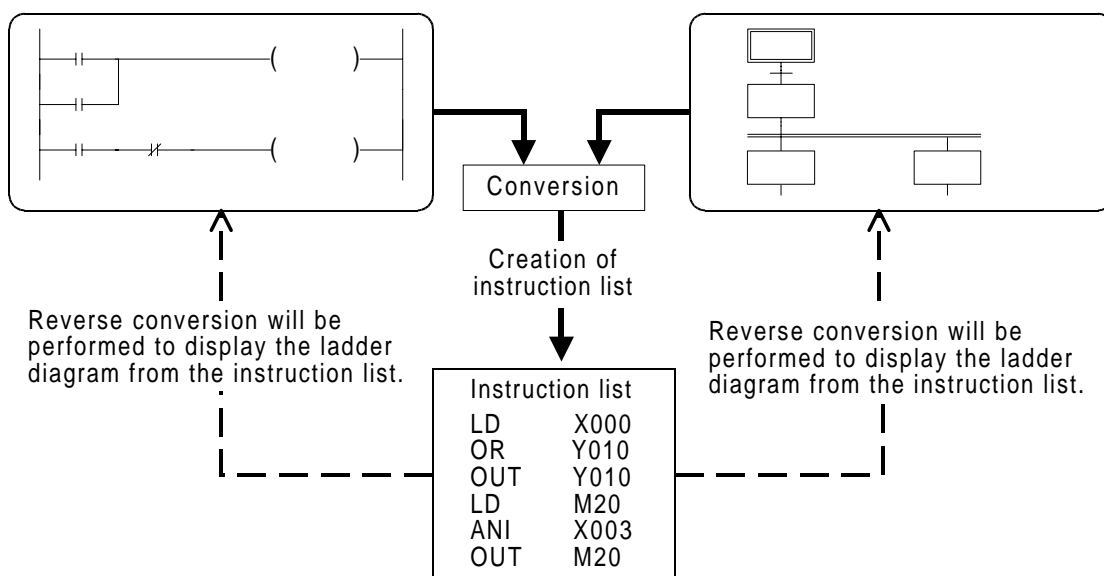

5.3.8 Default comments for special M/D

	OPN	L/V	L/M	I/V	S/V	S/M
—		C/V	R/V	D/L	D/M	SMP
		✓				

Use this command to store default comments in the special auxiliary relay comment area (M8000 and subsequent numbers) or special data register comment area (D8000 and subsequent numbers) using the device comment/name window.

If device comments are already stored in the specified area, executing this command will overwrite the default comments, therefore the device comments previously stored will be erased.

Specify the comments you want to store.

Example: Comments stored in special auxiliary relay comment area

Device	Device comment	Name
M8000	RUN monitor NO contact	
M8001	RUN monitor NC contact	
M8002	Initial pulse NO contact	
M8003	Initial pulse NC contact	
M8004	Error occurrence	
M8005	Low battery voltage	
M8006	Low battery voltage latch	
M8007	Momentary power failure detected	
M8008	Power failure	
M8009	24V DC OFF	
M8010		
M8011	10 msec clock	
M8012	100 msec clock	
M8013	1 sec clock	
M8014	1 min clock	
M8015	Inner clock	
M8016	Inner clock	
M8017	Inner clock	
M8018	Inner clock	

5.3.9 Setting of comment moved to PLC

OPN	L/V	L/M	I/V	S/V	S/M
—	C/V	R/V	D/L	D/M	SMP
	✓				

Use this command in the device comment/name window to specify the device comments to be written in the programmable controller.

Sets the specified device comments as the comments to be written in the programmable controller.

After pressing this button, an asterisk * will appear next to the specified device numbers.

Resets the specified device comments. This means that the specified device comments will be regarded as the comments not be written in the programmable controller.

- To write the device comments in the programmable controller, 1 block or more of comment area should be secured. To secure the comment area, click Option and then Parameter Settings.
- Enter the same type of device in the From and To boxes. To specify two or more types of devices, such as input relay (X) and output relay (Y), specify the devices for each type of device.
- If the same device number is entered in the From and To boxes, only one device comment will be set as the comment to be transferred to the programmable controller.
- To specify non-continuous device numbers, execute this command repeatedly. Or in the device comment/name window, click the right button of the mouse on each device.
- Even if you specify a device that has no device comment, the number of set device comments will be increased, and the free storage area will be reduced for the device comments. For this reason, do not specify any unnecessary devices.

Operation in device comment / device name window:

To specify device comments to be written in the program area of the programmable controller, click Tools and then Setting of Comment Move to programmable controller. Or in the device comment/name window, click the right button of the mouse at the cursor position or after specifying the range.

After specifying the device comments to be written in the programmable controller, an asterisk * will appear next to the corresponding device numbers.

When comments are transferred from the program area (where comments read out from the programmable controller or file are stored) to the device comment area, an asterisk * will appear next to the corresponding device numbers also (see Sec. 5.1.2 and Sec. 5.6.1).

Device	Device comment	Name
Y000*	LAMP No.1	LAMP1
Y001*	LAMP No.2	LAMP2
Y002*	LAMP No.3	LAMP3
Y003*	Ry1	NGLAMP
Y004*	Ry2	OK.LAMP
Y005*	Ry3	TEST
Y006*	Ry(POWER)	RY1
Y007*	ERROR.No.1	RY2
Y010*	ERROR.No.2	RY3
Y011*	ERROR.No.3	BUZZER
Y012*	MC1	LED1
Y013*	MC2	LED2
Y014*	MC3	LED.Y
Y015*	MC4	LED.R
Y016		LED.B
Y017		LED.G
Y020		
Y021		
Y022		
Y023		
Y024		

Comment | Device comment (14 / 50) | FX2N / FX2NC

Indicates the device comment storage capacity.
(Unit: comments)

Indicates the number of set device comments that is to be written in the programmable controller. (Unit: comments)

5.3.10 Setting of step of comment

OPN	L/V	L/M	I/V	S/V	S/M
—	C/V	R/V	D/L	D/M	SMP
	✓				

Use this command to correct the comment step indication in the block comment window or coil comment window (see Sec. 5.5.5).

After adding or deleting a sequence program, the comment step numbers will be automatically adjusted, but the brackets showing the block/coil comment steps will not move automatically together with the step numbers.

For this reason, to enter comments in the block comment window or coil comment window after changing a sequence program, be sure to execute this command to correct the bracket positions.

MEMO

5.4 Search Menu Functions

The command functions of the Search menu can be classified into the following types.

- (1) Commands used for jumping to another place in the work window, such as Go to Top and Go to end and Tag jump
- (2) Commands used for searching comment character strings
- (3) Commands used for searching programs using device names, device numbers, and instruction symbols
- (4) Commands used for replacing character strings and device numbers
- (5) Commands used for inverting contact logic or device numbers



Relation between convert and search

Before using a search command in the ladder or SFC diagram editing status, be sure to convert the diagram.

If the ladder or SFC diagram is not converted, the diagram will not be valid as the sequence program. For this reason, if you click a search command, a message will appear on the display to request conversion.

5.4.1 Go to Top, Go to End

OPN	L/V	L/M	I/V	S/V	S/M
	✓	✓	✓	✓	✓
—	C/V	R/V	D/L	D/M	SMP
	✓	✓			

Use this command to move the cursor to the top or end of the document.

Example: Going to top or end of ladder diagram

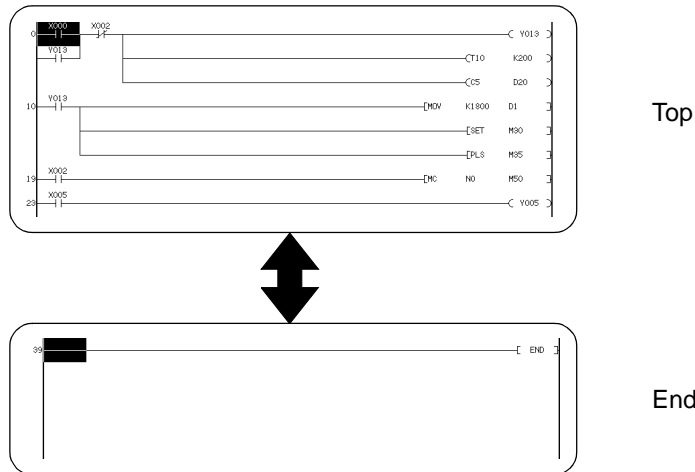

Example: Going to top or end of instruction list

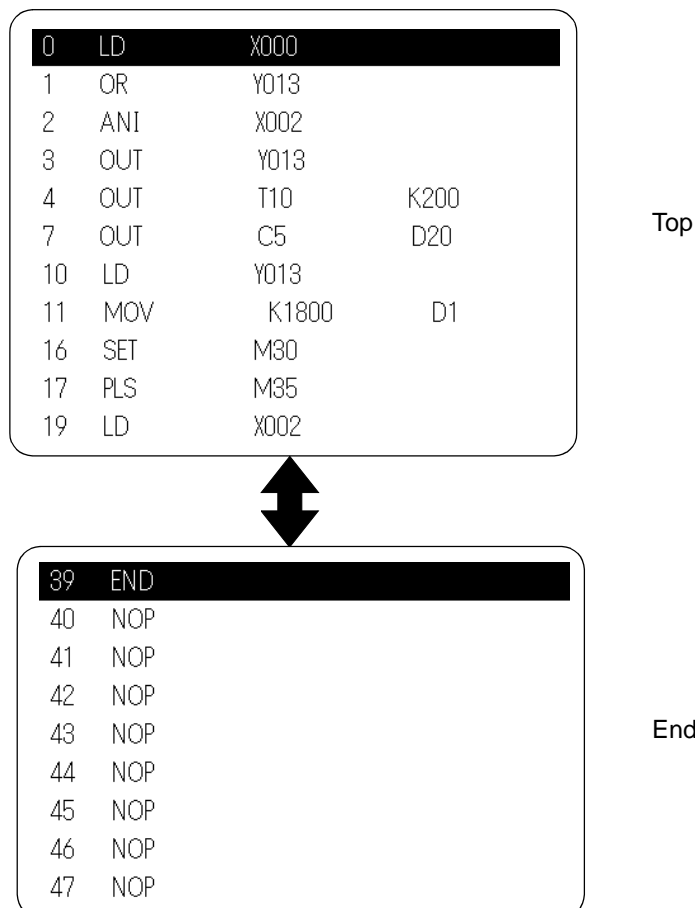

5.4.2 Device Name Search

OPN	L/V	L/M	I/V	S/V	S/M
	✓	✓	✓	✓	✓
—	C/V	R/V	D/L	D/M	SMP

Use this command to search the specified device name in the program.

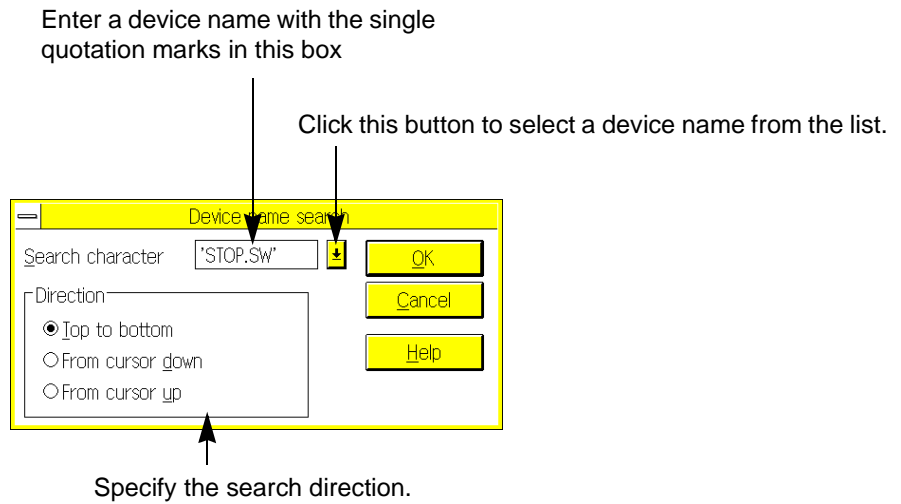

- Even if device names are not displayed on the screen, the corresponding device number will be searched.

5.4.3 Device Search

OPN	L/V	L/M	I/V	S/V	S/M
	✓	✓	✓		
—	C/V	R/V	D/L	D/M	SMP

Use this command to search the specified device number in the program.

Enter the device number.
 Applicable devices: X, Y, M, S, T, C, D, V, Z, P, and I

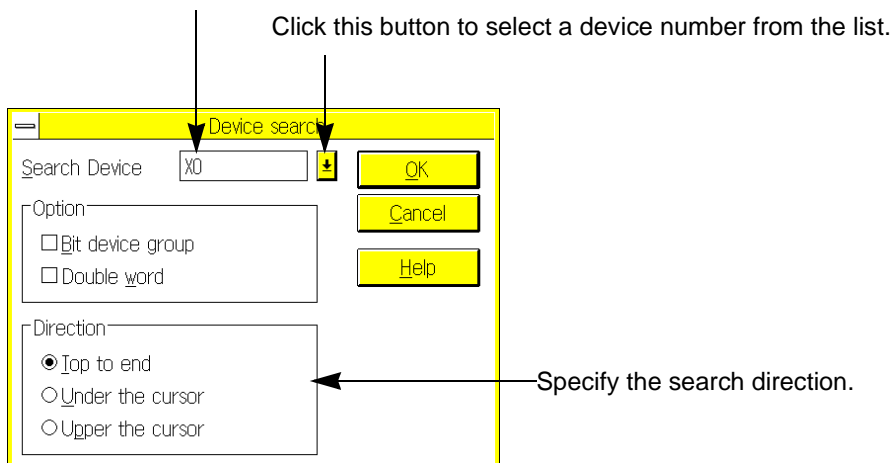

Even if the device numbers are not displayed on the screen (but device names are displayed), the device corresponding to the set device number will be searched.

5.4.4 Instruction Search

OPN	L/V	L/M	I/V	S/V	S/M
	✓	✓	✓		
—	C/V	R/V	D/L	D/M	SMP

Use this command to search the specified instruction symbol.

Enter an instruction in this box.
 Example: LD, AND, OUT, SET, MOV, DMOV, FNC12, FNCD12P, etc.

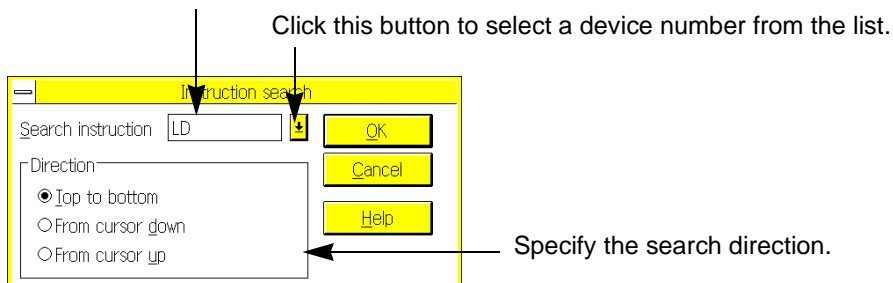

To search the program by specifying an instruction and device number, use the Contact/ Coil Search command as described on the next page.

5.4.5 Contact/Coil Search

OPN	L/V	L/M	I/V	S/V	S/M
	✓	✓	✓		
—	C/V	R/V	D/L	D/M	SMP

Use this command to search the program for the specified contact symbol and device number.

Click this button to select a contact symbol from the list.

-I I- , -I/ I- , -IPI- , -IFI- , -()- , - [] -

5.4.6 Go to Step

OPN	L/V	L/M	I/V	S/V	S/M
	✓	✓	✓		
—	C/V	R/V	D/L	D/M	SMP

Use this command to go to the specified program step.

5.4.7 Go to State

OPN	L/V	L/M	I/V	S/V	S/M
				✓	✓
—	C/V	R/V	D/L	D/M	SMP

Use this command to go to the specified state in the SFC diagram edit window.

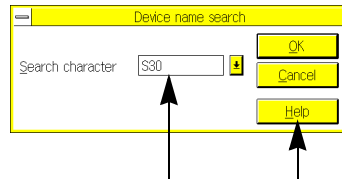

Enter the state number in this box. Click this button to select a state number from the list.

5.4.8 Character Search

OPN	L/V	L/M	I/V	S/V	S/M
—	C/V	R/V	D/L	D/M	SMP
	✓				

Use this command to search the specified character string.

Enter a character string.

Click this button to recognize capital letters and small letters as different characters in search operation.

Specify the search direction.

5.4.9 Character Exchange

OPN	L/V	L/M	I/V	S/V	S/M
—	C/V	R/V	D/L	D/M	SMP
	✓				

Use this command to find and replace the specified character string.

Enter the character string you want to find.

Click this button to recognize capital letters and small letters as different characters in search operation.

Enter the character string to be replaced with the above character string.

Click the Select button to sequentially find and replace the character strings. The dialog box will appear each time, and ask if you want to replace the character string. Click the Replace All button to replace all the character strings at a time.

5.4.10 Change Device Number

OPN	L/V	L/M	I/V	S/V	S/M
	✓		✓	✓	
—	C/V	R/V	D/L	D/M	SMP

Use this command to replace the specified device numbers to other numbers.

Applicable devices: X, Y, M, S, T, C, and D

Enter the same type of devices in the Find What and Replace With boxes.
 Examples: X→X, Y→Y, M→M, T→T, D→D, etc.

Click the Select button to sequentially find and replace the devices. The dialog box will appear each time, and ask if you want to replace the device. Click the Replace All button to replace all the devices at a time.

Click the desired button to determine how to process the device numbers included in the application instructions.

Click the desired button to determine how to process the device comments corresponding to the specified device numbers.

Example of replacement: M0→M200 M5→M205
 M1→M201 M6→M206
 M2→M202 M7→M207
 M3→M203 M8→M208
 M4→M204 M9→M209



Devices cannot be replaced if the number of steps differ from each other.

- 1) M0 to M1535 ↔ M1536 to M3071 (For FX_{2N} programmable controller only)
- 2) 16-bit counter ↔ 32-bit counter (Common to FX programmable controller)

5.4.11 Change Bit Device

OPN	L/V	L/M	I/V	S/V	S/M
	✓		✓	✓	
—	C/V	R/V	D/L	D/M	SMP

Use this command to invert the logic of the contact instructions for the specified device numbers.
 Applicable devices: X, Y, M, S, T, and C

Click the Select button to sequentially find and replace the devices.

The dialog box will appear each time, and ask if you want to replace the device.

Click the Replace All button to replace all the devices at a time.

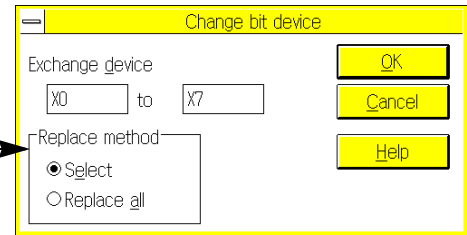

Change pattern:

	→		LD	→	LDI
	→		LDI	→	LD
	→		AND	→	ANI
	→		ANI	→	AND
	→		OR	→	ORI
	→		ORI	→	OR

5.4.12 Swap Device Number

OPN	L/V	L/M	I/V	S/V	S/M
	✓		✓	✓	
—	C/V	R/V	D/L	D/M	SMP

Use this command to replace the specified device numbers with each other.
 Applicable devices: X, Y, M, S, T, C, and D

Click the Select button to sequentially find and replace the devices. The dialog box will appear each time, and ask if you want to replace the device.

Click the Replace All button to replace all the devices at a time. The device numbers included in the application instructions will be also replaced.

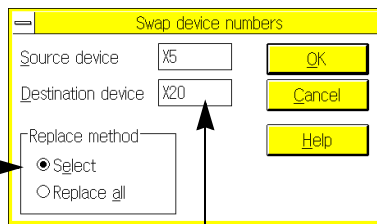

Example of replacement

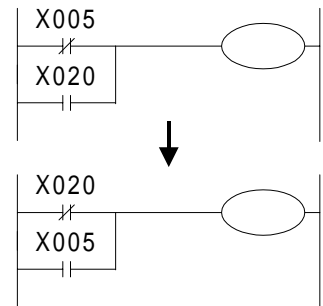

Enter the same type of devices in these boxes to ensure device replacement to the same type.

Examples:

X↔X, Y↔Y, M↔M, T↔T, D↔D, etc.



Devices cannot be replaced if the number of steps differ from each other.

- 1) M0 to M1535 ↔ M1536 to M3071 (For FX_{2N} programmable controller only)
- 2) 16-bit counter ↔ 32-bit counter (Common to FX programmable controller)

5.4.13 Tag Set

OPN	L/V	L/M	I/V	S/V	S/M
	✓	✓	✓	✓	
—	C/V	R/V	D/L	D/M	SMP

Use this command to set the tag used for Tag Jump. In the ladder diagram edit window, the first step number in the cursor-positioned circuit block will be stored as the tag. In the list edit window, the cursor-positioned step number will be stored as the tag.

Stores step 75 as the tag.

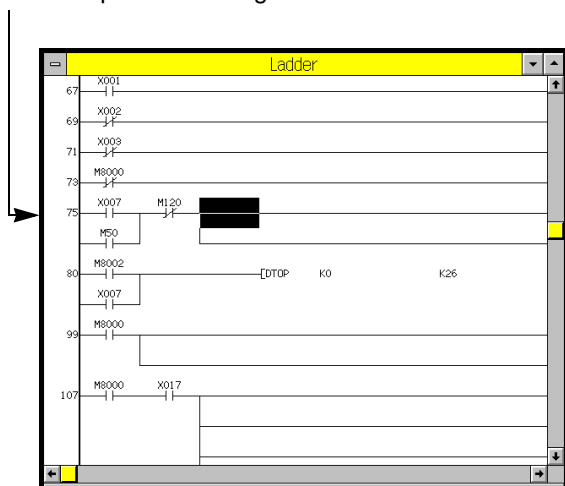

Stores step 74 as the tag.

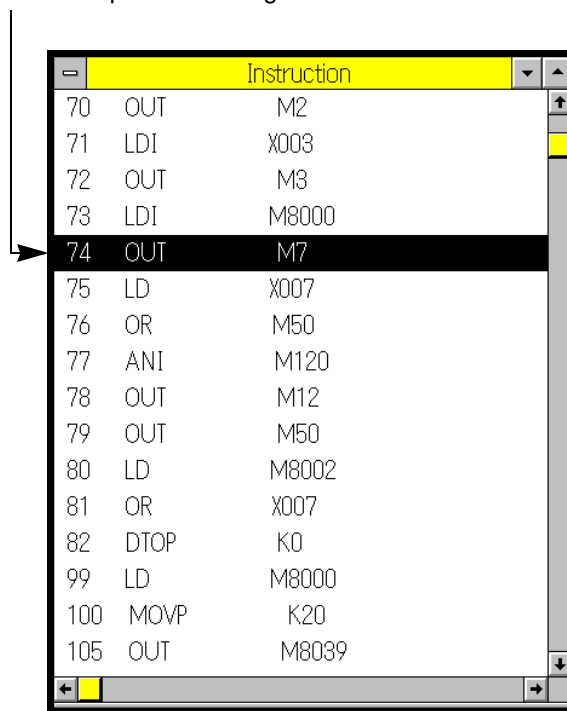

5.4.14 Tag Jump

OPN	L/V	L/M	I/V	S/V	S/M
	✓	✓	✓	✓	
—	C/V	R/V	D/L	D/M	SMP

Use this command to jump to the tag position.

Select a tag from the list. Up to 10 tags can be stored in the list. If you store the eleventh tag, the oldest tag will be deleted.

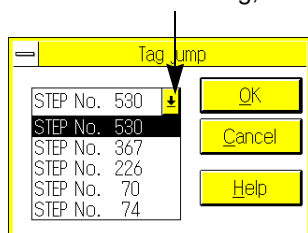

MEMO

5.5 View Menu Functions

The commands on the View menu enables you to switch the work windows or display the selected items. Switching windows is an important operation of the FXGP/WIN-E.

Windows that can be switched by View menu commands

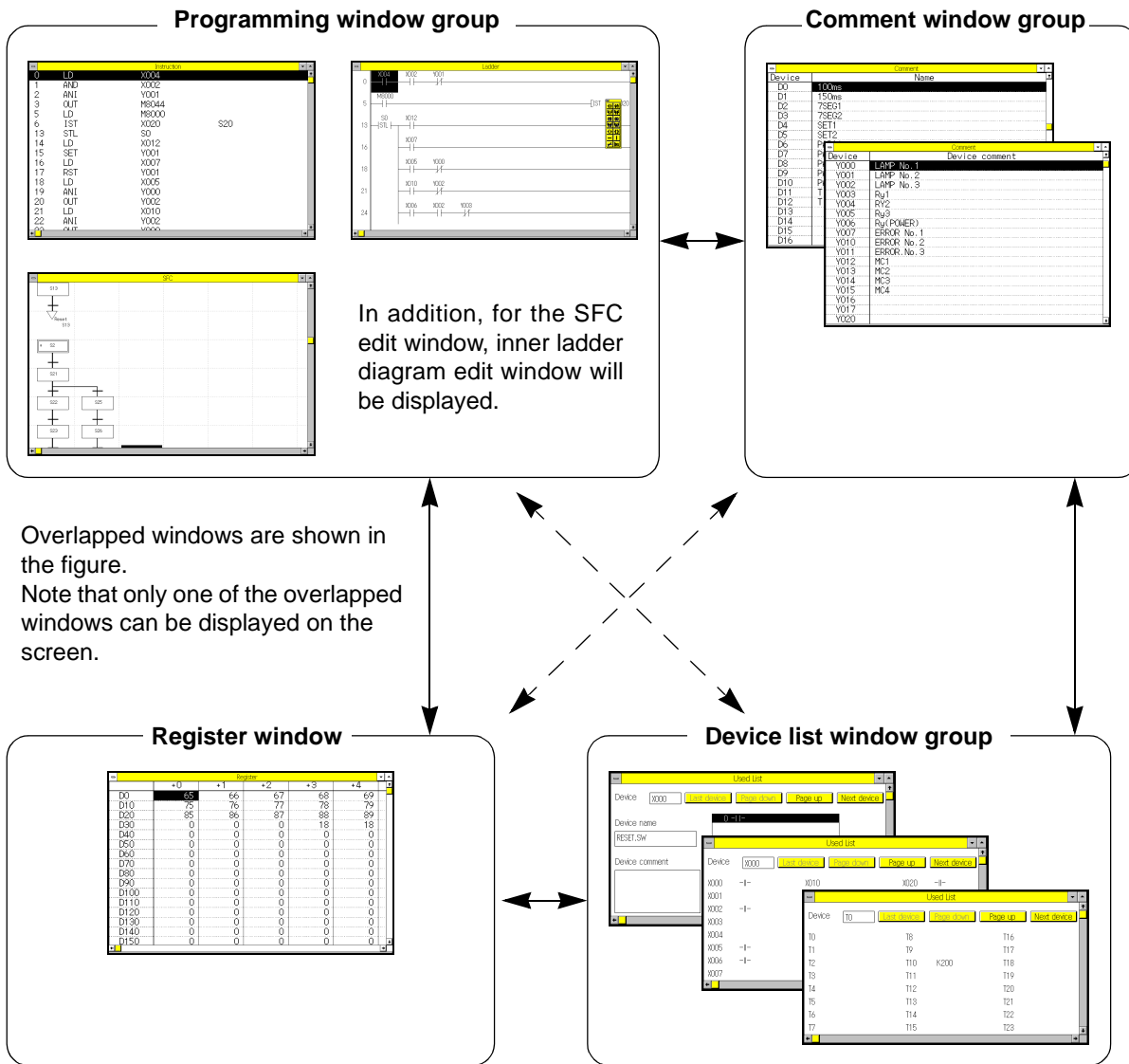

5.5.1 Ladder View

OPN	L/V	L/M	I/V	S/V	S/M
	✓		✓	✓	
—	C/V	R/V	D/L	D/M	SMP
	✓	✓	✓	✓	✓

Use this command to display the ladder diagram edit window.

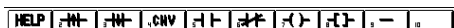
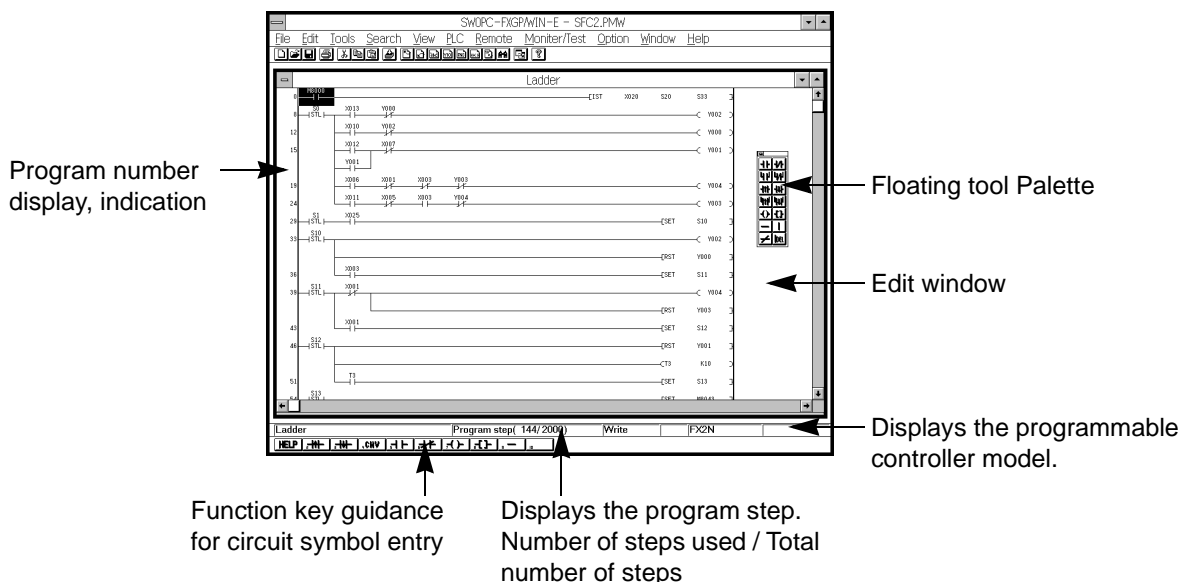

Press the Shift key to display the sub-guidance.



Functions of ladder diagram edit window:

1. Displaying and editing existing sequence programs (see Sec.6.2.4)
2. Creating new sequence circuits and editing them (see Sec.6.2.4)
3. Storing and displaying comments (see Sec.5.2.12, 5.2.15, and 5.5.12)
4. Displaying ladder diagrams so that operator can monitor operation of programmable controller (see Sec.5.7.1)
5. Writing program in run mode (see Sec.5.6.1)
6. Printing ladder diagrams (see Sec.5.1.6 and 5.1.7)

5.5.2 Instruction View

OPN	L/V	L/M	I/V	S/V	S/M
	✓		✓	✓	
—	C/V	R/V	D/L	D/M	SMP
	✓	✓	✓	✓	✓

Use this command to display the instruction list edit window.

Displays the instructions.

Displays the device numbers and application instruction operands.

Program number display, indication

Edit window

Displays the programmable controller model.

Function key guidance for instruction entry

Displays the program step. Number of steps used / Total number of steps



Press the Shift key to display the sub-guidance.

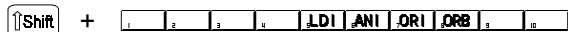

Functions of list edit window:

1. Displaying and editing existing sequence programs (see Sec.6.3.2)
2. Creating new sequence instruction lists and editing them (see Sec.6.3.2)
3. Displaying comments (see Sec.5.5.12)
4. Printing instruction lists (see Sec.5.1.6 and 5.1.7)

5.5.3 SFC View

OPN	L/V	L/M	I/V	S/V	S/M
	✓		✓	✓	
—	C/V	R/V	D/L	D/M	SMP
	✓	✓	✓	✓	✓

Use this command to display the SFC diagram edit window. Inner ladder diagram edit windows for ladder blocks, states, transitions, can be also displayed.

SFC diagram

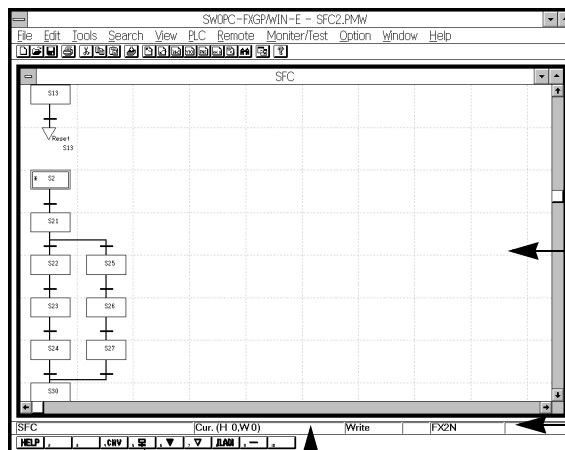

← Edit window

← Displays the programmable controller model.

Function key guidance: Use this guidance to enter SFC symbols.

Displays the coordinates of the cursor position.



Press the Shift key to display the sub-guidance.



Functions of SFC diagram edit window:

1. Displaying and editing SFC diagrams of the existing sequence programs (see Sec.7.2.4)
2. Creating new SFC diagrams and editing them (see Sec.7.2.4)
3. Displaying, creating, and editing inner ladder diagrams (see Sec.7.2.3 and 5.5.4)
4. Displaying comments (see Sec.5.5.12)
5. Displaying SFC diagrams so that operator can monitor operation of programmable controller (see Sec.5.7.2 and 5.7.3)
6. Printing SFC diagrams (see Sec.5.1.6 and 5.1.7)

5.5.4 Inner Ladder View

OPN	L/V	L/M	I/V	S/V	S/M
				✓	
—	C/V	R/V	D/L	D/M	SMP

Use this command to display the inner ladder diagram edit windows. In this window, inner ladder diagrams of ladder blocks, states, transitions can be displayed.

Position the cursor on a SFC symbol in the SFC diagram edit window, and then execute View and then Inner Ladder View.

For a detailed description of inner ladder diagrams, refer to Sec.7.2.3 "Creating SFC diagrams" and Sec.6.2 "Creating Ladder Diagrams".

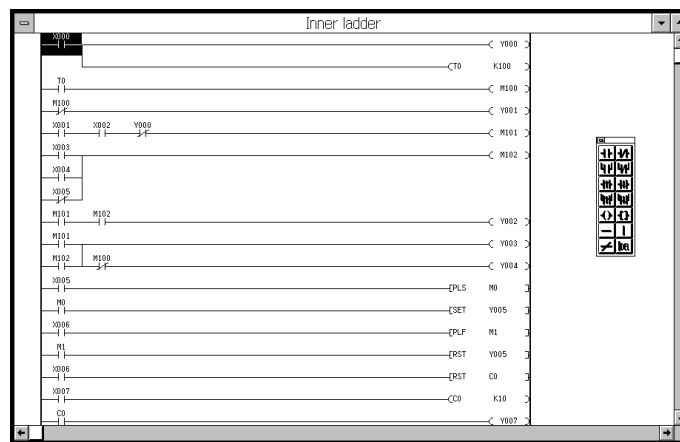

Execute View and then Inner Ladder View to display the inner ladder diagram of the cursor positioned symbol.

5.5.5 Comment View

OPN	L/V	L/M	I/V	S/V	S/M
	✓		✓	✓	
—	C/V	R/V	D/L	D/M	SMP
	✓	✓	✓	✓	✓

Use this command to display the device name or device comment edit window. Using these windows, you can store and edit the device names and device comments.



Saving and reading comment files exclusively

A comment file exclusively can be saved with a different name. An existing comment file can be read into the program file currently created.

In the state in which the comment window is selected, perform the following operation.

When saving a comment file: File → Export

When reading an existing comment file: File → Import

When a program is saved or read, a comment file is usually processed together. The export or import operation is required exclusively when a comment file is required to be processed independently. (See Sec.5-1-2, 5-1-4)

Device Comment / Device name

The list of Device comments / Device name will be displayed in the window. Using this window, you can store, edit, or print the Device comments / Device name. For a detailed description of Device comments / Device name, refer to Sec.5.2.12 and 5.2.13.

Enter the device number to be displayed first in the list.

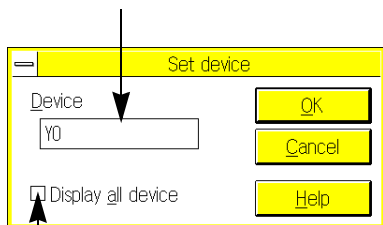

Click this button to display all the devices while ignoring the programmable controller model. The device numbers non-stored in the programmable controller will be displayed in red.

Double-click in the device number column to designate a number. The Designate Device dialog box shown above will appear on the display.

Device	Device comment	Name
Y000	LAMP No.1	LAMP1
Y001	LAMP No.2	LAMP2
Y002	LAMP No.3	LAMP3
Y003	Ry1	NG.LAMP
Y004	Ry2	OK.LAMP
Y005	Ry3	TEST
Y006	Ry(POWER)	RY1
Y007	ERROR No.1	RY2
Y010	ERROR No.2	RY3
Y011	ERROR No.3	BUZZER
Y012	MC1	LED1
Y013	MC2	LED2
Y014	MCS	LED.Y
Y015	MC4	LED.R
Y016		LED.B
Y017		LED.G
Y020		
Y021		
Y022		

Use the **↑Shift + ↓** / **↑** keys, or drag the mouse to specify the range.

Functions of Device comment / Device name edit window:

1. Displaying list of device comments already stored
2. Storing and editing device comments (In the ladder diagram edit window, click Edit and then Device Comments to individually store the device comments.)
3. Storing and editing device names (In the ladder diagram edit window, click Edit and then Device Name to individually store the device names.)
4. Printing device comments (see Sec.5.1.6 and 5.1.7)



Specifying comments to be written in programmable controller:

Device comments you specified can be stored in the parameter-set program area of the programmable controller (see Sec. 1.4, Sec. 5.2.13, and Sec. 5.3.9).

Block Comment

The list of block comments will be displayed in the block comment window. Using this window, you can store or edit the block comments. For a detailed description of block comments, refer to Sec.5.2.15.

Enter the device number to be displayed first in the list.

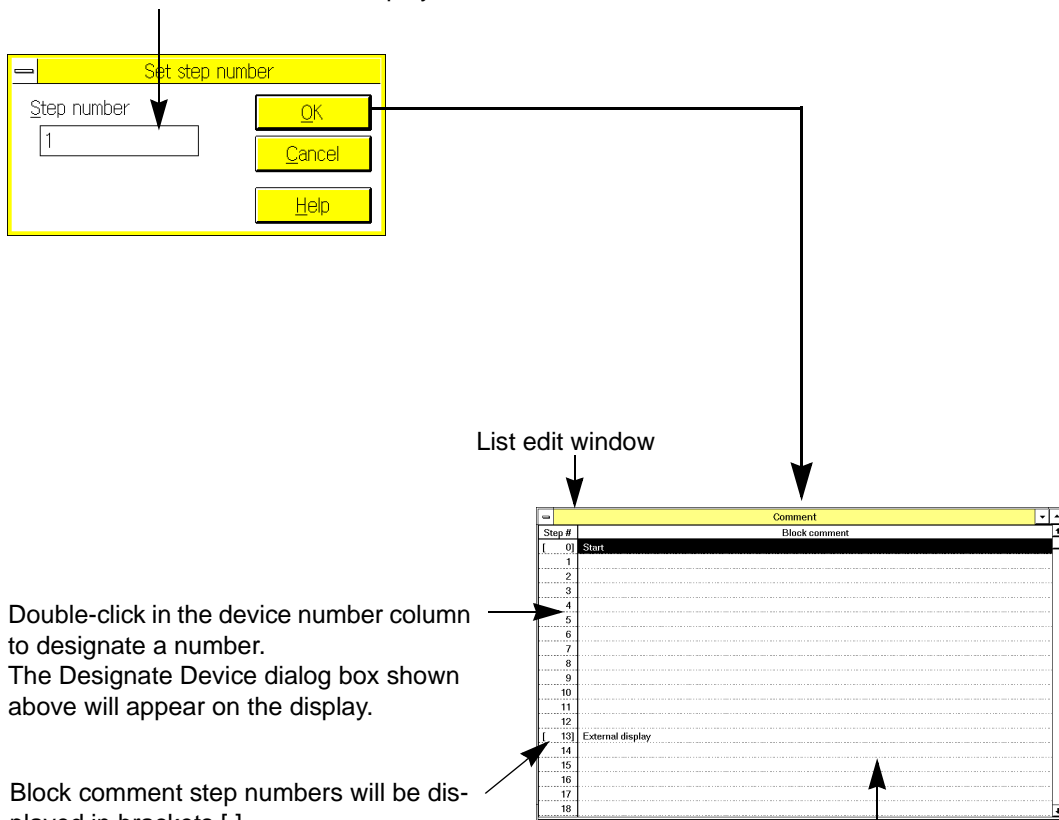

Double-click in the device number column to designate a number. The Designate Device dialog box shown above will appear on the display.

Block comment step numbers will be displayed in brackets [].

Use the **Shift** + **↓**/**↑** keys, or drag the mouse to specify the range.

The block comment storage positions are controlled by the first step numbers of the circuit blocks, therefore use the first step numbers to display or store the circuit comments. After inserting or deleting a program, the step numbers will be automatically corrected. The brackets [] of the block comment step numbers, however, will not move automatically. To correct the bracket positions, click Edit and then Setting of Step of Comment (see Sec. 5.3.10).

Functions of block comment edit window:

1. Displays the list of block comments already stored.
2. Stores and edits block comments. (If you use the ladder diagram edit window, you can individually store each block comment by clicking Edit and then Block Comment.)

Coil Comment

The list of coil comments will be displayed in the coil comment window. Using this window, you can store or edit the coil comments. For a detailed description of coil comments, refer to Sec.5.2.14.

Enter the device number to be displayed first in the list.

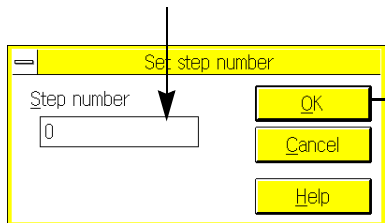

List edit window

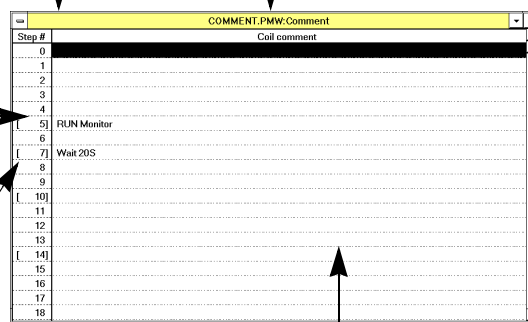

Double-click in the device number column to designate a number. The Designate Device dialog box shown above will appear on the display.

The step No. which is the target of a coil comment is displayed inside []

Use the **Shift + ↑ / ↓** keys, or drag the mouse to specify the range.

The coil comment storage positions are controlled by the step numbers of the output control instructions, therefore use the step numbers of the instructions to display or store the coil comments. After inserting or deleting a program, the step numbers will be automatically corrected. The brackets [] of the block comment step numbers, however, will not move automatically. To correct the bracket positions, click Edit and then Setting of Step of Comment (see Sec. 5.3.10).

Functions of coil comment edit window:

1. Displays the list of coil comments already stored.
2. Stores and edits coil comments. (If you use the ladder diagram edit window, you can individually store each coil comment by clicking Edit and then Coil Comment.)

5.5.6 Register View

OPN	L/V	L/M	I/V	S/V	S/M
	✓		✓	✓	
—	C/V	R/V	D/L	D/M	SMP
	✓	✓	✓	✓	✓

Use this command to display the register edit window.

Enter the register number to be displayed first in the window.

Select the display type.

Select the numeric value display mode.

Click this button to display all the devices while ignoring the programmable controller model. The device numbers non-stored in the programmable controller will be displayed in red.

Select 32 bit to display and edit the data of the 32-bit register.

To display 32-bit data, select Even Numbers or Odd Numbers. The 16-bit register device numbers of the selected type (even or odd numbers) will be determined as the low-order side. If the selected low-order side differs from that specified in the program, wrong values will be displayed on the screen.

Functions of register edit window:

1. Displaying and editing data register data or file register data read out from programmable controller
2. Creating and editing data register data or file register data to be written into programmable controller

Example: 16bit Register view

Binary data, table type

Register										
	+0	+1	+2	+3	+4					
D0	00000000	01000001	00000000	01000010	00000000	01000011	00000000	01000100	00000000	01000101
D10	00000000	01001011	00000000	01001100	00000000	01001101	00000000	01001110	00000000	01001111
D20	00000000	01010101	00000000	01010110	00000000	01010111	00000000	01011000	00000000	01011001
D30	00000000	00000000	00000000	00000000	00000000	00000000	00000000	00010010	00000000	00010010
D40	00000000	00000000	00000000	00000000	00000000	00000000	00000000	00000000	00000000	00000000
D50	00000000	00000000	00000000	00000000	00000000	00000000	00000000	00000000	00000000	00000000
D60	00000000	00000000	00000000	00000000	00000000	00000000	00000000	00000000	00000000	00000000
D70	00000000	00000000	00000000	00000000	00000000	00000000	00000000	00000000	00000000	00000000
D80	00000000	00000000	00000000	00000000	00000000	00000000	00000000	00000000	00000000	00000000
D90	00000000	00000000	00000000	00000000	00000000	00000000	00000000	00000000	00000000	00000000
D100	00000000	00000000	00000000	00000000	00000000	00000000	00000000	00000000	00000000	00000000
D110	00000000	00000000	00000000	00000000	00000000	00000000	00000000	00000000	00000000	00000000
D120	00000000	00000000	00000000	00000000	00000000	00000000	00000000	00000000	00000000	00000000
D130	00000000	00000000	00000000	00000000	00000000	00000000	00000000	00000000	00000000	00000000
D140	00000000	00000000	00000000	00000000	00000000	00000000	00000000	00000000	00000000	00000000

You can edit the numeric values of the data cell.

Double-click the device number column. The display setting dialog box will appear on the display.

Decimal data, table type

Register										
	+0	+1	+2	+3	+4	+5	+6	+7	+8	+9
D0	65	66	67	68	69	70	71	72	73	74
D10	75	76	77	78	79	80	81	82	83	84
D20	85	86	87	88	89	90	28	896	0	0
D30	0	0	0	18	18	210	425	1126	0	0
D40	0	0	0	0	0	0	0	0	0	0
D50	0	0	0	0	0	0	0	0	0	0
D60	0	0	0	0	0	0	0	0	0	0
D70	0	0	0	0	0	0	0	0	0	0
D80	0	0	0	0	0	0	0	0	0	0
D90	0	0	0	0	0	0	0	0	0	0
D100	0	0	0	0	0	0	0	0	0	0
D110	0	0	0	0	0	0	0	0	0	0
D120	0	0	0	0	0	0	0	0	0	0
D130	0	0	0	0	0	0	0	0	0	0
D140	0	0	0	0	0	0	0	0	0	0

Hexadecimal data, table type

Register										
	+0	+1	+2	+3	+4	+5	+6	+7	+8	+9
D0	41	42	43	44	45	46	47	48	49	4A
D10	4B	4C	4D	4E	4F	50	51	52	53	54
D20	55	56	57	58	59	5A	17	382	0	0
D30	0	0	0	12	12	02	169	466	0	0
D40	0	0	0	0	0	0	0	0	0	0
D50	0	0	0	0	0	0	0	0	0	0
D60	0	0	0	0	0	0	0	0	0	0
D70	0	0	0	0	0	0	0	0	0	0
D80	0	0	0	0	0	0	0	0	0	0
D90	0	0	0	0	0	0	0	0	0	0
D100	0	0	0	0	0	0	0	0	0	0
D110	0	0	0	0	0	0	0	0	0	0
D120	0	0	0	0	0	0	0	0	0	0
D130	0	0	0	0	0	0	0	0	0	0
D140	0	0	0	0	0	0	0	0	0	0

ASCII data, table type

Register										
	+0	+1	+2	+3	+4	+5	+6	+7	+8	+9
D0	A	B	C	D	E	F	G	H	I	J
D10	K	L	M	N	O	P	Q	R	S	T
D20	U	V	W	X	Y	Z	.	,		
D30										
D40										
D50										
D60										
D70										
D80										
D90										
D100										
D110										
D120										
D130										
D140										

Line type

Register				
	DEC	HEX	ASCII	BIN
D0	65	41	A	00000000 01000001
D1	66	42	B	00000000 01000010
D2	67	43	C	00000000 01000011
D3	68	44	D	00000000 01000100
D4	69	45	E	00000000 01000101
D5	70	46	F	00000000 01000110
D6	71	47	G	00000000 01000111
D7	72	48	H	00000000 01001000
D8	73	49	I	00000000 01001001
D9	74	4A	J	00000000 01001010
D10	75	4B	K	00000000 01001011
D11	76	4C	L	00000000 01001100
D12	77	4D	M	00000000 01001101
D13	78	4E	N	00000000 01001110
D14	79	4F	O	00000000 01001111
D15	80	50	P	00000000 01010000
D16	81	51	Q	00000000 01010001
D17	82	52	R	00000000 01010010
D18	83	53	S	00000000 01010011
D19	84	54	T	00000000 01010100
D20	85	55	U	00000000 01010101
D21	86	56	V	00000000 01010110
D22	87	57	W	00000000 01010111

Example: 32bit Register view

Binary data, table type

Register				
	+0	+2	+4	
D0	00000000	01000010	00000000	01000001
D10	00000000	01001100	00000000	01001011
D20	00000000	01001110	00000000	01010101
D30	00000000	00000000	00000000	00000000
D40	00000000	00000000	00000000	00000000
D50	00000000	00000000	00000000	00000000
D60	00000000	00000000	00000000	00000000
D70	00000000	00000000	00000000	00000000
D80	00000000	00000000	00000000	00000000
D90	00000000	00000000	00000000	00000000
D100	00000000	00000000	00000000	00000000
D110	00000000	00000000	00000000	00000000
D120	00000000	00000000	00000000	00000000
D130	00000000	00000000	00000000	00000000
D140	00000000	00000000	00000000	00000000

You can edit the numeric values of the data cell.

Double-click the device number column. The display setting dialog box will appear on the display.

Decimal data, table type

Register				
	+0	+2	+4	+8
D0	4395441	4456515	4587589	4718663
D10	4983811	5111885	5242959	5374033
D20	5636181	5767255	5898329	58851351
D30	0	1179648	13762578	79799961
D40	0	0	0	0
D50	0	0	0	0
D60	0	0	0	0
D70	0	0	0	0
D80	0	0	0	0
D90	0	0	0	0
D100	0	0	0	0
D110	0	0	0	0
D120	0	0	0	0
D130	0	0	0	0
D140	0	0	0	0

Hexadecimal data, table type

Register				
	+0	+2	+4	+8
D0	420041	440043	460045	480047
D10	40004B	4E004D	50004F	520051
D20	560055	580057	5A0059	3820017
D30	0	120000	D20012	46601A9
D40	0	0	0	0
D50	0	0	0	0
D60	0	0	0	0
D70	0	0	0	0
D80	0	0	0	0
D90	0	0	0	0
D100	0	0	0	0
D110	0	0	0	0
D120	0	0	0	0
D130	0	0	0	0
D140	0	0	0	0

ASCII data, table type

Register					
	+0	+2	+4	+6	+8
D0	A B	C D	E F	G H	I J
D10	K L	M N	O P	Q R	S T
D20	U V	W X	Y Z	.	z f
D40					
D50					
D60					
D70					
D80					
D90					
D100					
D110					
D120					
D130					
D140					

Floating-point data, table type

Register					
	+0	+2	+4	+6	+8
D0	1.5156275E0	1.53125799E0	1.54688323E0	1.56250846E0	1.5781337E0
D10	1.59375894E0	1.60938418E0	1.62500942E0	1.64063466E0	1.65625989E0
D20	1.67188513E0	1.68751037E0	1.70313561E0	7.64073391E-37	OE0
D30	OE0	1.140625E0	1.92854794E-38	2.70371324E-36	OE0
D40	OE0	OE0	OE0	OE0	OE0
D50	OE0	OE0	OE0	OE0	OE0
D60	OE0	OE0	OE0	OE0	OE0
D70	OE0	OE0	OE0	OE0	OE0
D80	OE0	OE0	OE0	OE0	OE0
D90	OE0	OE0	OE0	OE0	OE0
D100	OE0	OE0	OE0	OE0	OE0
D110	OE0	OE0	OE0	OE0	OE0
D120	OE0	OE0	OE0	OE0	OE0
D130	OE0	OE0	OE0	OE0	OE0
D140	OE0	OE0	OE0	OE0	OE0

Line type

Register					
	DEC	HEX	ASCII	BIT	FL0AT
D0	420041	420041	A B	00000000 01000010 00000000 01000001	1.5156275E0
D2	440043	440043	C D	00000000 01000100 00000000 01000011	1.53125799E0
D4	460045	460045	E F	00000000 01000110 00000000 01000101	1.54688323E0
D6	480047	480047	G H	00000000 01001000 00000000 01000111	1.56250846E0
D8	4A0049	4A0049	I J	00000000 01001010 00000000 01001001	1.5781337E0
D10	4C004B	4C004B	K L	00000000 01001100 00000000 01001011	1.59375894E0
D12	4E004D	4E004D	M N	00000000 01001110 00000000 01001101	1.60938418E0
D14	50004F	50004F	O P	00000000 01010000 00000000 01001111	1.62500942E0
D16	520051	520051	Q R	00000000 01010010 00000000 01010001	1.64063466E0
D18	540053	540053	S T	00000000 01010100 00000000 01010011	1.65625989E0
D20	560055	560055	U V	00000000 01010110 00000000 01010101	1.67188513E0
D22	580057	580057	W X	00000000 01011000 00000000 01010111	1.68751037E0
D24	5A0059	5A0059	Y Z	00000000 01011010 00000000 01011001	1.70313561E0
D26	5C005B	5C005B		00000011 10000010 00000000 00010111	7.64073391E-37
D28	0	0		00000000 00000000 00000000 00000000	OE0
D30	0	0		00000000 00000000 00000000 00000000	OE0
D32	1179648	120000		00000000 00010010 00000000 00000000	1.140625E0
D34	13762578	D20012	.	00000000 11010010 00000000 00010010	1.92854794E-38
D36	73793961	46601A9	z f	00000100 01100110 00000001 10101001	2.70371324E-36
D38	0	0		00000000 00000000 00000000 00000000	OE0
D40	0	0		00000000 00000000 00000000 00000000	OE0
D42	0	0		00000000 00000000 00000000 00000000	OE0
D44	0	0		00000000 00000000 00000000 00000000	OE0
D46	0	0		00000000 00000000 00000000 00000000	OE0

5.5.7 Tool Bar Status Bar Function Keys

OPN	L/V	L/M	I/V	S/V	S/M
	✓	✓	✓	✓	✓
—	C/V	R/V	D/L	D/M	SMP
	✓	✓	✓	✓	✓

Use these commands to change the application window display conditions.

Click Tool Bar to erase or redisplay the tool bar.

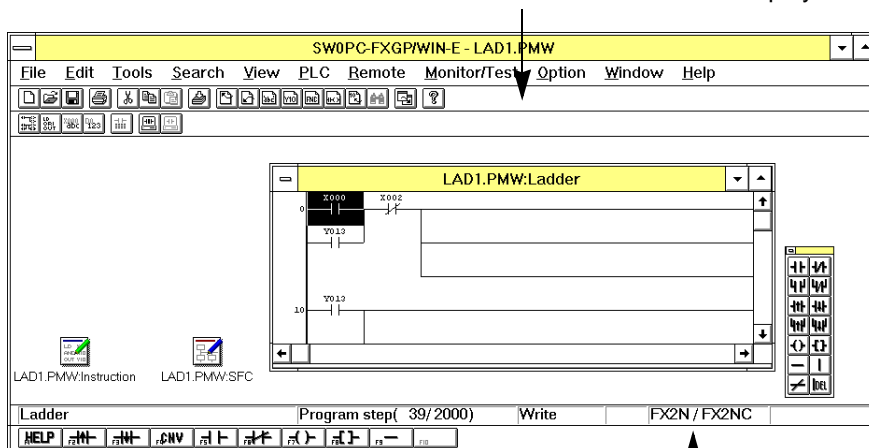

Click Function Keys to erase or redisplay the function key guidance.

Click Status Bar to erase or redisplay the status bar.

Functions of icons on tool bar

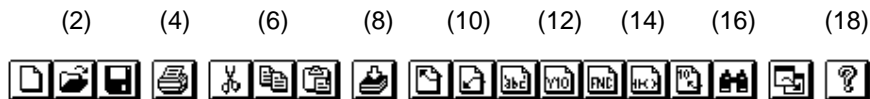

(1) (3) (5) (7) (9) (11) (13) (15) (17)

- (1) New (see Sec.5.1.1)
- (2) Open (see Sec.5.1.2)
- (3) Save (see Sec.5.1.4)
- (4) Print (see Sec.5.1.6)
- (5) Cut (see Sec.5.2.2)
- (6) Copy (see Sec.5.2.3)
- (7) Paste (see Sec.5.2.4)
- (8) Convert (see Sec.5.3.7)
- (9) Go to Top (see Sec.5.4.1)
- (10) Go to End (see Sec.5.4.1)
- (11) Device Name Search (see Sec.5.4.2)
- (12) Device Search (see Sec.5.4.3)
- (13) Instruction Search (see Sec.5.4.4)
- (14) Contact/ Coil Search (see Sec.5.4.5)
- (15) Go to Step (see Sec.5.4.6)
- (16) Search Next
- (17) Preferences (see Sec.5.8.10)
- (18) Help (see Sec.5.10)

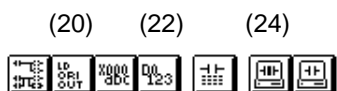

(19) (21) (23) (25)

- (19) Ladder view (see Sec.5.1.1)
- (20) Instruction view (see Sec.5.5.2)
- (21) Comment view (see Sec.5.5.5)
- (22) Register view (see Sec.5.5.6)
- (23) Comment display (see Sec.5.5.12)
- (24) Start monitor (see Sec.5.7.1)
- (25) Stop monitor (see Sec.5.7.2)

5.5.8 Palette

OPN	L/V	L/M	I/V	S/V	S/M
	✓				
—	C/V	R/V	D/L	D/M	SMP

Use this command to erase or redisplay the tool palette in the ladder diagram edit window.

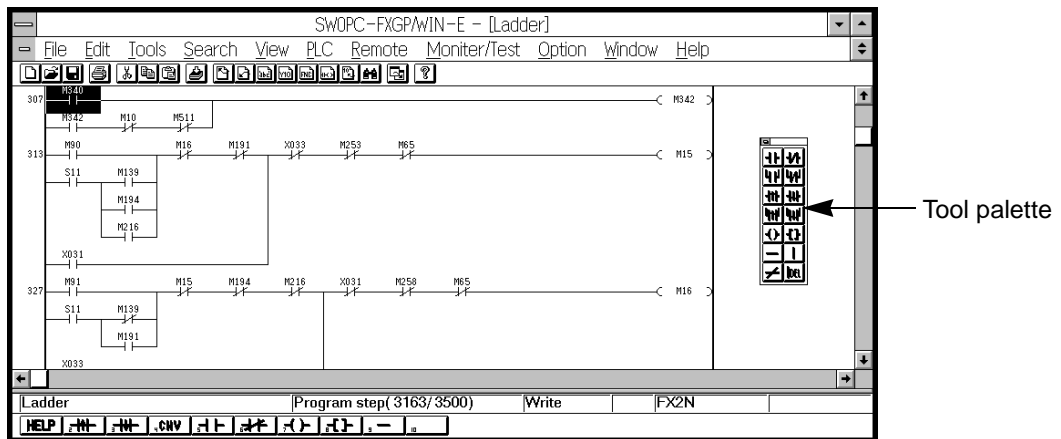

Various symbols, such as contacts, lines, and output coils, used for creating ladder diagrams are stored in the tool palette. Click the mouse button on a symbol in the tool palette to select the symbol.

This palette is a floating type. The palette, therefore, can be moved to another position so that you can easily use the mouse.

These symbols (contact, line, or coil symbols) can be also entered if you use the Tools command or function keys in place of the tool palette. The advantage of the tool palette is that you can change the circuit symbols without erasing the device entry dialog box.

5.5.9 Contact/Coil List

OPN	L/V	L/M	I/V	S/V	S/M
	✓		✓	✓	
—	C/V	R/V	D/L	D/M	SMP
	✓	✓	✓		

Use this command to display the step numbers in order to clarify the steps where the contact or coil of the specified device is used.

Use these buttons to scroll up and down the screen.

Use these buttons to switch the device.
 X→Y→M→S→T→C→D→P
 →I→N→V→Z

Enter the device number.
 The cursor positioned device number in the program window will be initially displayed.

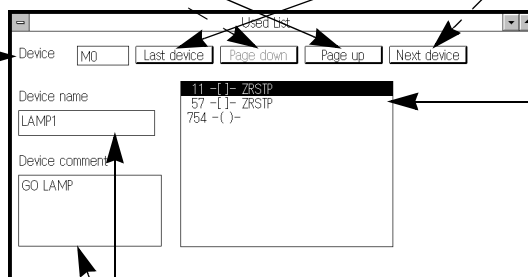

Displays the step numbers to clarify the steps where the contact or coil of the specified device is used.

Displays the comment on the specified device.

5.5.10 Device Used List

OPN	L/V	L/M	I/V	S/V	S/M
	✓		✓	✓	
—	C/V	R/V	D/L	D/M	SMP
	✓	✓	✓		

Use this command to display the contact/ coil use conditions of 24 devices. Specify the first device number to determine 24 devices.

Use these buttons to scroll up and down the screen.

Use these buttons to switch the device.
 X→Y→M→S→T→C→D→P
 →I→N→V→Z

Enter the device number.
 The cursorpositioned device number in the program window will be initially displayed.

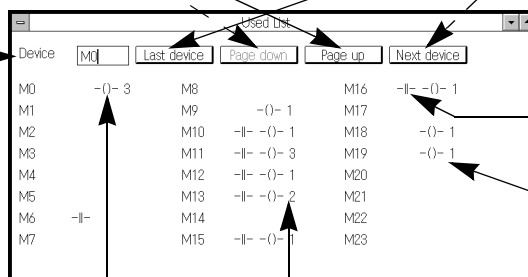

The symbol -| - will be displayed if the device uses a contact. No symbol will be displayed if the device uses no contact.

E1: No contact is used. Only coils are used.
 E2: No coils are used. Only a contact is used.

The symbol -() will be displayed if the device uses coils. No symbol will be displayed if the device uses no coils. The numeric value indicates the number of coils.

5.5.11 TC Setting List

OPN	L/V	L/M	I/V	S/V	S/M
	✓		✓	✓	
—	C/V	R/V	D/L	D/M	SMP
	✓	✓	✓		

Use this command to display the timer and counter values set in the program.

Use these buttons to scroll up and down the screen.

Click this button to switch the device.

Enter the device number.

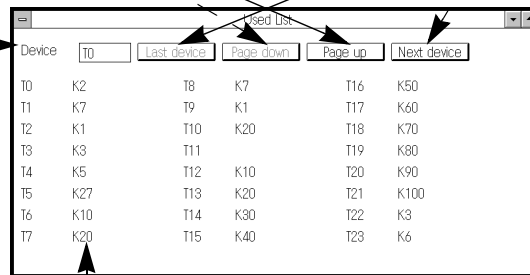

Displays the values set in the program.

The timer and counter values set in the program by the constants will be displayed on the above screen. To check the values indirectly set by the data register, etc., use the monitoring function or the data register display function.

5.5.12 Comment display

OPN	L/V	L/M	I/V	S/V	S/M
	✓	✓	✓	✓	✓
—	C/V	R/V	D/L	D/M	SMP

Use this function to specify the comments to be displayed in the ladder diagram edit window, list edit window, or SFC diagram edit window.

Ladder edit window

Specify the type of comments to be added to the ladder diagram.

Select the device comment display position; above the symbol or below the symbol.

Set the device comment display size. If the size is set as shown in the figure, the device comment of 10 characters x5 lines will be printed.

Set the coil comment display size. If the size is set as shown in the figure, the coil comment of 20 characters x7 lines will be printed.

Example: If all types of comments are specified

Device number

Device comment

Device name

Coil comment

Block comment

Example: If device names are displayed in place of device numbers

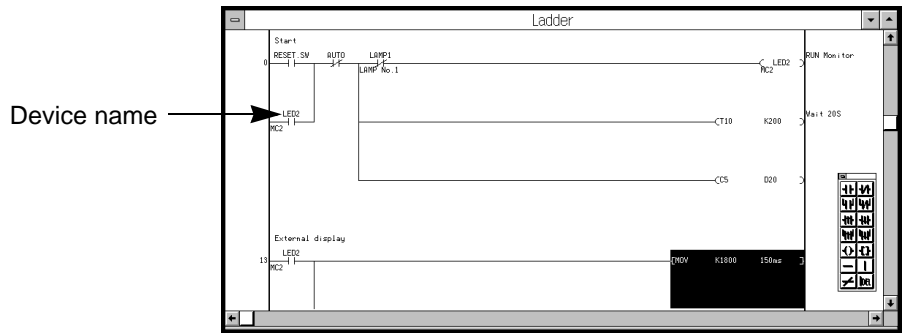

List edit window

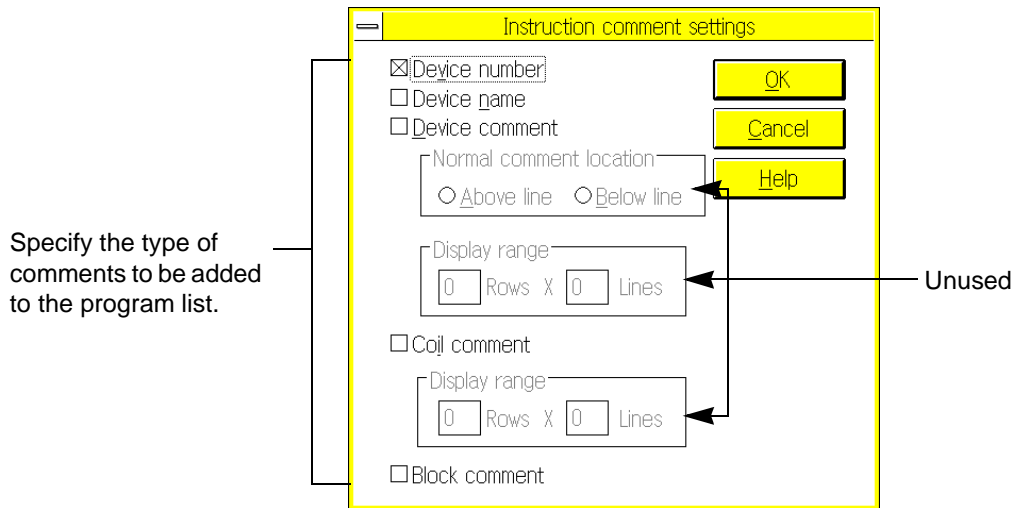

Example: If all types of comments are specified

Line No.	Instruction	Device	Parameter	Mode	Comment
7	OUT	T10	K200		Wait 20S
10	OUT	C5	D20		
External display					
13	LD	Y013			
		LED2			
		MC2			
14	MOV	K1500	D1		
19	SET	M30	150ms		
20	PLS	M35		Mode1	
22	OUT	Y000			
		LAMP1			
		LAMP No.1			
Counter coincidence signal					
23	LD	X002		Mode2	
		AUTO			
24	MC	N0	M50		
27	LD	X005			
		ZRN			
		ZRN			

Example: If device names are displayed in place of the device numbers

Line No.	Instruction	Device	Parameter	Mode	Comment
7	OUT	T10	K200		Wait 20S
10	OUT	C5	D20		
External display					
13	LD	LED2			
		MC2			
14	MOV	K1500	150ms		
19	SET	M30			
20	PLS	M35		Mode1	
22	OUT	LAMP1			
		LAMP No.1			
Counter coincidence signal					
23	LD	AUTO		Mode2	
24	MC	N0	M50		
27	LD	ZRN			
28	AND	LAMP1			
		LAMP No.1			
29	OUT	TEST			
		Ry3			

SFC diagram edit window

Specify the type of comments to be added to the SFC diagram.

Unused

Example: If all types of comments are specified

Device comment

Device number

Device name

5.5.13 Display Setting

OPN	L/V	L/M	I/V	S/V	S/M
—	C/V	R/V	D/L	D/M	SMP
				✓	

Use this command to specify the data register display size and device comment display style for the device store/monitor screen.

Select the data display method.

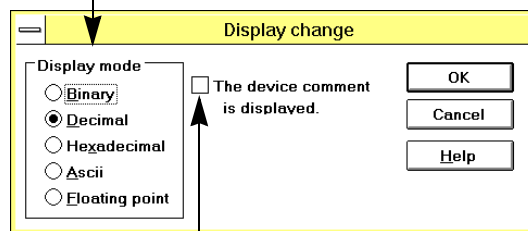

Click this box to display device comments on the device store/monitor screen.

5.5.14 Zoom

OPN	L/V	L/M	I/V	S/V	S/M
	✓		✓	✓	
—	C/V	R/V	D/L	D/M	SMP
	✓	✓			✓

Use this command to enlarge or reduce the characters displayed in the window.

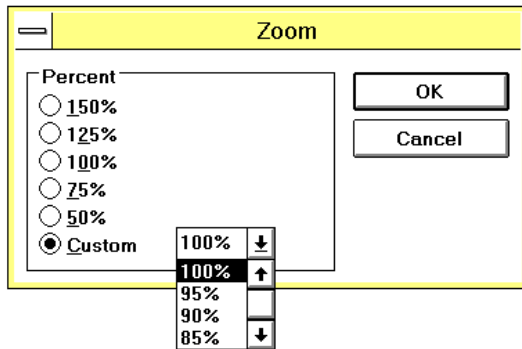

- Click Custom to specify the font size in the range of 50% to 150% in increments of 5%.
- To enlarge or reduce the characters displayed in the window, change the font size by clicking Option and then Font.
- The font size specified by the Zoom command will not affect the printed character size. To change the printed character size, click Scale in the printing data setting dialog box.

5.6 PLC Menu Functions

Use the commands on the PLC menu to execute online functions, such as data transfer to the programmable controller, programmable controller operation check, and setting/ displaying sampling trace data.

Connection to programmable controller:

Correctly connect the personal computer to the programmable controller while referring to Sec.1.2.3 "System configuration".

Solving communication error:

- 1) Check that the power is supplied to the programmable controller connected to the computer.
If no power is supplied, turn on the power of the programmable controller, and then restart operation.
- 2) Check the model names of the cable and the RS-232C/RS-422 interface unit connecting the personal computer to the programmable controller while referring to Sec.1.2.3 "System configuration".
If a wrong cable or interface unit is used, replace it with the right one. If the cable or interface unit is connected in a wrong way, correctly connect it.
- 3) Check all the connectors for looseness.
To prevent problems caused by looseness, tighten all the connectors, and then restart operation.
- 4) Check the communication port setting conditions for the communication port on the computer side. For a detailed description of the communication port, refer to Sec.5.6.10 "Ports".
- 5) If you have another peripheral unit of the FX series programmable controller, connect it in place of the current unit, and then communicate with the programmable controller.
If the peripheral unit enables proper communication, judge that the current unit, such as personal computer main body, cable, or interface unit, is defective. In this case, please contact us. We will check your system.

5.6.1 Transfers

OPN	L/V	L/M	I/V	S/V	S/M
	✓		✓	✓	
—	C/V	R/V	D/L	D/M	SMP
	✓	✓			

Use this command to read out programs from the programmable controller, write programs in the programmable controller, or collate program data.

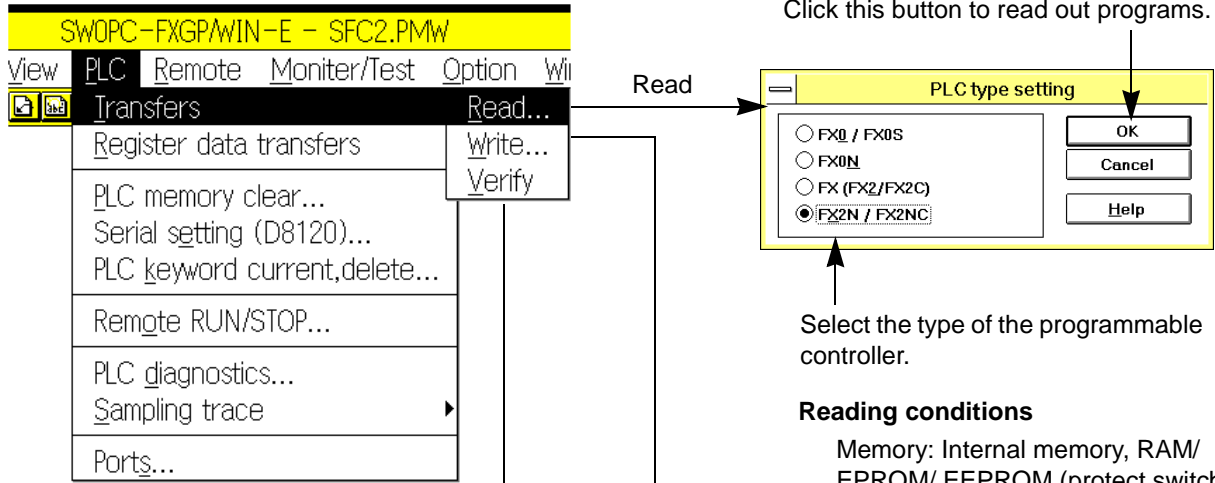

Click this button to read out programs.

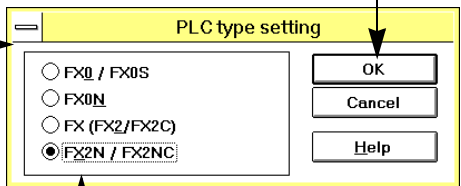

Select the type of the programmable controller.

Reading conditions

- Memory: Internal memory, RAM/ EPROM/ EEPROM (protect switch on or off) cassette
- Programmable controller operation mode: Run or stop mode

The program in the personal computer is compared with the program in the programmable controller to verify that all the steps have the same data. If there are steps having different data, the list of data error steps will appear (see the figure below). Click an error step. The step data stored in the personal computer and step data stored in the programmable controller are displayed, therefore you

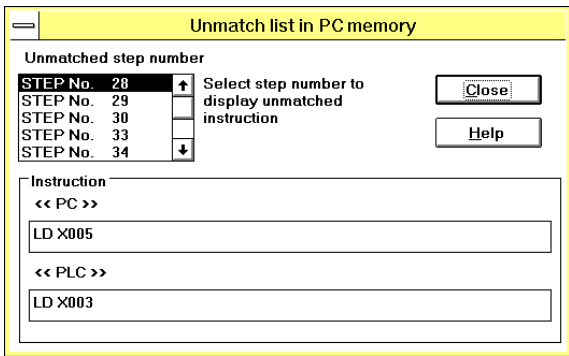

Note: If an instruction uses two or more steps, there may not be any difference in the data of an error step between the personal computer and the programmable controller.

Verify conditions

- Memory: Internal memory, RAM/ EPROM/ EEPROM (protect switch on or off) cassette
- Programmable controller operation mode: Run or stop mode

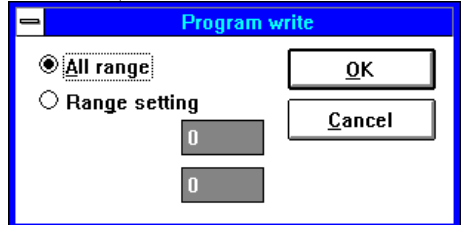
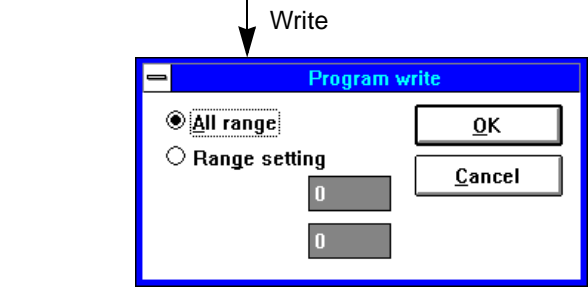

Transfers programs from the personal computer to the programmable controller. When "Range setting" is selected, the specified step range exclusively will be transferred.

Writing conditions

- Memory: Internal memory, RAM/ EEPROM (protect switch off) cassette
- Programmable controller operation mode: Run or stop mode



Program transfer operation

- Use Parameter and Program (File Register,comment) to transfer all the programs at a time. Note that it takes 3 to 4 minutes to transfer the programs of 1.6 K steps to the FX-EEPROM-16.
- If the keyword is stored, the Keyword dialog box will appear on the display. Enter the keyword.If a wrong keyword is entered, operation will be stopped.

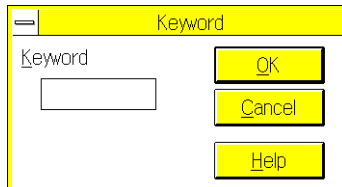

- When a program is transferred from the personal computer to the programmable controller, program verification will be automatically executed after writing the program. To skip the program verification step, click Preference (see Sec. 5.8.10). The Preference window will appear. In the Automatically Verify box of this window, click the No button.
- The Device comment and File register cannot be written to the FX0 and FX0s PC. Please initialize the Parameter settings by Options.

Control of parameter-set comments

- If a sequence program has parameter-set comments, the FXGP/WIN-E will read out these comments as the device comments. In addition, these device comments will be regarded as the comments to be written in the programmable controller. (See Sec. 1.4 and Sec. 5.5.5.)
- The device comments regarded as the comments to be written in the programmable controller will be written in the program area of the programmable controller. (See Sec. 1.4, Sec. 5.2 13, and Sec. 5.3.9.)

5.6.2 Register Data Transfers

OPN	L/V	L/M	I/V	S/V	S/M
	✓		✓	✓	
—	C/V	R/V	D/L	D/M	SMP
	✓	✓			

Use this command to read out register data from the programmable controller, write register data in the programmable controller, or collate register data.

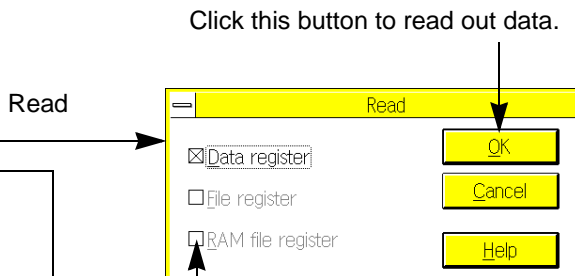
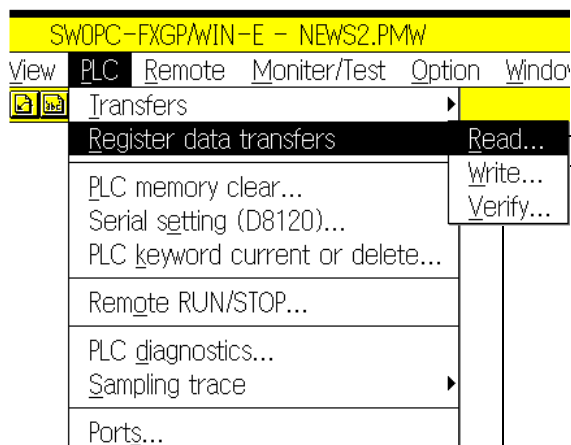

Click this button to read out data.

Specify the items to be read out.

Reading conditions

Memory: Internal memory, RAM/ EPROM/ EEPROM (protect switch on or off) cassette
 Programmable controller operation mode: Run or stop mode

Click this button to write data.

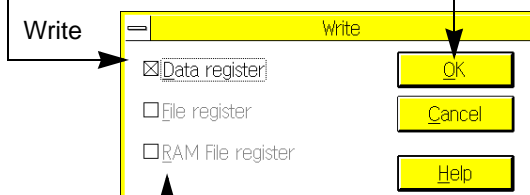

Specify the item to be written.

Writing conditions

Memory: Internal memory, RAM/ EEPROM (protect switch off to write file register data/protect switch on to write the other register data) cassette
 Programmable controller operation mode: Stop mode (writing impossible in run mode)

Collates the program on the personal computer side with that of the programmable controller.

Verify conditions

Memory: Internal memory, RAM/ EPROM/EEPROM (protect switch on or off) cassette
 Programmable controller operation mode: Run or stop mode

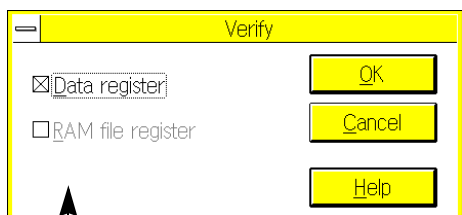

Specify the item to be collated.



- If the keyword is stored, the Keyword dialog box will appear on the display. Enter the keyword. If a wrong keyword is entered, operation will be stopped.

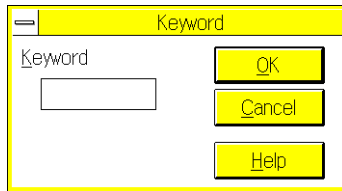

- To use the file register, set the parameter to ensure enough free area.
To use the RAMfile register data, turn on the special auxiliary relay (M8074) on the programmable controller side.
The file register and RAMfile register will be valid only if the programmable controller having these register functions is selected.

5.6.3 PLC Memory Clear

OPN	L/V	L/M	I/V	S/V	S/M
	✓		✓	✓	
—	C/V	R/V	D/L	D/M	SMP
	✓	✓			

Use this command to clear the memory of the programmable controller using the personal computer in the online mode.

Click this button to clear the program memory of the programmable controller. (Programs + file registers + parameters)

Command execution conditions

Memory: Internal memory, RAM/ EEPROM (protect switch off) cassette

Programmable controller operation mode: Stop mode (execution impossible in run mode)

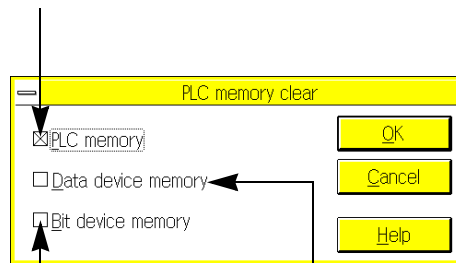

Click this button to turn off all the bit devices (X, Y, M, S, T, and C). In addition, clicking this button will reset the current timer and counter values to zero.

Click this button to clear all the data registers (D), file registers (D), and RAM file registers (D).

Command execution conditions

Memory: All memories

Programmable controller operation mode: Stop mode (execution impossible in run mode)

Command execution conditions

Memory: Internal memory, RAM/ EEPROM (protect switch off) cassette

Programmable controller operation mode: Stop mode (execution impossible in run mode)

5.6.4 Serial Setting (D8120)

Use this command to set the communication format in the special data register (D8120) if the programmable controller uses the RS-232C communication adapter.

Click this button to set the data.

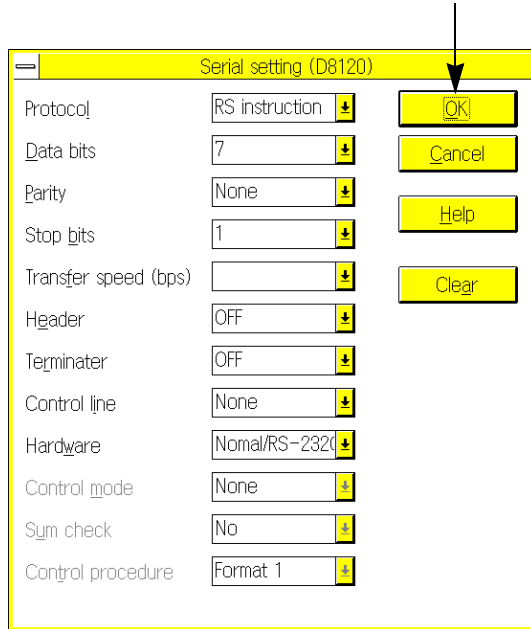

- If communication data is still not set in the D8120, the values shown in the left figure will appear on the Serial Setting screen.
- If communication data is already set in the D8120, the set values will appear on the Serial Setting screen.
- Click OK to directly write the set values in the D8120 of the programmable controller. In addition, the same data will be written in the data register area on the personal computer side. For this reason, when you use the Register Data Transfer command to transfer all the register data to the programmable controller, the D8120 data set on this screen will be written in the programmable controller again.

Command execution conditions

Memory: Internal memory, RAM/ EPROM/ EEPROM (protect switch on or off) cassette

Programmable controller operation mode: Run or stop mode

5.6.5 PLC Keyword Current or Delete

OPN	L/V	L/M	I/V	S/V	S/M
	✓		✓	✓	
—	C/V	R/V	D/L	D/M	SMP
	✓	✓			

Use this command to store the keyword in the program memory of the programmable controller, change the keyword, or delete the keyword.

Store the keyword if you want to protect the programs from being erased by mistake (due to overwrite) or being stolen.

Click this button to store the keyword.

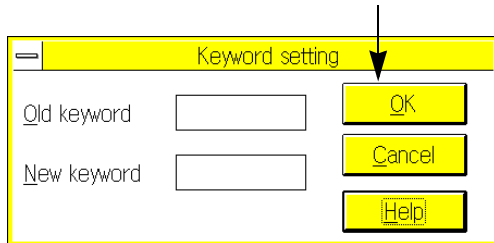

Store

Enter a keyword in the New Keyword box to store the keyword.

Change

Enter an old keyword in the Old Keyword box, and then enter a new keyword in the New Keyword box. After that, press the OK button to change the old keyword to the new keyword.

To delete a keyword, enter the keyword in the Old Keyword box, and then enter 8 characters of spaces. After that, press the OK button.

Command execution conditions

Characters used for keyword: Alphanumeric characters of A to F and 0 to 9

Number of characters: 8 characters (An error will be detected if the number of characters is less than 8.)

Memory: Internal memory, RAM/ EPROM/ EEPROM (protect switch on or off) cassette Programmable controller operation mode: Run or stop mode



When the registered keyword is unknown

When the registered keyword is unknown, the keyword cannot be changed nor canceled. When deleting an entire program including the keyword, execute "PLC → PLC memory clear".

Setting keyword protection level for peripheral online units

If the peripheral units enable online operation with the programmable controller FX-10P, FX-20P, etc., you can set the protection level for the keyword. There are three protection levels as described below. If you want to protect the programs from being monitored or modified by the online units, set the keyword of optimum protection level.

All operations impossible (No peripheral units enables operation.):

A□□□□□□ OR ■ □□□□□□

↑
Enter an alphanumeric character other than A, B, or C.

Protection from steal (Monitoring, data modify, etc.will be inhibited.):

B□□□□□□

Protection from overwrite (Reading, monitoring, data modify, etc.will be inhibited.):

C□□□□□□

In the empty boxes □ , enter alphanumeric characters to determine the keyword.You can use alphanumeric characters of A to F and 0 to 9.



Keyword check and entry

- If a keyword is set, you have to enter the keyword at starting next operation.
The system checks the keyword you entered. If a wrong keyword is entered, a dialog box will appear on the display, and request you to enter the right keyword.
The keyword will be checked,
 - 1) When programs are read out from the programmable controller, when programs are written in the programmable controller, or when programs in the programmable controller are collated.
 - 2) When programs are read out from the memory cassette installed on the ROMwriter, or when programs in the memory cassette are collated.
The system will not check the keyword when you use the file data stored in the floppy disks or hard disk.
- Enter the keyword,
 - 1) When you change or delete the keyword using PLC and then PLC Keyword Current or Delete.
 - 2) When you use the programmable controller or ROM writer for data reading or writing.
If a keyword is set for the programmable controller or ROM cassette, the keyword entry dialog box will appear on the display when programs are read out from the programmable controller or ROM cassette. If the right keyword is entered, the programs will be read out.
If a keyword is set for the programmable controller, the keyword entry dialog box will appear on the display when data is written in the programmable controller. If a wrong keyword is entered, no data will be written in the programmable controller.
To write data in the ROM writer, the data in the EPROM cassette should be erased using ultraviolet ray. For this reason, the keyword entry dialog box will not appear on the display.
If the keyword stored in the programmable controller differs from that of the personal computer, the keyword in the programmable controller will have the priority. For this reason, if the keyword entry dialog box appears at writing data (to transfer programs), enter the keyword of the programmable controller.
- In the offline mode, click Option and then Keyword Setting to store a keyword in the personal computer only, to change the keyword stored in the personal computer only, or to delete the keyword from the personal computer only. If you use Option and Keyword Setting, the password in the personal computer will be changed, but the password in the programmable controller will not be changed.

5.6.6 Runtime Program Changes

OPN	L/V	L/M	I/V	S/V	S/M
	✓				
—	C/V	R/V	D/L	D/M	SMP

When the programmable controller is in the run or stop mode, use this command to change programs in the ladder diagram edit window. The changed programs will be directly written in the program memory of the programmable controller.

Data writing method

- Using this command, you can modify the existing ladder diagram in the ladder diagram edit window (add, insert, or delete in units of ladder symbols), and can insert or add ladder blocks (but ladder block delete is not possible). Such modification range is limited to one ladder block. If two or more blocks are modified at a time, the program cannot be written in the program memory in the run mode. For the data writing conditions in the run mode, refer to the next page.
- Press the **Shift** and **F4** keys (RUN CNV) or PLC and Runtime Program Change to write the changed data in the program memory in the run mode.

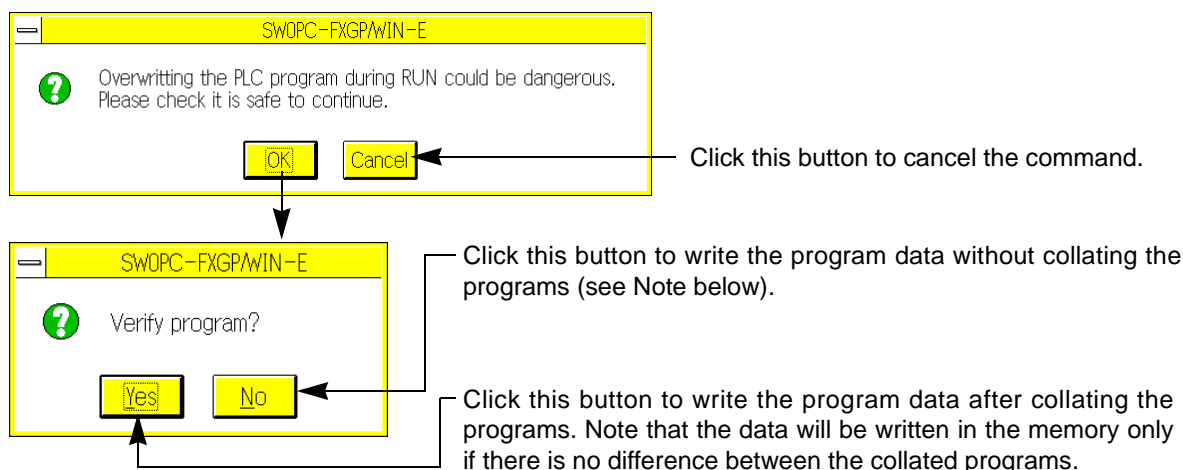

- If a program is changed in the run mode, the programmable controller will change the control sequence. Carefully change programs in the run mode for the safety reasons. For a detailed description, refer to the operation manual of the programmable controller that describes how to write data in the run mode.
- Before starting operation, be sure to check that the same programs are stored in both the programmable controller and the personal computer. If operation is started with different programs, the programs stored in the programmable controller may be destroyed.
- When "Convert and run time program changes" is selected by "Option → Preferences", "Run time program changes" is executed also after "CNV F4" or "Tools → convert" is executed.
- Carefully write pulse application instructions (with P) in the ladder diagram. This is because the instruction written in the diagram will be executed if the input condition is ON.

Program change conditions

Hardware

Model: FX_{2C} series
FX series (version 2.1 or above)
FX_{0N} series (version 1.10 or above)
FX_{2N},FX_{2NC} series

Memory type: Internal RAM, optional RAM cassette, or optional EEPROM cassette (protect switch off) for FX_{2N},FX_{2NC} series
Internal RAM or optional RAM cassette for FX and FX_{2C} series
Internal EEPROM for FX_{0N} series Programmable controller operation mode: Run or stop mode

Program

Items common to programmable controller FX_{0N}, FX, FX_{2C}, and FX_{2N},FX_{2NC} series:

- 1) When you change a ladder diagram, you can change only one circuit block at a time. In addition, before and after change, the number of program steps included in the block should be 127 or less (including the NOP just after the circuit block, but for the final block, excluding the NOP just after the block). If you change more programs, use the Transfers command to transfer all the programs.
- 2) When you modify a circuit block, the label P or I should not be added, deleted, or changed.
- 3) If a circuit block before or after modification include high-speed counter C235-C255 output instruction (OUT) or application instruction FNC 90-98, modification of the block will not be possible.
- 4) When you modify a circuit block, no lms timer can be newly inserted.

Notes regarding use of programmable controller FX (version 3.07 or above) or FX_{2C} series:

- 1) For new instructions, you cannot insert substitute instructions in the program, or replace new instructions with substitute instructions. If substitute instructions are in the program, they will not function in the run mode.
- 2) For the above programmable controllers, the CMP, ZCP, and MOV commands (FNC10 through FNC12) and ADD, SUB, MUL, DIV, INC, and DEC commands (FNC20 through FNC25) ensure high-speed operation only if the digits of word devices are specified or if no indexes are used for modification. These commands, however, will not ensure high-speed operation when data is written or inserted in the run mode.
- 3) For the FX (version 3.07 or more) and FX_{2C} series, the application command OFF time is reduced. However, if data is written or inserted in the run mode, this time reduction function will not be valid, and the command OFF time will be increased by approximately 60% for the FX (version 2.30 or less) series. At the completion of data writing in the run mode, change the mode of the programmable controller to stop and then run again. The above functions 1) through 3) will be valid again.

Notes regarding use of programmable controller FX series (version 2.1 to version 2.30):

- 1) Application instructions or device numbers added by the programmable controller FX series (version 3.07 or more) will be written in the program memory of the programmable controller. At this moment, the system will not check these instructions, and the programmable controller will continue operation. However, when the mode of the programmable controller is switched to stop and then run again, the system will check the programs. When the PROG-ELED indicator lamp will flash, correct the corresponding instructions or device numbers, and then transfer all the acceptable programs at a time.
- 2) Even if a device number invalid for the FX series (version 3.07 or more) is specified by the operand of the application instruction, the instruction will be written in the program memory of the programmable controller. At this moment, an operation error (wrong device number) will be detected on this instruction. The programmable controller, however, will continue operation, ignoring the error. When the mode of the programmable controller is switched to stop and then run again, the system will check the programs, and the PROG-ELED indicator lamp will flash. Correct the operand of the application instruction, and then transfer all the programs at a time.

Notes regarding use of programmable controller FX_{0N} series (version 1.10 or above):

- 1) If a device number invalid for the FX_{0N} is written, the message "Ladder diagram creation error" will appear on the display, and the program will not be changed.
- 2) The FX_{0N} cannot execute any pulse type application instructions. If you write such instructions, the message "Writing error" will appear on the display, and the program will not be changed.
- 3) Even if a new application instruction invalid for the FX_{0N} series is inserted, the instruction will be written in the program memory of the programmable controller. At this moment, the system will not check the instruction, and the programmable controller will continue operation. However, when the mode of the programmable controller is switched to stop and then run again, the system will check the programs. When the PROG-E LED indicator lamp will flash, correct the corresponding instruction, and then transfer all the acceptable programs at a time.
- 4) Even if a device number invalid for the FX series (version 3.07 or more) is specified by the operand of the application instruction, the instruction will be written in the program memory of the programmable controller. At this moment, an operation error (wrong device number) will be detected on this instruction. The programmable controller, however, will continue operation, ignoring the error. When the mode of the programmable controller is switched to stop and then run again, the system will check the programs, and the PROG-ELED indicator lamp will flash. Correct the operand of the application instruction, and then transfer all the programs at a time.

For a detailed description, refer to the handy manual of the programmable controller.

Writing data in run mode

- Even if the number of program steps is reduced by change in the program, the programmable controller will not reduce the total number of steps, but will add NOP instructions to balance the number of steps.

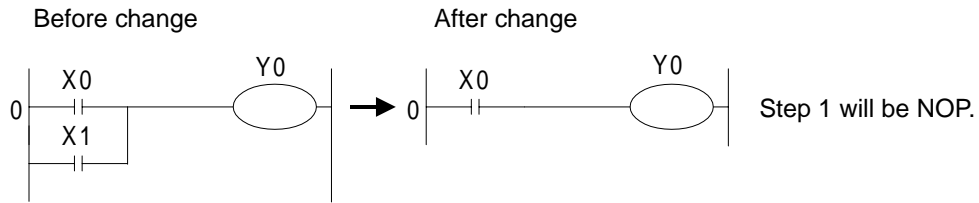

- If the number of program steps is increased by change in the program, programs will be inserted to balance the number of steps.

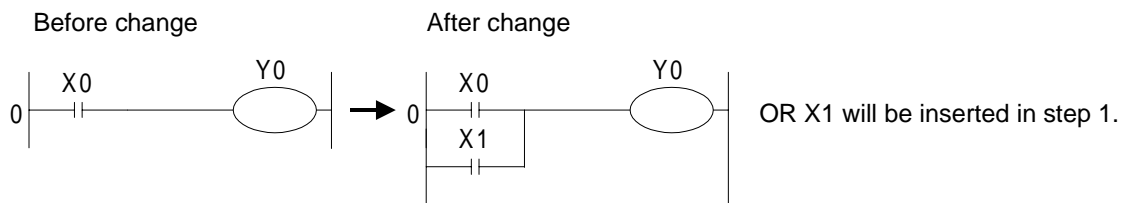

5.6.7 Remote Run/Stop

OPN	L/V	L/M	I/V	S/V	S/M
	✓	✓	✓	✓	✓
—	C/V	R/V	D/L	D/M	SMP
	✓	✓	✓	✓	✓

Use this command to run or stop the programmable controller FX2N series using the personal computer. For these operations (remote run and stop), the special auxiliary relays M8035 (forced run mode), M8036 (formed run), and M8037 (forced stop) will be controlled. Note that remote stop will be valid even if the RUN/STOP switch of the programmable controller is at the RUN position.

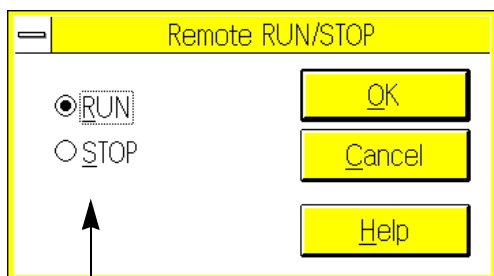

Select Run or Stop, and then click the OK button.

5.6.8 PLC Diagnostics

OPN	L/V	L/M	I/V	S/V	S/M
	✓		✓	✓	
—	C/V	R/V	D/L	D/M	SMP
	✓	✓			

Use this function to display the scan time (operation cycle) and error detected on the programmable controller connected to the personal computer.

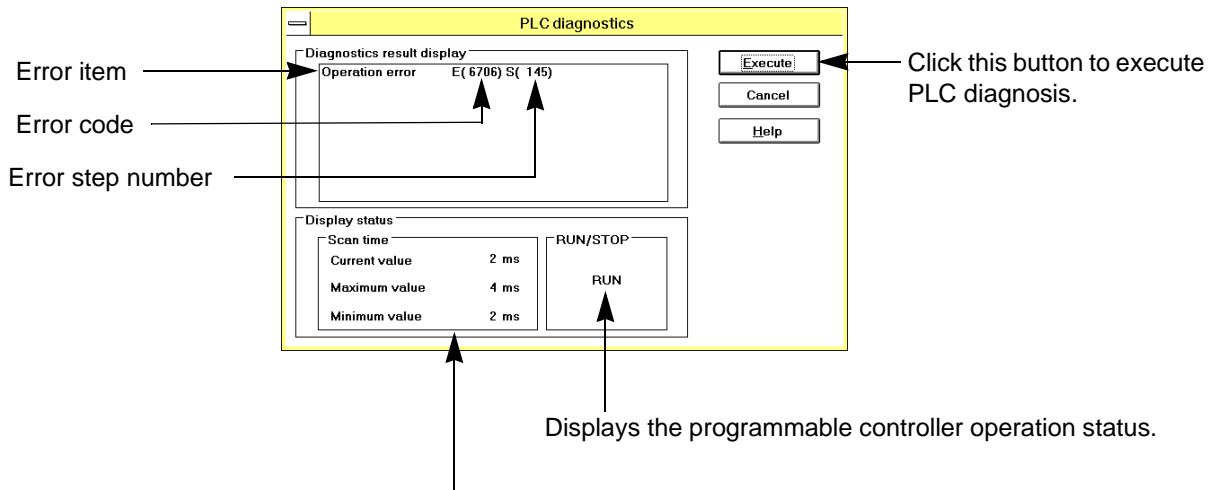

Displays the data stored in the special data registers of the programmable controller.
 Current value : D8010
 Maximum value : D8011
 Minimum value : D8012

For a detailed description of error codes, refer to the APPENDIX.

5.6.9 Sampling Trace

OPN	L/V	L/M	I/V	S/V	S/M
	✓		✓	✓	
—	C/V	R/V	D/L	D/M	SMP
	✓	✓			✓

Use this command to sample data at the specified time under the specified trigger conditions. The items to be subject to sampling trace are on/ off operation of the specified devices and change in the numeric values. Sampling trace will be executed by the programmable controller. The FXGP/WIN-E will set the sampling conditions and display the result of sampling trace.

Applicable programmable controller: FX, FX_{2C} and FX_{2N},FX_{2NC} series

The screenshot shows the 'Sampling trace' menu in the SWOPC-FXGP/WIN-E software. The menu items are: 'Setting parameters...', 'Run...', 'Display result', 'Read from result file...', and 'Write to result file...'. The 'Setting parameters...' option is highlighted. Four arrows point from text instructions to these options:

- An arrow points to 'Setting parameters...' with the text: "Click this command to set the sampling conditions."
- An arrow points to 'Run...' with the text: "Click this command to transfer the set data to the programmable controller."
- An arrow points to 'Display result' with the text: "Click this command to display the sampling results."
- An arrow points to 'Write to result file...' with the text: "Click this command to store or read out the sampling results."

Setting Parameters

Use this command to specify the devices subject to sampling trace, and also specify the tracing time and the number of tracing times.

In addition, if you want to use a device as the trigger for tracing, you can specify the device.

Trace Count :
Set the total number of tracing times in this box.
The setting range is from 0 to 512 times.

Trace Time :
Set the tracing time in this box.
The setting range is from 1 to 200.
If you set "0", sampling will be performed when the END instruction is executed.

New Condition : Click this button to store all the new conditions.
Last Data : Click this button to display the last data.
Read from PLC : Click this button to read out the conditions from the programmable controller.

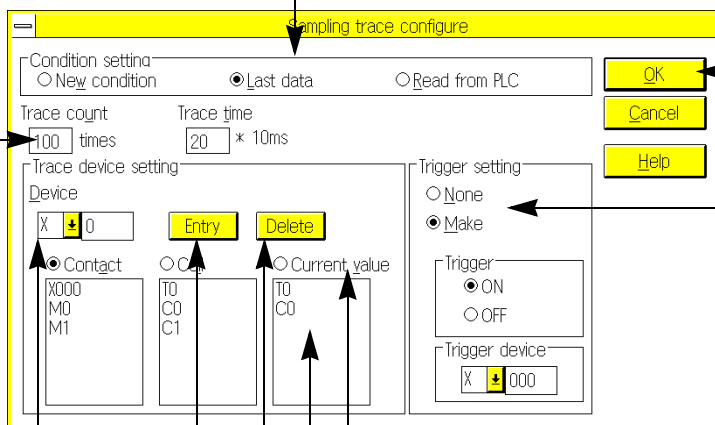

Click this button at the completion of data setting.

Click this button to specify special device operation as the tracing start point.

Enter the device number to be stored.

Select a directory.

Displays the stored data.

Click this button to store the specified devices in the specified directory.

Click this button to delete the cursor-positioned device.

Applicable devices:

Contact	: X, Y, M, S, T, C] Up to 10 devices
Coil	: T, C (Y, M*1)	
Current Value	: T, C, D, Z, V] Up to 3 devices

*1: Devices Y and M can be stored in the Coil list. However, depending on the operation of the programmable controller, the coil on/off operation may not be sampled. For this reason, store devices Y and M in the Contact list.

Run

Use this command to transfer the sampling conditions to the programmable controller, or read out the tracing results from the programmable controller. In addition, use this command to start or stop tracing.

Click this button to transfer the set sampling conditions (described before) to the programmable controller connected to the personal computer. Note that data writing will not be possible if "Start" is inverted.

Displays the tracing status. The current tracing status will be inverted.

Click this button to start sampling trace. While the programmable controller is in the tracing mode, "Start" will be inverted.

Click this button to perform forced stop-page of sampling trace.

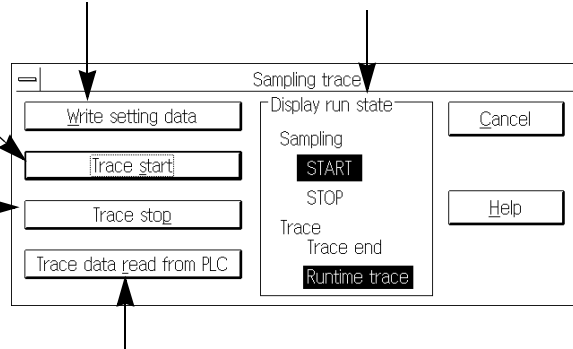

Click this button to read out the results of sampling trace from the programmable controller. Use the Display Result command to display the results read out.

Operation while specifying trigger:

Sampling will be performed while observing the specified tracing time until the trigger conditions are satisfied. When satisfied, sampling will be performed while observing the specified tracing time, and then completed when the number of tracing times equals the specified number (specified by Trace Count).

Display result

Use this command to display the results of the sampling trace read out from the programmable controller.

The screenshot shows a window titled "Sampling Trace Data Display" with the following parameters: Number of traces: 100, Trace time: 200 ms, Trigger device: ON, X000.

	Condition	12	13	14	15	16	17	18	19	Comment	
X000 - -	ON	[Timing Diagram: Signal_A]									Signal_A
M0 - -	ON	[Timing Diagram: Output_1]									Output_1
M1 - -	OFF	[Timing Diagram: Output_2]									Output_2
T0 -()-	ON	[Timing Diagram: Wait K20]									Wait K20
C0 -()-	ON	[Timing Diagram: GO]									GO
C1 -()-	ON	[Timing Diagram: GO]									GO
T0 -[]-	20	[Timing Diagram: Wait K20]									Wait K20
C0 -[]-	86	[Timing Diagram: GO]									GO

Annotations:

- Device to be traced:** Points to the X000 device in the first row of the table.
- Displays the up to 30 characters of device comment:** Points to the Comment column in the table.
- Device types stored:**
 - | |-: Contact
 - ()-: Coil
 - []-: Current Value
- Move the trace bar using the mouse:** Points to the vertical trace bar in the timing diagram.

Read from Result File

Use this command to read out the results of sampling trace and the set conditions from the file.

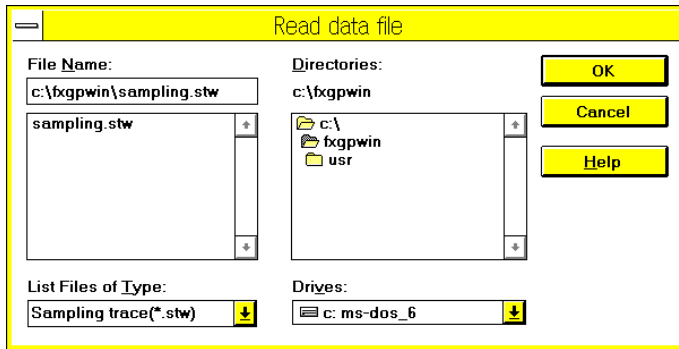

Write to Result File

Use this command to store the results of sampling trace and the set conditions in a file.

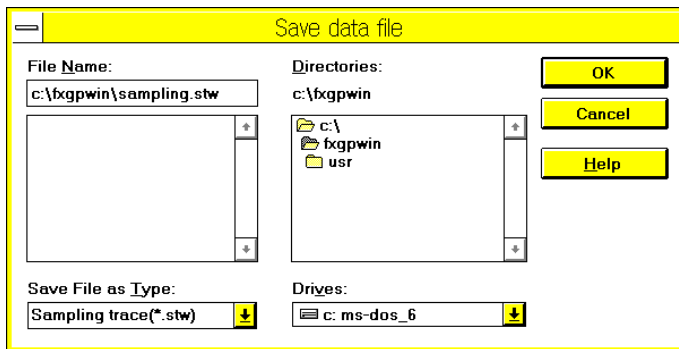

5.6.10 Ports

OPN	L/V	L/M	I/V	S/V	S/M
✓	✓		✓	✓	
—	C/V	R/V	D/L	D/M	SMP
	✓	✓			

Use this command to select an RS-232C port of the personal computer in order to connect the programmable controller or ROM writer to the computer.

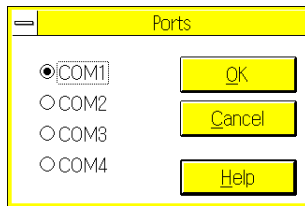

Select the port from COM1 through COM4 considering the personal computer system configuration.

5.7 Monitor/Test Menu Functions

On the Monitor/Test menu, there are two types of commands; monitoring commands and testing commands. The monitoring commands enable you to monitor operation of the programmable controller displayed in the ladder diagram, device, or SFC diagram window. The testing commands directly control the devices in the programmable controller and numeric values.

Connection to programmable controller

To execute commands of the Monitor/Test menu, the personal computer should be connected to the programmable controller. For a detailed description of connection, refer to Sec.5.6 "PLC Menu Functions".

5.7.1 Start monitor

OPN	L/V	L/M	I/V	S/V	S/M
	✓			✓	
—	C/V	R/V	D/L	D/M	SMP

Use this command to monitor operation of the programmable controller using the ladder or SFC diagram edit window.

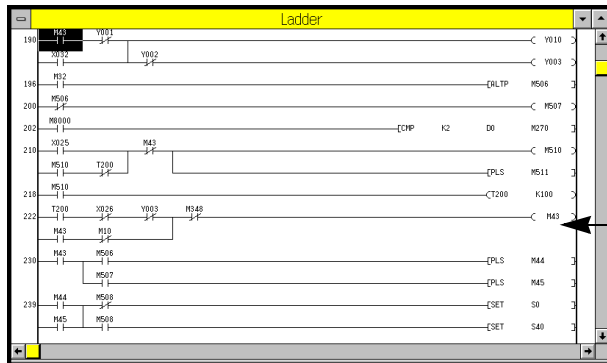

- At any status of the edit window, click Monitor/Test and then Start Monitor to monitor operation of the programmable controller.

Ladder diagram edit window

- Before monitoring operation of the circuits, check that the programs stored in the personal computer are the same as those of the programmable controller. If there is difference between these programs, wrong monitoring results may be shown on the display.

Monitor/Test → Start Monitor

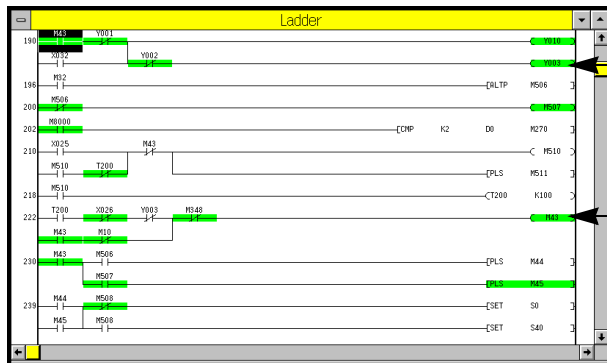

Contacts connected and coils activated will be inverted into green.

Double-click the mouse button on an output instruction, such as timer, counter, or application instruction, to modify the set value (see Sec.5.7.8).

Displaying current values on circuit monitor

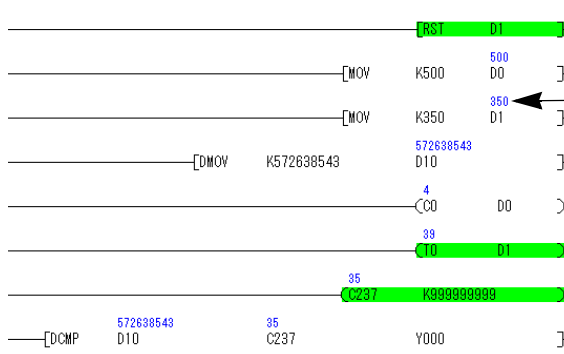

If the following devices are included in the OUT instruction or application instruction, the current values will be displayed on the monitor screen. (For the indirectly specified timers, counters, and devices included in the RST instruction, the current values will not be displayed.)

- . Timer (T)
- . Counter (C)
- . Data register (D)
- . Index register (V, Z)

- Index-modified devices in application instructions will be controlled as follows:
 - The current values of index-modified devices only will be displayed.
 - The current values of index-modified devices will not include the index modification result.
 - The current values of index registers (V and Z) will be displayed only if one index register (V or Z) is specified in the operand.
- The current values will be displayed using decimal numbers or hexadecimal numbers ("H" will be added to the top of the value).
 To switch the current value display style between decimal and hexadecimal numbers, click Monitor/Test and then Display Change of Monitor Data ()(see Sec. 5.7.9).

Monitoring circuits and operation of each device

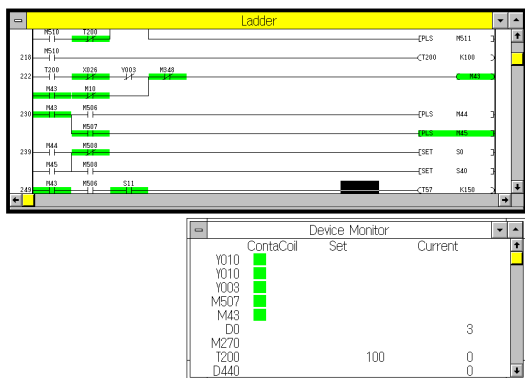

Use Entry Device Monitor (described later) to monitor respective devices. Select a device, and you can monitor the following items at the same time:

- Operation of the contact and coils of the selected device
- Timer/counter setting value and current timer/counter value
- Current data register value

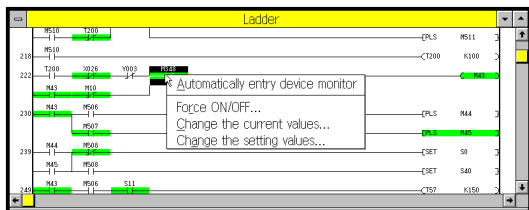

To monitor a device, click the right button of the mouse on the desired device in the ladder diagram. The shortcut menu will appear on the display as shown in the figure.

For a detailed description, refer to the description of each command.

5.7.2 Stop Monitor

OPN	L/V	L/M	I/V	S/V	S/M
		✓			✓
—	C/V	R/V	D/L	D/M	SMP

Use this command to stop monitoring of the programmable controller operation. The ladder diagram edit window used for monitoring will return to the edit mode.

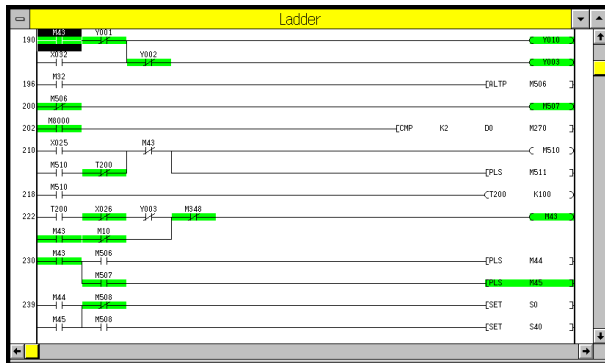

The ladder diagram edit window is in the monitoring mode. You cannot edit the ladder diagram using the change or delete functions.

Monitor/Test → Stop Monitor

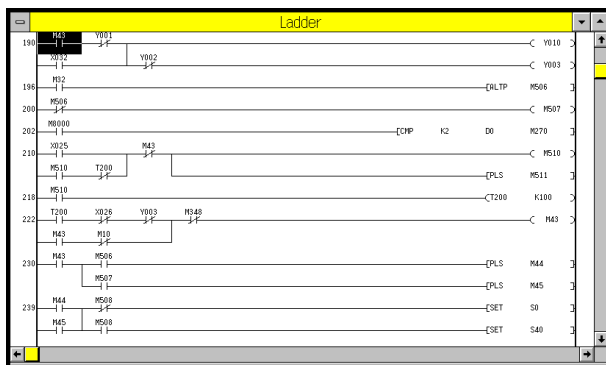



Monitoring will be stopped, and you can edit the ladder diagram.

5.7.3 Dynamic Monitor

OPN	L/V	L/M	I/V	S/V	S/M
				✓	
—	C/V	R/V	D/L	D/M	SMP

Use this command to automatically read out the operating state data, and to monitor operation of the states displayed in the SFC diagram.

The screen will be automatically scrolled up, down, rightward, or leftward as the active state is switched.

- To enable automatic monitoring using the SFC diagram, be sure to turn on the special auxiliary relay M8047.
- If two or more states are active in the translation circuit, use the  and  keys to switch the active state to be automatically monitored.

Automatic monitoring of translation branches:

To monitor a triple translation circuit shown in the ladder diagram, press the  key once to monitor the devices of the first branch, twice to monitor the devices of the second branch, and three times to monitor the devices of the third branch. (Up to 8 branches can be monitored.)

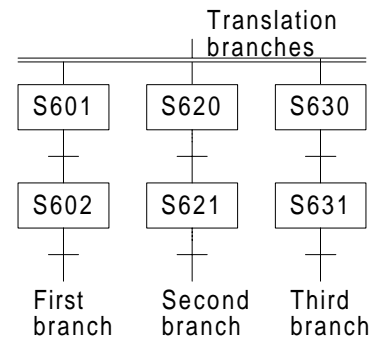

5.7.4 Entry Device Monitor

OPN	L/V	L/M	I/V	S/V	S/M
	✓	✓	✓	✓	✓
—	C/V	R/V	D/L	D/M	SMP
	✓	✓		✓	

Use this command to monitor the specified device.
 Enter a device number to specify the device, and you can monitor the following items.

- Operation of the contacts and coils of the specified devices
- Timer/counter setting values and current timer/ counter values
- Current data register values

The device store/ monitor window can be overlapped on the ladder diagram edit window.

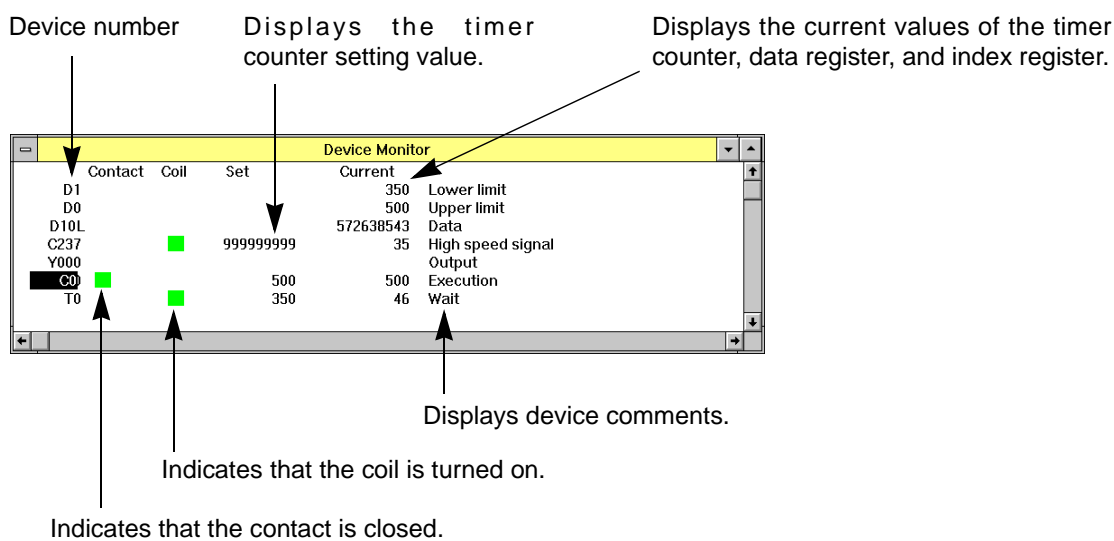

Applicable devices

X, Y, M, S, T, C, D, V, Z

Number of storage points

48 points, maximum

Saving and reading the information on registered devices

The element symbols registered in "Entry device monitor" can be saved as a registration monitor file. An existing registration monitor file can be read to the current program file.
 In the state in which the device monitor window is selected, perform the following operation.

- When saving a registration monitor file: File → Export
- When reading an existing registration monitor file: File → Import

Display style:

- The data register (D) values can be displayed using binary numbers, hexadecimal numbers, ASCII numbers, or floating-point representation. In addition, the display size can be switched between the 16-bit and 32-bit sizes. For the other types of devices, decimal numbers will be used.
- Device comments can be displayed together with the registered devices (see Sec. 5.5.13). To display device comments, click View and then Display Setting, or click the right button of the mouse in the device store/monitor window, and then click Display Setting.

New device storage

To store a new device, position the cursor at the desired position, and then open the device storage dialog box using one of the following methods.

Directly enter the device name using the keyboard.

When the cursor is at the desired position, press the  key.

Double-click the mouse button on the desired position.

Device storage dialog box

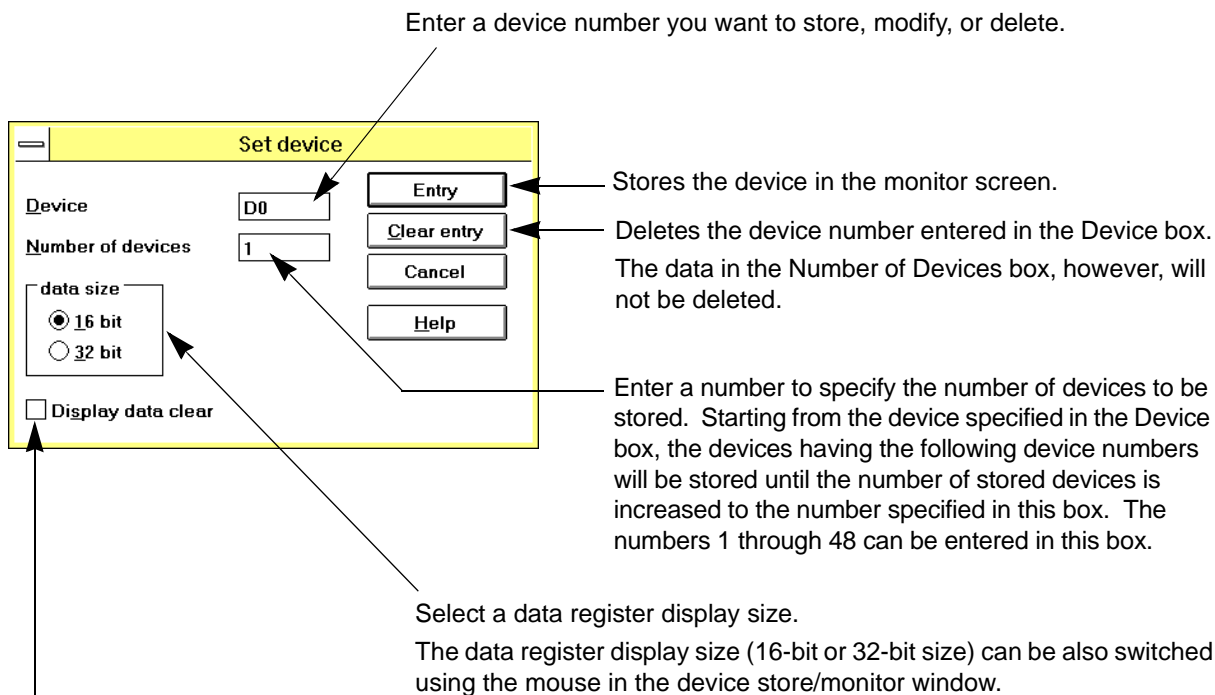

Click this button to store new devices after erasing all the devices currently stored.

Stored device change or delete

To change or delete a device once stored, position the cursor on the desired device, and then open the device storage dialog box using one of the three methods described above New device storage.

To delete a device, you can use another method. Position the cursor on the desired device, and then press the  key.

Other operations using the device store/monitor screen

The data register having character "L" will be displayed using the 32-bit size.

Double-click the current value of a data register. The display size of the data register will be switched between the 16-bit and 32-bit sizes.

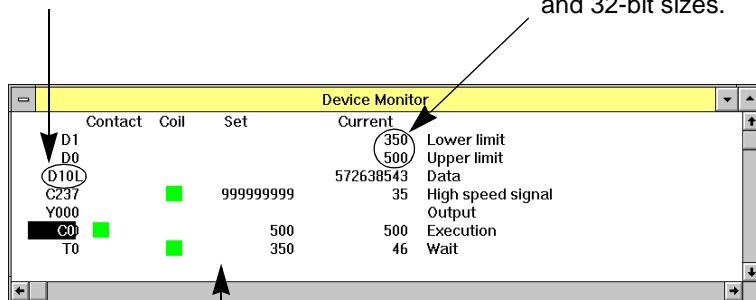

Click the right button of the mouse on an item displayed on the screen. The following shortcut menu will appear.

Force ON/OFF...	Forced setting or resetting of the corresponding bit device can be executed. In addition, the current value of the corresponding word device can be reset to zero. (See Sec. 5.7.6)
Change the current values...	The current value of the corresponding timer (T), counter (C), or data register can be modified. (See Sec. 5.7.7)
Display setting(D)...	The data register display size can be specified. In addition, whether the device comments should be displayed can be specified. (See Sec. 5.5.13)

Entering and monitoring devices using ladder diagram monitoring screen:

When the ladder diagram monitor window is open, the Entry Device Monitor (T,C,D) and Entry Device Monitor (Cursor) commands will be displayed in addition to the Entry Device Monitor command described before. The functions of these commands are described below:

- Function of Entry Device Monitor (T,C,D):
Started from the cursor position, up to 10 devices (data register : D, timer : T, counter : C) will be copied from the ladder diagram monitor window, and then pasted at the cursor position of the Entry Device Monitor screen.
- Function of Entry Device Monitor (Cursor):
The device inverted by the cursor will be copied from the ladder diagram monitor window, and then pasted at the cursor position of the Entry Device Monitor screen.
To execute this function, you can also use the shortcut key by clicking the right button of the mouse in the ladder diagram monitor window.

MEMO

5.7.5 Forced Y Output

OPN	L/V	L/M	I/V	S/V	S/M
	✓	✓	✓	✓	✓
—	C/V	R/V	D/L	D/M	SMP
				✓	

Use this command to perform forced on/off operation of the output relay (Y) in the programmable controller.

Enter a device number in this box.

Click the ON or OFF button to determine the type of device operation.

Click this button to execute the forced on/off operation.

Displays the operation history.

Execution conditions

Applicable device: Y

Programmable controller operation mode:

Run or stop mode

- This command is executed for only one operation cycle of the programmable controller. In the run mode, therefore, forced on/off will be valid for the self- hold circuits and SET/RST circuit.
- If the programmable controller is in the stop mode, or if the output unused in the program is specified, the forced output command will be held.
- This command can turn on the specified output relay even if no programs are stored in the programmable controller. This command, therefore, can be used for operation check, etc. at the completion of wiring.

5.7.6 Forced On/Off

OPN	L/V	L/M	I/V	S/V	S/M
	✓	✓	✓	✓	✓
—	C/V	R/V	D/L	D/M	SMP
				✓	

Use this command to perform forced on/off of the specified bit device in the programmable controller. In addition, use this command to reset the current value of the specified word device to zero.

Enter a device number.

Click the ON or OFF button to determine the type of device operation.

Click this button to execute the forced on/ off operation.

Displays the operation history.

Execution conditions

Applicable devices:

- X, Y, M, S, T, C (forced on/ off)
- T, C, D, Z, V (current value clear)

Programmable controller operation mode:

Run or stop mode

- This command is executed for only one operation cycle of the programmable controller. In the run mode, therefore, forced on/off will be valid for the self-hold circuits and SET/RST circuit, and current value clear will be valid for the T, C, D, Z, and V.
- If the programmable controller is in the stop mode, or if the output unused in the program is specified, the forced on/off command will be held.
- The current value of the specified file register cannot be reset to zero if the program memory in the programmable controller is the EPROM cassette. If the EEPROM cassette is used, set the protect switch to off before executing this command.

5.7.7 Change Current Values

OPN	L/V	L/M	I/V	S/V	S/M
	✓	✓	✓	✓	✓
—	C/V	R/V	D/L	D/M	SMP
				✓	

Use this command to modify the current value of the timer (T), counter (C), or data register (D) of the programmable controller.

Enter a device number.

Enter the value to be modified.
(For a detailed description, refer to the description below.)

Execution conditions

Applicable devices: T, C, D, Z, V
Programmable controller operation mode: Run or stop mode

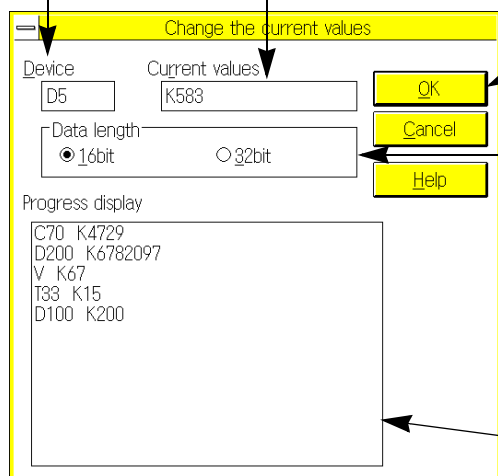

Click this button to execute modification of the current value.

Select data register type; 16 bits or 32 bits. Note that a 32-bit register consists of two 16-bit registers.
Example: When D0 is specified
If you specify 16 bits, the data of the D0 only will be modified.
If you specify 32 bits, the data of the D1 and D0 will be modified.
32 bits can be specified for the data registers (D) only.

Displays the operation history.

The current value of the specified file register cannot be modified if the program memory of the programmable controller is the EPROM cassette.

If the EEPROM cassette is used, set the protect switch to off before executing this command.

Current value setting range and applicable characters

Table:6.1

Device	Setting range and applicable characters
T	K0 to K32,767 (decimal data)
C0-C199	K0 to K32,767 (decimal data)
High Speed Counter	K-2,147,483,648 to K2,147,483,647 (decimal data)
D(16 bits)	K-32,768 to K32,767 (decimal data) H0000 to HFFFF (hexadecimal data) B0000000000000000 to B1111111111111111 (binary data) A (character string consisting of 8 ASCII characters or less)
D(32 bits)	K-2,147,483,648 to K2,147,483,647 (decimal data) H00000000-HFFFFFFF (hexadecimal data) A (character string consisting of 8 ASCII characters or less)
Z,V	K-32,768 to K32,767 (decimal data) H0000 to HFFFF (hexadecimal data)

Binary data entry : B****
 Decimal data entry : K****
 Hexadecimal data entry : H****
 ASCII data entry : A****



Enter an alphabetic character first to show the data type.

5.7.8 Change Setting Values

OPN	L/V	L/M	I/V	S/V	S/M
	✓	✓	✓		
—	C/V	R/V	D/L	D/M	SMP

Use this command to change the timer (T) and counter (C) setting values, constant (K, H) used as the operands of the instructions, or device numbers of the data registers (D) or index registers (V, Z).

Command execution conditions

Applicable devices : T and C (change in constant K or device number of indirectly specified data register)
 K and H in application instruction (constant change)
 D, V, Z in application instruction (change in device number)

Memory : Internal memory, RAM/ EEPROM (protect switch off) cassette

Programmable controller operation mode : Run or stop mode

- If there is difference in the step of the specified instruction between the personal computer and the programmable controller, writing data will be inhibited. Correct the step in the program, and then execute this command.
- No value can be changed if the new value specifies a different type or device. Specify the same type and do not change the total number of steps.
- When the ladder diagram edit window is in the monitoring mode, position the cursor on an output instruction, and then click Monitor/Test and then Change Setting Values, or double-click on the output instruction. The following dialog box will appear on the display.

Changing timer/counter setting value

The image displays three sequential screenshots of the 'Change the current values' dialog box, illustrating how to change application instructions and device settings.

- Example 1:** The dialog box shows 'Instruction: OUT' and 'Device: T0'. The constant 'K2' is selected in the device list, and 'K3' is entered in the adjacent input field. An arrow points to this input field with the text 'Change the constant.'.
- Example 2:** The dialog box shows 'Instruction: MOV'. The device list contains 'K2', 'K5', 'D0', and 'D0'. The first 'D0' is selected, and 'D0' is entered in the input field. An arrow points to this input field with the text 'Change the constant of the operand or device number of the data register.'
- Example 3:** The dialog box shows 'Instruction: FROM'. The device list contains 'K0', 'K5', 'K3M20', and 'K1'. The 'K3M20' entry is selected, and 'K3M20' is entered in the input field. An arrow points to this entry with the text 'This type of operand cannot be changed.'

Annotations for the dialog boxes:

- 'The instruction symbol set in this box cannot be changed.' (points to the Instruction field in Example 1)
- 'Changing application instruction: Example 1' (points to the Instruction field in Example 1)
- 'Changing application instruction: Example 2' (points to the Instruction field in Example 2)

5.7.9 Display change of monitor data(□□□)

OPN	L/V	L/M	I/V	S/V	S/M
		✓			
—	C/V	R/V	D/L	D/M	SMP

Use this command to change the current value display style for the ladder diagram monitor window. Each time you execute the command, the current value display style will be changed between decimal number display style and hexadecimal number display style (see Sec. 5.7.1).

Decimal numbers displayed in ladder diagram (initial values)

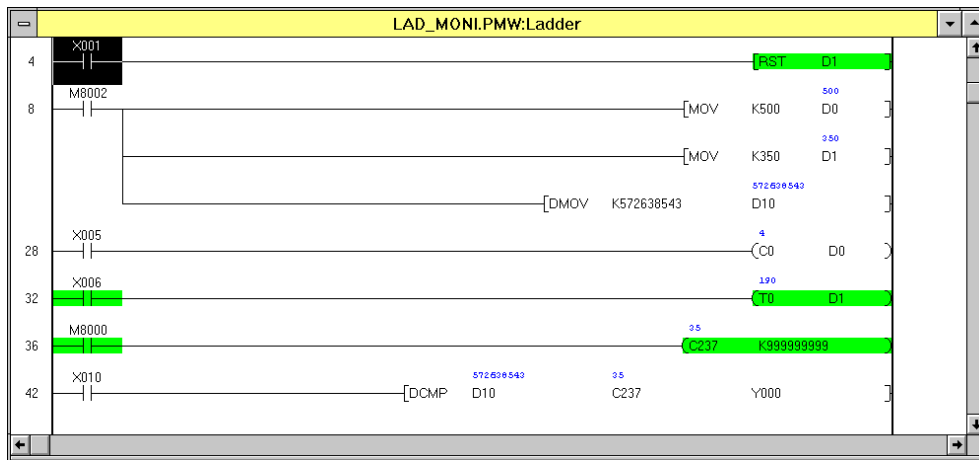

Hexadecimal numbers displayed in ladder diagram ("H" is added to the top of each value.)

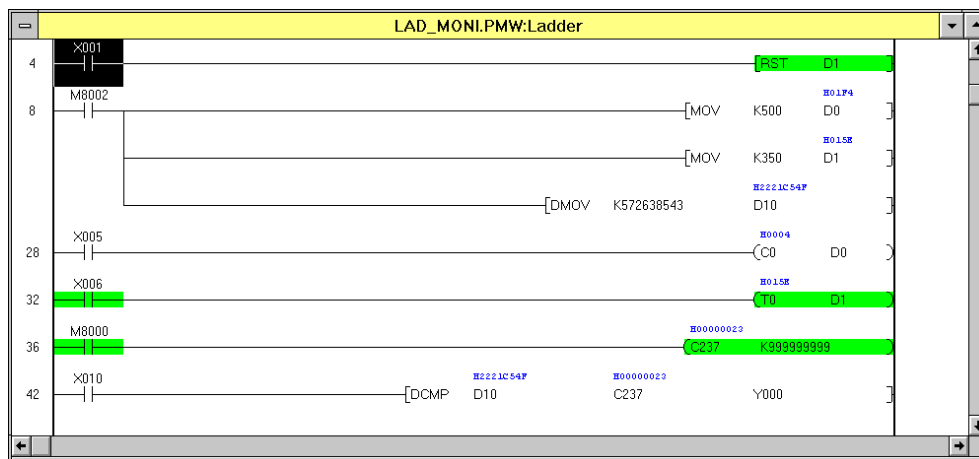

MEMO

5.8 Option Menu Functions

On the Option menu, there are various commands that are not directly related to the active window or current work. However, if you use a command related to the ROM writer, be sure to connect the units.



Two similar commands

The PLC menu and the Option menu have similar commands as described below

PLC → PLC Diagnostics

When a program is started with the programmable controller in the run mode, the programmable controller will check the program. The personal computer will display the detected error and operation status.

Option → Program Check

The personal computer checks the sequence programs stored in its own memory. If an error is detected, the personal computer will display the error portion.

PLC → PLC Keyword Current or Delete

This command can change or delete the keyword stored in the programmable controller.

Option → Keyword Setting

This command can change the keyword stored in the personal computer only. The keyword stored in the programmable controller will not be changed even if the controller is connected to the computer.

5.8.1 Program Check

OPN	L/V	L/M	I/V	S/V	S/M
	✓		✓	✓	
—	C/V	R/V	D/L	D/M	SMP
	✓	✓		✓	

Use this command to check the sequence programs stored in the personal computer for syntax errors, double coils, and circuit errors. If an error is detected, the error step will be displayed on the screen.

Check	Description
Syntax error	Checks the instruction codes and instruction formats. The check result will be displayed on the screen. If an error is detected, be sure to correct it.
Double coil	Checks the device symbols and device numbers in the program for double use of output instructions (OUT,SET,PLS, PLF,MC,RST) or labels (P,I). The check result will be displayed on the screen. If you use a double coil for some reasons, carefully check the operation.
Circuit	Checks the instructions in programs for circuit structural errors. The check result will be displayed on the screen. The error message displayed on the screen depends on the error type as described in the following table. If an error is detected, be sure to correct it.

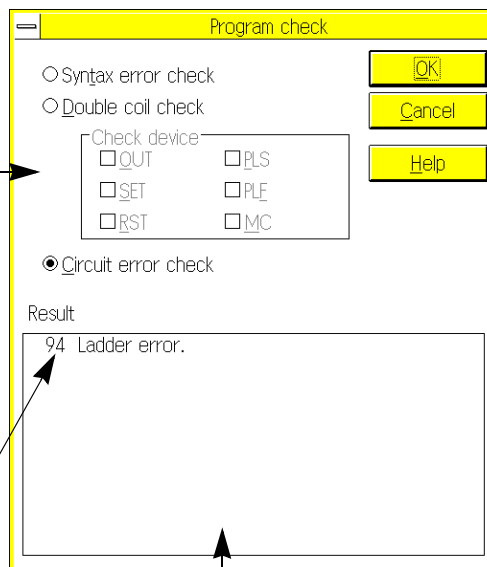

Step number Description

Error message	Description	Remedy
Ladder error	There is a circuit that cannot be converted. Examples: <ul style="list-style-type: none"> A wrong instruction is used as the first instruction of the circuit. The first instruction should be LD,LDI, or STL. Over-stacking Wraparound circuit 	Check the ladder diagram, and correct it.
Label error	Level instructions(P) are not used properly. Examples: CALL and P0 are used, but label P0 is not used.	Check the labels, and correct label instructions.
Step ladder Program error	The number of STL instructions is not appropriate, or the structure of the STL circuit is not appropriate. Examples: Nine consecutive STL instructions or more are set.	Check the STL instruction circuit, and correct the ladder diagram.
Subroutine Program error	The subroutine program is not created properly. Examples: <ul style="list-style-type: none"> The subroutine program is created at a wrong position. The subroutine is over-nested. An inhibited instruction is detected in the subroutine. 	Check the CALL and SRET instruction circuits, and correct the ladder diagram.
Interrupt Program error	The interrupt program is not created properly. Examples: <ul style="list-style-type: none"> The interrupt program is created at a wrong position. No IRET instruction is set. An inhibited instruction is detected in the interrupt program. 	Check the IRET,EI, and DI instruction circuits, and correct the ladder diagram.
FOR-NEXT Program error	The FOR-NEXT program is not created properly. Examples: <ul style="list-style-type: none"> Syntax error Over-nesting 	Check the loop instruction and correct the circuit.

5.8.2 Parameter Settings

OPN	L/V	L/M	I/V	S/V	S/M
	✓		✓	✓	
—	C/V	R/V	D/L	D/M	SMP
	✓	✓		✓	

Use this command to set the parameters for the programmable controller. The parameter-set items and parameter setting ranges depend on the type of the programmable controller as described below.

Parameter settings

Memory capacity
 2K 4K 8K 16K

File register Blocks(*500step)

Comment area Blocks(*500step)

Program 4000 steps

File register 0 words

Latch range

M	500	-	1023
S	500	-	999
C (16bit)	100	-	199
C (32bit)	220	-	255
D	200	-	511

Buttons: OK, Cancel, Default, Help

Annotations:
 - Enter a numeric value in the File Register box and the Comment Area box, respectively. The numeric value of 0 to 4 can be entered.
 - Click this button to reset the set values to the initial values as shown on the next page.

Set these values to change the devices in the power failure preventive range. The setting range depends on the programmable controller type. Refer to the instruction manual of your programmable controller. If the manual describes that the power failure preventive range should be fixed to the specified range, do not change the device numbers initially set.

The sequence programs are stored in the program memories of the programmable controller. These program memories can be classified into two types; internal memory incorporated in the programmable controller and optional memories installed whenever necessary. You can allocate the memory area for various purposes by setting parameters. To be concrete, for the programmable controller FX_{0N}, FX, FX_{2C} and FX_{2N} series, the memory area can be allocated to comments*¹, file registers, etc.

Setting range

Table:6.2

Unit : step		Memory type		
Model	Set data type	Initial memory	Optional memory cassette	
			FX-EEPROM-4	FX-ROM-8(C) FX-EPROM-8 FX-EEPROM-8(C)
FX ₀ FX _{0S}	Sequence program	0.8K		
	File register			
	Comment			
	Total	Fixed parameter		
FX _{0N}	Sequence program	0-2K	0-2K	0-2K (RAM cannot be used)
	File register	0-1.5K	0-1.5K	0-1.5K (RAM cannot be used)
	Comment	0-1.5K	0-1.5K	0-1.5K (RAM cannot be used)
	Total		2K	2K
FX FX _{2C}	Sequence program	0-2K	0-4K	0-16K
	File register	0-2K	0-2K	0-7K
	Comment	0-2K	0-4K	0-16K
	Total	2K	4K,maximum (2K is acceptable.)	8K,maximum (4K is acceptable.)

Table:6.3

Unit : Step		Memory type			
Model	Set data type	Internal memory	Optional memory cassette		
			FX _{2N} PC: FX-EEPROM-4 FX _{2NC} PC: FX _{2NC} -EEPROM-4C	FX _{2N} PC: FX-EEPROM-8	FX _{2N} PC: FX-EEPROM-16 FX-EPROM-8 FX-RAM-8 FX _{2NC} PC: FX _{2NC} -EEPROM-16 FX _{2NC} -EEPROM16C
FX _{2N} FX _{2NC}	Sequence program	0-8K	0-4K	0-8K	0-16K
	File register	0-7K	0-4K	0-7K	0-7K
	Comment	0-8K	0-4K	0-8K	0-16K
	Total	8K,maximum (2K/4K mode is acceptable.)	4K,maximum (2K mode is acceptable.)	8K,maximum (2K/4K mode is acceptable.)	16K,maximum (2K/4K/8K mode is acceptable.)

Initial values of parameters

Table: 6.4

Item		Remedy FX(FX2C,FX0N,FX0S,FX0)
Memory capacity	Program storage capacity	2000 steps
	Comment storage capacity	0
	File register capacity	0
Latch range *2	Auxiliary relay [M]	500-1023
	State [S]	500-999
	Counter [C](16)	100-199
	Counter [C](32)	220-255
	Data register [D]	200-511
Program title		Not stored
Keyword		Not stored

FX0, FX0S series : You can store only the keyword.

Do not change the initial values of the memory capacity, latch range, and program title.

FX0N series : You can change the initial values of the comment storage capacity, file register capacity, program title, and keyword.

Do not change the initial values of the program storage capacity and latch range.

FX, FX2C series : You can change any the parameters.

Table: 6.5

Item		Remedy FX2N
Memory capacity	Program storage capacity	8000 steps
	Comment storage capacity	0
	File register capacity	0
Latch range *2	Auxiliary relay [M]	500-1023
	State [S]	500-999
	Counter [C](16)	100-199
	Counter [C](32)	220-255
	Data register [D]	200-511
Program title		Not stored
Keyword		Not stored
Battery-less mode		OFF
RUN terminal input setting		Not set
RUN terminal input number		Not stored

- Click Save As to set the program title.
- Click Option and then Keyword Setting to set the keyword.
- Click Option and then PLC's Mode Setting to set the battery-less mode and RUN terminal input.

*2:If the set range of an item is specified as the fixed range for the reason of power failure prevention, do not change the device numbers initially set.

5.8.3 Keyword Setting

OPN	L/V	L/M	I/V	S/V	S/M
	✓		✓	✓	
—	C/V	R/V	D/L	D/M	SMP
	✓	✓		✓	

Use this command to store, change, or delete the keyword for the program stored in the personal computer. The set keyword will not affect the keyword stored in the programmable controller.

For a detailed description of the keyword, refer to Sec.5.6.5 "PLC Keyword Current or delete".

5.8.4 PLC's Mode Setting

OPN	L/V	L/M	I/V	S/V	S/M
	✓	✓	✓	✓	✓
—	C/V	R/V	D/L	D/M	SMP
	✓	✓	✓	✓	

Use this command to set the battery-less mode, modem, and RUN terminal. Use parameters of the programmable controller FX2N series for setting.

Click ON button to remove the memory backup battery from the FX2N series for operation.

Enter data in this box to use a modem.
None, User entry mode, AIWA (PV-AF288), OMRON (ME3314B)

Enter a device number in this box to specify the device to which the external run/stop signal is input.

Click the Yes button to input the external run/stop signal to the programmable controller FX2N series.

X0 to X17 (X0 to X7 for FX2N-16M series)

5.8.5 Serial Setting (Parameter)

OPN	L/V	L/M	I/V	S/V	S/M
	✓	✓	✓	✓	✓
	C/V	R/V	D/L	D/M	SMP
	✓	✓		✓	

The serial communication setting data will be stored as the parameter of the programmable controller FX2N series, and overwritten in the special data registers D8120 (communication format), D8121 (station number setting), and D8129 (overtime judgment value).

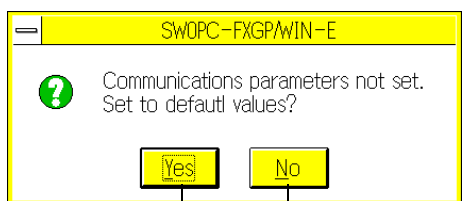

If no parameters are set, the values shown below will be loaded as the initial values, and the dialog box will appear on the display to ask whether the initial values should be changed.

If initial values are set and stored, they will appear in the window shown below.

Click this button not to set the initial values.

- RS instruction , Link
- Z, 8
- None, Odd, Even
- 1, 2
- Click this button to erase the set parameters. (Each register value will be reset to zero.)
- 19200, 9600, 4800, 2400, 1200, 600, 300
- OFF, ON
- None, H/W mode
- Normal/RS-485, Modem/RS-232C
- No, Yes
- 00H - 0FH (0)
- 1 - 255 (1)

_ : Initial condition

5.8.6 Printer Title

OPN	L/V	L/M	I/V	S/V	S/M
	✓		✓	✓	
—	C/V	R/V	D/L	D/M	SMP
	✓	✓		✓	

Use this command to set the title to be printed on a document.

Up to 12 characters can be changed.

Enter a title in this box.

Example: Title change

Document printed

```

1.Title Test Program No.1
-----
2.Machine Type:KAZ-HA-1M
-----
3.Controller FX2N-64MR
-----

4.User ABCD CORPORATION           7.Maker August 1997
-----
5.Version A                       8.Date C*****
-----
6.Designer B*****              9.Approver D*****
-----
    
```

5.8.7 Device range Setting

OPN	L/V	L/M	I/V	S/V	S/M
	✓		✓	✓	
—	C/V	R/V	D/L	D/M	SMP
	✓	✓		✓	

Use this command to set the device ranges for programming. Device ranges are specified for the programmable controller, however you can set different device ranges using this command.

Device range setting

PLC type: FX2N

X	000	-	377	C	0	-	199	OK
Y	000	-	377	C(200-)	200	-	255	Default
M	0	-	1535	D		-		Cancel
S	0	-	999	D(8000-)		-		Help
T	0	-	199	D(1000-)		-		
T(200-)	200	-	255					

After setting device ranges, you cannot enter any out-of-range devices even if the programmable controller stores the device numbers.

This function is valid when you enter or check programs.

5.8.8 Comment Move

OPN	L/V	L/M	I/V	S/V	S/M
	✓		✓	✓	
—	C/V	R/V	D/L	D/M	SMP
	✓	✓		✓	

Use this command to convert the DOS type comments stored in the program area to the FXGP/WIN-E type comments. The comments converted can be stored in files (*.COW) as the comments to be controlled by the peripheral units. In addition, the comments converted can be displayed on the screen and edited.

For a detailed description of the DOS type comments controlled by the FXGP/WIN-E, refer to Sec.1.4.

Flowchart for comment conversion

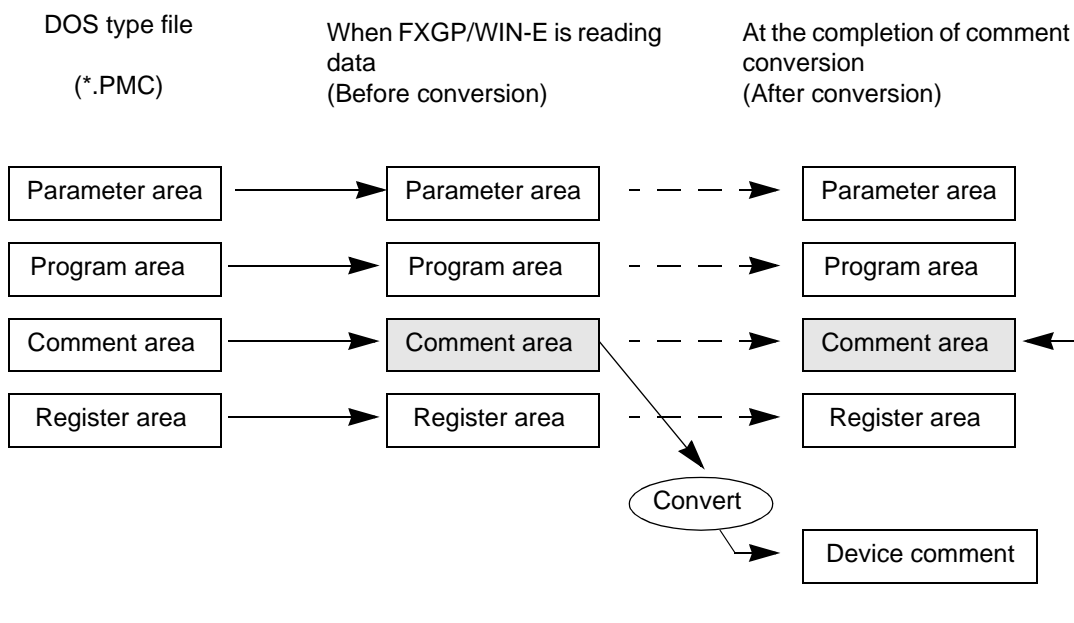

The meanings of the comments stored in the comment area will not be changed or erased. After transferred to the programmable controller, the parameter-set comments still exist in the parameter area.

- If a device has a device comment already stored, the new comment will be overwritten on the previous comment when comment conversion is executed.
- After comment conversion, the comments stored in the program area may be unnecessary. If they are unnecessary, click Parameter Setting and then Comment Area. After that, set the number of blocks to "0" to delete the comments from the program area.
- After conversion, the device comments already converted will be regarded as comments not to be written in the programmable controller. To write device comments in the programmable controller, specify the range while referring to Sec. 5.3.9.

5.8.9 PLC Type Change

Use this command to change the programmable controller type currently set in the sequence program to the upper model.

The PLC Type Change window will appear on the display. In this window, the models applicable to the program currently edited will be displayed. Select a model. Note that you cannot select the model if it is dimmed.

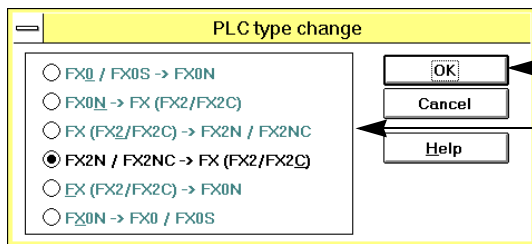

Click this button to change the programmable controller type.

Select a model to change the current model to the selected mode.



Change from an upper-level model to a lower-level model

- The PC model confirmation item exclusively can be changed by the model change function. Even if an element No. or application instruction to which the change destination model does not correspond is included in the change destination program, the contents of the program are not corrected.
Correct such an element No. or application instruction to which the change destination model does not correspond before or after changing the model. (If an uncorrected program is transferred to the PC, a program error will occur.)
- If a set item to which the change destination model does not correspond is included in the parameter setting of the change destination program, the message "parameter error" will be displayed and the change will be aborted.
In this case, return the item to which the change model does not correspond in the parameter setting of the change destination program to the initial value, then execute model change again.

5.8.10 Preferences

OPN	L/V	L/M	I/V	S/V	S/M
	✓		✓		
—	C/V	R/V	D/L	D/M	SMP
	✓	✓		✓	

Use this command to set the operation environment of the FXGP/WIN-E.

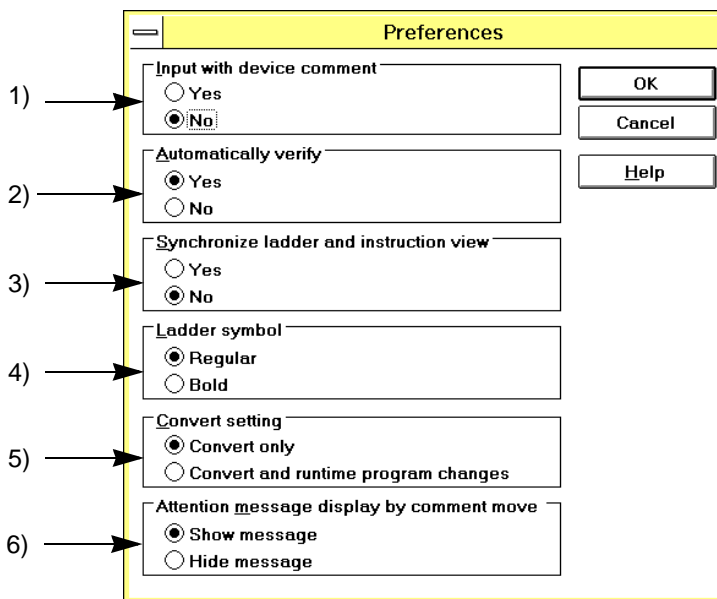

- 1) Click the Yes button in the Input with Device Comment box.
 After that, if you enter a circuit symbol in the ladder diagram edit window to create or change a program, the device comment entry dialog box will appear on the display.
 If you click No button in the Input with Device Comment box, the device comment entry dialog box will not appear automatically as described above.
 In this case, use the Edit command or comment window to enter device comments. (see Sec.5.2.13)
- 2) Click the Yes button in the Automatically Verify box.
 After that, if you write programs in the programmable controller, the programs will be automatically collated.
 If you click the No button, programs can be written in the programmable controller, but no collation will be performed. (see Sec.5.6.1)
- 3) Click the Yes button in the Synchronize Ladder and Instruction View box.
 After that, if you switch the window between the ladder edit window and the list edit window, the cursor-positioned step will be displayed at the top of the newlydisplayed window.
 If you click the No button, the steps displayed in the respective windows will not be synchronized as described above. If you want to synchronize the steps, select Refresh from the Window menu or tool bar.
- 4) Select the line type (Regular or Bold) for the circuit display. The line type selected here is valid for display of Ladder view and printout of circuit diagrams. (see Sec.5.9)
- 5) If you select "Convert and runtime program changes", write in the run status described in "5.6.6 Runtime Program Changes" will be executed after CNV (F4) or "Tools → Convert" is executed.
 Select "Convert only" if you do not want to execute write in the run status after a circuit has been changed or if a PC is not connected. (see Sec.5.3.7)
- 6) If the file you opened has comments in the program, a confirmation message will appear and ask you whether the comments should be transferred to the device comment area. If you do not need such confirmation message, click the Yes button in the Hide Message box. The comments will be overwritten in the device comment area without confirmation. (see Sec. 5.1.2)

5.8.11 EPROM Transfer

OPN	L/V	L/M	I/V	S/V	S/M
	✓		✓	✓	
—	C/V	R/V	D/L	D/M	SMP
	✓	✓		✓	

Use this command to read, write, or collate program data using the optional EPROM type memory cassette or EPROM IC installed on the ROM writer. For this data transfer, connect the personal computer to the general-purpose writer using the RS-232C cable, and install the optional EPROM type memory cassette or EPROM IC on the ROM writer.

- Connection method : Refer to Sec.1.2.3 "System configuration".
- ROM writer : PECKER-11 manufactured by AVAL, or the equivalent ROM writer (Intel hex used as data transfer format)
- Applicable memory cassette : FX-EPROM-8 (Note that ROM adapter FX-ROM-SOC-1 (optional) is needed.)
- Data transfer : Program memory clear (parameters, programs, comments, file registers)

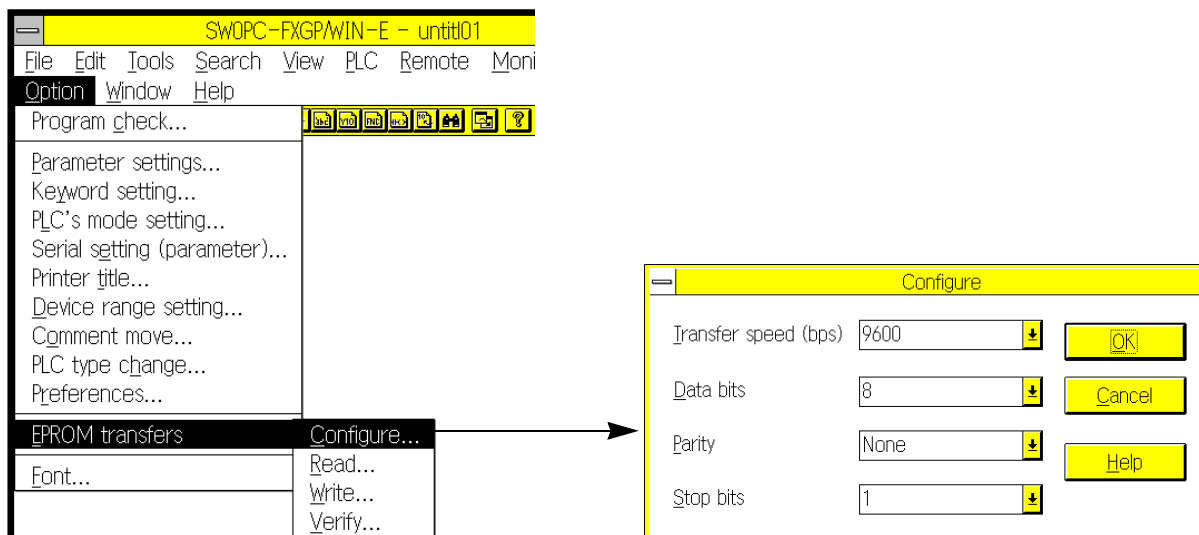

Read

Reads out data from the ROM writer, and stores the data in the memory of the personal computer. To read data, select the programmable controller model name, and then execute reading. If the keyword is stored in the ROM, keyword entry dialog box will appear on the display. Enter a right keyword.

Write

Transfers the data stored in the program memory area of the personal computer to the memory of the ROM writer.

Verify

Collates the data stored in the memory of the personal computer with the data stored in the memory of the ROM writer.

- Baud rate: 9600, 4800, 2400, 1200, 900, 600, 300
- Data length: 8, 7
- Parity check: No parity check, odd parity check, even parity check
- Stop bit: 1, 2

Set the above items to determine the communication conditions. Note that the set communication conditions should be the same as those of the ROM writer.

To transfer the data from the ROM writer, set the transfer format to Intel hex.



Regarding ROM writer

Generally, the ROM writer reads out the data from the ROM and stores the data in the memory of the ROM writer to transfer the data. In addition, the data transferred from the personal computer to the memory of the ROM writer should be written in the EPROM.

For a detailed description of the ROM writer, refer to the instruction manual of the ROM writer.

5.8.12 Font

OPN	L/V	L/M	I/V	S/V	S/M
	✓	✓	✓	✓	✓
—	C/V	R/V	D/L	D/M	SMP
	✓	✓		✓	✓

Use this command to set the font for the FXGP/WIN-E.

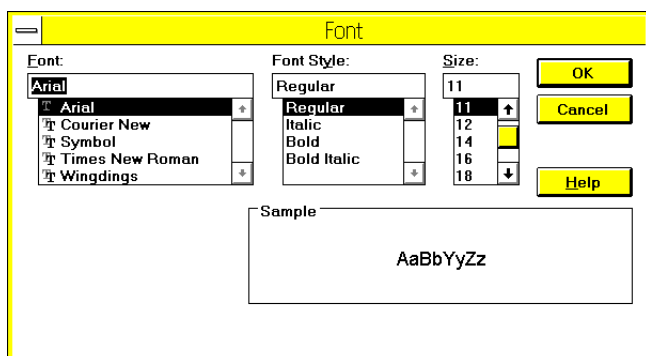

Change the font size to change the size of the symbols displayed in the ladder diagram or the characters displayed in the instruction list.

Also use the Zoom (Z) command to change the size of the displayed symbols and characters.

Initial setting (Recommendation)

- Font: MS sans serif
- Font Style: Bold
- Size: 8

5.9 Window Menu Functions

OPN	L/V	L/M	I/V	S/V	S/M
	✓	✓	✓	✓	✓
—	C/V	R/V	D/L	D/M	SMP
	✓	✓	✓	✓	✓

Use the commands on the Window menu to select the window display method.

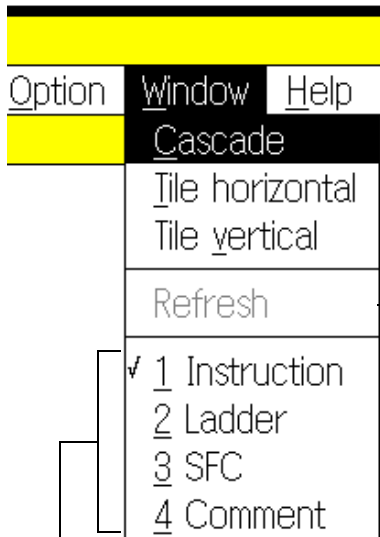

The windows currently open are shown on the pull-down menu. Click the mouse button on a window name to select the window.

You can synchronize the program steps between the ladder diagram edit window and the list edit position using the cursor as the reference position (see Sec.5.8.10).

Example: Overlapped windows

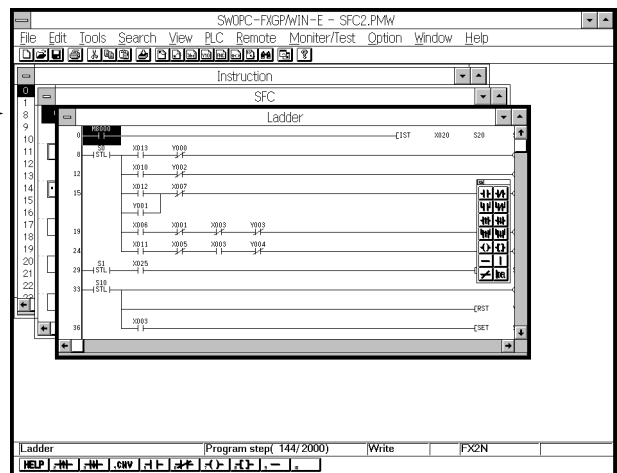

Example: Windows placed side by side or up and down

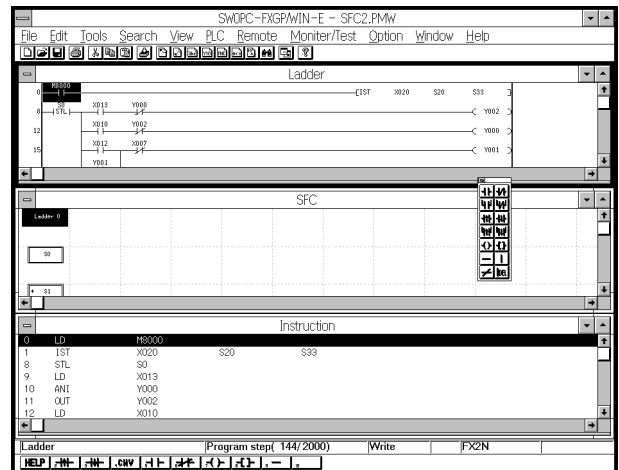

5.10 Help Menu Functions

OPN	L/V	L/M	I/V	S/V	S/M
✓	✓	✓	✓	✓	✓
—	C/V	R/V	D/L	D/M	SMP
	✓	✓	✓	✓	✓

On the Help screen, how to operate the FXGP/WIN-E and how to use various functions will be described.

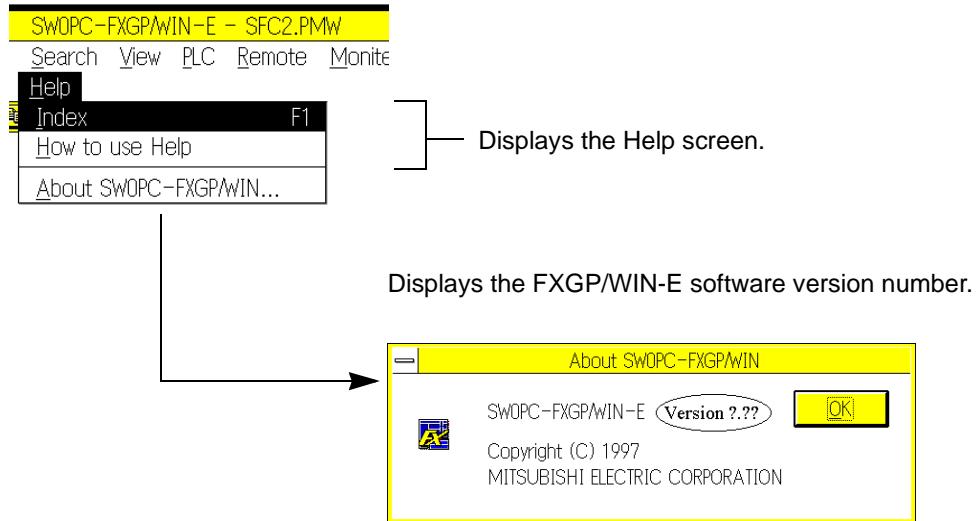

MEMO

MEMO

MEMO

1	Introduction
2	Installing FXGP/WIN-E
3	Main Operation
4	Work Windows and their Functions
5	Menu Bar Commands and their Functions
6	Creating Ladder and Instruction Programs
7	Creating SFC Programs
8	Remote Maintenance Using Telephone Line
	Appendix

6. Creating Ladder and Instruction Programs

This section describes main operations necessary for creating or editing ladder programs or instruction programs and the main items necessary for programming.

6.1 Use of Programming Window

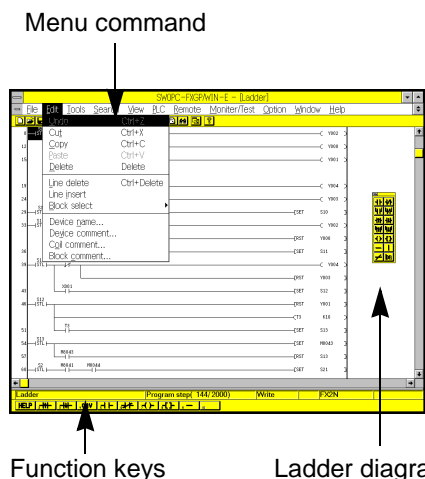

- To create a ladder program, open the ladder diagram edit window. Click File and then New or click View and then Ladder View to open the ladder diagram edit window. To create or edit ladder diagrams, you can use the symbols allocated to the function keys. You can also use the Tools command on the Edit menu.

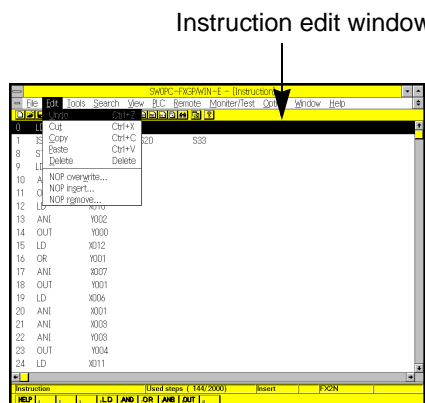

- To create an instruction program, open the instruction edit window. Click File and then New or click View and the Instruction View to open the instruction edit window. To create or edit instruction lists, you can use the symbols allocated to the function keys. You can also use the commands on the menu bar.

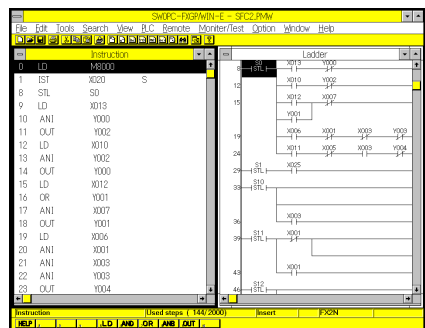

- The main difference between the ladder diagram edit window and the instruction edit window is that the instruction entered in the instruction list will be valid, but the instructions entered in the ladder diagram is not valid until it is converted and set in the instruction list. You can create or edit a program while comparing both windows as shown in the figure. For the above described reasons, the same program will be shown in both windows at the completion of circuit conversion, or at the completion of creation of 1 circuit block. You can synchronize the program steps between both windows. Click Option and then Preferences and then select the synchronous mode. Or click Window and then Refresh.

6.2 Creating Ladder Programs



6.2.1 Main operations necessary for entering circuit symbols

Use this command to enter circuit symbols. There are two symbol entry methods. One is to use the symbols allocated to the function keys of the ladder diagram edit window, and the other is to use the Tools command on the menu. For both methods, enter data in the dialog box shown on the screen.

Entering contact symbol (method 1)

Using instruction entry dialog box:

Entering a-contact symbol (LD, AND, OR)



-  (F5 or tool pallet)
- Tools → Contact → 
 - To use this symbol as the OR, enter additional vertical lines.

Directly entering OR symbol

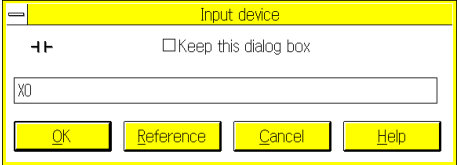
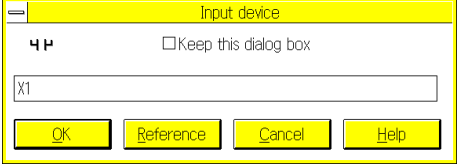
-  (Shift + F5 or tool pallet)





Entering a-contact symbol (LDI, AND, ORI)

-  (F6 or tool pallet)
- Tools → Contact → 
 - To use this symbol as the ORI, enter additional vertical lines.

Directly entering ORI symbol

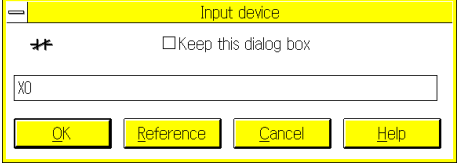
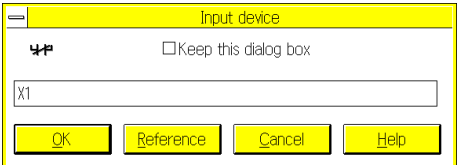
-  (Shift + F5 or tool pallet)





Applicable devices:

- | | | |
|------------------|---------------------|-------------|
| X (input relay) | M (auxiliary relay) | T (timer) |
| Y (output relay) | S (state) | C (counter) |

Data entry method 1

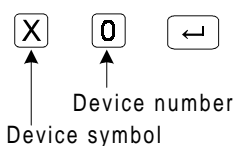
Entering device number



Data entry method 2

Entering device name

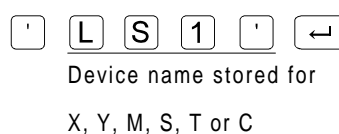

Entering contact symbol (method 2)

Using instruction entry dialog box:

Entering rise detection symbol (LDP, ANDP, ORP)

- -|↑|- (F2 or tool pallet)
- Tools → Contact → -|P|-
To use this symbol as the ORP, enter additional vertical lines.

Directly entering ORP symbol

- (Shift + F2 or tool pallet)

For LDP, ANDP, and ORP instructions

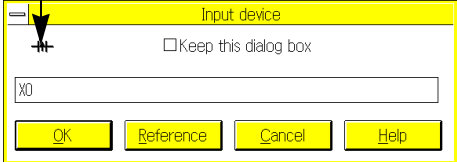

For ORP instruction only

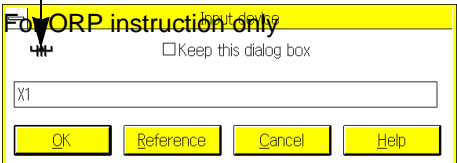

Entering fall detection symbol (LDF, ANDF, ORF)

- -|↓|- (F3 or tool pallet)
- Tools → Contact → -|F|-
To use this symbol as the ORF, enter additional vertical lines.

Directly entering ORF symbol

- (Shift + F3 or tool pallet)

For LDF, ANDF, and ORF Instructions

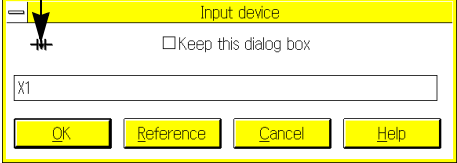

For ORF Instruction only

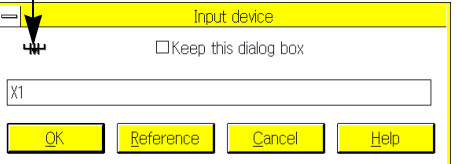

Applicable devices:

- | | | |
|------------------|---------------------|-------------|
| X (input relay) | M (auxiliary relay) | T (timer) |
| Y (output relay) | S (state) | C (counter) |

Data entry method 1

Entering device number

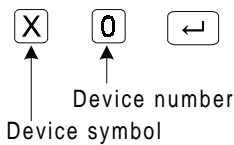

Data entry method 2

Entering device name

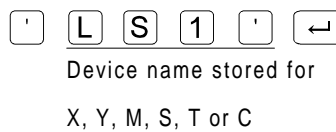

Entering coil symbol

Using instruction entry dialog box:

- (-)- (F7 or tool pallet)
- Tools →Coil

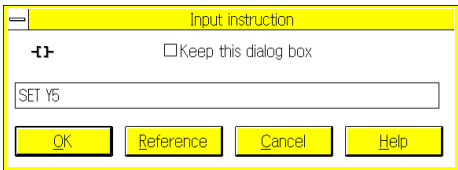

Applicable devices:

Y (output relay) S (state) T (timer)
 M (auxiliary relay) C (counter)

Data entry method 1: Entering device number:

Y 0 ↵
(Entering OUT Y0)

↑ ↑

Device symbol (Y, M or S) Device number

T 0 SPACE K 1 ↵
(Entering OUT T0 K1)

↑ ↑

Device symbol (T or C) Device number Specifying constant using decimal number

T 0 SPACE D 0 ↵
(Entering OUT T0 D0)

↑ ↑

Device symbol (T or C) Device number Indirectly specifying constant using data register

Data entry method 2: Entering device name:

' R Y 1 ' ↵
(Entering OUT RY1)

Device name stored for Y, M or S

' W A I T 1 ' SPACE K 1 ↵
(Entering OUT WAIT1 K1)

Device name stored for T or C Specifying constant using decimal number

' W A I T 1 ' SPACE ' 1 0 S ' ↵
(Entering OUT WAIT1 10S)

Device name stored for T or C Device name stored for indirectly specified data register

Data entry method 3: Entering both device number and device name:

T 0 SPACE ' 1 0 S ' ↵
(Entering OUT T0 10S)

↑ ↑

Device symbol (T or C) Device name stored for indirectly specified data register

Device number

' W A I T 1 ' SPACE D 0 ↵
(Entering OUT WAIT1 D0)

Device name stored for T or C Indirectly specifying constant using data register

Entering special coil symbol

Using instruction entry dialog box:

- -[-] (F8 or tool pallet)
- Tools → Function

Input instruction

← Keep this dialog box

SET Y5

OK
Reference
Cancel
Help

Applicable instructions:

SET/RST	MC/MCR	END
PLS/PLF	STL/RET	

Data entry method: Entering special coil by specifying device number:

<p style="text-align: center;"> S E T SPACE M O ← </p> <p style="text-align: center;">SET/RST instruction</p>	<p>↑ ↑</p> <p>Device symbol Device number</p> <p>SET: Y, M, S RST: Y, M, S, T, C, D</p>	(Entering SET M0)
<p style="text-align: center;"> P L S SPACE M O ← </p> <p style="text-align: center;">PLS/PLF instruction</p>	<p>↑ ↑</p> <p>Device symbol Y, M:</p>	(Entering PLS M0)
<p style="text-align: center;"> M C SPACE N O SPACE M O ← </p> <p style="text-align: center;">MC instruction</p>	<p>↑ ↑</p> <p>Nesting level Device number</p> <p>Device symbol Y, M:</p>	(Entering MC N0 M0)
<p style="text-align: center;"> M C R SPACE N O </p> <p style="text-align: center;">MCR instruction</p>	<p>↑ ↑</p> <p>Nesting level</p>	(Entering MCR N0)
<p style="text-align: center;"> S T L SPACE S O ← </p> <p style="text-align: center;">STL instruction</p>	<p>↑ ↑</p> <p>Device numbers Device number</p>	(Entering STL S0)
<p style="text-align: center;"> R E T ← </p> <p style="text-align: center;">RET/END instruction</p>		(Entering RET)

Regarding the above data entry method, you can enter device names in place of the device symbols. For the device name entry method, refer to Entering contact symbol or Entering coil symbol described on the previous pages.

Entering application instruction

Using instruction entry dialog box:

-  (F8 or tool pallet)
- Tools → Function

Input instruction

Keep this dialog box

MOV K200 D0

OK
Reference
Cancel
Help

Data entry method 1: Entering application instruction by specifying instruction word:

M **O** **V** **SPACE** **K** **1** **0** **SPACE** **D** **0** 16-bit MOV instruction

Instruction word Operand 1 Operand 2

M **O** **V** **P** **SPACE** **K** **1** **0** **SPACE** **D** **0** 16-bit MOV instruction of pulse execution type

Instruction word ↑ Operand 1 Operand 2

Specifies the pulse execution type.

D **M** **O** **V** **SPACE** **K** **4** **0** **0** **0** **0** **SPACE** **D** **0** 32-bit MOV instruction

↑ Instruction word Operand 1 Operand 2

Specifies the 32-bit type.

D **M** **O** **V** **P** **SPACE** **K** **4** **0** **0** **0** **0** **SPACE** **D** **0** 32-bit MOV instruction of pulse execution type

↑ Instruction word ↑ Operand 1 Operand 2

Specifies the 32-bit type. Specifies the pulse execution type.

Data entry method 1: Entering application instruction by specifying FNC.number:

F **N** **C** **1** **2** **SPACE** **K** **1** **0** **SPACE** **D** **0** 16-bit MOV instruction

FNC. No. Operand 1 Operand 2

F **N** **C** **1** **2** **P** **SPACE** **K** **1** **0** **SPACE** **D** **0** 16-bit MOV instruction of pulse execution type

FNC. No. ↑ Operand 1 Operand 2

Specifies the pulse execution type.

F **N** **C** **D** **1** **2** **SPACE** **K** **4** **0** **0** **0** **0** **SPACE** **D** **0** 32-bit MOV instruction

↑ FNC. No. Operand 1 Operand 2

Specifies the 32-bit type.

F **N** **C** **D** **1** **2** **P** **SPACE** **K** **4** **0** **0** **0** **0** **SPACE** **D** **0** 32-bit MOV instruction of pulse execution type

↑ FNC. No. ↑ Operand 1 Operand 2

Specifies the 32-bit type. Specifies the pulse execution type.

Regarding the above data entry method, you can enter device names in place of the operands. For the device name entry method, refer to Entering contact symbol or Entering coil symbol described on the previous pages.



Entering instruction using Reference command

Click Reference in the contact, coil, special coil, or application instruction entry dialog box. You can select device names or application instructions from the list displayed on the screen. For a detailed description of operation in each dialog box, refer to Sec.5.3 "Tools".

You can enter an instruction in this box by selecting it from the list. Or you can directly enter an instruction word or FNC number in this box.
 Example: ZCP, DZCP, FNC11, FNCD11P

Select an instruction.

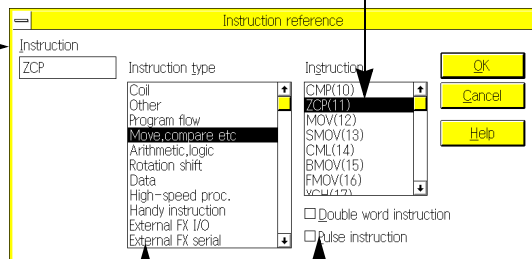

Displays the instruction types.

If you want to use the specified instruction as the 32-bit or pulse execution type, click the mouse button in this box to enter the check mark.

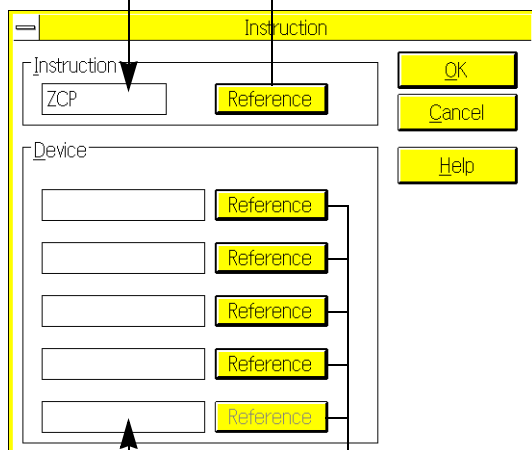

The operand necessary for the specified instruction is described in this box, and the system will enter the data entry waiting mode.

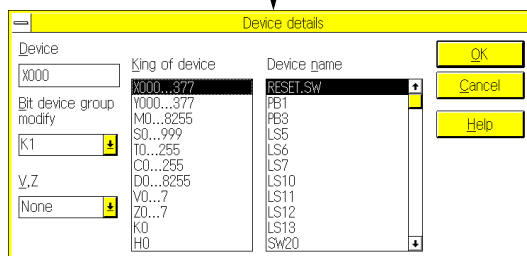

You can specify the operand or device name.

Entering INV instruction

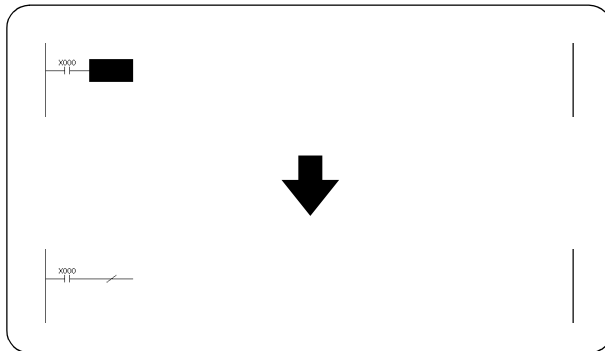

To enter INV instruction to the ladder diagram, perform one of the following operations:

Operation	Description of motion
\uparrow Shift + F7 (- / -)	The INV instruction will be entered.
Tool pallet (- / -)	
[Tools] → [Wire] → [- / - (!)]	
I N V	

Entering horizontal line:

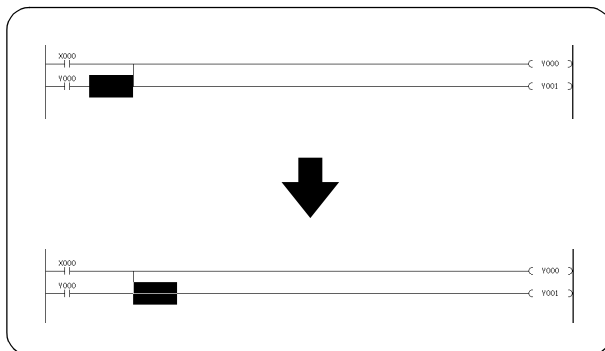

To enter a horizontal line in the ladder diagram, perform one of the following operations:

Operation	Description of motion
F9 (-)	A horizontal line will be entered.
⊖	
Tool pallet (-)	
[Tools] → [Wire] → [-]	
A N B	The specified number of horizontal lines will be entered. (The number is specified by K.)
A N B K 1 ~ K 1 1	
Alt + → / ←	A continuous line of desired length can be drawn rightward or leftward.

Entering vertical line

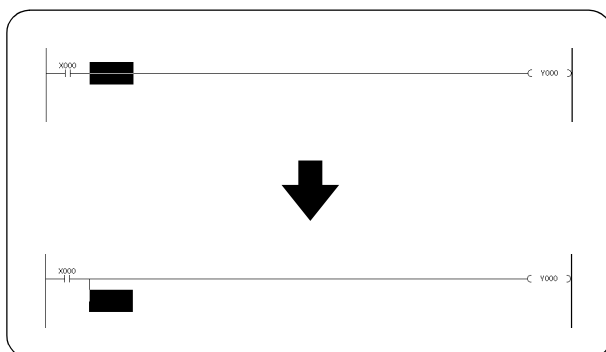

To enter a vertical line in the ladder diagram, perform one of the following operations:

Operation	Description of motion
(↑Shift) + (F9) ()	A vertical line will be entered.
(↑Shift) + ()	
Tool pallet ()	
[Tools] → [Wire] → []	
(O) (R) (B)	
(O) (R) (B) (K) (1) ~ (K) (4) (9)	The specified number of vertical lines will be entered. (The number is specified by K.)
(Alt) + (↑) / (↓)	A continuous line of desired length can be drawn upward or downward.

Entering special instruction

Entering label P or I:

Position the cursor on the left side of the bus in the ladder diagram, and then press the P or I key. The label entry dialog box will appear on the display.

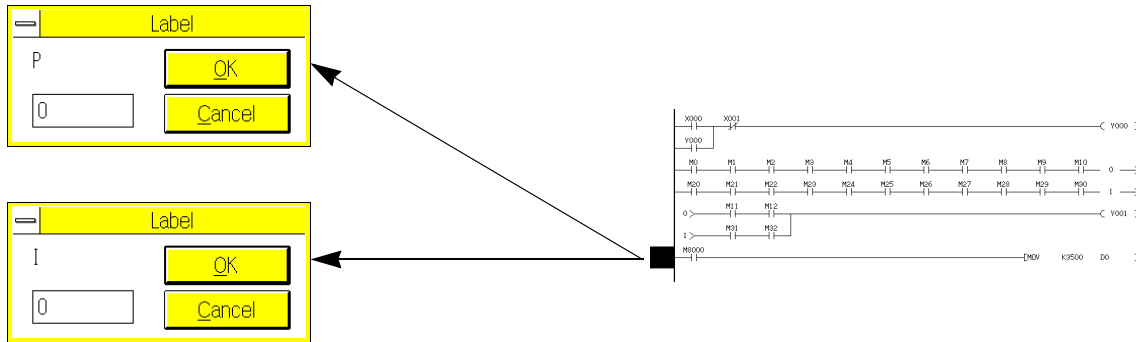

Manual setting of circuit turning point:

Double-click the turning point number, or position the cursor on the turning point, and then press the K key. The Turning Point dialog box will appear on the display. Using this dialog box, you can change the turning point number automatically sampled.

The turning point number can be set in the range of 0 to 255.

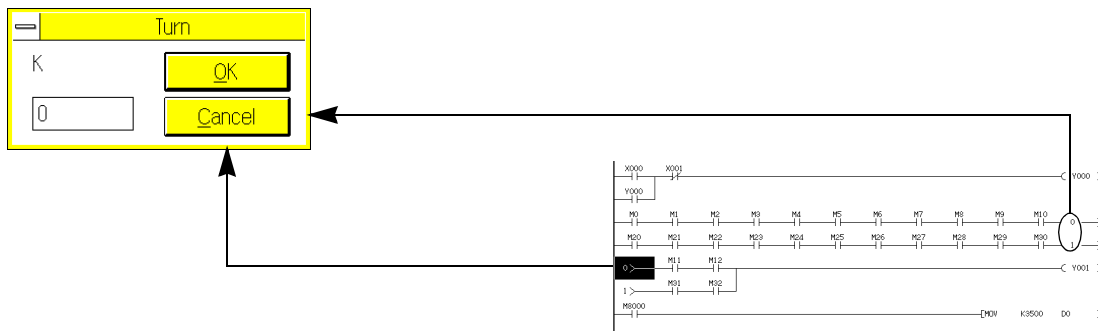

MEMO

6.2.2 Instruction type circuit entry

In the ladder diagram edit window, you can enter circuit symbols using the methods described before. In addition, you can also enter instructions, such as AND and OUT, to edit ladder diagrams (Instruction type entry method).

Applicable instructions:

LD, LDI, LDP, LDF	PLS, PLF
AND, ANI, ANDP, ANDF	STL, RET, MC, MCR
OR, ORI, ORP, ORF	INV, ANB, ORB, P, I
OUT, SET, RST	Application instructions (FNC numbers or instruction words)

Data entry method:

Refer to the data entry methods described in Sec.6.3.1.

Ladder diagram drawing concept and symbol conversion:

All the instruction words entered will be converted into circuit symbols, and then displayed on the screen. For this reason, you can use this method together with the circuit symbol entry method described before.

Instruction word / Keyboard operation	Symbol to be drawn on ladder diagram
LD,AND	
LDI,ANI	
LDP,ANDP	
LDF,ANDF	
OR/ORI	
ORP/ORF	
INV	
ANB	—
	(1 horizontal line)
ANB K1 to K11	(1 to 11 continuous horizontal lines)
+ /	(Continuous horizontal line of desired length)
ORB	
+	(1 vertical line)
ORB K1 to K49	(1 to 49 continuous vertical lines)
+ /	(Continuous vertical line of desired length)

Instruction word			Symbol drawn in ladder diagram
OUT	Device symbol	Device number	—————(Y000)———
OUT	Device symbol	Setting Values	—————(T3 K20)———
SET	Device symbol	Device number	—————[SET M3]———
RST	Device symbol	Device number	—————[RST M3]———
PLS	Device symbol	Device number	—————[PLS M3]———
PLF	Device symbol	Device number	—————[PLF M3]———
STL S	Device number		
RET			—————[RET]———
MC N* Y/M	Device number		—————[MC N0 M2]———
MCR N*			—————[MCR N0]———
p*			P2 ———
I*			I001 ———
END			—————[END]———

Regarding the application instructions other than the above, directly enter the FNC numbers (example: FNC12 K1 D0) or instruction words (example: MOV K1 D0). The application instructions you entered will be written in the ladder diagram.

Program conversion:

For the ladder diagram type program created by the instruction type entry method, it is necessary to convert the ladder diagram into the instruction list.

If the ladder diagram edit window is closed before completing conversion, the program you created will be erased (see Sec.6.2.3).

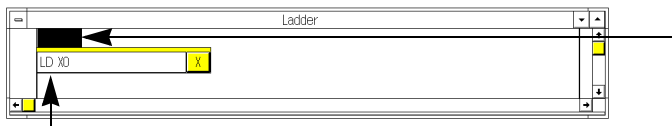

Instruction word entry box

In the ladder diagram edit window, position the cursor on a position where you want to enter a circuit symbol.

After that, enter the first character of the instruction word. The instruction word entry box will appear.

L **D** **SPACE** **X** **0**

Press the **←** key to determine the instruction word.

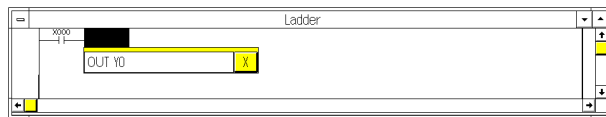
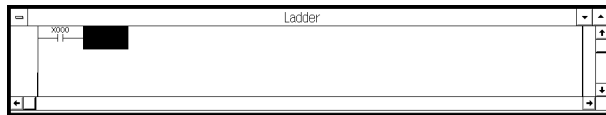

O **U** **T** **SPACE** **Y** **0**

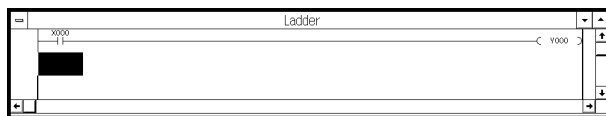

Press the **←** key to determine the instruction word.

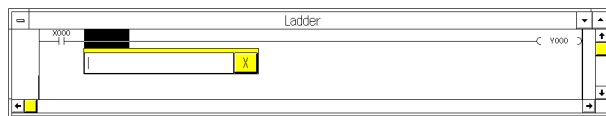

↑ **→**
Shift + **|**

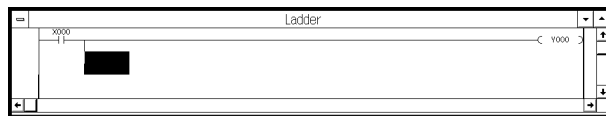

Press the **←** key to determine the instruction word.

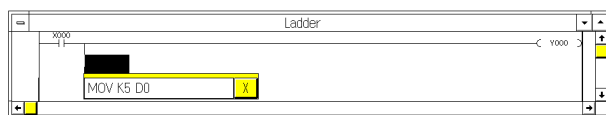

M **O** **V** **SPACE** **K** **5** **SPACE** **D** **0**

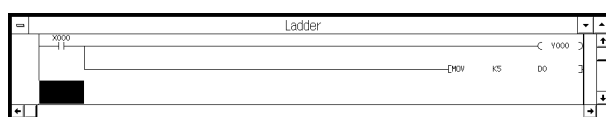

Press the **←** key to determine the instruction word.

The program will be determined at the completion of conversion.

6.2.3 Main items necessary for programming

Use the ladder diagram edit window to create circuit programs.

In the ladder diagram edit window, a circuit ladder diagram will be displayed, and you can directly edit the diagram.

Conversion

- The circuit ladder diagrams created in the ladder diagram edit window should be converted into instruction lists.
If the ladder diagram edit window is closed before completing conversion, the programs you created in the ladder diagram will be erased.
If you create programs in the list edit window, conversion will not be necessary. This is because instruction words are directly entered in the instruction lists.
- In the ladder diagram, non-converted sections will be dimmed in units of lines. At the completion of conversion, the dimmed section will be changed to normal, and the program step numbers will be determined.

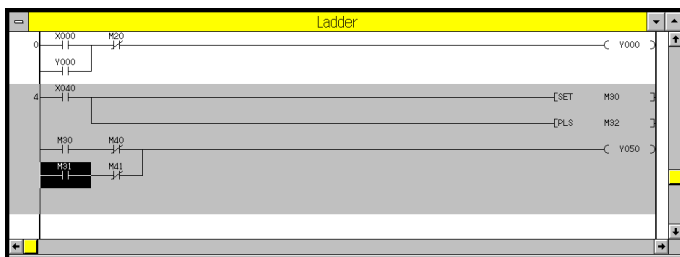

- Press the **[CNV]** (F4) key, or click Tools and then Convert to convert the ladder diagram you created into an instruction list.
- Conversion can be executed only if the circuit block is complete. If you execute conversion without completing the circuit block or with a wrong sequence program, an error message will appear on the display, and conversion will not be performed.
If an error message appear, correct a wrong section, and then execute conversion again.
- After determination of the step number, if you delete the entire circuit block by individually deleting the symbols or using the Line Delete command, be sure to enter a new circuit in the null section. If no circuit is entered, a circuit error will be detected at ladder diagram conversion.

To delete the entire block after determination of step number, specify the block range using the **[Shift] + [Up/Down]**, **[Shift] + dragging mouse**, or Block Select command, and then click the Cut or Delete command or press the Delete key.

To cancel the ladder diagram delete or edit operation, click the control menu box at the upper left corner of the ladder diagram window. The window will be closed. After that, open the window again to display the ladder diagram.

Be careful! When you close the ladder diagram window, all the edited data will be erased if they are not converted.

- Conversion can be executed for two or more circuit blocks at a time. Note that up to 200 lines can be converted at a time. When the number of non-converted lines exceeds 200, a message will appear on the display, and request conversion.
- Up to 50 lines of circuit blocks can be programmed in the ladder diagram edit window.
This means that the 51st and the subsequent lines cannot be entered. If you use the list edit window for programming, the 51st and subsequent lines will not be displayed, either. In addition, these excessive lines cannot be printed.
If the DOS version peripheral unit, A6GPP/PHP, or GP-80 is used for printing of ladder diagrams, limit the number of lines to 24 because these peripheral units cannot print more lines.

- After conversion of the MC (master control) or MCR (master control reset) instruction, the ladder display style of the FXGP/WIN-E V1.** will differ from that of the DOS version peripherals and A6GPP. The difference in the display style is shown below:

SW1PC- FXGP/EE (DOS)
 FXGP/WIN-E (V2.00 or later)
 A6GPP

FXGP/ WIN- E (V1.**)

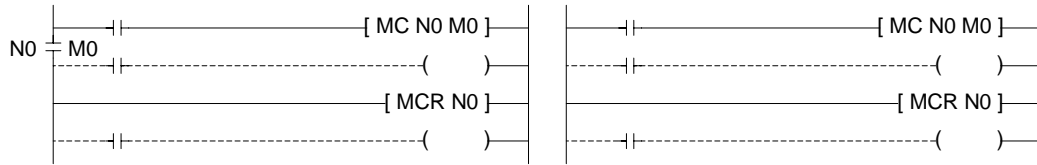

Use of double coil

It is possible to enter two or more OUT instructions for the same coil. However, operation of the programmable controller will be more complicated. At the completion of programming, click Option and then Program Check to check the program for double coils.

Automatic circuit turning

- Up to 11 contacts in series can be entered in each line. The 12th contact will be automatically sent to the next line. If a coil instruction is entered at the 12th point, it will be also sent to the next line. Such circuit turning can be performed up to 20 times, and up to 211 contacts can be entered. Turning point numbers 0 to 255 can be allocated to the turning points. These numbers can be manually changed (see Sec.6.2.1).
- If the STL (step ladder) instruction is in the ladder diagram, circuit turning will not be possible for the program following the STL instruction. In addition, circuit turning will not be possible for the internal circuit drawn in the SFC diagram edit window.

Unacceptable ladder diagram

The circuit blocks marked with "x" cannot be converted. Correct such unacceptable blocks into those marked with "O", and then convert them.

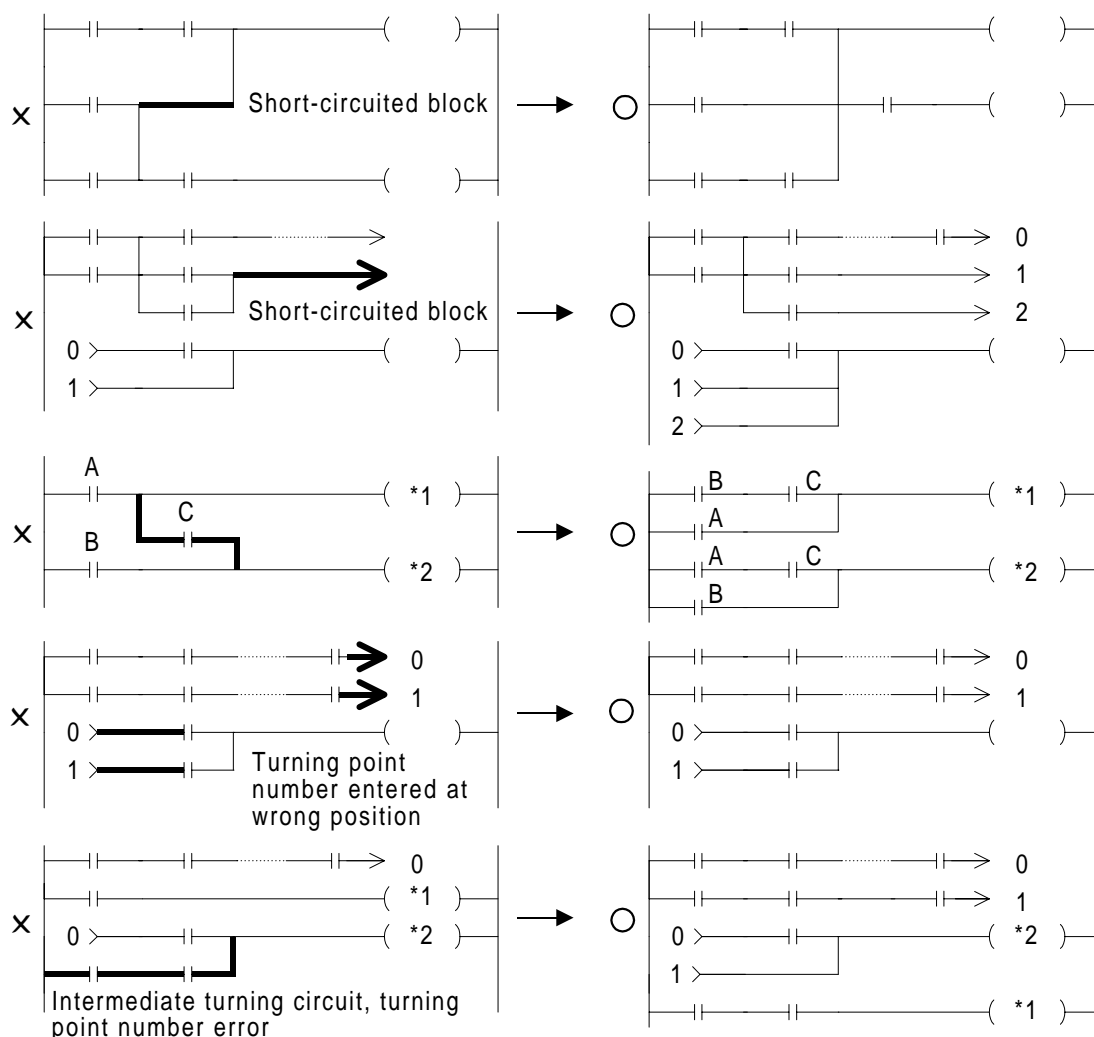

6.2.4 Creating circuit ladder diagram

Creating new ladder diagram

Click File and then New to create a new circuit ladder diagram.
To clear all the circuits stored, click Tools and then All Clear.

Creating ladder diagram

Use the circuit symbols allocated to function keys, tool pallet, list type entry method, or Tools command to create ladder diagrams.

For the circuit symbol entry method, refer to Sec.6.2.1 "Main operations necessary for entering circuit symbols".

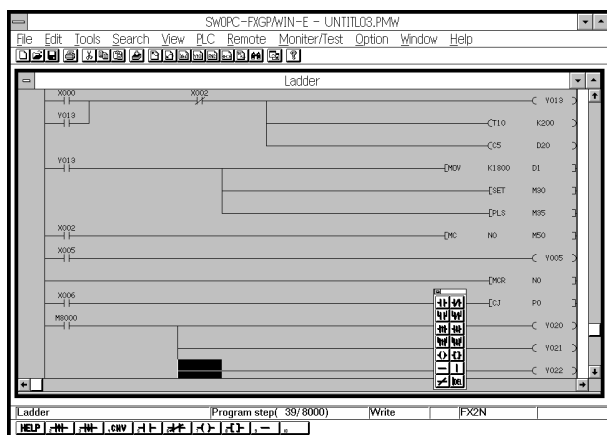

- Non-converted circuit blocks in the ladder diagram will be dimmed.



CNV (F4)
or
Tools → Convert

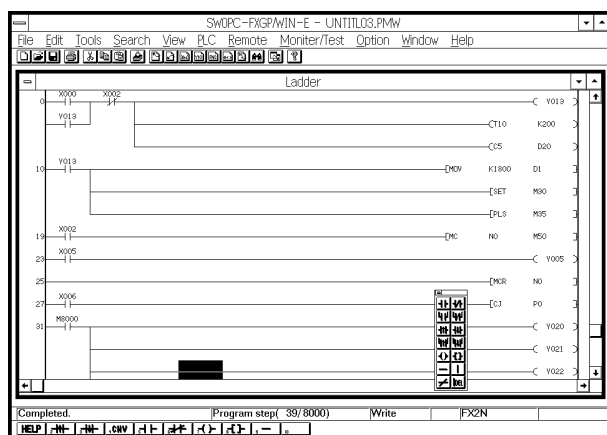

- When conversion is executed, the ladder diagram displayed on the screen will be converted into an instruction list.
- At the completion of conversion, the program steps will be determined, and the entire ladder diagram will be tidied up. In addition, dimmed blocks will be changed to normal.
- Even after conversion, automatic writing in the memory of the programmable controller can be executed in the run mode (see Sec. 5.6.6 and Sec. 5.8.10).

Editing

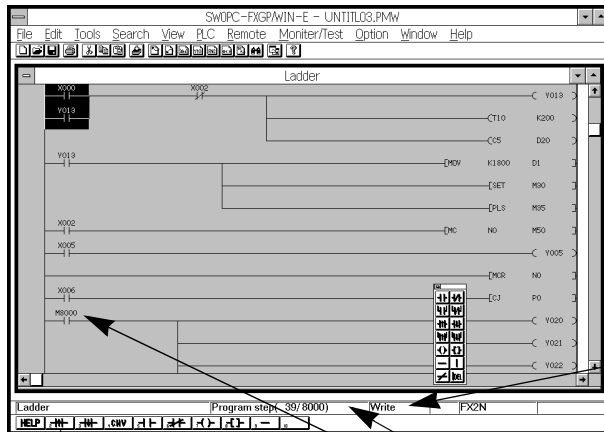

To edit the specified range, click Edit, and then click Cut, Copy, Paste, or Delete.

Press the Insert key to change the data entry mode from Overwrite to Insert, or vice versa.

Function keys (You can also click the mouse button on the desired function key to use the function.)

Indicates the number of steps used/total number of steps.

Press the Enter key on a contact or output coil, or double-click the mouse button on a contact or output coil. The instruction change dialog box will appear on the display. If you want to change an OUT instruction to a special coil, or want to change an application instruction that needs change in the number of steps, enter new data

Various functions of right mouse button

Click the right button of the mouse on the ladder diagram to perform following operations:

Operation	Description
Undo	Cancels the last operation.
Cut	Removes the graphic from the cursor position or specified range.
Copy	Copies the graphic from the cursor position or specified range.
Paste	Pastes the Clipboard data (graphic data temporarily stored) on the cursor position.
Edit cancel	Deletes the ladder diagram you edited.

Editing (after conversion)
Keys and commands used for editing ladder diagram

Item	Editing	Operation
Range specify	Specifies the edit range in unit of symbols in the circuit block.	Drag the mouse to specify the range in units of symbols. (Ctrl) + (→) / (←) / (↑) / (↓)
	Specifies the edit range in units of circuit blocks.	(↑Shift) + (↑) / (↓)
		(↑Shift) + mouse dragging
		Edit → Block Select
Symbol delete	Deletes the cursor-positioned symbol.	(Delete)
		Edit → Delete
		Edit → Cut
	Deletes the left side of the cursor.	(Back Space)
	Deletes a vertical line.	(↑Shift) + (F8)
		Tools → Wire → IDEL Tool pallet (IDEL)
Deletes a line or symbol.	(Ctrl) + (Alt) + (→) / (←) / (↑) / (↓)	
Copy	Copies symbols in the specified range.	Edit → Copy
		(Ctrl) + (C)
Paste	Pastes data sent from the clip board.	Edit → Paste
		(Ctrl) + (V)
Line edit	Inserts one line at the cursor position.	Edit → Line Insert
		(↑Shift) + (Insert)
	Deletes the cursor-positioned line (right side of the cursor).	Edit → Line Delete (↑Shift) + (Delete)
Block delete	Deletes the step-number-determined circuit blocks.	Specify the edit range in units of blocks. Edit → Cut or Delete
Edit cancel	Deletes the ladder diagram you edited.	Edit → Edit Cancel
Undo	Cancels the last operation, and returns to the previous condition. (Circuit block conversion operation, however, will not be canceled.)	Edit → Undo
		(Ctrl) + (Z)
Scroll	Scrolls the screen (or moves the cursor).	Scroll bar
		(↑) / (↓)
	(Page Up) / (Page Down)	
Jumps to the specified position.	Search → Top, end, device, instruction/coil, step number, tag	
Device Change	Changes devices.	Search → Replace, a-contact/b-contact change, convert
Comment	Enter or changes comments.	Edit → Device name, device comment, coil comment, block comment



Note regarding circuit block delete

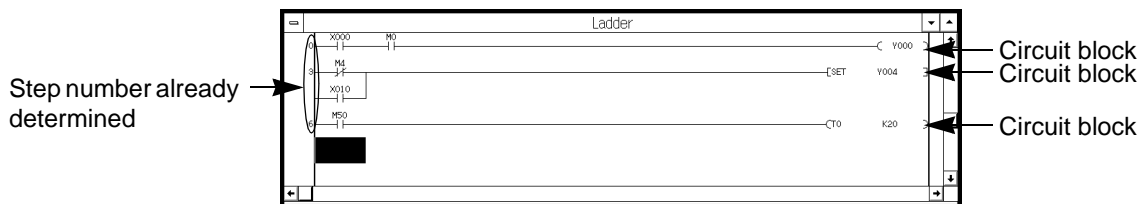

If step numbers are already determined for the circuit blocks, you can delete the blocks by following the procedure below:

- 1) If you want to delete circuit blocks, specify the delete range using the **Shift** + **↑**/**↓**, **Shift** + mouse dragging, or Block Select command.
- 2) Click Cut or Delete, or press the Delete key to delete the specified blocks. When deleted, the corresponding instructions will be also deleted from the instruction list. It is, therefore, not necessary to convert the changed ladder diagram into an instruction list.

After deleting a step-number-determined entire circuit block in units of symbols or using the Line Delete command, be sure to enter a new circuit program in the blank line. If a line remains blank, a conversion error will be detected. To delete an entire circuit block, be sure to follow the above procedure.

To cancel the ladder diagram delete or edit operation, click the control menu box at the upper left corner of the ladder diagram window. The window will be closed. After that, open the window again to display the ladder diagram.

Be careful!

When you close the ladder diagram window, all the edited data will be erased if they are not converted.

Instruction word entry method and circuit ladder diagram displayed:

[LDP] (Load pulse, rise detection, operation start)

LDP instruction X 0 ←

 ↑ ↑

 Device symbol Device number

[ANDP] (AND pulse, rise detection, series connection)

ANDP instruction X 1 ←

Circuit ladder diagram displayed:

[LDF] (Load pulse, fall detection, operation start)

LDF instruction X 0 ←

 ↑ ↑

 Device symbol Device number

[ANDF] (AND pulse, fall detection, series connection)

ANDF instruction X 1 ←

Circuit ladder diagram display:

Device applicable to LDP, LDF, ANDP and ANDF instructions:

- | | | |
|------------------|---------------------|-------------|
| X (input relay) | M (auxiliary relay) | T (timer) |
| Y (output relay) | S (state) | C (counter) |

Instruction word entry method and circuit ladder diagram displayed:

[OR] (OR, parallel connection, a-contact)

or
 (OR)

OR instruction ↑ ↑ ↑
Device symbol Device number Device symbol

[ORI] (OR inverse, parallel connection, b-contact)

or
 + (ORI)

ORI instruction ↑ ↑ ↑
Device symbol Device number Device symbol

Circuit ladder diagram displayed:

[ORP] (OR pulse, rise detection, parallel connection)

ORP instruction ↑ ↑ ↑
Device symbol Device number Device symbol

[ORF] (OR pulse, fall detection, parallel connection)

ORF instruction

Circuit ladder diagram displayed:

Device applicable to OR, ORI, ORP and ORF instructions:

- | | | |
|------------------|---------------------|-------------|
| X (input relay) | M (auxiliary relay) | T (timer) |
| Y (output relay) | S (state) | C (counter) |

Instruction word entry method and circuit ladder diagram displayed

[STL] (Step ladder, step ladder start)

S T L SPACE S 0 ↵

STL instruction ↑ ↑
 Device symbol Device number

Circuit ladder diagram display:

Device applicable to STL instructions:

S (State)

Instruction word entry method: Specifying device name

To specify the device, you can enter a device name in place of a device number.

Example:

L D SPACE ' L S 1 ' ↵

Instruction word Device name stored for X, Y, M, S, T and C

F5 (LD) ' L S 1 ' ↵

Function key
for entering
instruction word

Entering coil instruction

Instruction word entry method and circuit ladder diagram displayed:

[OUT] (Output, driving output coil)

[O] [U] [T] [SPACE] [Y] [0] [↵] or [F7] (OUT) [Y] [0] [↵]
 OUT instruction Device symbol Y, M or S Device number Device symbol Y, M or S

Circuit ladder diagram display:

```

    -----( Y000 )-----
              OUT
    
```

[OUT] (Output, driving timer/counter)

[O] [U] [T] [SPACE] [T] [0] [SPACE] [K] [1] [0] [0] [↵]
 OUT instruction Device symbol T, C Device number Specifying decimal type constant

[F7] (OUT) [T] [0] [SPACE] [K] [1] [0] [0] [↵]
 Function key Device symbol T, C Device number Specifying decimal type constant

[O] [U] [T] [SPACE] [C] [1] [SPACE] [D] [5] [0] [↵]
 OUT instruction Device symbol T, C Device number Data register for indirect specification

[F7] (OUT) [C] [1] [SPACE] [D] [5] [0] [↵]
 Function key Device symbol T, C Device number Data register for indirect specification

When constant is specified
How to enter instruction
word OUT T0 K100

When indirectly specified
How to enter instruction
word OUT C1 D50

Circuit ladder diagram display:

```

    -----( T0 K100 )-----
              Timer
    -----( C1 D50 )-----
              Counter
    
```

Device applicable to OUT instructions:

- | | | |
|---------------------|-----------|-------------|
| Y (output relay) | S (state) | T (timer) |
| M (auxiliary relay) | | C (counter) |

Instruction word entry method: Specifying device name

To specify the device, you can enter a device name in place of a device number.

Example:

O U T SPACE ' R Y 1 ' ←
OUT instruction Device name stored for Y, M and S

F7(OUT) ' R Y 1 ' ←
Function key Device name stored for Y, M and S

O U T SPACE C 1 ← ' 1 0 S ' ←
OUT instruction ↑ ↑ Device name stored for data register
 Device symbol T or C Device number used for indirect specification

O U T SPACE ' W A I T ' SPACE ' 1 0 S ' ←
OUT instruction Device name stored for Device name stored for data register
 T and C used for indirect specification

Entering single instruction

Instruction word entry method and circuit ladder diagram displayed

[ANB] (AND block, serial connection between blocks)

A **N** **B** **←** or **F8** (ANB) **←**
 ANB instruction Function key

Circuit ladder diagram displayed:

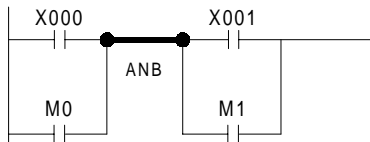

[ORB] (OR block, parallel connection between blocks)

O **R** **B** **←** or **SHIFT** + **F8** (ORB) **←**
 ORB instruction Function key

Circuit ladder diagram displayed:

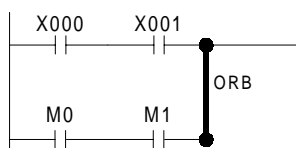

[MPS] (Push, operation data storage)
 [MRD] (Read, reading out stored data)
 [MPP] (Pop, resetting read- out data)

M **P** **S** **←**
 MPS, MRD or MPP instruction

Circuit ladder diagram displayed:

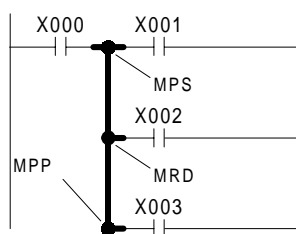

[NOP] (NOP, no-operation)
 [RET] (Return, step ladder end)
 [End] (End, program end)

N **O** **P** **↵**

NOP, RET or END instruction

Circuit ladder diagram displayed:

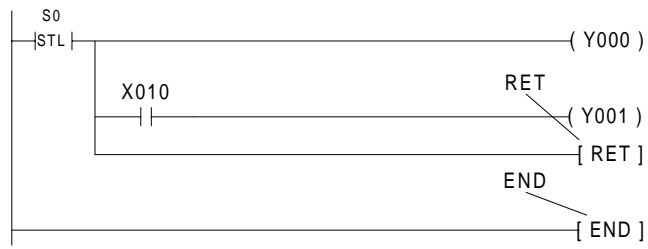

NOP instructions will not be displayed in the ladder diagram.

[P] (Pointer, for labeling)

P **0** **↵**

Pointer number (P0-P63)

[I] (Pointer, for interrupt)

I **3** **0** **1** **↵**

Pointer number

Circuit ladder diagram displayed:

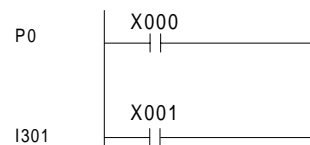

Entering special coil or application instruction:

For the special coil and application instruction entry methods in the list edit window, refer to those used in the ladder diagram edit window.

- Special coil: [SET] (Setting, holding operation)
 [RST] (Reset, canceling held operation)
 [PLS] (Pulse, rise detection)
 [PLF] (Pulse, fall detection)
 [MC] (Master control, common series contact)
 [MCR] (Master control reset, canceling common series contact)

Application instruction: FNC00- FNC246

For the above instruction entry method, refer to Sec.6.2.1 "Main operations necessary for entering circuit symbols". Note that in the ladder diagram edit window, the data entry dialog box will appear so that you can directly enter the instruction word at the cursor position, but in the list edit window, this dialog box will not appear.



Instruction entry using Instruction command

In the list edit window, you can directly enter instruction words or device numbers in the cursor-positioned line using the keyboard. However, if you want to use lists or dialog boxes for easy programming, use the Instruction command.

Instruction		
39	OUT	Y022
40	OUT	Y023
41	PO	
42	LD	X020
43	OUT	Y025
44	NOP	
45	NOP	
46	NOP	
47	NOP	
48	NOP	
49	NOP	
50	NOP	
51	NOP	

Displays instruction types. Displays instructions.

The 'Instruction reference' dialog box contains two dropdown menus. The 'Instruction type' dropdown is open, showing categories like Contact, Coil, Connection, Other, Program flow, Move, compare, etc., Arithmetic logic, Rotation shift, Data, High-speed proc., and Handy instruction. The 'Instruction' dropdown is also open, showing specific instructions such as CMP(10), ZCP(11), MOV(12), SMOV(13), CML(14), BMOV(15), and FMOV(16). There are checkboxes for 'Double word instruction' and 'Pulse instruction'. Buttons for 'OK', 'Cancel', and 'Help' are present.

If you want to use the specified instruction as the 32-bit or pulse execution type, click the mouse button in this box to enter the check mark.

You can enter an instruction in this box by selecting it from the list. Or you can directly enter an instruction word or FNC number in this box.
 Example: LD, AND, OUT, ZCP, DZCP, FNC11, FNCD11P

The 'Instruction' dialog box has an 'Instruction' field containing 'zcp' and a 'Reference' button. Below it is a 'Device' section with five empty input fields, each followed by a 'Reference' button. Buttons for 'OK', 'Cancel', and 'Help' are on the right.

The operand necessary for the specified instruction is described in this box, and the system will enter the data entry waiting mode.

The 'Device details' dialog box shows a 'Device' field with 'D0' entered. It has two columns: 'Kind of device' and 'Device name'. The 'Kind of device' column lists various device types like X000...377, Y000...377, M0...8255, etc. The 'Device name' column lists corresponding names like 100ms, 150ms, 7SEG1, etc. Buttons for 'OK', 'Cancel', and 'Help' are on the right.

You can specify the operand or device name.

6.3.2 Creating instruction list

Creating new list

Click File and then New to create a new instruction list.
To clear all the circuits stored, click Tools and then All Clear.

Creating/editing instruction list

In the list edit window, position the cursor and then directly enter an instruction word at the cursor position, or use the circuit symbols allocated to function keys or the Instruction command on the Tools menu to create an instruction list.

For the instruction word entry method, refer to Sec.6.3.1 "Main operations necessary for entering instruction words".

For the instructions regarding programming, refer to Sec.6.3.2 "Creating instruction list".

To specify the edit range in the list edit window, use the **[Shift]** + **[↑]**/**[↓]**, mouse dragging, or **[Shift]** + mouse clicking.

To edit the specified range, click Edit, and then click Cut, Copy, Paste, or Delete.

Step number	Instruction word	Operand 1	Operand 2
0	LD	X000	
1	OR	Y013	
2	ANI	X002	
3	OUT	Y013	
4	OUT	T10	K200
7	OUT	C5	D20
10	LD	Y013	
11	MOV	K1800	D1
16	SET	M30	
17	PLS	M35	
19	LD	X002	
20	MC	NO	M50
23	LD	X005	
24	OUT	Y005	
25	MCR	NO	
27	LD	X006	
28	CJ	P0	
31	LD	M8000	
32	OUT	Y020	
33	OUT	Y021	
34	OUT	Y022	
35	OUT	Y023	
36	PO		
37	LD	X020	
38	OUT	Y025	
39	NOP		
40	NOP		

Used steps (39/2000) | Insert | FX

HELP | .LD | .AND | .OR | .AND NOT

Keys and commands used for editingSymbol delete:

Delete: Deletes the symbol at the cursor position.

NOP operation:

Edit : All write, all insert, all delete

Scroll:

- Page Up, Page Down, ↑, ↓, scroll bar
- Search : Top, end, device name, device, instruction, contact/ coil, step number, tag set, tag jump

Device change:

Search : Replace, a-contact/ b-contact change, convert

Comment entry:

To enter comments, use the All Entry screen by clicking View and then Comment.
Or enter comments in the ladder diagram edit window.

MEMO

1	Introduction
2	Installing FXGP/WIN-E
3	Main Operation
4	Work Windows and their Functions
5	Menu Bar Commands and their Functions
6	Creating Ladder and Instruction Programs
7	Creating SFC Programs
8	Remote Maintenance Using Telephone Line
	Appendix

7. Creating SFC Programs

SFC programming is to enter symbols in the SFC (sequential flow chart) to determine the flow of control as specified in the IEC standards.
 For a detailed description of SFC control, refer to the instruction manual of the programmable controller.

7.1 Description of SFC

7.1.1 Types of SFC

The SFC has a single flow basically.
 The single flow type program can control sequences of simple motions. If various input conditions are set or the operator enters various commands, use the selective branch or simultaneous branch type.

Single flow:

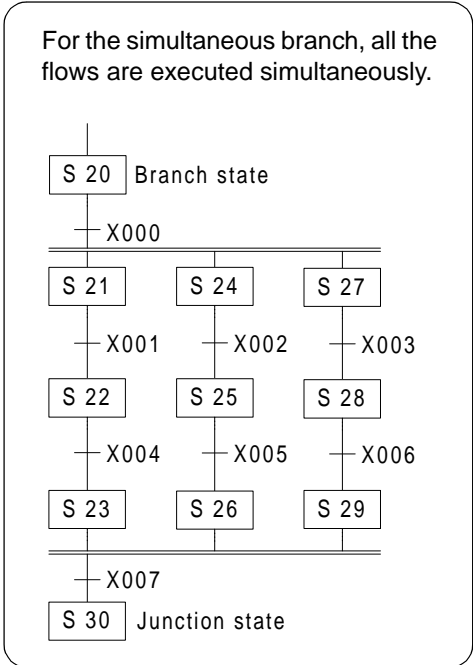
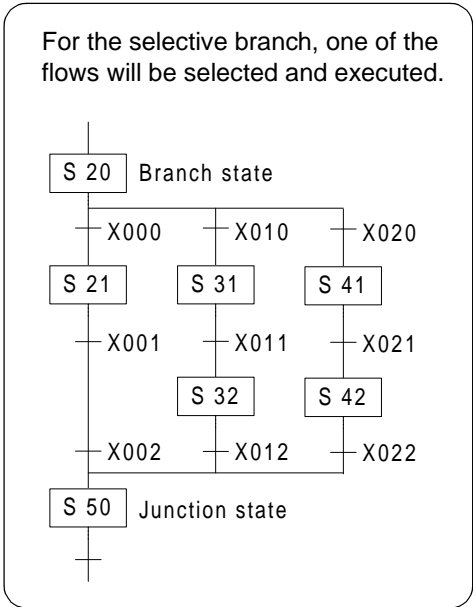
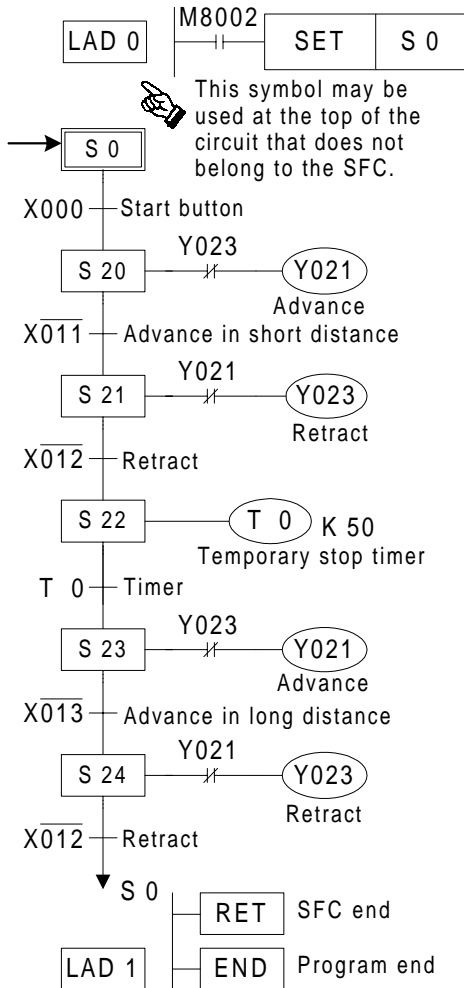

7.1.2 Program types

When you create programs using the SFC, the SFC sections and ladder diagram sections (inner ladders) should be separately programmed.

The SFC type section consists of ladder blocks and state blocks.

To create sequence programs used for control, enter symbols, such as SET SO (ladder block), Y000 (state), and TRAN (transition). These sequence programs will be controlled as inner ladders.

SFC section:

To use a SFC for programming, enter SFC symbols to determine the flow.

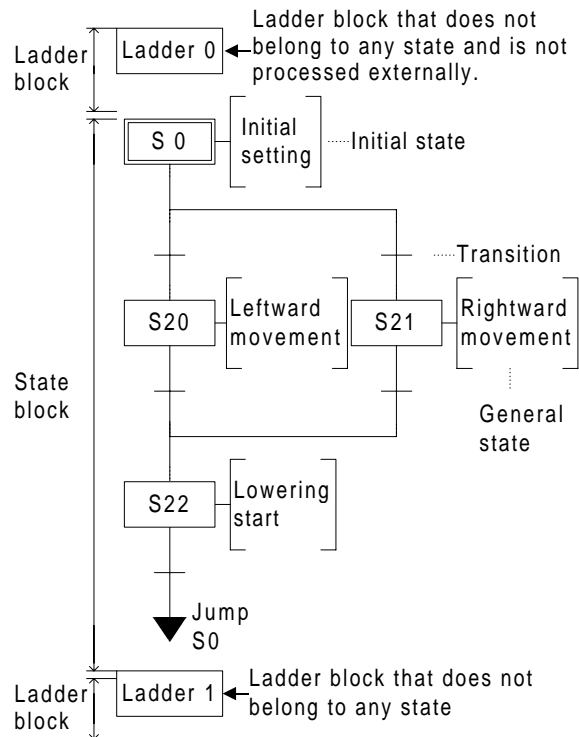

Ladder section:

Create inner ladders in the ladder diagram to specify the control of each process, conditions to transfer to the next state, etc.

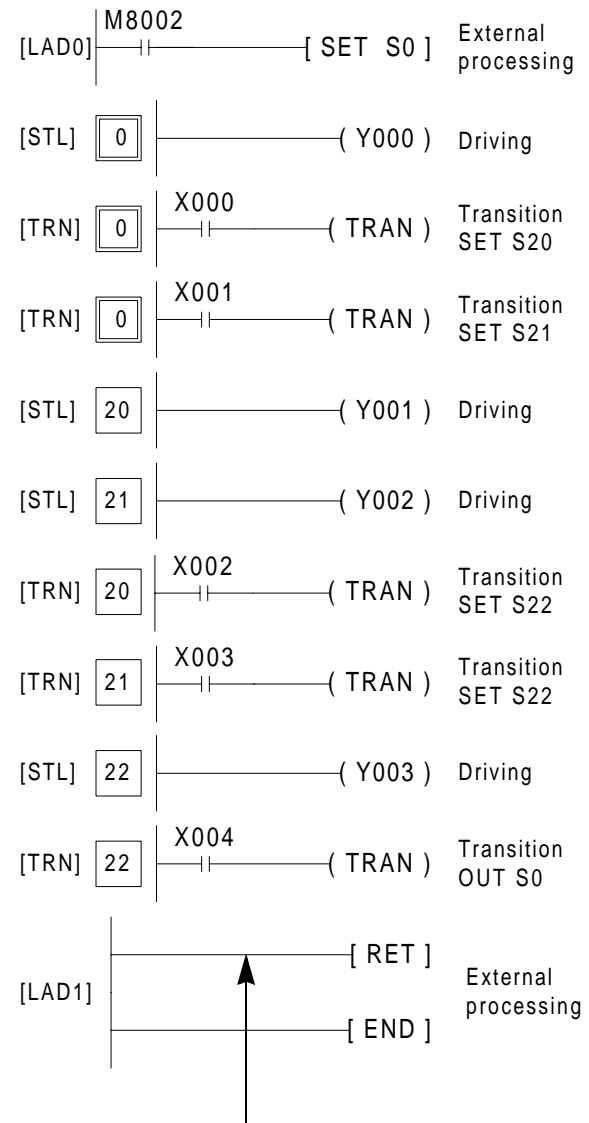

When you create a ladder block after the state block, the FXGP/WIN-E will automatically enter the RET instruction. For this reason, do not enter any RET in the program.

7.1.3 Structure of SFC section

The rows, columns, and cursor position in the SFC section are described below:

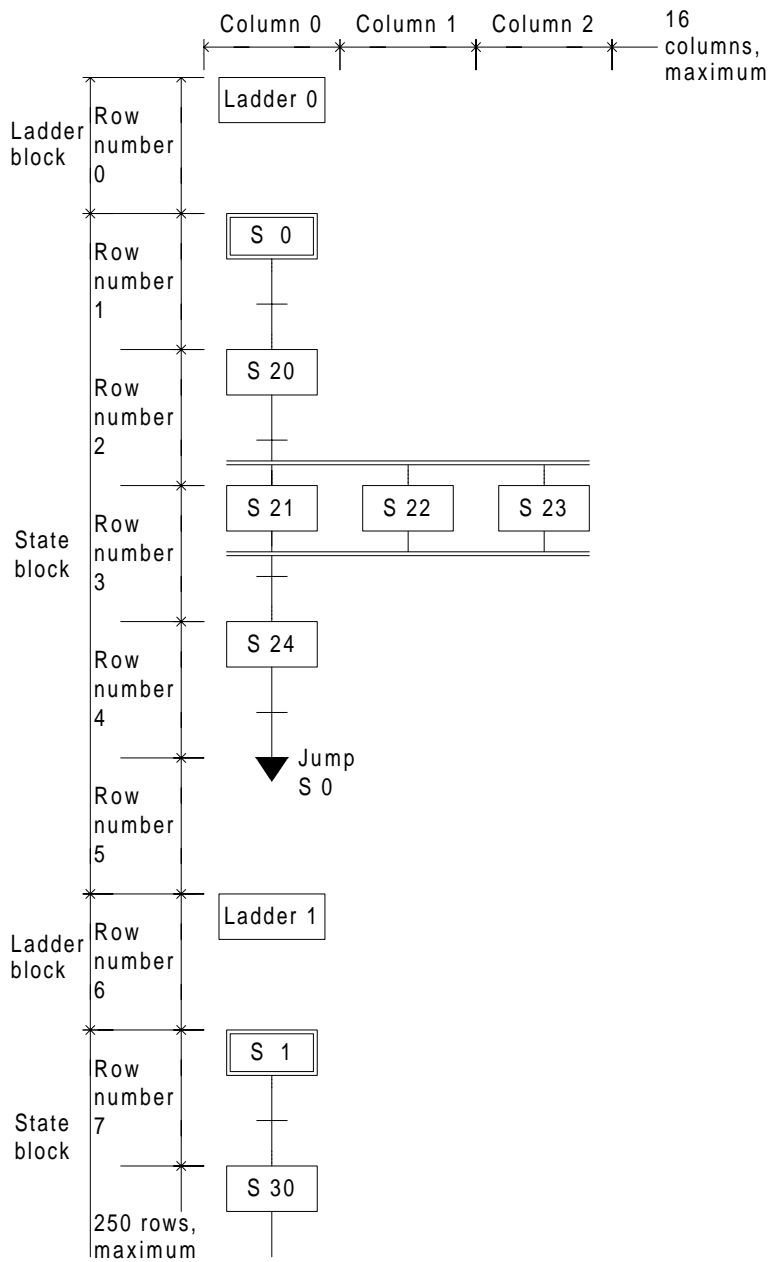

Row number:

Respective states including ladder blocks have their own row numbers.







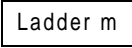

Column number:

Respective states have their own column numbers. Up to 16 columns can be used for programming.

7.2 Creating SFC Programs

7.2.1 Main operations necessary for entering SFC symbols

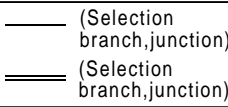
Use the function keys to enter the symbols in the SFC program.

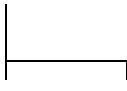
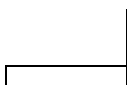
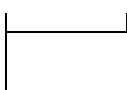
Item	Symbol displayed on screen	Function key	Remarks	
Ladder block		F8	m=ladder block number, automatically attached	
Initial state		↑Shift + F4	Sn=S0 to S9. S0 to S9 will be controlled as the initial states, and the initial state depends on the state number.	
General state		↑Shift + F4	Sn=S10 to S899.	
Jump (loop)		F6	Sn=S0 to S899.	
Jump (reset)		F7	Sn=S0 to S899.	
Transition (transition condition)		↑Shift + F5	The transition condition will be written.	
Vertical line		↑Shift + F9	Connects a state to another state.	
Horizontal line		F9	Automatically recognized as the selective or simultaneous branch line, and the recognition result depends on the symbol-written position.	
Combined symbol	State + transition 	F5	Sn=S10 to S899.	
	Branch junction		↑Shift + F6	Automatically recognized as the selective or simultaneous branch line, and the recognition result depends on the symbol-written position.
			↑Shift + F7	
	↑Shift + F8			

7.2.2 Cursor position and entering symbol

Regarding SFC edit window, the relation between cursor positions and symbols you can enter are shown in the figure below.

The selective branches or simultaneous branches will be automatically recognized by the connection position.

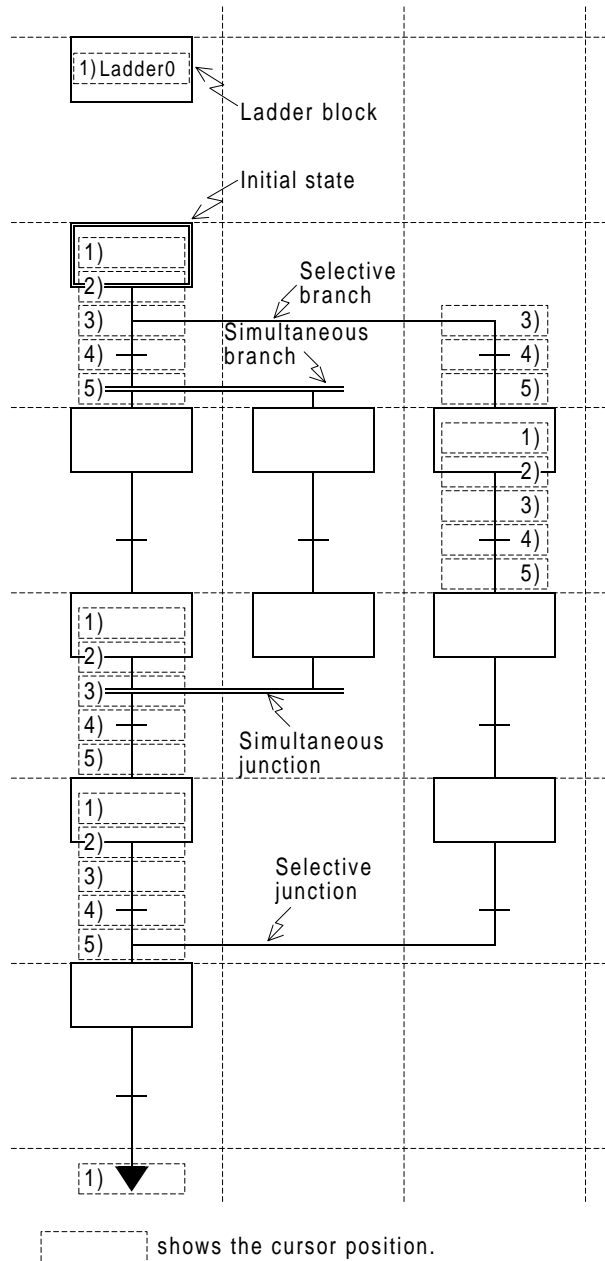

- 1) State entry position (creation of inner ladder), entry of jump symbol or creation of ladder block
- 2) Connection position where state and next step are connected to each other
- 3) Junction of selective branches and simultaneous branches
- 4) Transition entry position (creation of transition condition, creation of inner ladder)
- 5) Junction of simultaneous branches or selective branches

7.2.3 Main items necessary for creating SFC

Use of programming window

Open the SFC edit window to use the SFC for programming.
Click View and then SFC to open the SFC edit window.

Conversion

- After creating a SFC program and inner ladder diagram in the SFC edit window, be sure to convert them into an instruction list.
Non-converted programs will be erased when the SFC edit window is closed.
- Press the **CNV** (**F4**) key, or click Tools and then Convert to convert programs.
- Be sure to convert both the inner ladder diagram and SFC.

Editing inner ladder diagram

- To display, create, or edit a ladder block or inner ladder of a state or transition, position the cursor and then click View and then Inner Ladder View.
- To edit a ladder block or inner ladder of a state.
- When you create a ladder block after the state block, the FXGP/WIN-E will automatically enter the RET instruction. For this reason, do not enter any RET in the program.

Sequence instructions usable for state:

State		Instruction	LD/LDI/LDP/LDF, AND/ANI/ANDP/ANDE, OR/ORI/ORP/ORE,INV, OUT,SET/RST,PLS/PLF	ANB/ORB MPS/MRD/MPP	MC/MCR
			Usable	Usable	Unusable
Initial state, general state			Usable	Usable	Unusable
Branch, junction, state	Output operation		Usable	Usable	Unusable
	Transition operation		Usable	Unusable	Unusable

- The STL instruction cannot be used in the interrupt programs or subroutine programs.
- Use of jump instructions in the STL instruction is not inhibited. It is, however, recommended that you should not use any jump instructions in the STL instruction. This is because operation will be too complicated.
- When the MC (master control) or MCR (master control reset) instruction is entered, the ladder will be displayed in the same way as the FXGP/WIN-E V1.** (see Sec. 6.2.3).
- In the inner ladder of transition (transition conditions), circuit (ladder) turning is not possible. Even if two or more transition conditions exist, these conditions should be programmed in one transition circuit.

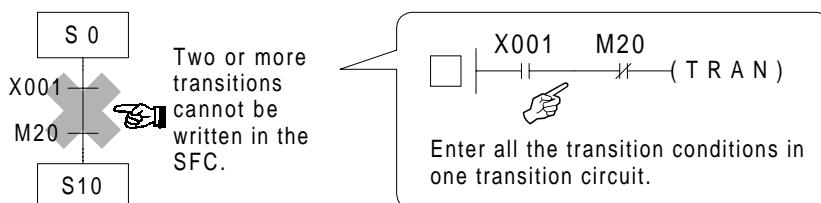

- If no inner ladder is created for a state or transition, the state or transition will be marked with "**". When an inner ladder is created, the mark will disappear.
- You can create the SFC first to determine the flow, and then you can sequentially create inner ladders. If the SFC without inner ladder diagram is converted, the instruction list of flow only will be created. This SFC can be displayed again, and then inner ladders can be added to the SFC to complete it.
- Dummy state entry method
Follow the procedure below to enter a dummy state in the SFC:
 - 1) Enter a state symbol (symbol for dummy state).
No program will be processed in this state, therefore it is not necessary to create an inner ladder. On the screen, there is an asterisk "*" to show that there is no inner ladder.
 - 2) Create a transition to go to the next state from the dummy state.

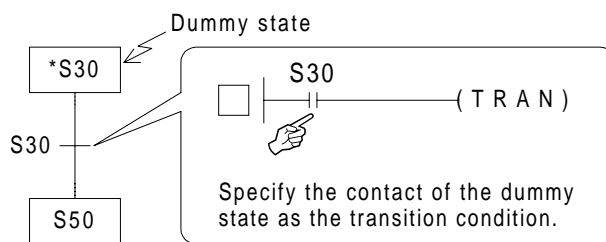

- 3) The dummy state is marked with "**", but convert the program ignoring the asterisk.

Remarks

To jump to the same state in the SFC, do not write the same jump state twice or more. If you write the same jump state in two or more different places, the circuit you created may not function properly.

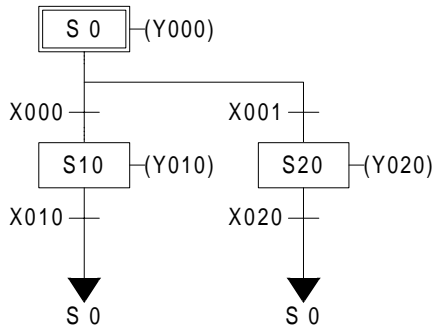

Change

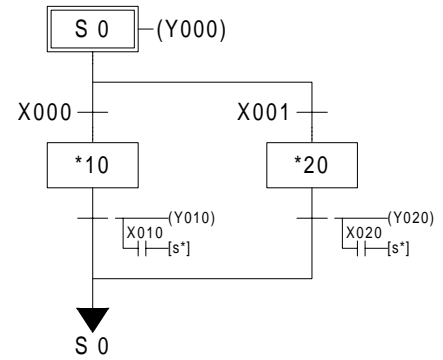

S10 and S20 are included in the inner ladders of transitions X010 and X020.

Correct the ladder diagram as follows:

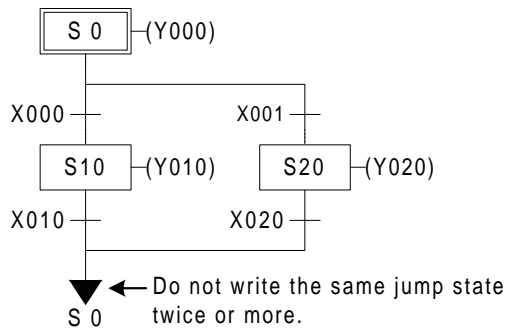

In the following circuit, the same problem will occur. Do not write the same jump state twice or more.

Unacceptable circuit

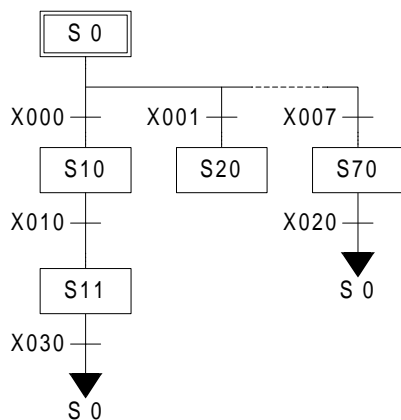

Change



Acceptable circuit

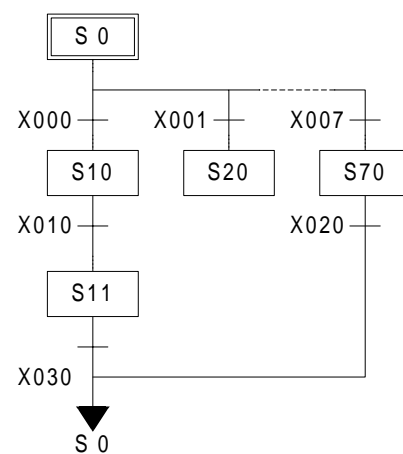

7.2.4 Creating SFC

Creating new SFC

Click File and then New. Select SFC edit window from the list of programming windows. Or use the View menu to open the SFC edit window.

Creating SFC

Create a SFC using the circuit symbols allocated to the function keys. For the SFC symbol entry method, refer to Sec.7.2.1 "Main operations necessary for entering SFC symbols".

Editing

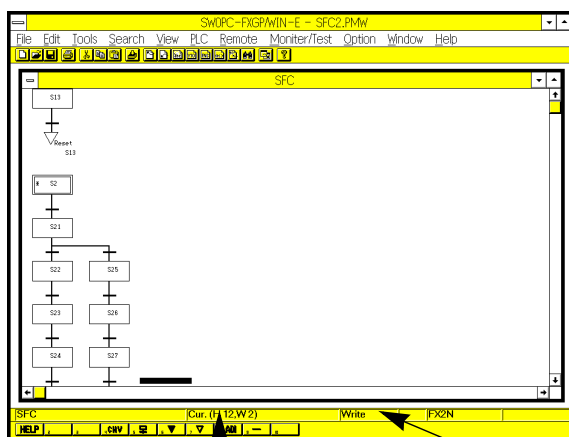

Cursor coordinates

Function key (You can also click the mouse button on the desired function key to use the function.)

Press the  key to change the data entry mode from Overwrite to Insert, or vice versa.

Keys and commands used for editing





Symbol delete:

-  key (cursor position)
- Edit → Delete (cursor position)

Block insert:

- Insert an initial state to add an SFC block.

Scroll:

- , , , or  keys, scroll bar (screen scroll)
- Search (top, end, device name, state number)

Inner ladder:

- View → Inner Ladder (To edit inner ladders, refer to Sec.6.2 "Creating Ladder Programs" or Sec.7.2.3 "Main items necessary for creating SFC".)

MEMO

1	Introduction
2	Installing FXGP/WIN-E
3	Main Operation
4	Work Windows and their Functions
5	Menu Bar Commands and their Functions
6	Creating Ladder and Instruction Programs
7	Creating SFC Programs
8	Remote Maintenance Using Telephone Line
	Appendix

8. Remote Maintenance Using Telephone Line

The FXGP/WIN-E has the remote access function that enables program transfer and monitoring through the telephone line. For this remote access function, the computer should be connected to the FX2N and FX2NC programmable controller via modems.

In addition, the FXGP/WIN-E has the file transfer function that enables file sending and receiving between computers through the telephone line. For this file transfer function, the computers should be connected to each other via modems. If you use this function, you can send and receive sequence programs, comment files, FXGP/WIN-E data files, and other general files to another computer through the telephone line.

8.1 System Configuration and Functions

8.1.1 Remote access to programmable controller

System configuration

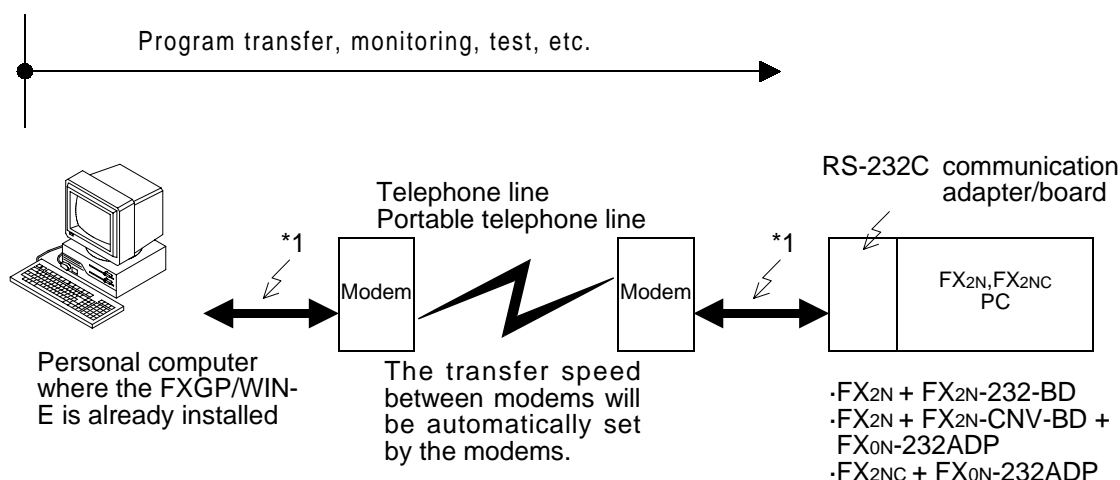

*1: Be sure to use the cable specified by the modem manufacturer to connect the personal computer to the modem, or connect the programmable controller to the modem. The transfer speed will be fixed to 9,600 bps.

Functions

The personal computer can be connected to the modem of the Programmable controller through the telephone line.

You can automatically connect to the desired programmable controller by selecting the corresponding station from those stored in the personal computer. In addition, you can manually connect the computer to the programmable controller by manually setting the telephone number of the programmable controller.

When connected, various commands on the PLC and Monitor/ Test menus will be valid.

These commands are listed belowCommands on PLC menu

- Transfers
- Register Data Transfers
- PLC Memory Clear
- Serial Setting (D8120)
- PLC Keyword Current or Delete
- Runtime Program Changes
- Remote Run/Stop
- Diagnostics
- Sampling Trace

Commands on Monitor/Test menu

- Start monitor
- Stop Monitor
- Dynamic Monitor
- Entry Device Monitor
- Forced Y Output
- Forced On/Off
- Change Current Values
- Change Setting Values

8.1.2 Sending/receiving files

System configuration

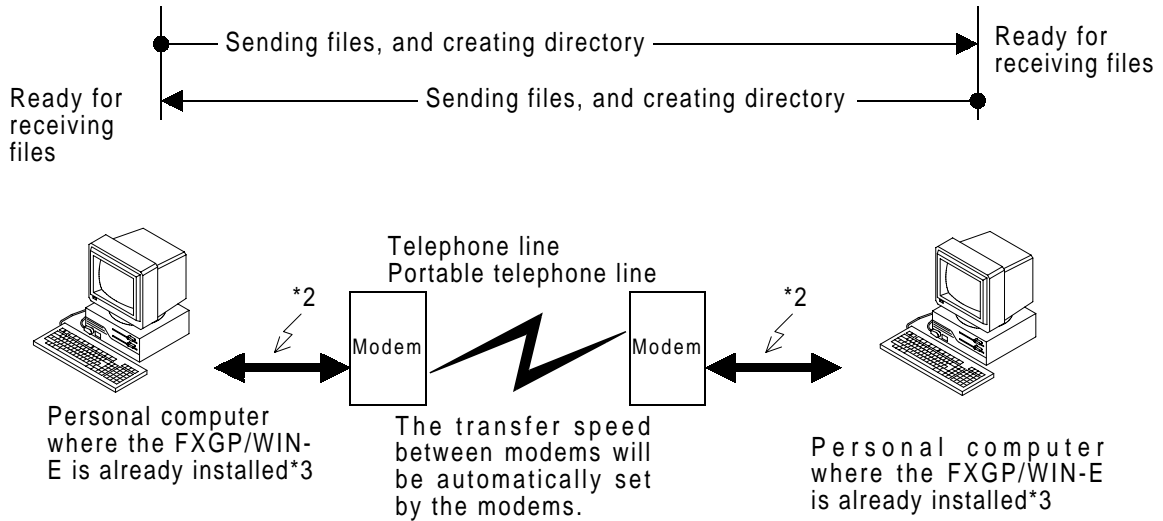

- *2: Be sure to use the cable specified by the modem manufacturer to connect the personal computer to the modem.
- *3: The transfer speed will be fixed to 19,200 bps. If the RS-232C port of the personal computer cannot keep up with such high speed, this file sending/ receiving function cannot be used. (For the transfer speed of the RS-232C port, refer to the operation manual of the personal computer.)

Functions

Use one of the personal computers as the receiver. Use the other personal computer to send one or more files specified on the screen to the desired directory of the receiver computer.

If you do not specify the directory of the receiver computer, the received files will be stored in sub-directory FILE of the FXGP/WIN-E.

If you specify a new directory, the new directory will be created, and then the received files will be stored in the directory.

Transfer files from the receiver computer to the sender computer to change the transfer direction between the personal computers.

Using this file transfer function, you can send and receive the FXGP/WIN-E files and general files.

8.1.3 Caution

- 1) If you frequently use the remote access system of the programmable controller, it is recommended that you should use a password for the sequence programs. The password will prevent the third party from illegal access to your sequence programs.(See Sec.5.6.5 and Sec.5.8.3.)
- 2) During communication through the telephone line, if another person dials the phone number currently used for communication, a communication error may occur, or the line will be disconnected.
- 3) If the telephone line is connected to the personal computer via other business phones or private branch exchange, the modem may not function properly due to wrong connector or signal type. For more information, contact the person in charge of the private telephone line.
- 4) Depending on the telephone line conditions or the field intensity of the portable telephone, communication may not be possible, or the line may be disconnected during communication.
The file transfer function described in Sec.8.1.2 may not be valid if a wrong modem is connected to the computer, or a wrong computer is used.

8.2 Operation Procedures

8.2.1 Remote access to programmable controller

Connect the FXGP/WIN-E installed computer to the Programmable controller using the telephone line in order to enable remote access to the programmable controller.

Access procedure

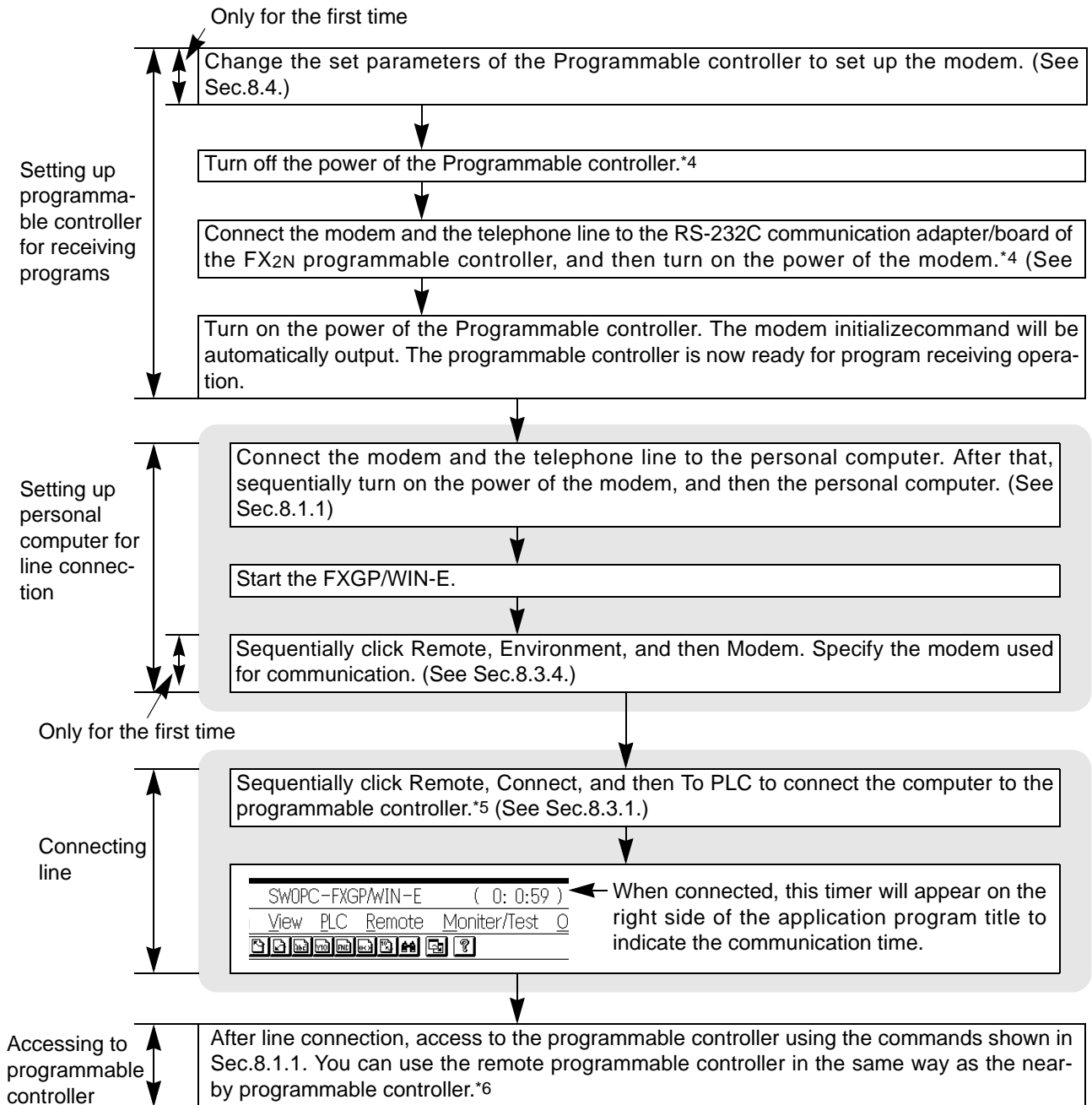

- *4: Be sure to turn on the power of the modem first, and then that of the programmable controller. This is because the programmable controller will send the modem initialize command to the modem when the power of the programmable controller is turned on. If you turn on the power of the programmable controller without turning on the power of the modem, the modem initialize command will not be sent to the modem, therefore communication error will occur when you access to the remote programmable controller. After turning on the power of both units, if you turn off the power of the modem only, the initialize command will be canceled, therefore communication error will occur. In this case, turn off the power of both units, and then turn on the power of the modem first, and then that of the programmable controller.
- *5: Be sure to use the To PLC command to connect the computer to the programmable controller. If you use the To File Transfer command, communication with the programmable controller will not be possible.
- *6: If you access to the programmable controller immediately after line connection, a communication error may occur. This is because the modem is still not ready for communication. Wait several seconds, and then access to the programmable controller.

8.2.2 File transfer

Connect the FXGP/WIN-E installed computer to another FXGP/WIN-E installed computer using the telephone line in order to enable file sending and receiving between these computers.

Transfer procedure

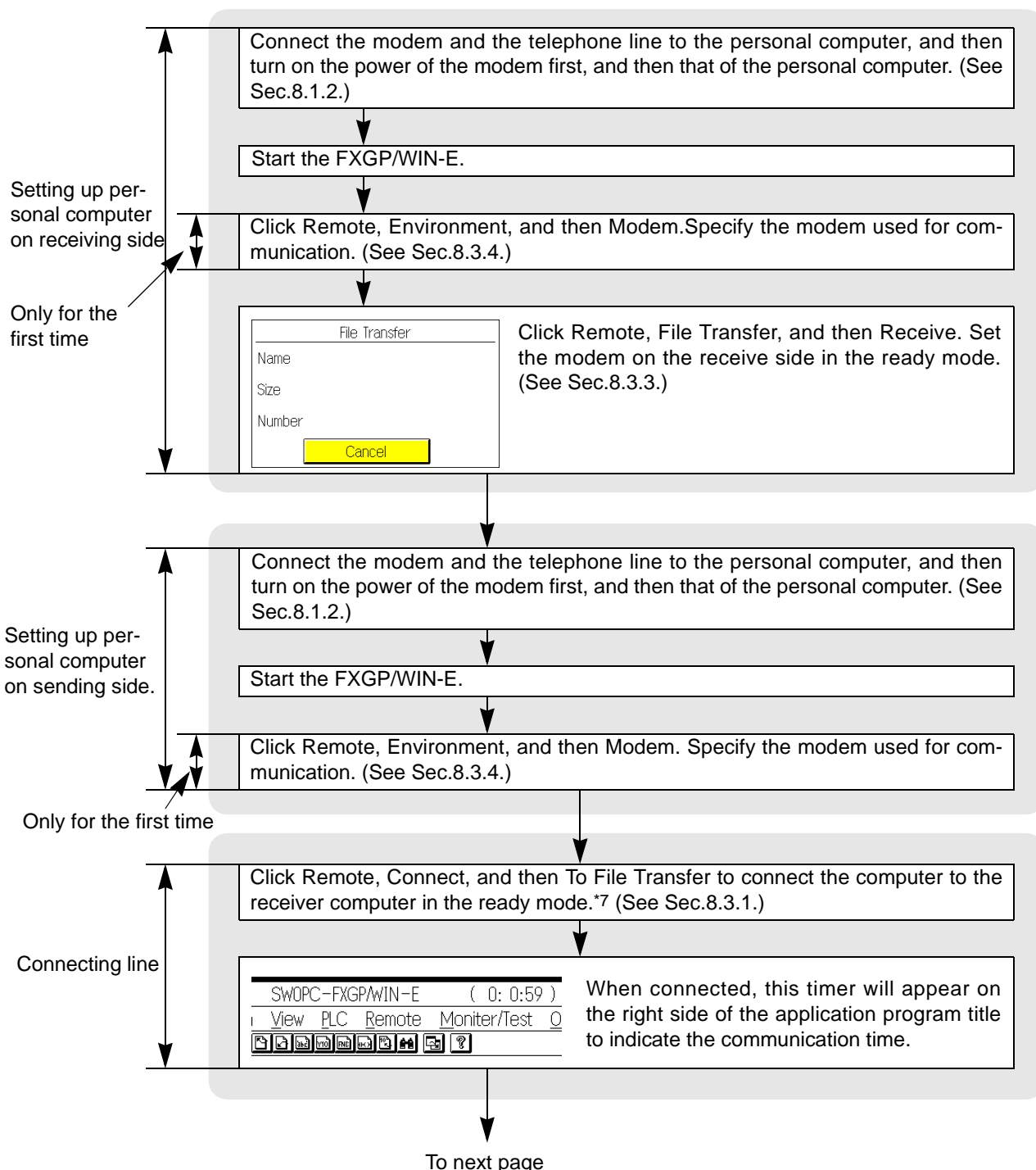

*7: Be sure to click To File Transfer to connect to the receiver computer. If you click To PLC, the line will not be connected to the computer.

Sequentially click Remote, File Transfer, and then Transmit. Select files you would like to transmit, and then click the OK button.

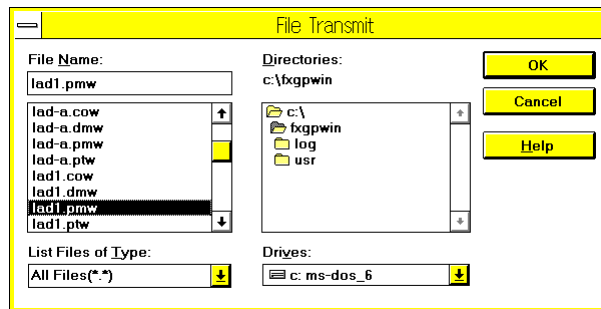

Selection of two or more files:

- Shift + clicking mouse (for selection of continuous files)
- Ctrl + clicking mouse (for selection of separate files)

(See Sec.8.3.3.)

Specify a directory of the receiver computer to clarify the file sending destination, and then click the OK button.

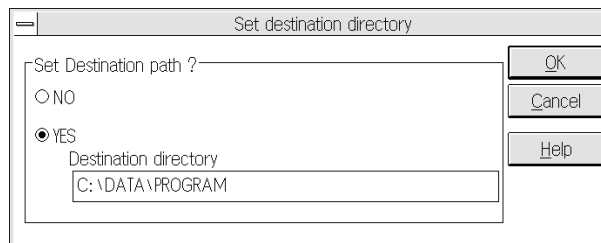

- If you select NO, the files will be stored in the sub-directory FILE of the FXGP/WIN-E on the receiving side.
- If you select YES, enter the full directory name in the Destination Directory field. If you specify a non-existing directory, the confirmation message "Create a new directory?" will appear on the display. If you select YES, a sub-directory will be created in the personal computer on the receiving side. If you select NO, file transfer will be canceled, and the telephone line will be disconnected.

(See Sec.8.3.3.)

To next page

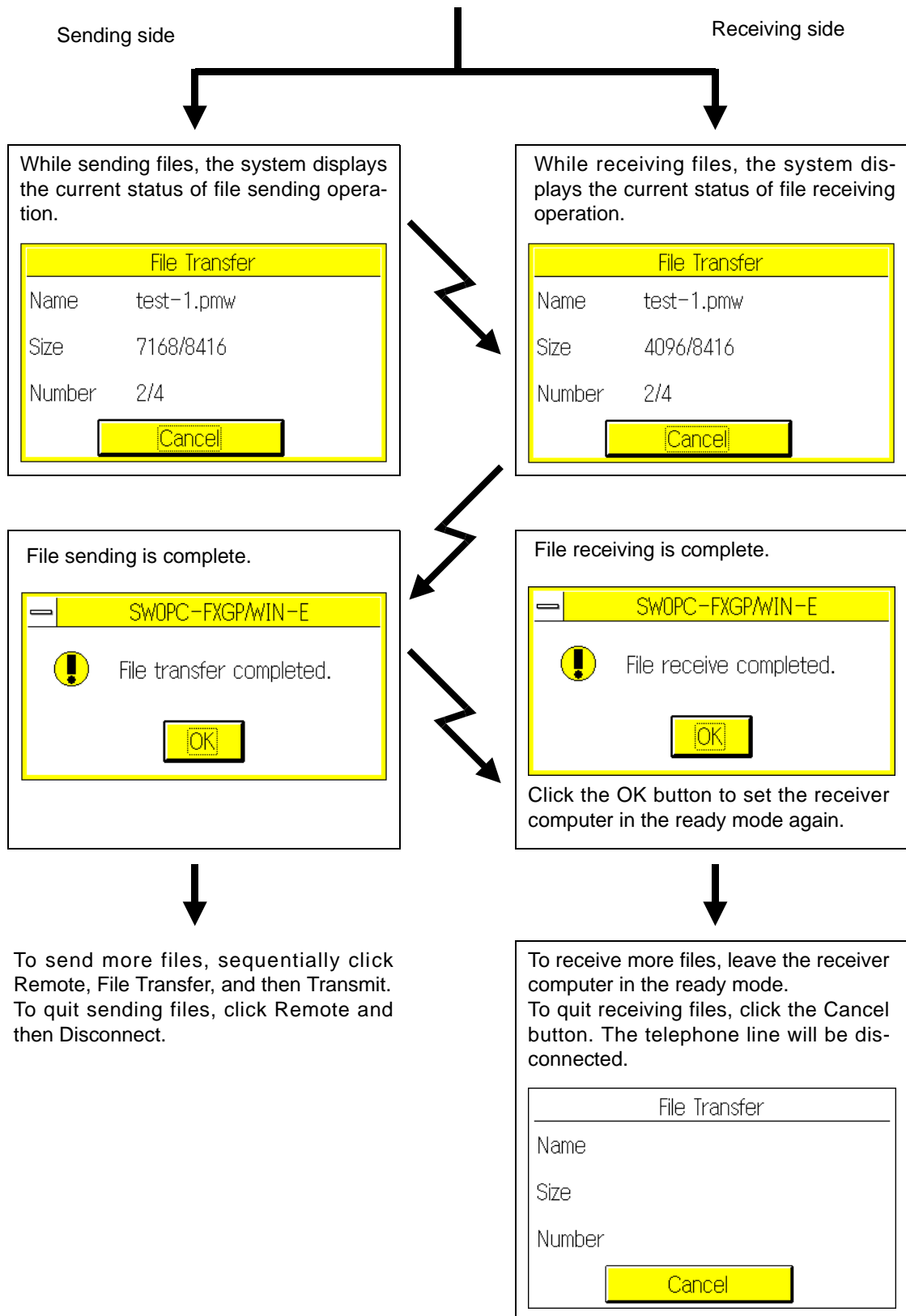

8.3 Functions on Remote Menu

8.3.1 Connect

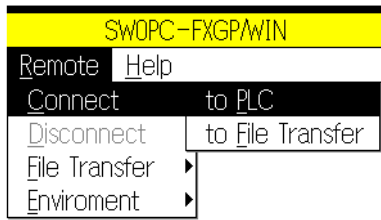

Connects the personal computer to the programmable controller through the telephone line to enable remote access to the programmable controller. You can store and edit the data on the remote station (programmable controller).

Connects the personal computer to the receiver computer to enable file transfer between computers. You can store and edit the data on the remote station (receiver computer).

Line connection screen

Click To PLC and then To File Transfer. The following line connection screen will appear on the display. This screen is common to both commands TO PLC and TO File Transfer, and the data edited on this screen will be controlled in the same way by both commands. The transfer speed between the personal computer and the modem depends on the specified command; To PLC or To File Transfer. For this reason, select the right command, and then click the Connect button. If a wrong connection command is selected for line connection, a communication error will occur during remote access to the programmable controller or during file transfer between computers.

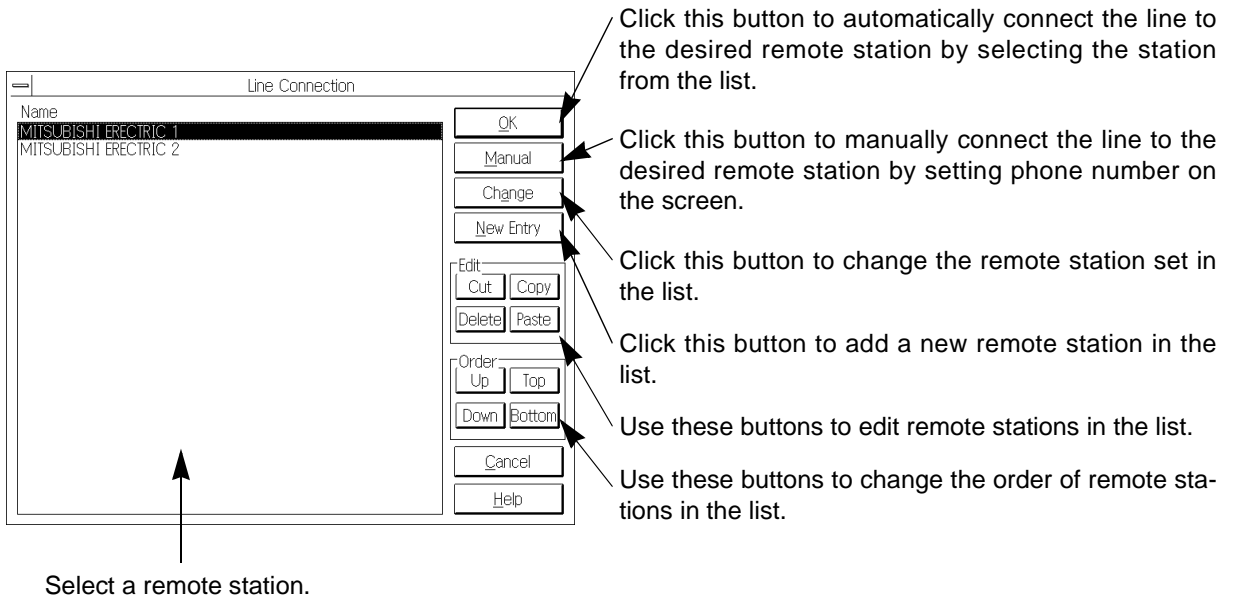

- Click this button to automatically connect the line to the desired remote station by selecting the station from the list.
- Click this button to manually connect the line to the desired remote station by setting phone number on the screen.
- Click this button to change the remote station set in the list.
- Click this button to add a new remote station in the list.
- Use these buttons to edit remote stations in the list.
- Use these buttons to change the order of remote stations in the list.

Select a remote station.

Line connection procedure (connection to remote station stored in the list)

Follow the procedure below to connect the telephone line to a remote station stored in the list.

- 1) Select Remote and then Connect. After that, select To PLC or To File Transfer depending on your purpose.
- 2) Click a remote station in the list to specify the station.
- 3) Click Yes.
- 4) The confirmation message "Connect to remote station?" will appear on the display. Select Yes.
- 5) The modem calls the remote station to connect the personal computer to the remote station.

Line connection procedure (connection to non-stored remote station)

Follow the procedure below to connect the telephone line to the desired remote station by directly entering the phone number in the Manual Connection dialog box.

The data entered in the Manual Connection dialog box will not be stored in the list, but will be logged in the communication log file.

- 1) Select Remote and then Connect. After that, select To PLC or To File Transfer depending on your purpose.
- 2) Click Manual.
- 3) The Manual Connection dialog box will appear on the display. Enter data in this dialog box.

Annotations for the Manual Connection dialog box:

- Enter the name in this box. The name will be logged in the communication log file as the remote station.
- Enter the phone number in this box. The modem will call the phone number.
- Click this button to connect the telephone line to the specified remote station.
- Set data in these boxes if necessary.

For a detailed description of data items in this dialog box, refer to "Storing new remote station" described later.

- 4) Click the OK button.
- 5) The confirmation message "Connect to remote station?" will appear on the display. Select Yes.
- 6) The modem will call the specified remote station to connect the personal computer to the remote station.

Storing new remote station

Follow the procedure below to connect the telephone line to the remote station non-stored in the list.

- 1) Select Remote and then Connect. After that, select To PLC or To File Transfer depending on your purpose.
- 2) Click New Entry.
- 3) The Edit Connection Data dialog box will appear on the display. Enter data in this dialog box.

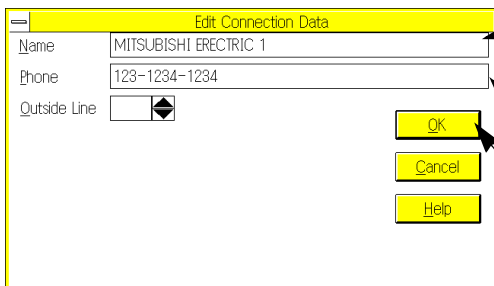

Enter the name of a remote station in this box. You can use up to 64 characters to set the name of a remote station, however the number of characters displayed in this box is limited.

Enter the phone number of the remote station in this box.

Click this button to store the set data and exit from this screen.

Enter a numeric value in the Outside Line box to specify the extension number. The numeric values you can enter in this box are from 0 to 9. Enter data in this box if you have to call an extension number, such as "0 + phone number". Enter null data in this box if it is not necessary to specify the extension number.

Enter data in the Daytime, Evening, and Nighttime boxes to clarify the telephone charges. Consult the telephone book to check how long you can call with 10 yen, and enter the time in seconds in the corresponding box.

The telephone charges will be logged in the log file. If it is not necessary to display the telephone charges, do not enter any data in these boxes.

Daytime: 8: 00 a.m. to 7: 00 p.m.

Evening: 7: 00 p.m. to 11: 00 p.m.

Nighttime: 11: 00 p.m. to 8: 00 a.m. of next day

- 4) Click the OK button.
- 5) Check the data set in the dialog box.
- 6) Click the OK button.
- 7) The confirmation message "Connect to remote station?" will appear on the display. Select Yes to connect the line to the specified remote station. Select No not to connect the line.
- 8) The new remote station is now stored in the list.



To store new data or modified data, be sure to follow steps 6) and 7) after entering data in the dialog box. To erase the data set in the dialog box after following steps 1) through 5), click the Cancel button or close the dialog box. The data you entered will be erased, and the data currently stored will not be modified.

Changing remote station data

Follow the procedure below to change the remote station data stored in the list:

- 1) Select Remote and then Connect. After that, select To PLC or To File Transfer depending on your purpose.
- 2) Click a remote station you would like to change.
- 3) Click the Change button.
- 4) Follow step 3 and subsequent steps described in "Storing new remote station" to change the remote station data.

Copying or deleting destination data

- Follow the procedure below to create another remote station using a remote station data stored in the list.
 - 1) Select Remote and then Connect. After that, select To PLC or To File Transfer depending on your purpose.
 - 2) Click a remote station you would like to copy or delete.
 - 3) Click the Copy button. (The data will not be deleted from the currently-displayed position.)
Click the Cut button. (The data will be deleted from the currently- displayed position.)
 - 4) Click the Paste button.
 - 5) The copied or cut data will be pasted at the end line of the list.
 - 6) Follow the procedure described in "Changing remote station data" to change the pasted data.
- Follow the procedure below to delete a remote station data from the list.
 - 1) Click a remote station you would like to delete.
 - 2) Click the Delete button.
 - 3) Click the OK button. The confirmation message "Connect to remote station?" will appear on the display. Select No.



If you click the Cancel button in place of the OK button, or if you close the dialog box without clicking the OK button, the specified remote station will not be deleted.

Changing remote station order

Follow the procedure below to change the remote station order in the list:

- 1) Click a remote station in the list to change its position in the list.
- 2) Click the Up, Down, Top, or Bottom button to move the remote station data to the desired position.
- 3) Click the OK button. The confirmation message "Connect to remote station?" will appear on the display. Select No.



If you click the Cancel button in place of the OK button, or if you close the dialog box without clicking the OK button, the specified remote station will not be deleted.

8.3.2 Disconnect

Use this function to disconnect the telephone line on the sending side.

If a communication or operation error occurs, or if you quit the FXGP/WIN-E, the telephone line will be automatically disconnected. To manually disconnect the telephone line, click Disconnect.

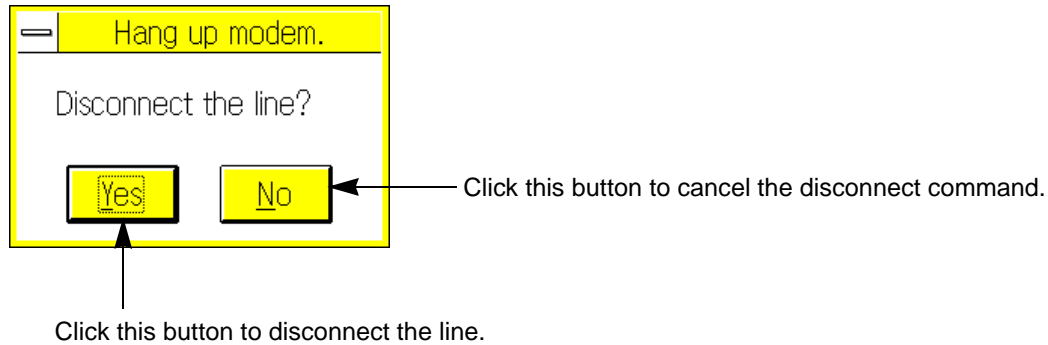

To disconnect the telephone line on the receiving side in the file transfer mode, click Cancel in the To File Transfer dialog box.



How to disconnect the line after abnormal end of Windows or FXGP/WIN-E:

If abnormal end of the Windows or FXGP/WIN-E occurs, turn off the power of the modem to disconnect the telephone line.

If abnormal end of software occurs, the personal computer cannot control the telephone line, therefore the line will not be disconnected automatically.

8.3.3 File transfer

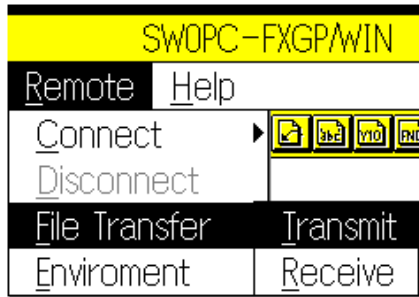

Use this command to transfer files to the receiver computer in the ready mode.

Use this command to set the personal computer on the receiving side in the ready mode.

Transmit

When the telephone line is connected, sequentially click Remote, File Transfer, and then Transmit.

- 1) Select files you would like to send.

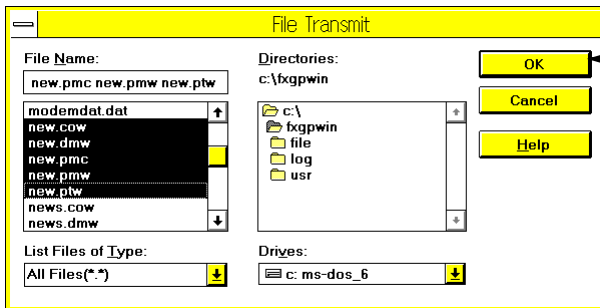

Select files, and then click the OK button. The screen shown in step 2) will appear on the display.

Selection of two or more files:

- Shift + clicking mouse (for selection of continuous files)
- Ctrl + clicking mouse (for selection of separate files)

Files that can be sent: Data files created by FXGP/WIN-E and other general files

- 2) Specify a directory of the receiver computer to send files to the specified directory.

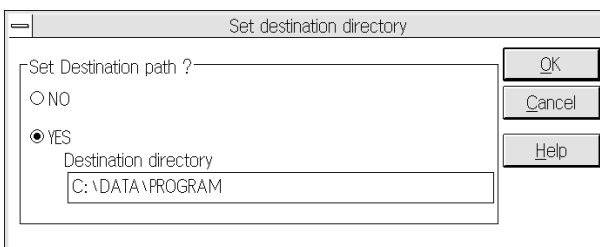

Click this button to send files.

- If you select NO, the files will be stored in the sub-directory FILE of the FXGP/WIN-E on the receiving side.
- If you select YES, enter the full directory name in the Destination Directory field. If you specify a non-existing directory, the confirmation message "Create a new directory?" will appear on the display. If you select YES, a sub- directory will be created in the personal computer on the receiving side. If you select NO, file transfer will be canceled, and the telephone line will be disconnected.

For a detailed description of file transfer procedure, refer to Sec.8.2.2.

Receive

Sequentially click Remote, File Transfer, and then Receive.

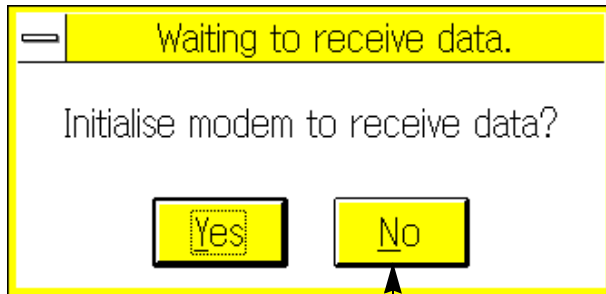

Click this button not to set the receiving side in the ready mode.

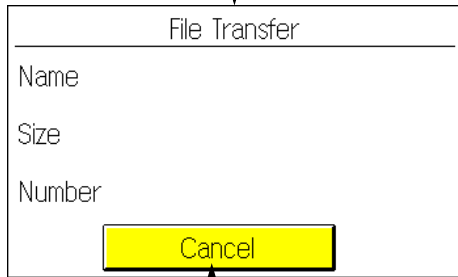

Click this button to cancel file transfer. The telephone line will be disconnected.

When files are sent from the personal computer on the sending side, the personal computer in the ready mode on the receiving side will store the files in the specified directory. For a detailed description of file transfer procedure, refer to Sec.8.2.2.

8.3.4 Environment → Modem

Specify and store a modem to be connected to the personal computer.
 To specify a modem, sequentially click Remote, Environment, and then Modem.

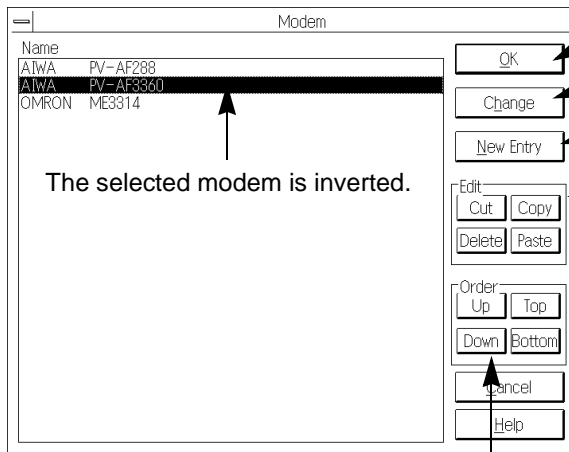

Use these buttons to change the position of the selected modem data in the list.

- Click this button at the completion of setting.
- Click this button to change the selected data.
- Click this button to store a new modem.
- Cut button : Temporarily stores the modem data you selected while erasing the data from the currently-displayed position.
- Copy button : Temporarily stores the modem data you selected without erasing the data from the currently-displayed position.
- Paste button : Pastes the temporarily-stored modem data at the end line of the list.
- Delete button: Deletes the modem data you selected.

Selecting modem

Follow the procedure below to select the modem used for telephone line connection:

- 1) Click the modem name in the list. The modem name will be inverted.
- 2) Click the OK button.

Storing new modem

Follow the procedure below to store a new modem in the list.

- 1) Click the New Entry button.
- 2) Enter data in the modem storage screen.

Enter the modem name to be stored in the list. Up to 40 characters can be used for the modem name.

Enter the AT command to initialize the modem. (For a detailed description, refer to the next page.)

Click this button to store the set data and close this window.

Set the type of the telephone line.

Use numeric values 0 to 9 to set the number of re-dialing times.

Use numeric values 0 to 999 to set the re-dialing intervals.

- 3) Click the OK button.
- 4) Click the OK button in the Modem dialog box.



If you click the Cancel button in place of the OK button, or if you close the dialog box without clicking the OK button, the set data will be erased.

Initialize command setting:

Use the AT command developed by Heiz in the U.S. to initialize the modem.

For a detailed description of the AT command, refer to the operation manual of your modem.

The AT command stored in this software sets the modem as shown in the table below.

The table, however, shows an example. The set items and data depends on the modem type. For the set items and data, therefore, refer to the operation manual of your modem.

Set item	PV-AF288(AIWA) ATE0S0=2Q0V1&M4¥J0 ¥Q0	PV-AF3360(AIWA) ATE0S0=2Q0V1&M4¥J0 ¥Q0	ME3314(OMRON) ATE0S0=2Q0V1S15=8& H0&R1
Command echo setting	E0 (not set)	E0 (not set)	E0 (not set)
Number of calls set for automatic connection	S0=2 (twice)	S0=2 (twice)	S0=2 (twice)
Displaying result code	Q0 (displayed)	Q0 (displayed)	Q0 (displayed)
Type of result code	V1(characters, words)	V1(characters, words)	V1(characters, words)
Communication mode	&M4(MNP auto)	&M4(MNP auto)	S15=8(V,42bis)
Terminal speed fixed mode	¥J0(fixed)	¥J0(fixed)	—
Sent data flow control	—	—	&H0(not set)
Terminal flow control method	¥Q0(not set)	¥Q0(not set)	&R1(not set)
Initialize to factory-set value	&F(The FXGP/WIN-E will output the above AT command after outputting AT&F.)		

Changing set modem data

Follow the procedure below to change the modem data stored in the list:

- 1) Click the modem name to change the modem data.
- 2) Click the Change button.
- 3) Follow step 2) and the subsequent steps described in "Storing new modem" to change the modem data.

Copying or deleting set data

- Follow the procedure below to create another modem data using a modem data stored in the list:
 - 1) Click a modem you would like to copy or delete.
 - 2) Click the Copy button. (The data will not be deleted from the currently-displayed position.)
Click the Cut button. (The data will be deleted from the currently- displayed position.)
 - 3) Click the Paste button.
 - 4) The copied or cut data will be pasted at the end line of the list.
 - 5) Follow the procedure described in "Changing set modem data" to change the pasted data.
- To delete a modem data from the list, select a modem from the list, and then click the Delete button. After that, click the OK button.



If you click the Cancel button in place of the OK button, or if you close the dialog box without clicking the OK button, the specified modem data will not be deleted.

Changing modem order

Follow the procedure below to change the modem order in the list:

- 1) Click a modem in the list to change the position in the list.
- 2) Click the Up, Down, Top, or Bottom button to move the specified modem data to the desired position in the list.
- 3) Click the OK button.



If you click the Cancel button in place of the OK button, or if you close the dialog box without clicking the OK button, the modem position will not be changed.

8.3.5 Environment → Logging File

Use the Logging File command to specify whether the communication log file should be output. Sequentially click Remote, Environment, and then Logging File.

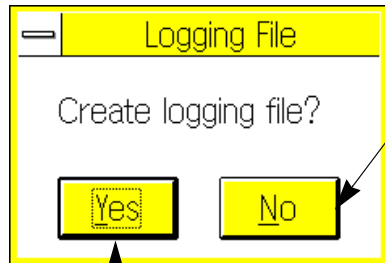

The FXGP/WIN-E will automatically output the log file. To temporarily stop outputting of the log file, select No in the log file output dialog box. This No command will be valid until you quit the FXGP/WIN-E or cancel the No command. When the FXGP/WIN-E is activated next time, the log file will be output again.

After temporarily stopping the output, select Yes to output the log file again.

The log file will be stored in the sub-directory LOG of the FXGP/WIN-E installed directory (initial value = \FXGPWIN). The format of log file is shown below:

File name:

97 07 10. LOG
year, month, day

Logged data:

```
Connect  97/ 07/ 18   15: 10: 21
Name     ABCDEFG
Phone    123-123-1234
Disconnect 97/ 07/ 18   15: 29: 15
Time     00: 18: 54
```

If the line is connected two or more times in one day, the communication data will be sequentially added in the same log file.

Communication data will be logged in text files, therefore you can look up these files using the memo pad of Windows.

8.4 Data Setting on Programmable Controller Side for Remote Access

To access to the remote FX2N,FX2NC programmable controller, set the parameters for the modem, and set communication data for the special data register.

For these settings, use the following programming software that enables modem setting for the FX2N programmable controller:

- FX-PCS/WIN-E, version 1.00 or above (for Windows)

Main setting

- 1) Reads out the program from the FX2N,FX2NC programmable controller to the peripheral unit.
- 2) Activate the programming software, and click PLC's Mode Setting to select the modem used for communication.

Example: Modem setting using FXGP/ WIN (See Sec.5.8.4.)

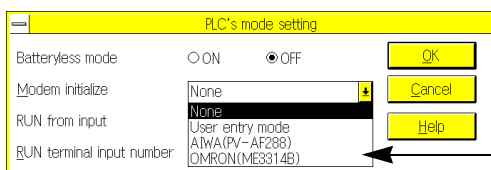

Select a modem from the Modem Initialize pull-down menu.

If no modem is stored, click User Entry Mode, and set the initialize command for the modem.

- 3) Set the D8120 (communication format) value to zero. The D8120 is one of the special data registers of the FX2N,FX2NC programmable controller.

If the current value of the D8120 is "0":

It is not necessary to rewrite the D8120 value. Go to the next step.

If the D8120 value is written in the sequence program:

Change the program of the D8120 as follows so that the current value of the D8120 is set to "0".

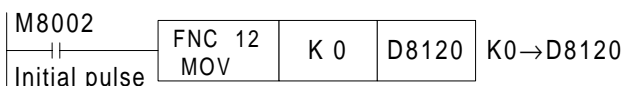

If communication conditions are set by the parameters of the peripheral unit:

If the communication conditions are set by the parameters of the peripheral unit, the set communication conditions will be written in the D8120 at power-on of the programmable controller. Clear these parameter-set communication conditions using the peripheral unit.

Use the following programming software to clear the communication conditions:

- FX-PCS/WIN-E
Click Option and then Serial Setting (Parameter). The Serial Setting (Parameter) dialog box will appear on the display. Click the Clear command in this dialog box.
- If you use another programming software to clear the parameters, follow the procedure below:
 - a) Store the parameter data currently set.
 - b) Clear all the parameters.
 - c) Excluding the Serial Setting, set the parameters and keyword to specify the communication conditions.
 - d) Click PLC's Mode Setting, and set the modem as described in step 2).
- 4) Write all the programs and parameters for the FX2N,FX2NC programmable controller.
- 5) If the sequence programs are changed by following step 3), click RUN and then STOP to stop the programmable controller, and then reset the current values of the D8120 to zero.

Setting user setting mode

If you select the User Setting Mode from the Modem Initialize pull-down menu (see step 2) of "Main setting"), store the initialize commands optimum for the modem as described below:

Initialize command format:

Use the AT command developed by Heiz in the U.S.
The general format of this command is shown below:

A	T	command+parameter	command+parameter	command+parameter	CR	LF
---	---	-------------------	-------------------	-------------------	-------	----	----

For a detailed description of the AT command, refer to the operation manual of your modem.

Storing AT command in programmable controller:

If you select User Setting Mode in the PLC's Mode Setting dialog box as described before, the FX2N programmable controller will send the AT&F command (command for resetting to factory-set values) and then the D1000 through D1059 data (modem initialize commands) to the modem via the RS-232C communication adapter/board at power-on of the programmable controller.

To use the user-set modem initialize commands, previously write the modem initialize commands in data registers D1000 through D1059 using the current value modify function of the peripheral unit or using the sequence program.

Examples of modem initialize commands: ATE0S0 = 2Q1& D0& M4¥Q0¥JO& W

Register number	ASCII code	Hexadecimal number	Register number	ASCII code	Hexadecimal number
D1000	A	41	D1013	&	26
D1001	T	54	D1014	M	4D
D1002	E	45	D1015	4	34
D1003	0	30	D1016	¥	5C
D1004	S	53	D1017	Q	51
D1005	0	30	D1018	0	30
D1006	=	3D	D1019	¥	5C
D1007	2	32	D1020	J	4A
D1008	Q	51	D1021	0	30
D1009	1	31	D1022	&	26
D1010	&	26	D1023	W	57
D1011	D	44	D1024	CR	0D
D1012	0	30	D1025	LF	0A

Up to 60 points of user-set initialize commands can be read out sequentially from the D1000 to D1059. If "00" is read out, reading out of initialize commands will be stopped.

When you create sequence programs, check that the data register area used for the general sequence programs are not the area for these modem initialize commands.

Description of modem setting data previously stored:

The modem setting conditions of the AT command previously stored in the programmable controller are shown below.

The modem setting conditions shown below are reference conditions. Actually-set conditions depend on the modem. Please refer to the operation manual of your modem.

Setting item	PV-AF288(AIWA) ATE0S0=2Q1&D0&M5 ¥Q0¥J0&W	ME3314(OMRON)*8 ATE0S0=2Q1&D0&H0& R1S15=8&W
Command echo setting	E0(not set)	E0(not set)
Number of calls set for automatic connection	S0=2(twice)	S0=2(twice)
Displaying result code	Q1(not displayed)	Q1(not displayed)
DTR control	&D0(always ON)	&D0(always ON)
Communication mode	&M5(V,42bis)	S15=8(V,42bis)
Terminal flow control method	¥Q0(not set)	&R1(not set)
Sent data flow control	—	&H0(not set)
Terminal speed fixed mode	¥J0(fixed)	—
Writing in nonvolatile memory	&W	&W

*8 : The AT command setting function for the ME3314 (OMRON) is added to the FX2N programmable controller version 2.01 or above (manufacturing number 78**** or above).

Programming data

For a detailed description of the programmable controller and sequence programs, refer to the following documents:

MEMO

1	Introduction
2	Installing FXGP/WIN-E
3	Main Operation
4	Work Windows and their Functions
5	Menu Bar Commands and their Functions
6	Creating Ladder and Instruction Programs
7	Creating SFC Programs
8	Remote Maintenance Using Telephone Line
	Appendix

Error Code Tables

Error Detection Device	Stored Error Number	Associated Meaning	Action
D8062 PC/HPP communications error	0000	No error	Check the cable connection between the programming device and the programmable controller
	6201	Parity/overrun/framing error	
	6202	Communications character error	
	6203	Communication data sum check error	
	6204	Data format error	
	6205	Command error	

Error Detection Device	Stored Error Number	Associated Meaning	Note
D8063 ***ADP 485 network and 232ADP communica- tions errors (These apply ONLY when the ***ADP units are used)	0000	No error	Special note regard- ing the 485 network: Because these errors are not transmitted through the network, they must be moni- tored by the unit acting as Master to the net- work
	6301	Parity/overrun/framing error	
	6302-6304	Reserved	
	6305	Command error-received command other than GW (global when station number was FF)	
	6306	Monitor time over (watchdog timer error)	

Error Detection Device	Stored Error Number	Associated Meaning	Note
D8063 Parallel link errors (these apply ONLY when the parallel link modules are used on FX and FX2c units)	0000	No error	Check both power and communications con- nections
	6301	Parity/overrun/framing error	
	6302	Communications character error	
	6303	Communication data sum check error	
	6304	Data format error	
	6305	Command error	
	6306	Watchdog timer error	

Error Detection Device	Stored Error Number	Associated Meaning	Action
D8064 Parameter error	0000	No error	STOP the programmable controller, select the parameter mode, set the correct data
	6401	Program sum check error	
	6402	Memory capacity setting error	
	6403	Latched device area setting error	
	6404	Comment area setting error	
	6405	File register area setting error	
	6406-6408	Reserved	
	6409	Other setting error	

Error Detection Device	Stored Error Number	Associated Meaning	Action
D8065 Syntax error	0000	No error	During programming, each instruction is checked as it is entered. If a syntax error is detected, re-enter the instruction correctly
	6501	Incorrect instruction/device symbol/device number combination	
	6502	No timer or counter coil before setting value	
	6503	1) No setting value following either a timer or a counter coil 2) Insufficient number of operands for an applied instruction	
	6504	1) The same label number is used more than once 2) The same interrupt input or high speed counter input is used more than once	
	6505	Device number is outside the allowable range	
	6506-6508	Reserved	
	6509	Other setting error	

Error Detection Device	Stored Error Number	Associated Meaning	Action
D8066 Circuit error	0000	No error	A circuit error occurs if a combination of instructions is incorrect or badly specified. Select programming mode and correct the identified error.
	6601	LD and LDI is used continuously 9 or more times in succession	
	6602	1) No LD/LDI instruction. Unauthorized use of the LD/LDI, AND/ANI instructions 2) The following instructions are not connected to the active bus line: STL, RET, MCR, (P)ointer, (I)nterrupt, EI, DI, SRET, IRET, FOR, NEXT, FEND and END 3) When MPP is missing	
	6603	MPS is used continuously more than 12 times	
	6604	Unauthorized use of the MPS/MRD/MPP instructions	
	6605	1) A single STL branch drives 9 or more parallel circuits 2) MC/MCR or (I)nterrupts are designated within an STL state 3) RET has not been designated or is designated out of an STL state	
	6606	1) No (P)ointer/(I)nterrupt 2) No SRET/IRET 3) An (I)nterrupt/SRET or IRET has been designated within the main body of the program 4) STL/RET/MC or MCR have been designated within either a subroutine or an interrupt routine	
	6607	1) Unauthorized use of FOR-NEXT. 6 or more levels have been designated 2) The following instructions have been designated within a FOR-NEXT loop: STL/RET/MC/MCR/IRET/SRET/FEND or END	
	6608	1) Unauthorized MC/MCR relationship 2) Missing MCR N0 3) SRET/IRET or an (I)nterrupt has been designated within an MC/MCR block	
6609	Other error		

Error Detection Device	Stored Error Number	Associated Meaning	Action
D8067 Operation error	0000	No error	These error occur during the execution of an operation. When an operation error occurs, STOP the PC enter programming ode and correct the fault. Note: operation errors can occur even when the syntax or circuit design is correct, eg. D500Z is a valid statement within an FX PC. But if Z had a value of 100, the data register D600 would be attempted to be accessed. This will cause an operation error as there is no D600 device available.
	6701	1) No jump destination for CJ or CALL instructions 2) A label is designated in a block that comes after the END instruction 3) An independent label is designated within a FOR-NEXT loop or a sub-routine	
	6702	6 or more CALL instructions have been nested together	
	6703	3 or more interrupts have been nested together	
	6704	6 or more FOR-NEXT loops have been nested together	
	6705	An incompatible device has been specified as an operand for an applied instruction	
	6706	A device has been specified outside of the allowable range for an applied instruction operand	
	6707	A file register has been accessed which is outside of the users specified range	
	6708	FROM/TO instruction error	
	6709	Other error, i.e. missing IRE/SRET, unauthorized FOR-NEXT relationship	
	D8067 PID Operation error	6730	
6732		Input filter value α (α <0 or \geq 101)	
6733		Proportional gain KP (KP<0 or >32767)	
6734		Integral time constant TI (TI<0 or >32767)	
6735		Derivative gain KD (KD<0 or \geq 101)	
6736		Derivative time constant TD (TD<0 or >32767)	
6740		Sampling time TS is less than the program scan time.	Ts is set to program scan time - Execution will continue.
6742		Current value Δ exceeds its limits	Data affected resets to the nearest limit value. For all errors except 6745, this will either be a minimum of -32768 or a maximum of +32767.
6743		Calculated error exceeds its limits	
6744		Integral result exceeds its limits	
6745		Derivative gain over, or differential value exceeds allowable range	
6746		Derivative result exceeds its limits	Execution will continue.
6747		Total PID result exceeds its limits	

File converter

By using this file converter, a MELSEC MEDOC file (.TMP) can be converted into an FXGP/WIN-E file.

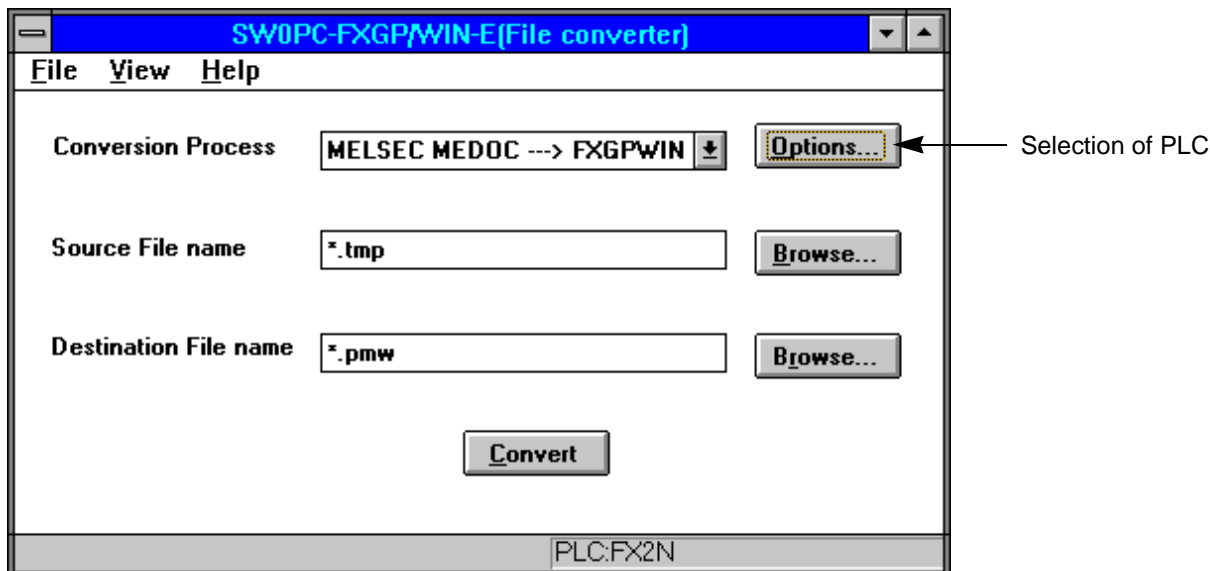

Listings for printout

- 1) "INSTR" and "PARAMETER" must always be selected in the printout menu of MELSEC MEDOC.
- 2) When the device names and the device comments should be converted, "NAME" must be selected in the printout menu of MELSEC MEDOC.
- 3) When the circuit comment is converted, "ONLY COM" must be selected in the printout menu of MELSEC MEDOC.
- 4) When the value of the data register is converted, "DWR" must be selected in the printout menu of MELSEC MEDOC.

File name

- 1) File names up to eight characters are allowed.
(Do not use the long file names of WINDOWS95)
- 2) The extension of the text file for MELSEC MEDOC should be "TMP".

Limitation and rule of the data when converting.

- 1) Device name conversion
NAME which exceeds eight characters are cut to eight characters.
Characters other than alphabet characters, numbers or the effective signs stated below are replaced with '_' (under bar).
(Effective sign: +*/= .? # \$ % & ; ; _)
- 2) Circuit comment
Up to 500 characters in total are converted when there are two or more comment lines for one circuit block.
- 3) Value of data register
When two or more sets of SETUP data of the data, link and file registers (DWR) are converted, only the last SETUP data can be converted.

Memo

Under no circumstances will Mitsubishi Electric be liable or responsible for any consequential damage that may arise as a result of the installation, use and/or programming of the products associated with this manual.

All examples and diagrams shown in this manual are intended as an aid to understanding the text, not to guarantee operation. Mitsubishi Electric will accept no responsibility for actual use of the product based on these illustrative examples.

Owing to the very great variety of possible applications, users must satisfy themselves as to the suitability of each specific application.

SOFTWARE MANUAL

FX-PCS/WIN-E



HEAD OFFICE: MITSUBISHI DENKI BLDG MARUNOUCHI TOKYO 100 TELEX: J24532 CABLE MELCO TOKYO
HIMEJI WORKS: 840, CHIYODA CHO, HIMEJI, JAPAN

Effective FEB.1999
Specifications are subject
to change without notice.

JY992D66501C
(MEE)