

worknc

www.worknc.com

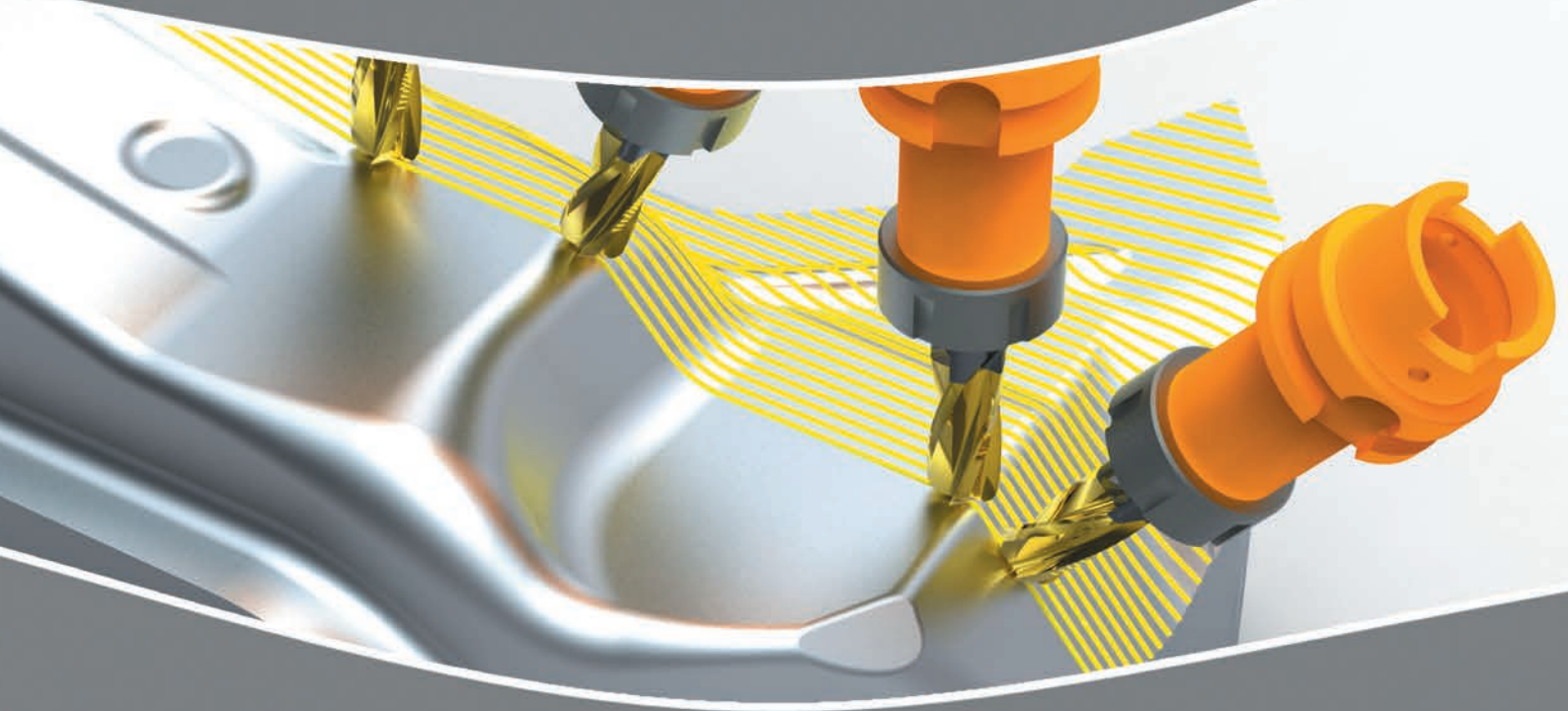

Automatic CAD/CAM
from 2D to 5-axis Machining

vero
Software

Automatic 2D to 5-axis Machining



WorkNC automated CAD/CAM software for 2 to 5 axis machining has been continuously developed since 1988 and is currently used by thousands of companies around the globe from a range of industries.

WorkNC is the closest system to “One Button CAM” with automated, efficient toolpaths bringing dramatic productivity gains through shorter machining times, longer tool life, improved surface finish and accuracy, better machine utilization, and fast and easy CNC programming.

WorkNC’s multi-threaded processing takes advantage of multi-core computers giving blisteringly fast calculation and processing times. Preparation times are also reduced thanks to predefined machining sequences and batch mode toolpath calculations.

> John Harvey of Harvey Precision says, “WorkNC’s parallel processing is a quantum leap in performance.”

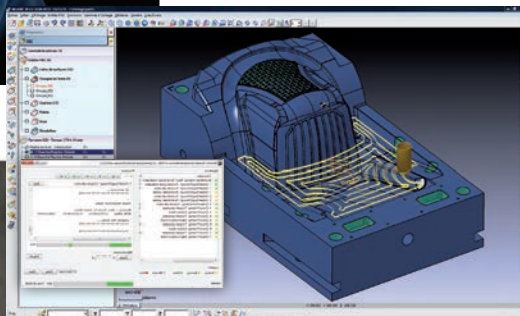

Multi-core Calculations

Roughing and re-roughing toolpaths in WorkNC enable large volumes of stock to be removed in a single pass with large depths of cut, while dynamic stock management gives it the sensitivity to work with small diameter tools too.

> Roy Thomas of Patterson Mold & Tool says, “Roughing operations take half the time to program and run 70% faster.”

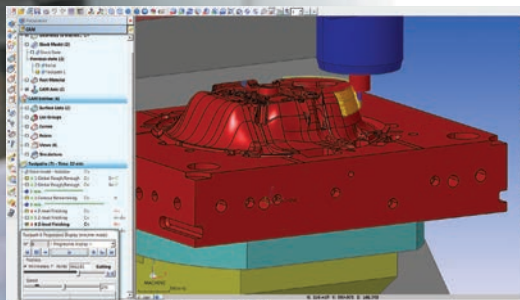

Collision Management

Toolpaths optimized for high speed machining make it easy to rapidly and safely cut the hardest materials, reducing the need for EDM.

> Hiroki Takama of Riken Forge says, “Direct machining of the die has eliminated EDM operations resulting in a dramatic 82% reduction in manufacturing time.”

Advanced collision detection and avoidance checks the tool, its holder, the machine tool itself, and the machine limits, to produce completely reliable toolpaths. It automatically splits the collision free and collided sections of the cutterpath. WorkNC is so reliable that many users maximize productivity through unattended, “lights out” machining.

WorkNC users include :

Virtually all of the world's automobile companies: Peugeot®, Citroen®, Renault®, Volkswagen®, Audi®, Mercedes Benz®, BMW®, Jaguar®, Rolls Royce®, Bentley® Ford®, General Motors®, Nissan® and Honda®; aerospace companies including Snecma® and Eurocopter®; household appliances manufacturers including Calor®, Miele®, and Whirlpool®; consumer electronics companies including Samsung® and Motorola® and a raft of mold, die and press tool companies including the multinational Arrk® Group.

WorkNC's dynamic stock management updates as machining progresses and supports any shape of cutter. The result is highly accurate remachining, constant tool loads and exceptionally reliable toolpaths.

> Darrel Gallier of C.A. Tooling says, "A block of 4140 tool steel can cost around \$50,000 and we typically machine away 60-70%, so the reliability we get with WorkNC is crucial."

WorkNC's finishing strategies generate safe and fast toolpaths for the most complex geometry automatically, resulting in outstanding surface finishes, shorter machining times and longer tool life.

> Mr Kazuya Fukushima of Shinkoh Mold Co. Ltd says – "WorkNC allows us to machine successfully with 0.2mm diameter tools 10.5mm long, which is a length to diameter ratio of 26, without deflection or damage."

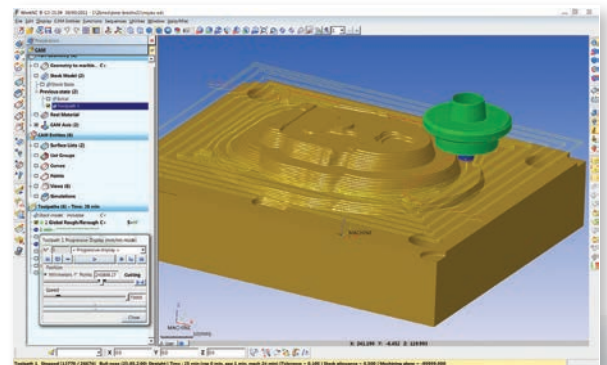

Roughing with Dynamic Stock Model Management

WorkNC can import model data from all the leading CAD packages and **can easily manipulate the largest files.**

> Jon Ingleby of Gordon Murray Design says, "The CAD interface is very reliable, and WorkNC is tolerant of small imperfections in the model, saving the considerable amount of time it can take to repair these."

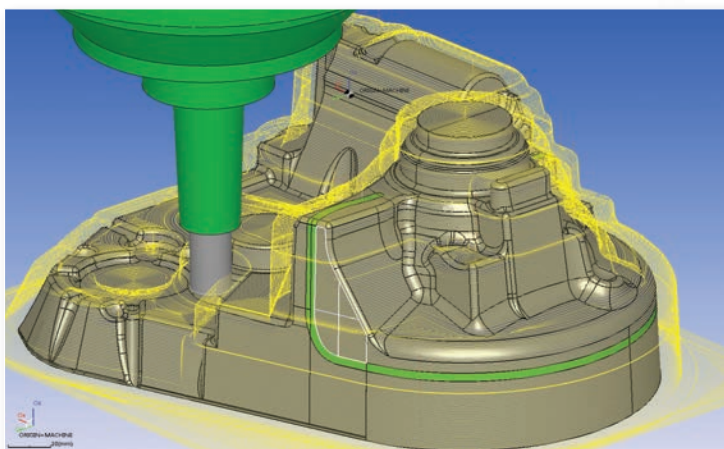

Global Finishing



Intuitive user interface, powerful CAD functionality and toolpath editing

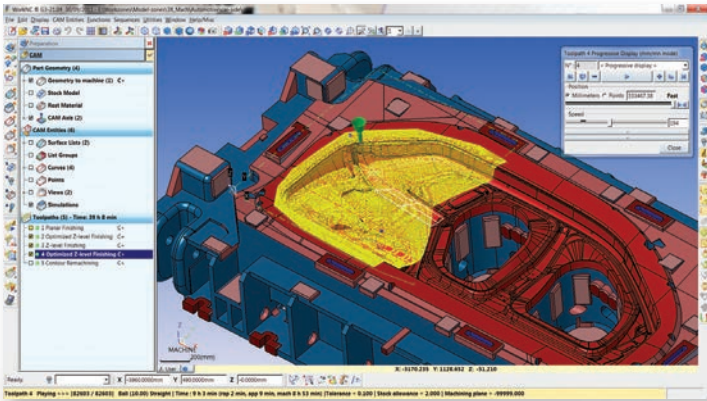

WorkNC's **intuitive GUI** enables users to become productive in the shortest possible time.

> Marvin Sims of Presrite Corporation says, "I was totally amazed at how easy it was to learn. Additionally, we get regular visits from SESCOI engineers and we take full advantage of extra training opportunities."

The intuitive operation and **automated machining strategies** make WorkNC ideal for use on the shop floor.

> Kevin Baker of Bentley Motors says, "Four modellers in the Styling Studio use the WorkNC seats in the workshop. Its ease of use makes their tasks much simpler and they have absolute confidence in the results it produces."

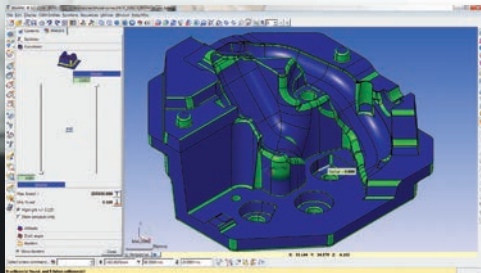

Minimum curvature analysis

Analysis tools simplify the interrogation of CAD data to check features such as draft angles and the smallest radius.

> Haruki Matsui of TOMCO Co Ltd says, "The analysis function color codes radii so we can select the right tools from the tool library, and the dynamic cross section and semi-transparent part views make it easy for us to examine complex components."

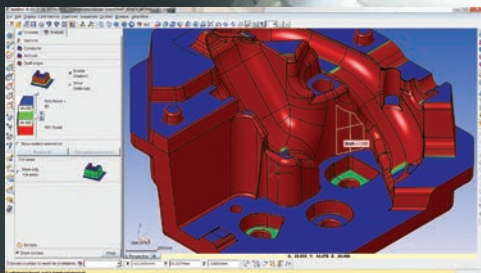

Draft angle analysis

WorkNC's **powerful graphical toolpath editor** enables users to quickly and intuitively modify the toolpath to suit their individual requirements from a single command.

> Ceyhun ÇINAR of Serdar Plastik says, "WorkNC's graphic toolpath editor is lightning fast."

Automatic 2-axis machining

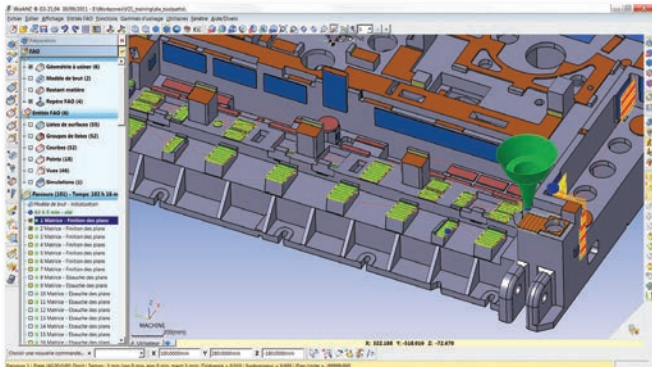
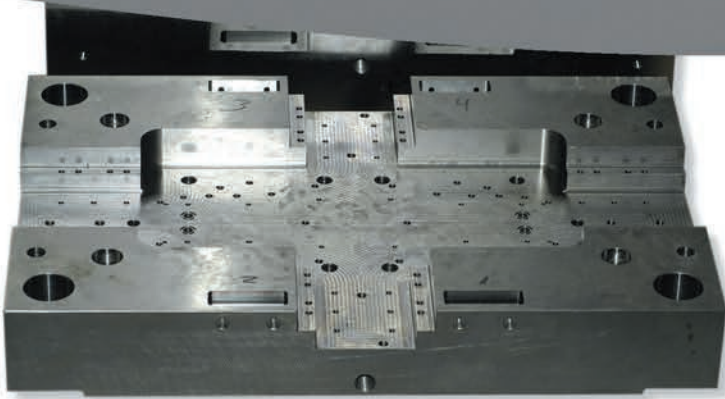

Automatic multi-face surfacing

Standard 2-Axis machining

Starting from 2D or 3D models created in WorkNC-CAD or from imported 2D or 3D CAD models, WorkNC automatically programs 3D models. For 2D geometry, powerful 2D curve machining options simplify and speed up the programming even where the geometry is damaged or intersecting. The advanced toolpaths which WorkNC produces are highly reliable, and result in short machining times and long tool life.

2D machining strategies:

- > Tangent to curve
- > Curve re-machining
- > On curve (engraving)
- > Pocketing
- > Rib machining
- > Facing
- > Drilling, tapping and point drilling

Feature Recognition

For parts with many holes, WorkNC's Feature Recognition automates drilling and boring operations and eliminates the possibility of human error.

The software identifies specific hole types formatted in the CAD model and automatically applies predefined and customized drilling, boring and tapping strategies. The resulting toolpaths produce consistent machining performance across the whole part and ensure positional accuracy, even for cross drilled holes.

- > Automatic recognition of cylindrical forms
- > Automatic feature creation to suit detected axes or angled planes
- > Predefined drilling sequence selection
- > Automatically generated drilling operations
- > Deep hole and intersecting hole drilling management

> Ed Busman of Walker Tool and Die says, "The return on investment from WorkNC Feature Recognition was immediate. Not only has it saved us many hours of work, it has also made our machine shop more productive and cut out many of the sources of error, greatly increasing the accuracy of our finished tools."

Interactive Drilling

WorkNC's interactive drilling functions allow users to select hole locations and sizes directly from the model topology. Complete drilling cycles are quickly built up from the intuitive interface, allowing users to easily generate reliable and effective drilling operations even for angled holes.

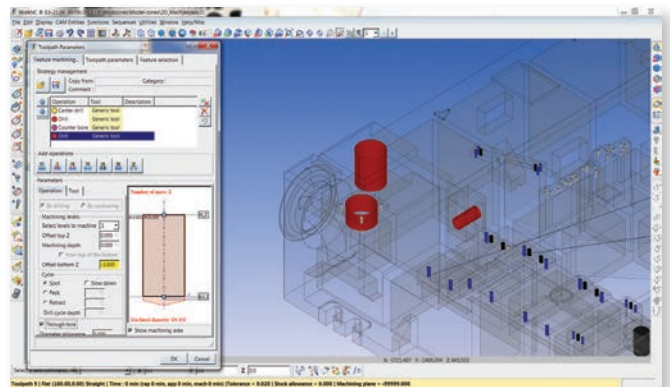

Automatic features detection

3 and 3+2 Axis Roughing, Re-Machining and Finishing

Highly Efficient Roughing Strategies

WorkNC's automated Roughing and Re-Roughing toolpaths enable engineers across the world to reliably and safely achieve unprecedented metal removal rates. Using its dynamic stock model management, the software's algorithms know exactly where material needs to be removed at any instant, keeping tool loads constant while checking for potential collisions and minimizing retract and wasted movements.

Parallel processing technology

Multi-threaded processing operates across WorkNC's toolpaths and Workzones, running on multiple cores simultaneously and producing speed improvements of up to ten times, allowing several toolpaths to be calculated at the same time to greatly reduce programming and calculation times.

Roughing and Re-Roughing strategies include :

- > Trochoidal movements when cutting with the full tool diameter
- > Localized retracts and corner smoothing for HSM
- > The ability to cut at large Z depths in a single pass to maximize metal removal and make the best use of the tooling
- > Flat surface machining across the complete part, automatically creating the correct 3+2 machining orientation for each of the multiple toolpaths
- > Spiral core roughing for a highly fluid and high speed tool trajectory
- > High volume roughing with a plunging action.
- > Batch processing of long toolpaths with integrated collision detection

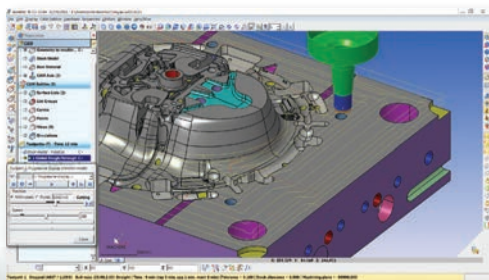

Global Roughing

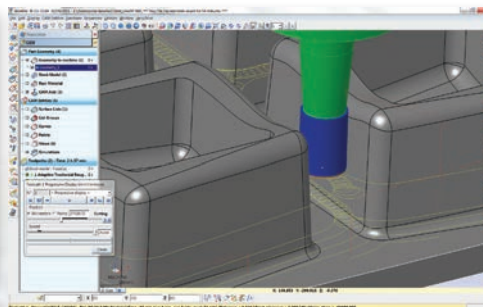

Trochoidal Roughing

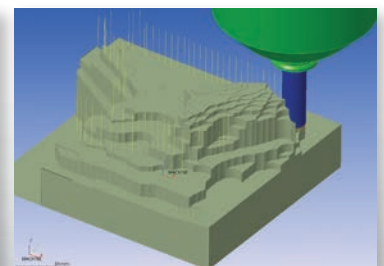

High Volume Roughing

High speed, accurate Finishing and Re-machining toolpaths

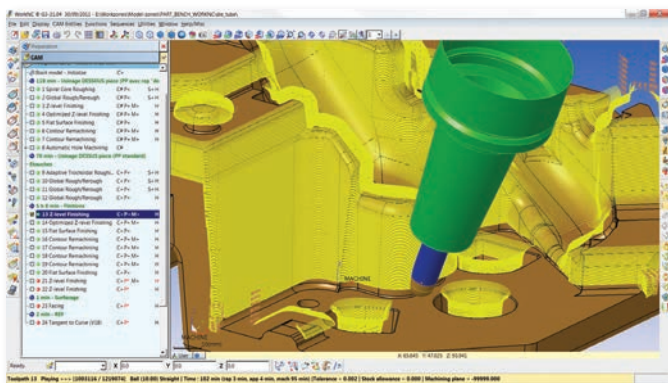

Automatic 5-Axis finishing

A raft of finishing and remachining strategies in WorkNC gives users the ability to easily tailor machining operations to suit their individual requirements. Coupled with the powerful graphical toolpath editor and the ability to create sets of knowledge based automatic cutting strategies, WorkNC will deliver extremely short programming times and greatly improved quality and productivity.

> Mark Gruic of Prospect Mold says, "The benefit of WorkNC to Prospect Mold is phenomenal, we monitor our machine utilization levels and we consistently spend 80% of our time cutting metal."

Rest material technology detects the remaining material, limiting unnecessary tool movement and enabling engineers to work successfully with the smallest and most fragile cutters while reducing overall machining times. Optimization for high speed machining includes helical approach paths, elimination of unnecessary retract moves, corner smoothing, and global finishing strategies which keep the tool in contact with the part. For even greater ease of use, 3D surfaces can be selected by simply rolling the mouse across them, ready for machining.

WorkNC supports special cutters of any shape, and takes these into account for subsequent rest machining operations. It is also able to machine undercut conditions and check for potential collisions as programming continues.

Visualization and verification of the toolpath allow engineers to see the proximity of cutters in real time so that they can fine tune the finished toolpath.

Finishing toolpaths include –

- > Global finishing for a continuous spiral toolpath across a contoured surface.
- > Planar finishing for shallow surfaces
- > Flat surface finishing
- > Z-level machining and optimized Z-Level machining for steep surfaces
- > Undercut remachining
- > Z level remachining
- > Contour remachining
- > 3D drive curve machining
- > Thin wall machining

> Mr Liu of Shandong Weifang Foton Mould Co. Ltd says, "We used WorkNC's machining strategies for roughing and finishing and the result was remarkable. Using the same parameters as we had on our old CAM system, the software solved our problems easily, producing smooth curves without any ripples or stripes, and a much brighter and higher quality surface finish straight off the machine."

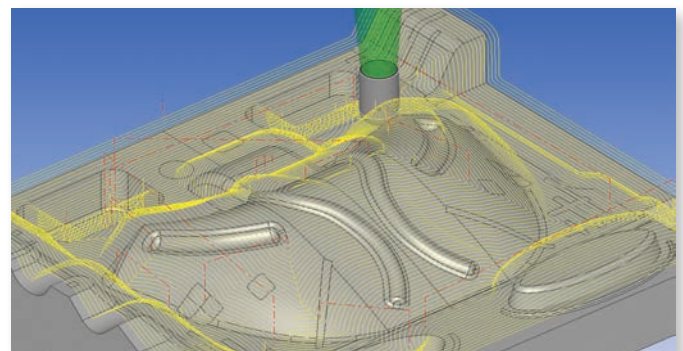

Finishing

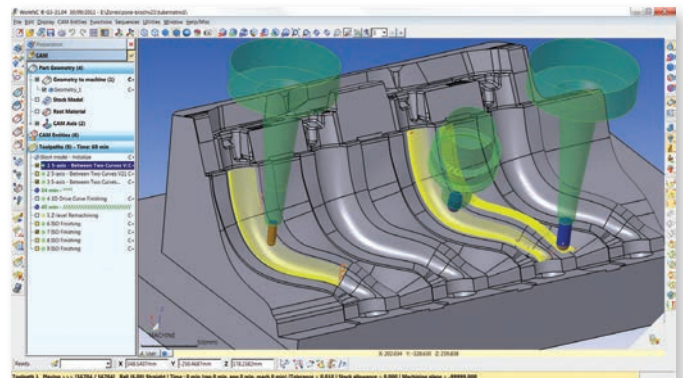

3 and 5-axis finishing strategies

Automatic 5-axis machining

From just six ergonomic dialogue boxes, engineers can automatically turn 3 and 3+2 axis machining paths into full 5-axis simultaneous toolpaths with WorkNC Auto 5. The ease of programming brings 5-axis machining well within the reach of every company by eliminating programming complexity and making it practical to carry out 5-axis programming on the shop floor.

The intelligent toolpaths are automatically and dynamically controlled to avoid collisions and to manage the rotation limits of each specific machine tool.

With WorkNC Auto 5, companies can benefit from smooth, fluid 5-axis toolpaths which enable the use of short rigid cutters, and allow more of the job to be finished in one setting.

Simultaneous 5-axis strategies

WorkNC also offers specialized 5-axis strategies for individual applications such as trimming, pocketing, blade and tube machining, impellers and laser cutting.

- > Rolling
- > Planar finishing
- > Pocketing
- > Blade machining
- > Laser cutting
- > Tube machining
- > Impeller machining
- > 3D curve machining
- > Groove machining
- > 5-axis drilling

> Roy Thomas of Patterson Mold & Tool says, "We use WorkNC's Auto 5 module exclusively for our 5-axis programming and we found it so easy to use that we did not need any training. Now around 25% of our work requires 5-axis machining and our 10 machinists use it every day in the workshop."

> Haruki Matsui of TOMCO Co Ltd says, "WorkNC is the best software we have for 3 and simultaneous 5-axis machining. Our engineers prefer it by far. It has definitely enabled us to win more business."

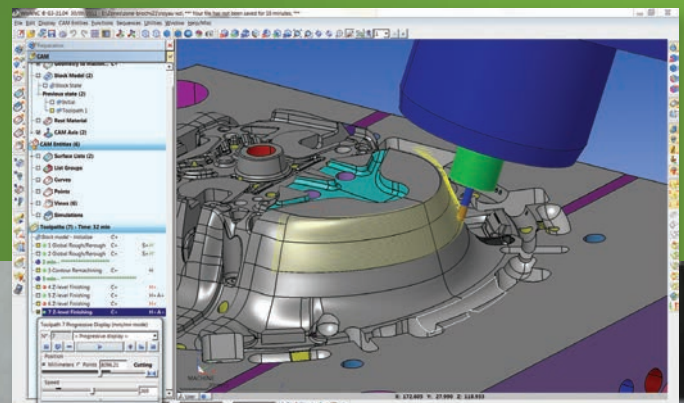

3 and 5-axis finishing strategies

Only a small training requirement for big productivity gains

Due to WorkNC's ease of use and numerous automatic features, the training time required is much shorter than for other CAD/CAM systems, even for 5-axis.

Check out the WorkNC machining videos on YouTube
 www.youtube.com/CADCAMexpert



Continuous development and service

From its inception in 1988, WorkNC has been developed as an automated CAD/CAM system. Continuous development, and many years of experience and expertise in CNC machining have enabled Vero to offer its clients leading edge technology. With WorkNC, thousands of companies are easily programming the most complex parts, achieving reduced machining times, and maximizing productivity through shopfloor and lights out machining.

Vero prides itself in the quality of its after sales service, working in partnership with its customers to optimize the efficient use of their CNC machinery through its worldwide customer support network.

The solution

Manufacturers around the world have put their trust in the quality, reliability and ease of use of WorkNC, one of the world's most widely used CAD/CAM systems. Vero Software constantly invests in quality, customer service, and research and development to provide its customers with cutting edge software technology.

 www.youtube.com/CADCAMexpert

 www.facebook/cadcamsoftware

 www.twitter/worknc

www.worknc.com



SESCOI USA INC.

2000 Town Center, Suite 1730
48075 Southfield - Michigan
USA
Tel. (+1)-248-351-9300
info@sescoi.com

SESCOI International UK Customer Services

PO Box 14562, Trinity Place,
Midland Drive, Sutton Coldfield
B73 9PP West Midlands
United Kingdom
Tel. 0844 561 7014
info@sescoi.co.uk

SESCOI FRANCE SAS

& SESCOI INTERNATIONAL SAS
Boulevard du Général de Gaulle
71009 Macon Cedex
France
Tel. (+33) (0)385216621
international@sescoi.fr

SESCOI GMBH

Schleussnerstraße 90-92
D-63263 Neu-Isenburg
Germany
Tel. (+49) (0) 6102-7144-0
info@sescoi.de

SESCOI IBERIA

C/ Narcis Monturiol,
2, Planta 4
08960 Sant Just Desvern
Barcelona
Spain
Tel. (+34).93.480.2455
info@sescoi.es

SESCOI SOUTH KOREA Branch Office

Room 608,
Baeksang Star Tower 2nd,
165, Gasan Digital 2-ro,
Geumcheon-gu,
153-714 Seoul
Korea
Tel. (+82).70.8282.5805
info@sescoi.co.kr

SESCOI CHINA

Suit.2010 No.69 Dongfang Rd.
Pudong New Area,
Shanghai 200120
China
Tel. (+86).21.58.30.37.19
info@sescoi.cn

SESCOI KK

Kamiyacho Plaza Bldg. 3F 4-1-14 Torano-
mon Minato-ku
Tokyo 105-0001
Japan
Tel. (+81).3.3578.0025
info@sescoi.co.jp

SESCOI INDIA SOLUTIONS PRIVATE LIMITED

Q - 401, 4th floor 244, Mayur Trade
Center,
Mumbai Pune Highway Chinchwad
Pune 411 019
India
Tel. (+91).20.46701586
india@sescoi.com

SESCOI BRASIL

Rua Paraíba, 196 - Sala 3
09521-070 São Caetano do Sul - SP
Brazil
Tel. +55 (11) 4229-3379
brasil@sescoi.com