

NTC Accurate Thermistors

NP30 - NJ 28 – NI 24 – NK 20

High precision resistance and an outstanding ability to reproduce the sensibility index B, make these ranges of products the types of thermistors ideal for temperature measurement applications.

Leaded or unleaded, these small size and rapid response time thermistors are able to meet the most accurate requirements.

FEATURES

- High Accuracy
- Fast thermal response
- Commercial, Industrial and Automotive Applications
- AEC-Q200 qualified

OPTIONS

Consult factory for availability of options

- other nominal resistance values
- other tolerances
- controlled dimensions (e.g. reduced head size for NP30)
- alternative lead materials (e.g. steel, nickel)
- customized lead lengths, spacing, forming (kink) etc.
- epoxy coating on leads (NP30)

APPLICATIONS

- Temperature measurement
- Liquid level or flow detection
- Alarms and fire detectors
- HVAC and Refrigeration
- Fans
- Air intake temperature
- Electric pup module
- Water Temperature
- Evaporator probe
- and more

Types	NJ 28	NP 30	NI 24	NK 20
Finish	Coated chip with phenolic resin + varnish + tinned copper wires	Coated chip with epoxy	Coated chip with epoxy AWG30 insulated leads + Silver plated nickel wires	Chip
DIMENSIONS: millimeters (inches)				
Marking	On packaging only			
Operating temperature	-55°C to +150°C			
Tolerance on Rn (25°C)	±1%, ±2%, ±3%			
Maximum dissipation at 25°C	0.16 W			
Thermal dissipation factor*	3 mW/°C		3 mW/°C	2 mW/°C
Thermal time constant	8 s		8 s	6 s
Response time	< 2 s			

NTC Accurate Thermistors

NP30 - NJ 28 – NI 24 – NK 20



TABLE OF VALUES

Types	Rn at 25°C (Ω)	Material Code	B (K)	α at 25°C (%/°C)
N_ _ _ KA 0202	2,000	KA	3625 ± 1%	- 4.1
N_ _ _ MA 0302	3,000	MA	3965 ± 0.5%	- 4.5
N_ _ _ MA 0502	5,000	MA	3965 ± 0.5%	- 4.5
N_ _ _ MA 0103	10,000	MA	3965 ± 0.5%	- 4.5
N_ _ _ NA 0103	10,000	NA	4100 ± 1%	- 4.6
N_ _ _ PA 0203	20,000	PA	4235 ± 1%	- 4.8
N_ _ _ QA 0503	50,000	QA	4250 ± 1%	- 4.8
N_ _ _ RA 0104	100,000	RA	4380 ± 1%	- 4.9

* -- = Add type as outlined above (Example NJ 2 8).

Resistance - Temperature characteristics: pages 30 to 34.

HOW TO ORDER

NJ28



Type
NP30
NJ28
NI24

MA



Material Code
MA
(See table above)

0502



Resistance
5 kΩ
(See table above)

M



Tolerance
F (±1%)
G (±2%)
H (±3%)

--



Packaging
--: Bulk
Ammopack (for NP30 and NJ28)
(See table page 25)
Tape and reel (for NP30 and NJ28)
(See table page 25)

NTC Thermistors Manufacturing Process



NP30 - NJ 28 - NI 24 - NK 20

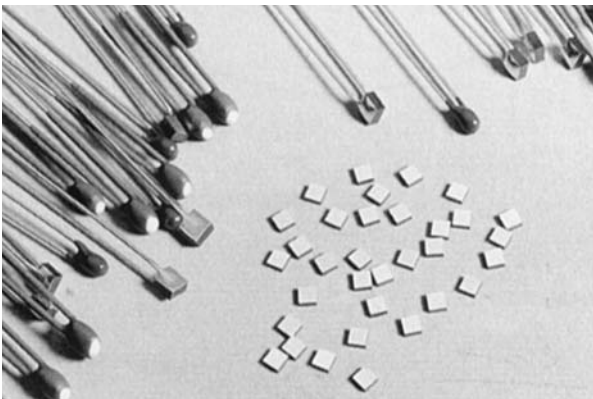
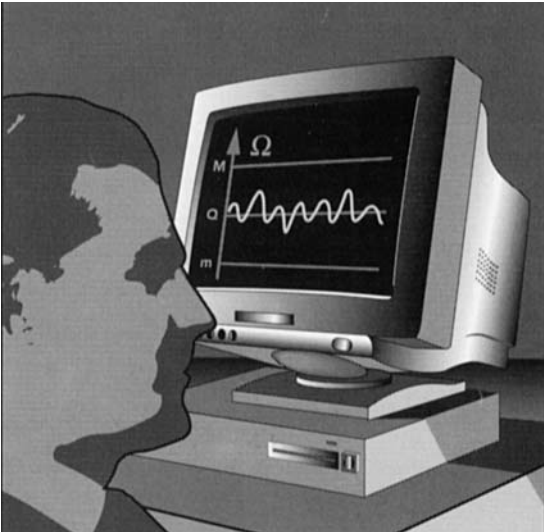
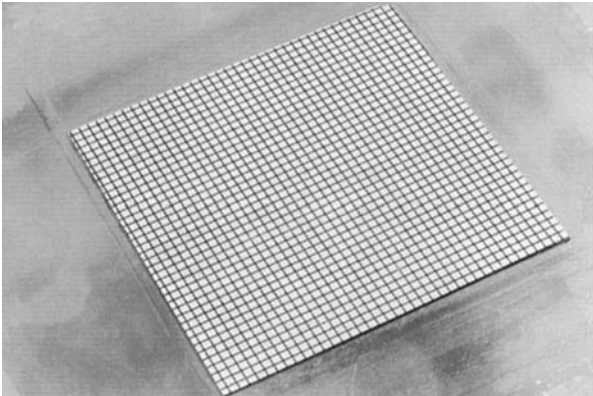
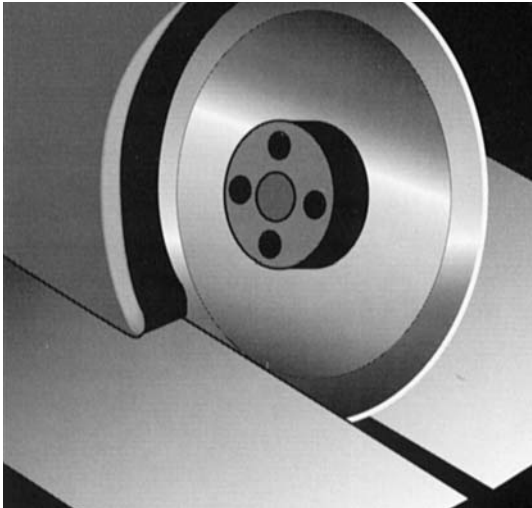
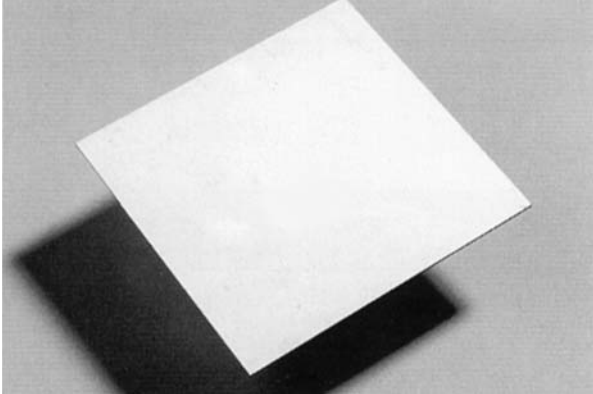
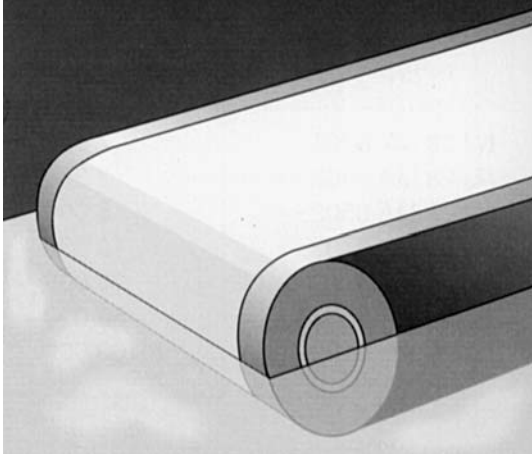

NTC Disc Thermistors

Packaging for Automatic Insertion



PACKAGING AND KINK SUFFIXES

Tables below indicate the suffixes to specify when ordering to get the required kink and packaging. For devices on tape, it is necessary to specify the height (H or Ho) which is the distance between the tape axis (sprocket holes axis) and the seating plane on the printed circuit board. The following types can be ordered on tape either in AMMOPACK (fan folder) or on REEL in accordance with IEC 286-2.

– Straight leads:

H represents the distance between the sprocket holes axis and the bottom plane of component body (base of resin or base of stand off).

– Kinked leads and flat leads:

Ho represents the distance between the sprocket holes axis and the base on the knee (kinked leads) or the bottom of the flat part (flat leads).

• Reel & Ammopack

millimeters (inches)

Types	Suffix	H or Ho	Leads	Quantity/Size	Packaging
ND/NE 03 & NJ28	CA	16 ± 0.5 (0.630 ± 0.020)	Straight	3000	AMMOPACK
	CB	16 ± 0.5 (0.630 ± 0.020)	Straight	3000	REEL
	CC	19.5 ± 0.5 (0.768 ± 0.020)	Straight	3000	AMMOPACK
	CD	19.5 ± 0.5 (0.768 ± 0.020)	Straight	3000	REEL
NP30	CA	16 ± 0.5 (0.630 ± 0.020)	Straight	1500	AMMOPACK
	CB	16 ± 0.5 (0.630 ± 0.020)	Straight	1500	REEL
	CC	19.5 ± 0.5 (0.768 ± 0.020)	Straight	3000	AMMOPACK
	CD	19.5 ± 0.5 (0.768 ± 0.020)	Straight	3000	REEL
ND/NE/NV 06/09	DA	16 ± 0.5 (0.630 ± 0.020)	Straight	1500	AMMOPACK
	DB	16 ± 0.5 (0.630 ± 0.020)	Straight	1500	REEL
	DC	19.5 ± 0.5 (0.768 ± 0.020)	Straight	1500	AMMOPACK
	DD	19.5 ± 0.5 (0.768 ± 0.020)	Straight	1500	REEL
	DL	16 ± 0.5 (0.630 ± 0.020)	Kinked	1500	AMMOPACK
	DM	16 ± 0.5 (0.630 ± 0.020)	Kinked	1500	REEL
	DN	19.5 ± 0.5 (0.768 ± 0.020)	Kinked	1500	AMMOPACK
	DP	19.5 ± 0.5 (0.768 ± 0.020)	Kinked	1500	REEL

NTC

Type
ND03
NE03
NJ28
NP30

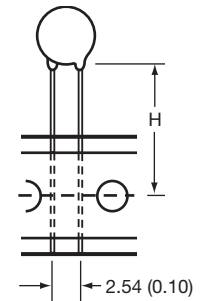

NTC

Types
ND/NE/NV
06/09

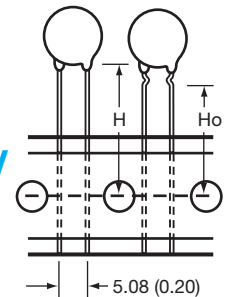

• Bulk

Type	Quantity/box
ND/NE03	3000
ND/NE06	1500
ND/NE09	1500
NV06	100
NV09	100
NI24 NJ28 NK20 NP30	1000



Automatic Insertion

NTC Disc Thermistors



TAPING CHARACTERISTICS

Missing components

A maximum of 3 consecutive components may be missing from the bandolier, surrounded by at least 6 filled positions. The number of missing components may not exceed 0.5% of the total per packing module.

The beginning and the end of tape exhibit 8 or 9 blank positions.

DIMENSIONS: millimeters (inches)

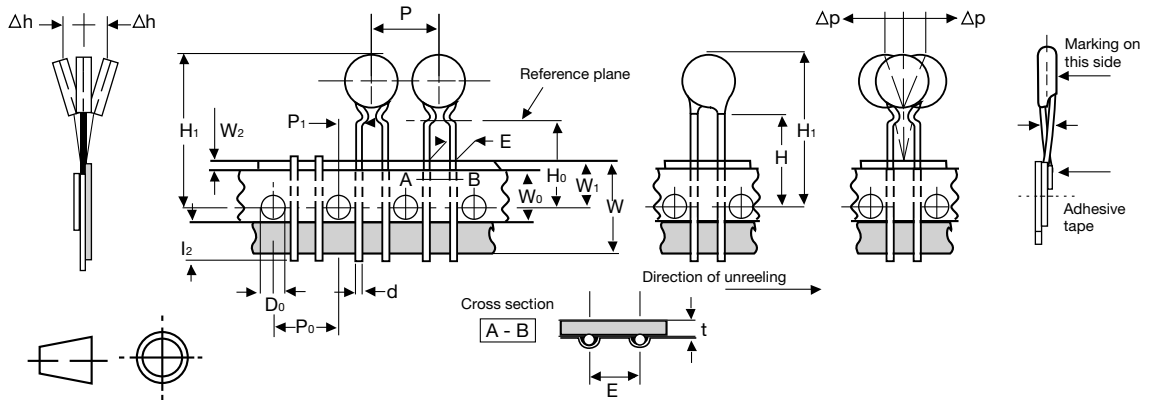
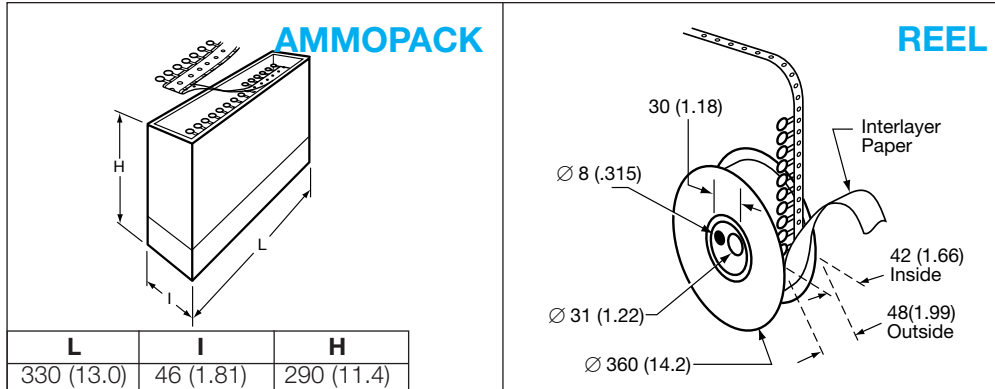

Value	Tolerance	Dimensions Characteristics
18	+1 / -0.5	W Leading tape width
6	±0.3	W ₀ Adhesive tape width
9	+0.75 / -0.5	W ₁ Sprocket hole position
3 max.		W ₂ Distance between the top of the tape and the adhesive
4	±0.2	D ₀ Diameter of sprocket hole
16/19.5	±0.5	H ₀ Distance between the tape axis and the seating plane of the component
		H ₁ Distance between the tape axis and the top of component body

Value	Tolerance	Dimensions Characteristics
12.7	±0.2	P ₀ Sprocket holes pitch
254	±1	- Distance between 21 consecutive holes 20 pitches
0.7	±0.2	t Total thickness of tape
2.54 5.08	+0.6 -0.1	E Lead spacing
5.08 3.85	± 0.7	P ₁ Distance between the sprocket hole axis and the lead axis
12.7	±1.0	P Spacing of components
0.5 0.6	±5%	d Lead diameter
0	±1.3	³ P Verticality of components
0	±2	³ h Alignment of components



Tables of Resistance vs Temperature

T (°C)	Material B(K)		
	T 4630		
	R(T) / R25	TF (%)	α (%/°C)
-55	137.06	27.2	-7.33
-50	94.94	23.5	-7.15
-45	66.35	20.2	-6.98
-40	46.78	17.3	-6.82
-35	33.25	14.7	-6.66
-30	23.84	12.4	-6.50
-25	17.23	10.3	-6.35
-20	12.54	8.5	-6.20
-15	9.206	6.9	-6.05
-10	6.807	5.6	-5.91
-5	5.070	4.3	-5.77
0	3.803	3.3	-5.63
5	2.873	2.4	-5.50
10	2.185	1.6	-5.36
15	1.673	1.0	-5.23
20	1.289	0.4	-5.11
25	1.0000	0.0	-4.99
30	0.7805	0.4	-4.86
35	0.6129	0.9	-4.75
40	0.4841	1.4	-4.63
45	0.3847	2.0	-4.52
50	0.3074	2.6	-4.41
55	0.2470	3.3	-4.30
60	0.1996	4.0	-4.19
65	0.1621	4.7	-4.09
70	0.1323	5.4	-3.99
75	0.1086	6.2	-3.89
80	0.08951	7.0	-3.80
85	0.07416	7.8	-3.71
90	0.06172	8.6	-3.62
95	0.05160	9.5	-3.53
100	0.04333	10.3	-3.44
105	0.03655	11.2	-3.36
110	0.03095	12.0	-3.28
115	0.02632	12.9	-3.20
120	0.02246	13.7	-3.12
125	0.01925	14.6	-3.05
130	0.01656	15.5	-2.97
135	0.01429	16.4	-2.90
140	0.01238	17.3	-2.83
145	0.01076	18.1	-2.77
150	0.009383	19.0	-2.70

T (°C)	Material B(K)		
	U 4840		
	R(T) / R25	TF (%)	α (%/°C)
-55	173.74	28.5	-7.69
-50	118.20	24.6	-7.50
-45	81.18	21.2	-7.32
-40	56.26	18.1	-7.15
-35	39.34	15.4	-6.98
-30	27.75	12.9	-6.82
-25	19.74	10.8	-6.66
-20	14.15	8.9	-6.50
-15	10.23	7.3	-6.34
-10	7.457	5.8	-6.19
-5	5.476	4.5	-6.04
0	4.051	3.4	-5.90
5	3.020	2.5	-5.76
10	2.267	1.7	-5.62
15	1.714	1.0	-5.48
20	1.305	0.5	-5.35
25	1.0000	0.0	-5.22
30	0.7715	0.4	-5.09
35	0.5991	0.9	-4.97
40	0.4681	1.5	-4.84
45	0.3680	2.1	-4.72
50	0.2911	2.8	-4.61
55	0.2316	3.4	-4.49
60	0.1853	4.2	-4.38
65	0.1491	4.9	-4.28
70	0.1206	5.7	-4.17
75	0.09812	6.5	-4.07
80	0.08022	7.3	-3.97
85	0.06591	8.2	-3.87
90	0.05442	9.0	-3.77
95	0.04515	9.9	-3.68
100	0.03763	10.8	-3.59
105	0.03150	11.7	-3.50
110	0.02649	12.6	-3.42
115	0.02237	13.5	-3.33
120	0.01897	14.4	-3.25
125	0.01615	15.3	-3.17
130	0.01380	16.2	-3.10
135	0.01184	17.1	-3.02
140	0.01020	18.0	-2.95
145	0.008814	19.0	-2.88
150	0.007643	19.9	-2.81

Mouser Electronics

Authorized Distributor

Click to View Pricing, Inventory, Delivery & Lifecycle Information:

[AVX:](#)

[NJ28KA0202F--](#) [NJ28MA0103H--](#) [NJ28MA0302F--](#) [NJ28MA0302H--](#) [NJ28MA0502F--](#) [NJ28PA0203F--](#)
[NJ28QA0503F--](#) [NJ28RA0104F--](#) [NJ28MA0103F--](#) [NJ28MA0302G--](#) [NJ28KA0202H--](#) [NJ28RA0104H--](#)
[NJ28MA0502G](#)