

MB8464A-80/-80L/-80LL/-10/-10L/-10LL/-15/-15L/-15LL

CMOS 64K BIT LOW POWER SRAM

8K Words x 8 Bits CMOS Static RAM with Low Power and Data Retention

The Fujitsu MB8464A is a 8,192 words x 8 bits static random access memory fabricated with a CMOS silicon gate process. The memory uses asynchronous circuitry and may be maintained in any state for an indefinite period of time. All pins are TTL compatible and a single +5 V power supply is required.

The MB8464A has low power dissipation, low cost, and high performance, and it is ideally suited for use in microprocessor systems and other applications where fast access time and ease of use are required.

- Organization: 8,192 words x 8 bits
- Access time: 80 ns max. (MB8464A-80/-80L/-80LL)
100 ns max. (MB8464A-10/-10L/-10LL)
150 ns max. (MB8464A-15/-15L/-15LL)
- Static operation: no clock required
- TTL compatible inputs and outputs
- Three-state outputs
- Common data inputs and outputs
- Single +5 V power supply $\pm 10\%$ tolerance
- Low power standby: 11 mW max. (MB8464A-80/-10/-15)
0.55 mW max. (MB8464A-80L/-10L/-15L)
0.55 mW max. (MB8464A-80LL/-10LL/-15LL)
- Data retention current: 1 mA max. (MB8464A-80/-10/-15)
25 μ A max. (MB8464A-80L/-10L/-15L)
2 μ A max. at 0°C to 40°C
(MB8464A-80LL/-10LL/-15LL)
- Data retention: 2.0 V min.
- Standard 28-pin Plastic Packages:
 - DIP (600 mil) MB8464A-xx(L/L)P
 - Skinny DIP (300 mil) MB8464A-xx(L/L)PSK
 - SOP (450 mil) MB8464A-xx(L/L)PF
- Standard 32-pad Ceramic Package:
 - LCC (metal seal) MB8464A-xx(L/L)CV

Absolute Maximum Ratings (See Note)

Rating	Symbol	Value	Unit
Supply Voltage	V_{CC}	-0.5 to +7.0	V
Input Voltage	V_{IN}	-0.5* to $V_{CC} + 0.5$	V
Output Voltage	V_{OUT}	-0.5 to $V_{CC} + 0.5$	V
Temperature Under Bias	T_{BIAS}	-10 to +85	°C
Storage Temperature Range	Ceramic	-65 to +150	°C
	Plastic	-45 to +125	

* -2.0 V for pulse width less than 20 ns.

Note: Permanent device damage may occur if absolute maximum ratings are exceeded. Functional operation should be restricted to the conditions as detailed in the operation sections of this data sheet. Exposure to absolute maximum rating conditions for extended periods may affect device reliability.

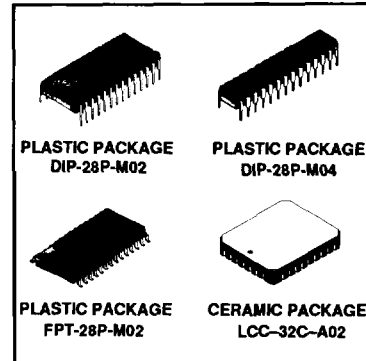

3

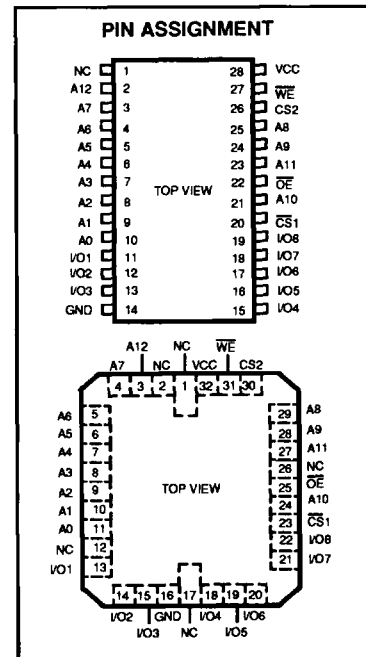

This device contains circuitry to protect the inputs against damage due to high static voltages or electric fields. However, it is advised that normal precautions be taken to avoid application of any voltage higher than maximum rated voltages to this high impedance circuit.

MB8464A-80/80L/80LL
 MB8464A-10/10L/10LL
 MB8464A-15/15L/15LL

3

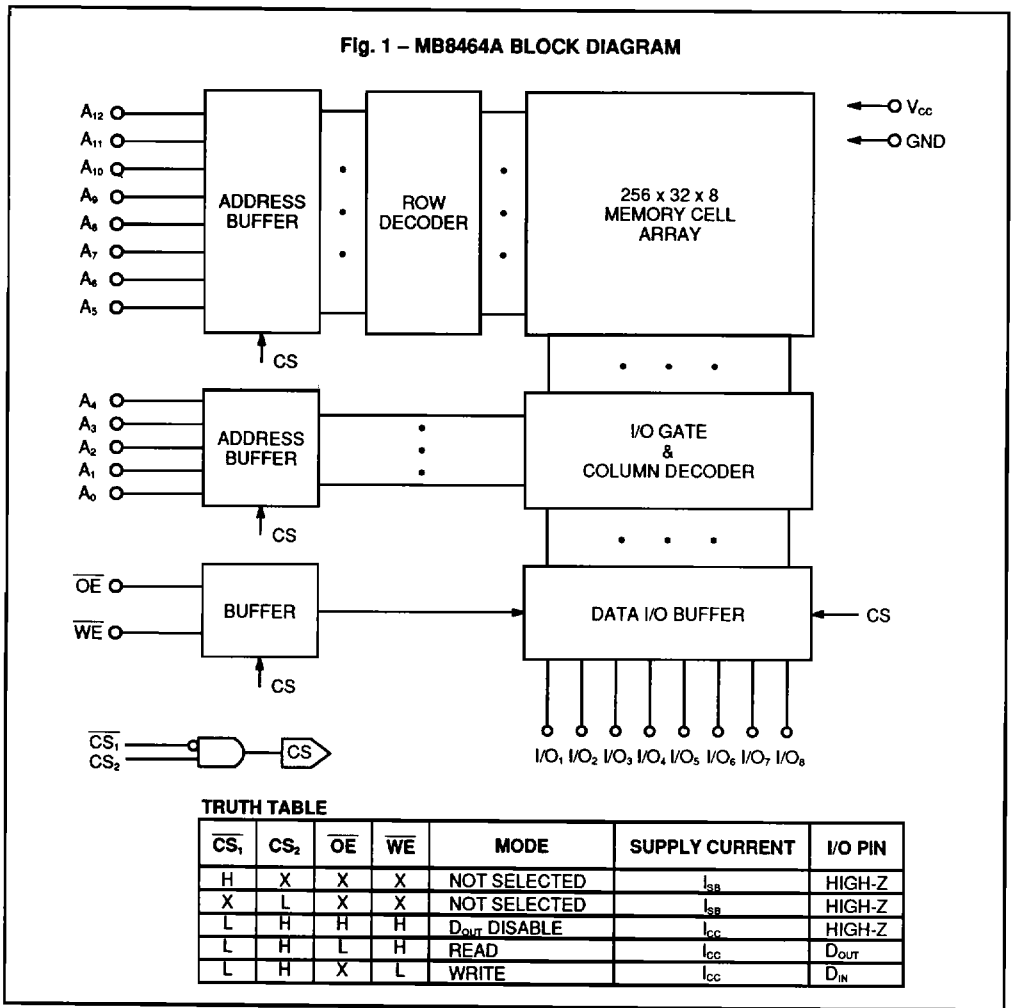

CAPACITANCE ($T_A = 25^\circ C, f = 1MHz$)

Parameter	Symbol	Min	Typ	Max	Unit
I/O Capacitance ($V_{IO} = 0V$)	C_{IO}			8	pF
Input Capacitance ($V_{IN} = 0V$)	C_{IN}			6	pF

RECOMMENDED OPERATING CONDITIONS

(Referenced to GND)

Parameter	Symbol	Min	Typ	Max	Unit
Supply Voltage	V_{CC}	4.5	5.0	5.5	V
Ambient Temperature	T_A	0		70	°C

DC CHARACTERISTICS

(Recommended operating conditions unless otherwise noted.)

Parameter	Symbol	MB8464A-80/10/15		MB8464A-80L/80LL 10L/10LL/15L/15LL		Unit	Test Condition
		Min	Max	Min	Max		
Standby Supply Current	I_{SB1}		2		0.1	mA	$CS_2 \leq 0.2V, \overline{CS}_1 \geq V_{CC} - 0.2V$ ($CS_2 \leq 0.2V$ or $CS_2 \geq V_{CC} - 0.2V$)
	I_{SB2}		3		3	mA	$\overline{CS}_1 = V_{IH}$ or $CS_2 = V_L$
Active Supply Current	I_{CC1}		50		50	mA	$\overline{CS}_1 = V_{IL}, CS_2 = V_{IH}$ $V_{IH} = V_{IH}$ or $V_{IL}, I_{OUT} = 0mA$
Operating Supply Current	I_{CC2}		60		60	mA	Cycle=Min., Duty=100% $I_{OUT} = 0mA$
Input Leakage Current	I_U	-1	1	-1	-1	μA	$V_{IH} = 0V$ to V_{CC}
Output Leakage Current	I_{L0}	-2	2	-2	2	μA	$V_{IO} = 0V$ to V_{CC} $\overline{CS}_1 = V_{IH}$ or $CS_2 = V_{IL}$ or $OE = V_{IH}$ or $WE = V_L$
Input Low Voltage	V_{IL}	-2.0*	0.8	-2.0*	0.8	V	
Input High Voltage	V_{IH}	2.2	$V_{CC} + 0.3$	2.2	$V_{CC} + 0.3$	V	
Output High Voltage	V_{OH}	2.4		2.4		V	$I_{OH} = -1.0mA$
Output Low Voltage	V_{OL}		0.4		0.4	V	$I_{OL} = 2.1mA$

* -2.0V Min for pulse width less than 20ns. (V_{IL} Min. = -0.3V at DC level)

3

Fig. 2 – AC TEST CONDITIONS

- Input Pulse Levels: 0.6V to 2.4V
- Input Pulse Rise and Fall Times: 5ns (Transient Time between 0.8V and 2.2V)
- Timing Reference Levels: Input : $V_{IL} = 0.8V, V_{IH} = 2.2V$
Output : $V_{OL} = 0.8V, V_{OH} = 2.0V$
- Output Load:

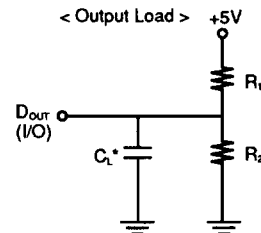

	R_1	R_2	C_1	Parameters Measured
Load I	1.8k Ω	990 Ω	100pF	except $t_{CLZ}, t_{OLZ}, t_{CHZ}, t_{OHZ}, t_{WLZ}$ and t_{WHZ}
Load II	1.8k Ω	990 Ω	5pF	$t_{CLZ}, t_{OLZ}, t_{CHZ}, t_{OHZ}, t_{WLZ}$, and t_{WHZ}

* Including jig and stray capacitance

AC CHARACTERISTICS

(Recommended operating conditions unless otherwise noted)

READ CYCLE

Parameter	Symbol	MB8464A-80/80L/80LL		MB8464A-10/10L/10LL		MB8464A-15/15L/15LL		Unit
		Min	Max	Min	Max	Min	Max	
Read Cycle Time	t_{RC}	80		100		150		ns
Address Access Time	t_{AA}		80		100		150	ns
\overline{CS}_1 Access Time	t_{AC1}		80		100		150	ns
CS_2 Access Time	t_{AC2}		80		100		150	ns
Output Enable to Output Valid	t_{OE}		35		45		55	ns
Output Hold from Address Change	t_{OH}	10		10		10		ns
Chip Select to Output Low-Z*1	t_{CLZ}^{*1}	10		10		10		ns
Output Enable to Output Low-Z*1	t_{OLZ}^{*1}	5		5		5		ns
Chip Select to Output High-Z*1	t_{CHZ}^{*1}		35		35		40	ns
Output Enable to Output High-Z*1	t_{OHZ}^{*1}		30		35		40	ns

READ CYCLE TIMING DIAGRAM *2

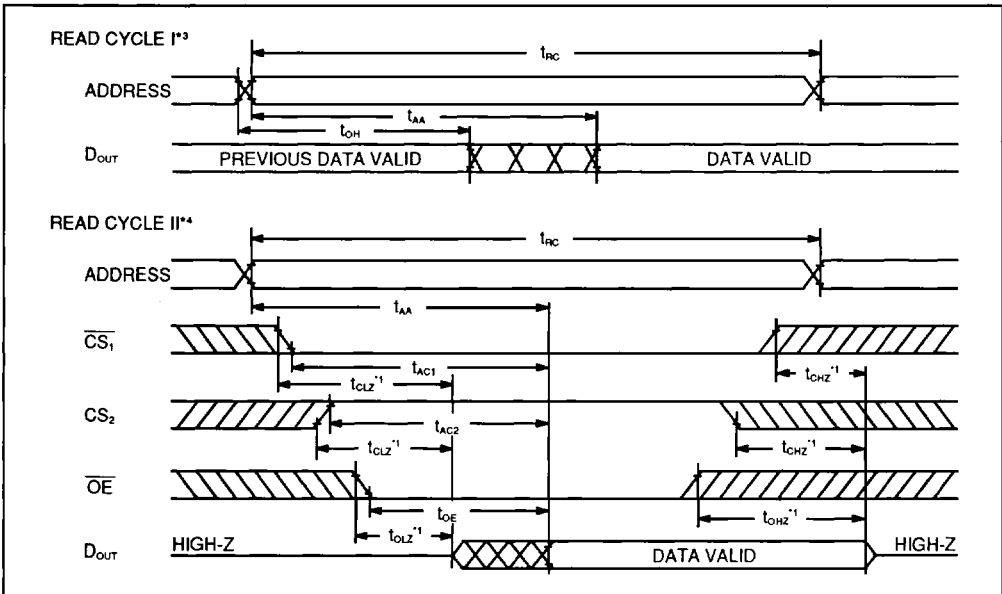

- Note:**
- *1 Transition is measured at the point of $\pm 500mV$ from steady state voltage.
 - *2 WE is high for Read Cycle.
 - *3 Device is continuously selected, $\overline{CS}_1 = \overline{OE} = V_{IL}$, $CS_2 = V_{IH}$.
 - *4 Address valid prior to or coincident with \overline{CS}_1 transition low, CS_2 transition high.

WRITE CYCLE

Parameter	Symbol	MB8464A-80/80L/80LL		MB8464A-10/10L/10LL		MB8464A-15/15L/15LL		Unit
		Min	Max	Min	Max	Min	Max	
Write Cycle Time	t_{WC}	80		100		150		ns
Address Valid to End of Write	t_{AW}	60		80		100		ns
Chip Select to End of Write	t_{CW}	60		80		100		ns
Data Valid to End of Write	t_{DW}	30		35		40		ns
Data Hold Time	t_{DH}	5		5		5		ns
Write Pulse Width	t_{WP}	60		70		90		ns
Address Setup Time	t_{AS}	0		0		0		ns
Write Recovery Time	t_{WR}	5		5		5		ns
Write Enable to Output Low-Z*1	t_{WLZ}	5		5		5		ns
Write Enable to Output High-Z*1	t_{WHZ}		30		35		40	ns

3

WRITE CYCLE TIMING DIAGRAM *2

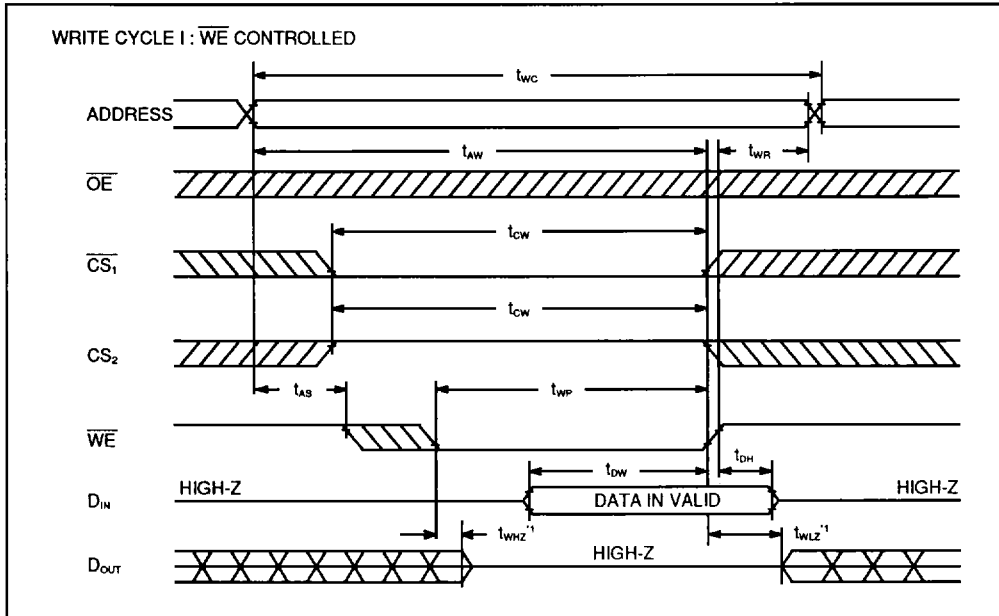

Note: *1 Transition is measured at the point of $\pm 500\text{mV}$ from steady state voltage.
 *2 If \overline{OE} , \overline{CS}_1 and \overline{CS}_2 are in the READ Mode during this period, I/O pins are in the output state so that the input signals of opposite phase to the outputs must not be applied.

MB8464A-80/80L/80LL
 MB8464A-10/10L/10LL
 MB8464A-15/15L/15LL

3

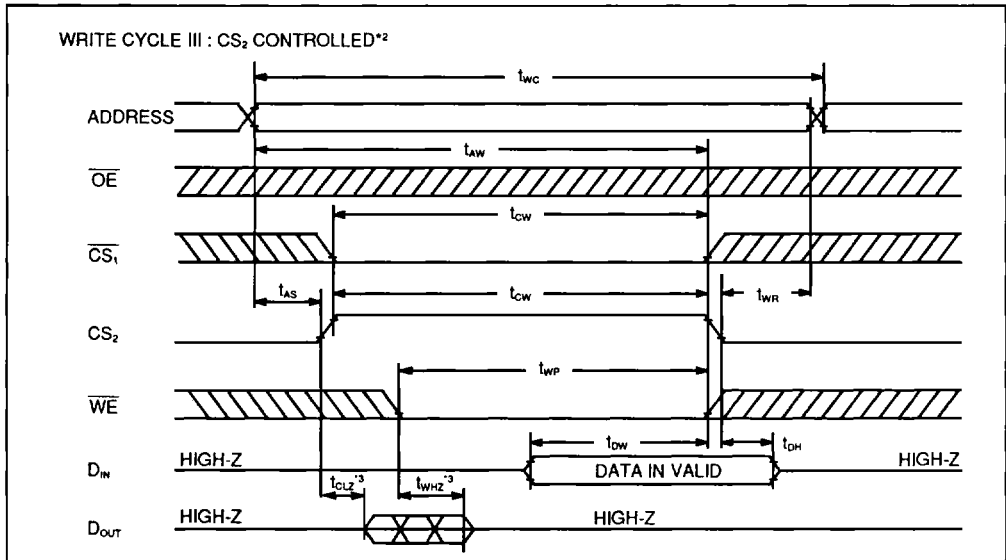
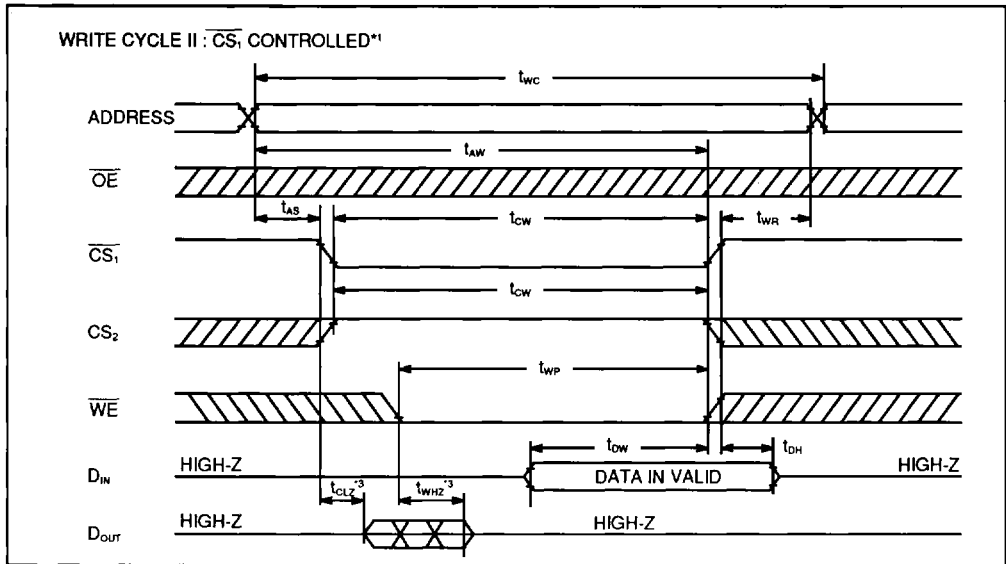

- Note:** *1 If \overline{OE} , CS_2 and \overline{WE} are in the READ Mode during this period, I/O pins are in the output state so that the input signals of opposite phase to the outputs must not be applied.
- *2 If \overline{OE} , CS_1 and \overline{WE} are in the READ Mode during this period, I/O pins are in the output state so that the input signals of opposite phase to the outputs must not be applied.
- *3 Transition is measured at the point of $\pm 500mV$ from steady state voltage.

DATA RETENTION CHARACTERISTICS

(Recommended operating conditions unless otherwise noted)

Parameter	Symbol	Min	Typ	Max	Unit
Data Retention Supply Voltage	V_{DR}	2.0		5.5	V
Data Retention Supply Current*2	Standard			1.0	mA
	L-Version		1.0	25	μ A
	LL-Version*3		1.0	2.0	μ A
Data Retention Setup Time	t_{DRS}	0			ns
Operation Recovery Time	t_R	t_{RC}			ns

Note: *2 CS_2 controlled: $V_{DR}=3.0V$, $CS_2 \leq 0.2V$
 CS_1 controlled: $V_{DR}=3.0V$, $CS_1 \geq V_{DR} - 0.2V$ ($CS_2 \leq 0.2V$ or $CS_2 \geq V_{DR} - 0.2V$)
 *3 $V_{DR}=3.0V$, $T_A=0^\circ C$ to $40^\circ C$

3

DATA RETENTION TIMING

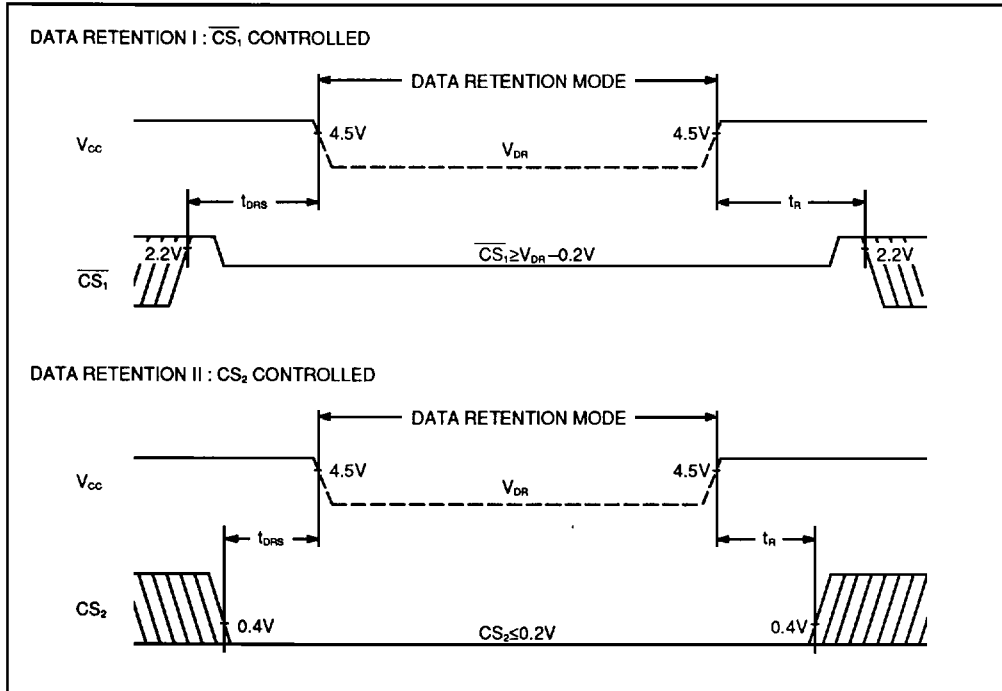

TYPICAL CHARACTERISTICS CURVES

Fig. 3 – NORMALIZED POWER SUPPLY CURRENT vs. SUPPLY VOLTAGE

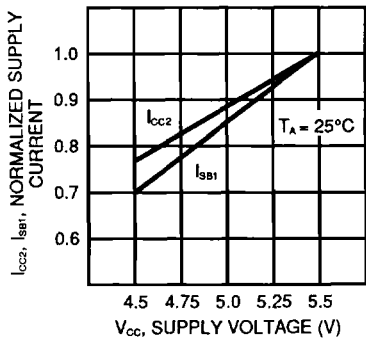

Fig. 4 – NORMALIZED POWER SUPPLY CURRENT vs. AMBIENT TEMPERATURE

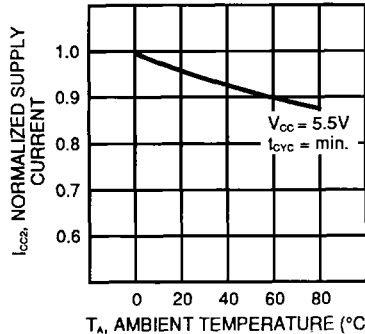

Fig. 5 – NORMALIZED POWER SUPPLY CURRENT vs. CYCLE TIME

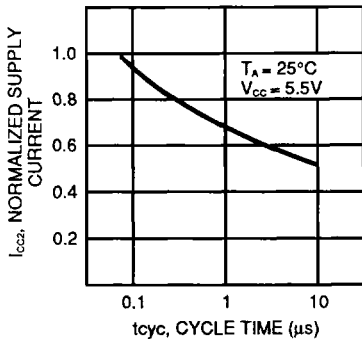

Fig. 6 – NORMALIZED POWER SUPPLY CURRENT vs. AMBIENT TEMPERATURE

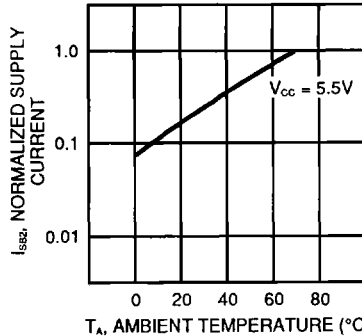

Fig. 7 – NORMALIZED ACCESS TIME vs. SUPPLY VOLTAGE

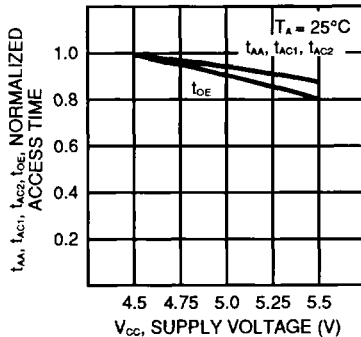
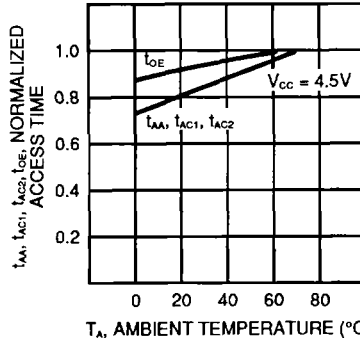

Fig. 8 – NORMALIZED ACCESS TIME vs. AMBIENT TEMPERATURE



MB8464A-80/80L/80LL
 MB8464A-10/10L/10LL
 MB8464A-15/15L/15LL

PACKAGE DIMENSIONS

(Suffix: P)

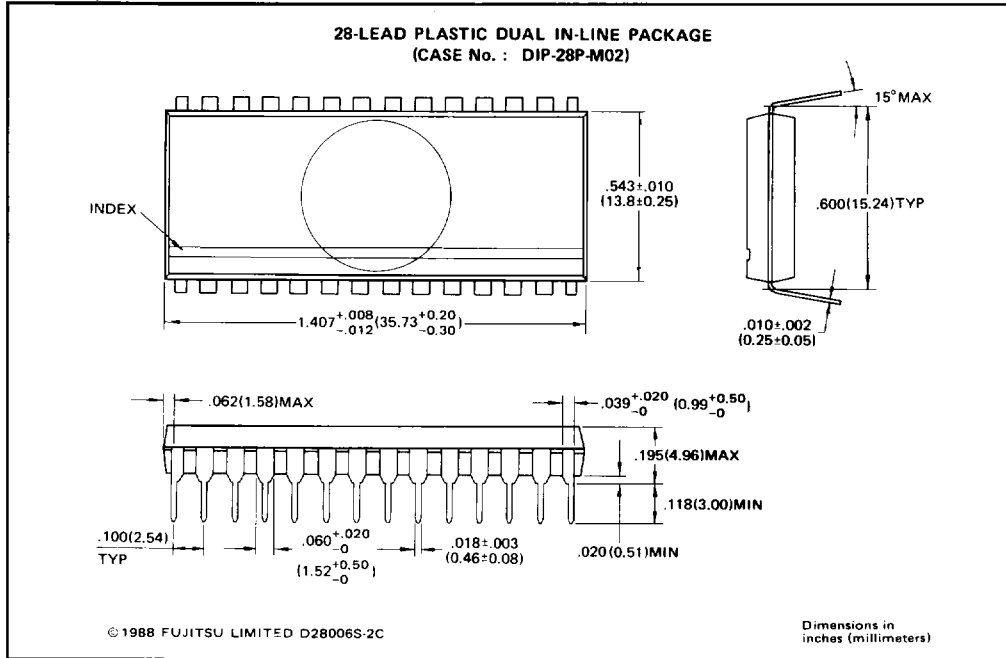

3

MB8464A-80/80L/80LL
 MB8464A-10/10L/10LL
 MB8464A-15/15L/15LL

PACKAGE DIMENSIONS

(Suffix: P-SK)

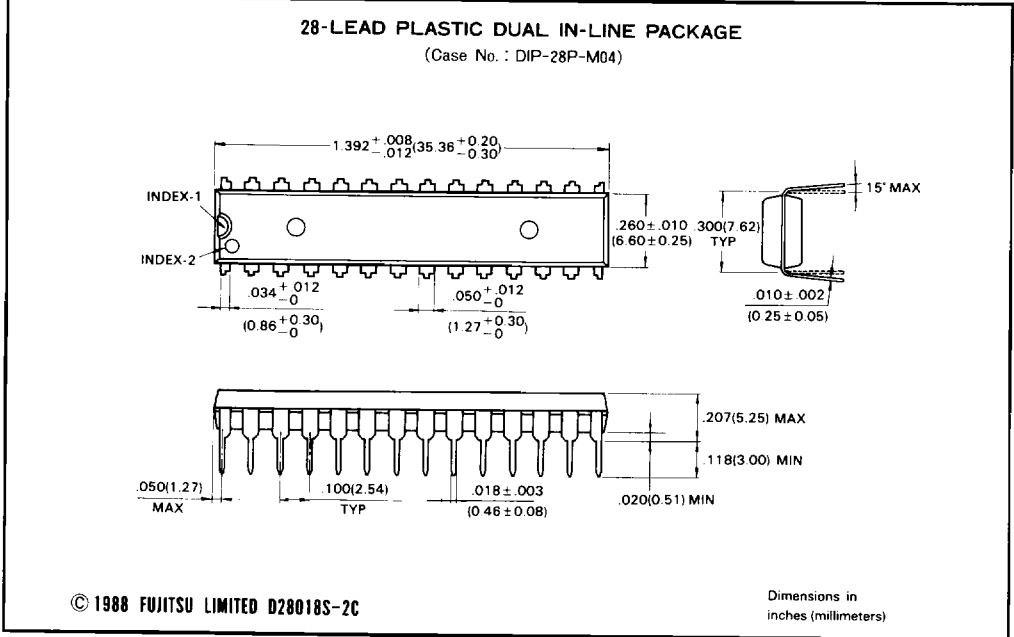

3

PACKAGE DIMENSIONS (Cont'd)

(Suffix: PF)

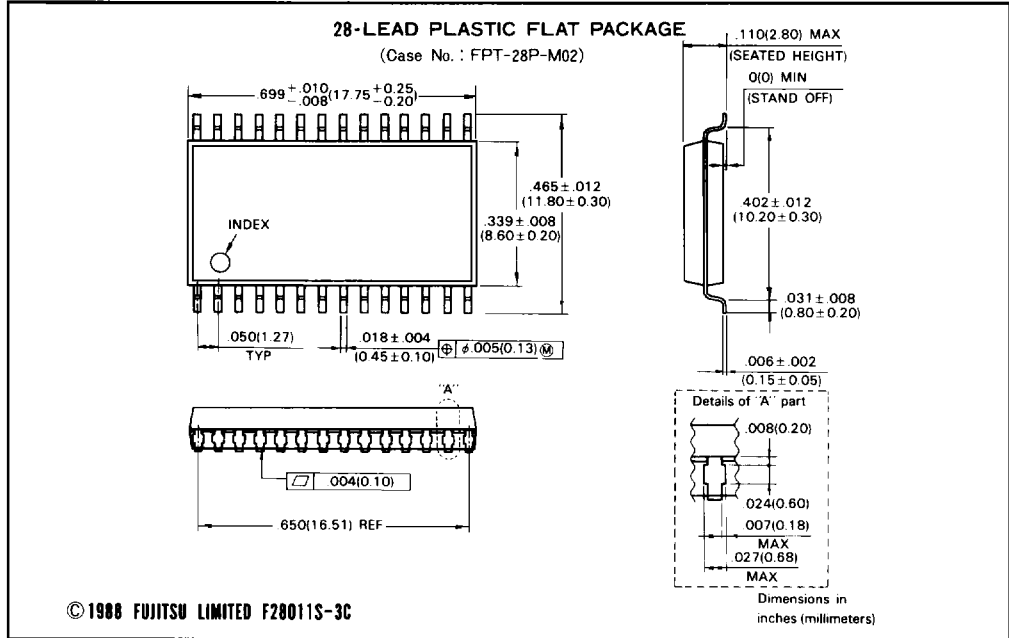

MB8464A-80/80L/80LL
 MB8464A-10/10L/10LL
 MB8464A-15/15L/15LL

PACKAGE DIMENSIONS (Cont'd)

(Suffix: CV)

32-PAD CERAMIC (METAL SEAL) LEADLESS CHIP CARRIER
 (CASE No.: LCC-32C-A02)

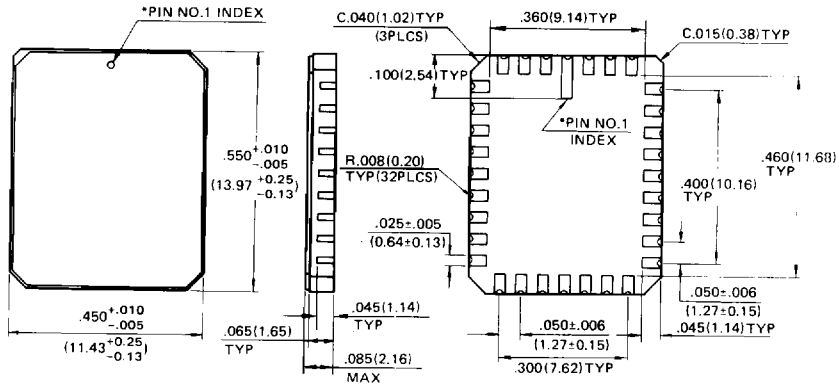

* Shape of PIN NO. 1 INDEX: Subject to change without notice.

Dimensions in inches
(millimeters)

©1988 FUJITSU LIMITED C32011S-3C

3