



Wireless Components

RF/IF Double PLL Frequency Synthesizer

PMB 2347 Version 1.1

Specification August 1999

preliminary

Revision History: Current Version: 08.99		
Previous Version:Data Sheet		
Page (in previous Version)	Page (in current Version)	Subjects (major changes since last revision)

ABM®, AOP®, ARCOFI®, ARCOFI®-BA, ARCOFI®-SP, DigiTape®, EPIC®-1, EPIC®-S, ELIC®, FALC®54, FALC®56, FALC®-E1, FALC®-LH, IDEC®, IOM®, IOM®-1, IOM®-2, IPAT®-2, ISAC®-P, ISAC®-S, ISAC®-S TE, ISAC®-P TE, ITAC®, IWE®, MUSAC®-A, OCTAT®-P, QUAT®-S, SICAT®, SICOFI®, SICOFI®-2, SICOFI®-4, SICOFI®-4µC, SLICOFI® are registered trademarks of Infineon Technologies AG.

ACE™, ASM™, ASP™, POTSWIRE™, QuadFALC™, SCOUT™ are trademarks of Infineon Technologies AG.

Edition 03.99

**Published by Infineon Technologies AG i. Gr.,
SC,
Balanstraße 73,
81541 München**

© Infineon Technologies AG i. Gr. 25.10.99.
All Rights Reserved.

Attention please!

As far as patents or other rights of third parties are concerned, liability is only assumed for components, not for applications, processes and circuits implemented within components or assemblies.

The information describes the type of component and shall not be considered as assured characteristics.

Terms of delivery and rights to change design reserved.

Due to technical requirements components may contain dangerous substances. For information on the types in question please contact your nearest Infineon Technologies Office.

Infineon Technologies AG is an approved CECC manufacturer.

Packing

Please use the recycling operators known to you. We can also help you – get in touch with your nearest sales office. By agreement we will take packing material back, if it is sorted. You must bear the costs of transport.

For packing material that is returned to us unsorted or which we are not obliged to accept, we shall have to invoice you for any costs incurred.

Components used in life-support devices or systems must be expressly authorized for such purpose!

Critical components¹ of the Infineon Technologies AG, may only be used in life-support devices or systems² with the express written approval of the Infineon Technologies AG.

1 A critical component is a component used in a life-support device or system whose failure can reasonably be expected to cause the failure of that life-support device or system, or to affect its safety or effectiveness of that device or system.

2 Life support devices or systems are intended (a) to be implanted in the human body, or (b) to support and/or maintain and sustain human life. If they fail, it is reasonable to assume that the health of the user may be endangered.

Productinfo

General Description

The PMB 2347 is a RF/IF double PLL frequency synthesizer implemented in Infineon' high speed BiCMOS technology B6HFC. The device contains two PLLs with integrated prescalers especially designed for use in battery powered radio equipment and mobile telephones. Primary applications are single- and dual-band digital cellular systems e.g. GSM, PCN (DCS 1800) and PCS systems.

Package

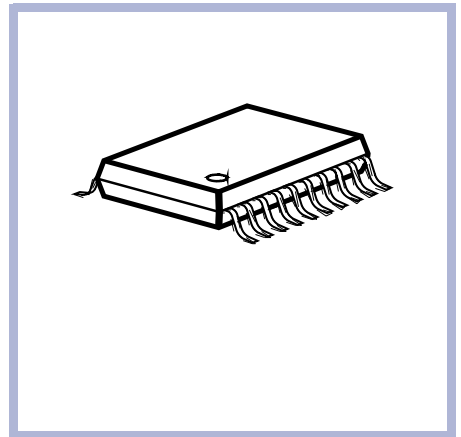

Features

- Operation range 2.7 to 5.0 V
- Low operating current consumption
- Programmable power down modes
- High input sensitivity and high input frequencies: PLL1 (RF): 2.8 GHz
PLL2 (IF): 500 MHz
- Programmable dual modulus prescaler divide ratio:
PLL1: 1:64/65 or 1:32/33
PLL2: 16/17 or 1:8/9
Dividing ratios:
A counters: PLL1: 0 to 63
PLL2: 0 to 15
N counters: PLL1: 3 to 16,383
PLL2: 3 to 16,383
R counters 3 to 16,383 for PLL1 and PLL2
- Fast phase detectors and charge pump outputs without dead zone
- High phase noise performance
- Switchable polarity and programmable phase detector currents
- External reference current setting for PD outputs
- Fast serial 3-wire bus interface with low threshold voltage Schmitt-Trigger inputs for interfacing with low voltage baseband circuits
- Two data registers in PLL2 for fast IF band switching
- A programmable multi-functional output port for lock detect (quasi-digital lock detect) and test mode

Ordering Information

Type	Ordering Code	Package
PMB 2347		P-TSSOP-20

1 Table of Contents

1	Table of Contents	1-1
2	Product Description	2-1
2.1	Overview	2-2
2.2	Features	2-2
2.3	Package Outlines	2-3
3	Functional Description	3-1
3.1	Pin Configuration	3-2
3.2	Pin Definition and Function	3-2
3.3	Functional Block Diagram	3-6
3.4	Circuit Description	3-7
4	Applications	4-1
4.1	Hint	4-2
5	Reference	5-1
5.1	Electrical Data	5-2
5.1.1	Absolute Maximum Ratings	5-2
5.1.2	Operating Range	5-3
5.1.3	Typical Supply Current ICC	5-3
5.1.4	AC/DC Characteristics	5-4
5.2	Serial Control Data Format Timing	5-7
5.3	Serial Control Data Formats	5-8
5.4	Input Sensitives	5-13
5.5	Charge Pump Currents	5-15
5.6	Threshold Voltages of Schmitt-Trigger Input	5-16

2 Product Description

Contents of this Chapter

2.1	Overview	2-2
2.2	Features	2-2
2.3	Package Outlines	2-3

2.1 Overview

The PMB 2347 is a RF/IF double PLL frequency synthesizer implemented in Infineon' high speed BiCMOS technology B6HFC. The device contains two PLLs with integrated prescalers especially designed for use in battery powered radio equipment and mobile telephones. Primary applications are single- and dual-band digital cellular systems e.g. GSM, PCN (DCS 1800) and PCS systems.

2.2 Features

- Operation range 2.7 to 5.0 V
- Low operating current consumption
- Programmable power down modes
- High input sensitivity and high input frequencies:
PLL1 (RF): 2.8 GHz PLL2 (IF): 500 MHz
- Programmable dual modulus prescaler divide ratio:
PLL1: 1:64/65 or 1:32/33 PLL2: 16/17 or 1:8/9
Dividing ratios:
A counters: PLL1: 0 to 63 PLL2: 0 to 15
N counters: PLL1: 3 to 16,383 PLL2: 3 to 16,383
R counters 3 to 16,383 for PLL1 and PLL2
- Fast phase detectors and charge pump outputs without dead zone
- High phase noise performance
- Switchable polarity and programmable phase detector currents
- External reference current setting for PD outputs
- Fast serial 3-wire bus interface with low threshold voltage Schmitt-Trigger inputs for interfacing with low voltage baseband circuits
- Two data registers in PLL2 for fast IF band switching
- A programmable multi-functional output port for lock detect (quasidigital lock detect) and test mode

2.3 Package Outlines

P-TSSOP-20

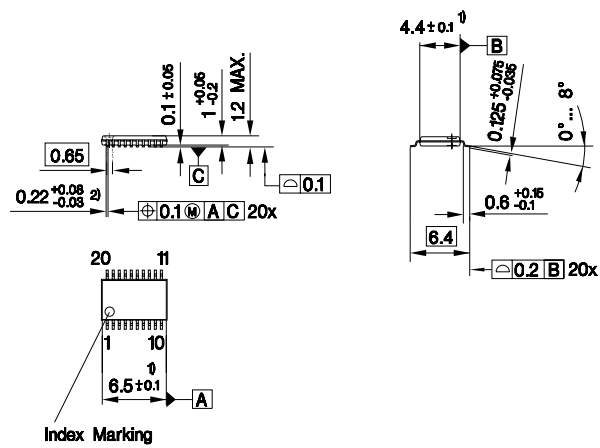

Index Marking

- 1) Does not include plastic or metal protrusion of 0.15 max. per side
- 2) Does not include dambar protrusion of 0.08 max. per side

3 Functional Description

Contents of this Chapter

3.1	Pin Configuration	3-2
3.2	Pin Definition and Function	3-2
3.3	Functional Block Diagram	3-6
3.4	Circuit Description	3-7
1	General Description	3-7
2	Programming	3-7
3	Standby Condition (power down)	3-8
4	Divide ratio programming	3-9
5	Prescaler Divide Ratio	3-9
6	Fast wake-up programming	3-9
7	Phase Detector Outputs	3-10

3.1 Pin Configuration

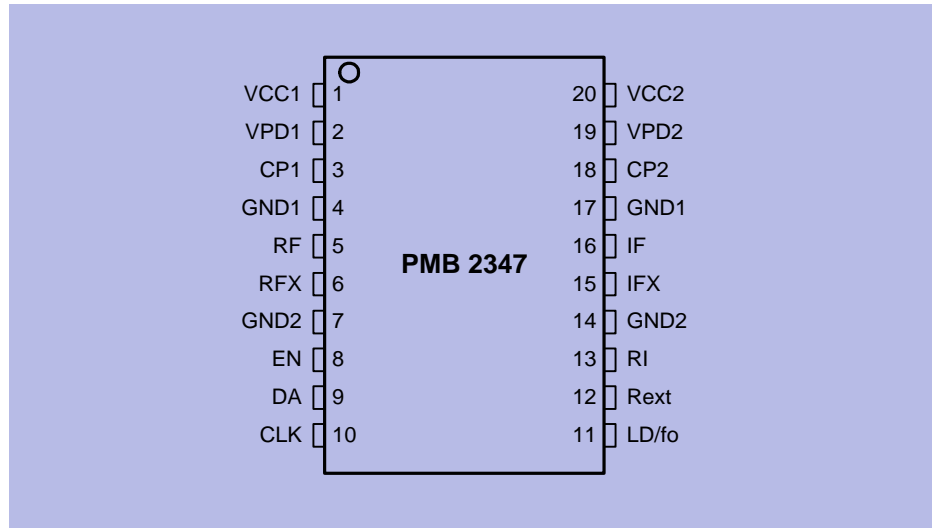

Pin_config.wmf

Figure 3-1 Pin Configuration

3.2 Pin Definition and Function

Table 3-1 Pin Definition and Function			
Pin No.	Symbol	Equivalent I/O-Schematic	Function
1	VCC1		Positive supply voltage for CMOS circuitry
2	VPD1		Positive supply voltage for charge pump of PLL1
3	CP1		PLL1 charge pump output Phase detector tristate charge pump output

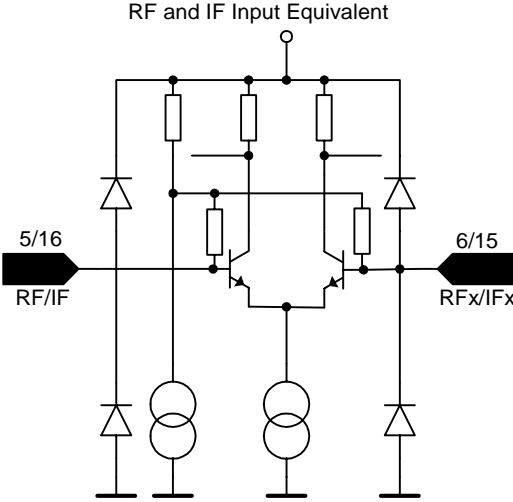
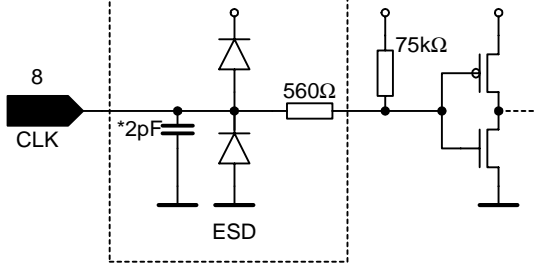
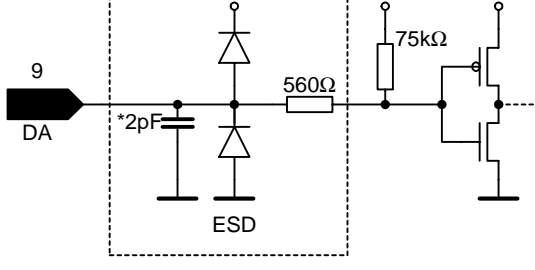
4	GND1		Ground for CMOS circuitry
5	RF1	<p style="text-align: center;">RF and IF Input Equivalent</p> 	<p>RF frequency input 1 RF input with highly sensitive preamplifier for PLL1. AC coupling must be set up.</p> <p>RF frequency input (inverted) RF input with highly sensitive preamplifier for PLL1. AC coupling must be set up</p>
6	RFX		
7	GND1		Ground for bipolar circuitry
8	EN	<p style="text-align: center;">Serial Control Input Equivalent</p> 	<p>3-Wire bus input: Enable Enable input of the serial control interface with Schmitt-Trigger input stage. When EN=H the input signals CLK and DA are disabled. When EN=L the serial control interface is enabled. The received data are transferred to the registers with the positive edge of the EN-signal.</p>
9	DA	<p style="text-align: center;">Serial Control Input Equivalent</p> 	<p>3-Wire bus input: Data Data input of the serial control interface with Schmitt-Trigger input stage. The serial data are read into the internal shift register with the positive edge of CLK.</p>

10 CLK	<p style="text-align: center;">Serial Control Input Equivalent</p>	<p>3-Wire bus input: Clock Clock input of the serial control interface with Schmitt-Trigger input stage</p>
11 LD/fo	<p style="text-align: center;">LD as Lock Detector</p>	<p>Lock detector output Unipolar output of the phase detector in the form of a pulse-width modulated signal. In the locked state the output signal is at H-level. In standby mode the output is resistive. For test purpose the push pull output fo is enabled.</p>
12 Rext	<p style="text-align: center;">OSW Output Equivalent</p>	<p>CP& Prescaler reference current setting External resistor for CP & Prescaler reference current setting.</p>
13 RI	<p style="text-align: center;">RI Input Equivalent</p>	<p>Reference frequency input Input with highly sensitive preamplifier. With small input signals AC coupling must be set up, where DC coupling can be used for large input signals.</p>
14 GND2		Ground for bipolar circuitry

<p>15</p> <p>IFX</p>	<p style="text-align: center;">RF and IF Input Equivalent</p>	<p>IF frequency input (inverted) IF input with highly sensitive preamplifier for PLL2. AC coupling must be set up.</p> <p>IF frequency input IF input with highly sensitive preamplifier for PLL2. AC coupling must be set up.</p>
<p>17</p> <p>GND1</p>		<p>Ground for CMOS circuitry</p>
<p>18</p> <p>CP2</p>	<p style="text-align: center;">PD Output Equivalent</p>	<p>Phase detector tristate charge pump output for PLL2</p>
<p>19</p> <p>VPD2</p>		<p>Positive supply voltage for charge pump 2.</p>
<p>20</p> <p>VCC2</p>		<p>Positive supply voltage for bipolar circuitry</p>

3.3 Functional Block Diagram

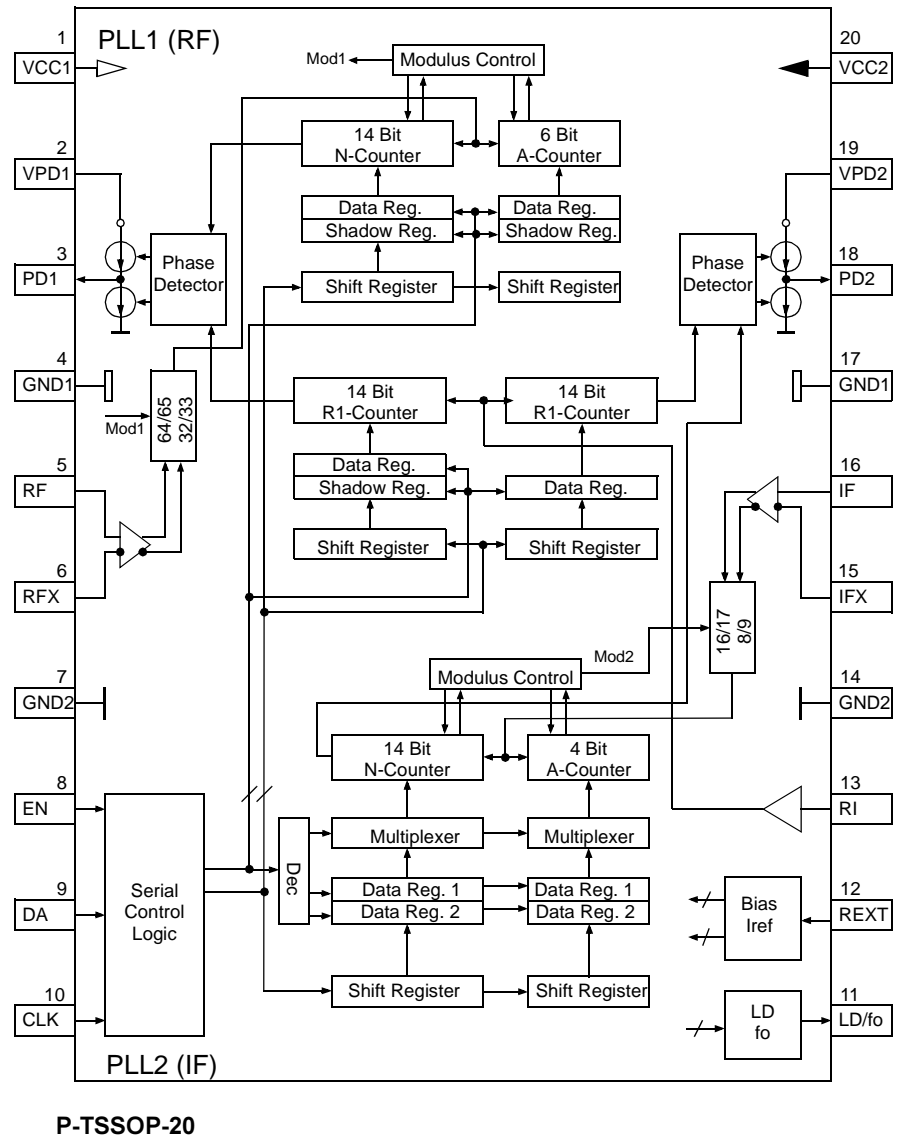

Funct_block.wmf

Figure 3-2 Functional Block Diagram

3.4 Circuit Description

1. General Description

The PMB 2347 consists of two fully programmable PLLs, one for the RF and one for the IF frequency range. Each PLL contains a high frequency dual modulus prescaler, an A- and a N-counter with dual modulus control logic, a reference- (R-) counter, and a phase detector with charge pump output. The two synthesizers are controlled via the common serial 3-wire interface.

The reference frequency is applied at the common RI-input and divided by the R-counter of each PLL. Its maximum value is 45 MHz. The RF and IF input frequencies will be divided by the corresponding prescalers with a programmable 32/32 or 64/65 (RF) and 8/9 or 16/17 (IF) divide ratio and the following programmable A/N-counters. The maximum RF frequency value is 2.8 GHz and 500 MHz for the IF frequency.

The phase and frequency detectors with the charge pumps have a linear operating range without a dead zone for very small phase deviations.

The multifunctional output port LD/fo can be programmed as lock detector and test output.

2. Programming

Programming of the IC is done via the serial data interface. The content of the bus telegram (serial data format) is assigned to the functional units according to the address.

The most significant bit (MSB) of the serial data formats is shifted first.

The *short control data format* allows a fast PD-current change.

The *long control data format* allows the programming of asynchronous or synchronous data acquisition of PLL1 (RF), 4 different PD-output current modes for the PLL1 and 1 PD-output current modes for PLL2, polarity setting of the PD-output signals, 2 standby modes, charge pump pulse width and the prescaler divide ratio.

The *A/N-counter data format* of PLL1 contains the A/N-counter value.. The data format of PLL2 comprise the counter values as well.

The *R-counter data format* contains the R-counter values.

The PLL1 (RF) of PMB 2347 offers the possibility of synchronous counter and charge pump current programming to avoid phase errors at the phase detector when R- and A-/N-counter are programmed one after another or the charge pump current is altered.

Asynchronous Mode:

The serial data is written directly to the data registers of the addressed counter with the Enable pulse. As each counter is loading the new starting value after it is decremented to „zero“, the counters changes therefore their counter values asynchronously to the others.

Synchronous Mode (only for RF):

In this mode counter programming is controlled by the R- and N-counters. The serial data (exception: higher part of long control data format) is first written with the Enable pulse to the corresponding shadow registers. From there the values for R-counter, A-/N-counter and charge pump current values of short/long control data format are loaded into the corresponding data register when the N-counter reaches „zero+1“. Therefore the change of all counter states is synchronised to the reloading of the N-counter to avoid additional phase error caused by the programming. The transfer of the charge pump current values into the corresponding data register is tied to the N-counter loading, but follows the loading of the N-data register in the distance of one N-counter dividing ratio. This guarantees that a new PD-current value becomes valid at the same time when the counters are loaded with the new data.

Synchronous programming sequence:

1. Setting of synchronous counter programming by bit c13 of long control data format.
2. Programming of the R-counter, and optional short control data format. With the Enable signal data is loaded into the shadow registers.
3. Programming of the A/N-counter. Data is loaded into shadow registers, the EN-signal starts the synchronous transfer to the data registers.

Synchronous data programming is of especial advantage, when large frequency steps are to be made in a short time. For this purpose a high reference frequency can be programmed in order to achieve rapid – “rough” – transient response. This method increases the fundamental frequency by nearly the square root of the reference frequency ratio and therefore the settling time is reduced. When rough lock is achieved, another synchronous data transfer is needed to switch back to the original channel spacing. A “fine” lock in will finish the total step response. It may not be necessary to change reference frequency, but it make sense to perform synchronous data acquisition in any case. Especially for GSM, PCN (DCS 1800) and PCS systems the synchronous mode should be used to achieve best performance of the PMB 2347.

3. Standby Condition (power down)

Each PLL of the PMB 2347 has two programmable standby modes to reduce the current consumption (standby 1, standby 2).

Standby 1: The corresponding PLL is switched off, the current consumption is reduced below 1 μ A.

Standby 2: The corresponding counters, the charge pump and the outputs are switched off. Only the preamplifier of RI-input stays active.
(See standby table)

4. Divide ratio programming

The frequency of an external VCO controlled by the PMB 2347 is given below:

$$f_{VCO} = [(P \cdot N) + A] \cdot \frac{f_{RI}}{R} = \frac{M}{R} \cdot f_{RI}$$

with $A \leq N$.

f_{VCO} :	frequency of the external VCO
f_{RI} :	reference frequency
N:	divide ratio of the N-counter
A:	divide ratio of the A-swallow counter
P:	divide ratio of the prescaler
R:	divide ratio of the R-counter
$M=P \cdot N + A$:	total divide ratio

Note: for continuous frequency steps following condition is necessary
 $[P \cdot N + A] \geq P \cdot (P - 1)$

5. Prescaler Divide Ratio

For the highest input frequencies of the prescalers the larger divide ratio is necessary:

RF-PLL:	64/65 for frequencies greater 1500 MHz
IF-PLL:	16/17 for frequencies greater 375 MHz

6. Fast wake-up programming

When the circuit is connected to the supply voltage all registers are undefined. Due to the fact that each counter is loading its new start value after it is decremented to „zero“, the start-up time of the counters with the programmed values is too long for some applications. If the counters are programmed in standby mode 2 and the PLLs are switched afterwards in operating mode, the counters are starting immediately with the programmed values. Therefore following data transfer sequence is recommended:

Table 3-2 Fast Wake Up Data Transfer Sequence	
Step	Serial Data Transfer Sequence
1	Long Control Word: Asynchronous Mode, Standby2
2	R-Counter
3	A-/N-Counter
4	Long Control Word: Synchronous Mode, Operating Mode

7. Phase Detector Outputs

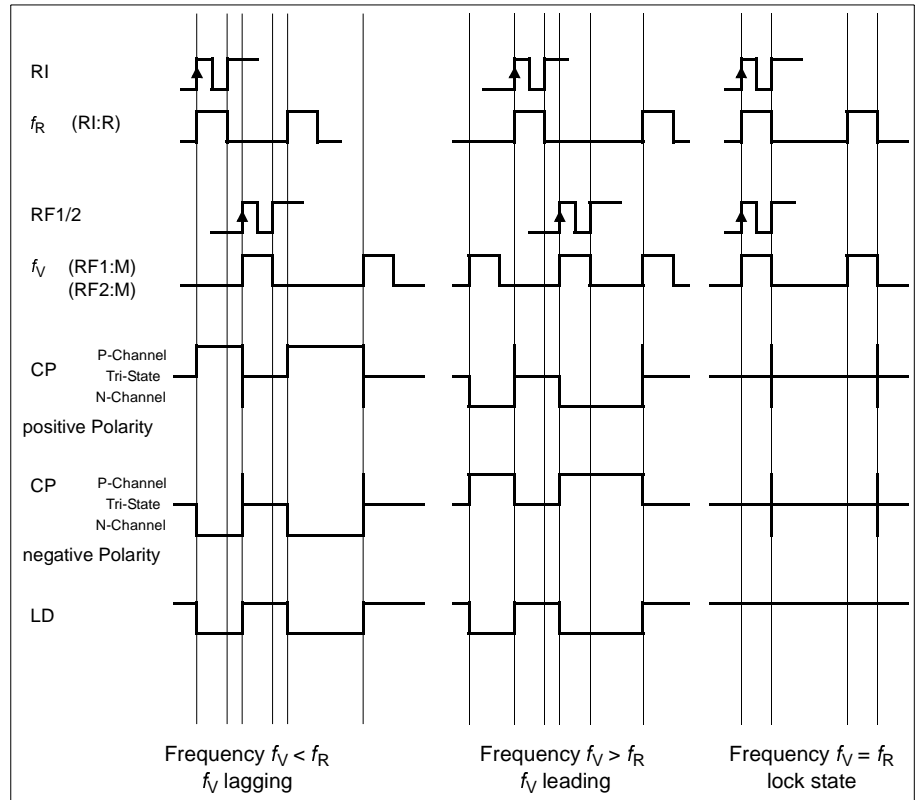

The timing diagram is valid for PLL1 and PLL2.

4 Applications

Contents of this Chapter

4.1	Hint	4-2
-----	------------	-----

4.1 Hint

More Information about "Application" see in separate Document

APPLICATION NOTE PMB 2347.

5 Reference

Contents of this Chapter

5.1	Electrical Data.	5-2
5.2	Serial Control Data Format Timing	5-7
5.3	Serial Control Data Formats	5-8
5.4	Input Sensitives	5-13
5.5	Charge Pump Currents.	5-15
5.6	Threshold Voltages of Schmitt-Trigger Input	5-16

5.1 Electrical Data

5.1.1 Absolute Maximum Ratings



WARNING

The maximum ratings may not be exceeded under any circumstances, not even momentarily and individually, as permanent damage to the IC will result.

Table 5-1 Absolute Maximum Ratings

Parameter	Symbol	Limit Values		Unit	Remarks
		min	max		
Supply Voltage	$V_{CC1/2}$	-0.3	5.5	V	
Input Voltage	V_I	-0.3	$V_{CC1/2} + 0.3$	V	
Output Voltage	V_O	GND	$V_{CC1/2}$	V	
Total power dissipation	P_{tot}		300	mW	
Ambient temperature	T_A	-40	85	°C	in operation
Storage temperature	T_{Stg}	-50	125	°C	
Thermal Resistance	R_{thJA}		170	K/W	
ESD Integrity (according to MIL 883 Method 3015.7) except Pins Vpd1[2] and Vpd2[19]	V_{ESD}		0.5	KV	preliminary

5.1.2 Operating Range

Within the operational range the IC operates as described in the circuit description.

The AC/DC characteristic limits are not guaranteed.

Table 5-2 Operating Range, $V_{CC1/2} = 2.7V - 5.0V$, $T_{AMB} = -40^{\circ}C \dots + 85^{\circ}C$ typical

Parameter	Symbol	Limit Values		Unit	Test Conditions	Item
		min	max			
Supply Voltage	$V_{CC1/2}$	2.7	5.0	V		
Input frequency RF	f_{RF}	250	2800	MHz	$V_{CC1/2} = 3.6V$	
Input frequency IF	f_{IF}	100	500	MHz		
Input reference frequency	f_{RI}	1	45	MHz		
CP-output current of PLL1	I_{CP1}		4 +20%	mA		
CP-output current of PLL2	I_{CP2}		1 +20%	mA		
CP-output voltages	$V_{CP1/2}$	0.5	$V_{PD1/2} - 0.5$	V		
Ambient temperature	T_A	-40	85	$^{\circ}C$		

5.1.3 Typical Supply Current I_{CC}

Table 5-3 Typical Supply Current I_{CC}

Parameter	Symbol	Limit Values			Unit	Test Conditions	Item
		min	typ	max			
Supply Voltage	$V_{CC1/2}$		3.6		V	$R_{EXT} = 12k$	
Supply current:						Note 1)	
PLL1 & PLL2 active	$I_{CC1/2}$	-20%	8.0	+20%	mA	$V_{CC1/2} = 3.6V$	
PLL1 active, PLL2 standby	$I_{CC1/2}$	-20%	5.9	+20%	mA		
PLL1 standby2, PLL2 active	$I_{CC1/2}$	-20%	3.2	+20%	mA		
PLL1 & PLL2 standby 2	$I_{CC1/2}$		120		μA		
PLL1 & PLL2 standby 1	$I_{CC1/2}$		< 1		μA		

1) $f_{RF1} = 900MHz$, $V_{RF} = 150mVrms$, $f_{RF2} = 420MHz$,
 $V_{RF2} = 150mVrms$, $f_{RI} = 10MHz$, $V_{RI} = 150mVrms$,
 $I_{CP1} = 4.0mA$, $I_{CP2} = 2.0mA$, $I_{ref} = 100 \mu A$

5.1.4 AC/DC Characteristics

AC/DC characteristics involve the spread of values guaranteed within the specified supply voltage and ambient temperature range. Typical characteristics are the median of the production.

Table 5-4 AC/DC Characteristics with $V_{CC1/2}=2.7 \dots 5.0 \text{ V}$, Ambient temperature $T_{amb}=-40^{\circ}\text{C}$ to 85°C

	Sym- bol	Limit Values			Unit	Test Conditions	L	Item
		min	typ	max				
Input Signals DA, CLK, EN (Schmitt-Trigger input stage)								
H-input voltage	V_{IH}	$0.7 V_{CC}$		V_{CC}	V			
L-input voltage	V_{IL}			$0.3 V_{CC}$	V			
Input capacity	C_I			5	pF			
H-input current	I_H			10	μA	$V_I=V_{CC2}=3.6\text{V}$		2.3
L-input current	I_L	-10			μA	$V_I=\text{GND}$		2.4

Input Signal RI

Input voltage	V_I	100			mVrms	$f=4-45 \text{ MHz}$, $V_{CC1}=3.6\text{V}$		2.10
Slew rate		4			V/ μs	$V_{CC1}=2.7-5.0 \text{ V}$		
Input capacity	C_I			3	pF			
H-input current	I_H			30	μA	$V_I=V_{CC1}=3.6\text{V}$		2.13
L-input current	I_L	-30			μA	$V_I=\text{GND}$		

Input Signals RF

Input voltage	V_I				mVrms	$f=150-450 \text{ MHz}$		3.1
	P_I	-12		+6	dBm			
Input voltage	V_I				mVrms	$f=450-2500 \text{ MHz}$		3.2
	P_I	-20		+4	dBm			
Input voltage	V_I				mVrms	$f=2500-2800 \text{ MHz}$		
	P_I	-10		-2.5	dBm			

Input Signals IF

Input voltage	V_I				mVrms	$f=100-350 \text{ MHz}$		4.1
	P_I	-16		+4	dBm			
Input voltage	V_I				mVrms	$f=350-450 \text{ MHz}$		4.2
	P_I	-25		-5	dBm			
Input voltage	V_I				mVrms	$f=450-600 \text{ MHz}$		
	P_I	-25		-15	dBm			

Table 5-4 AC/DC Characteristics with $V_{CC1/2}=2.7 \dots 5.0$ V, Ambient temperature $T_{amb} = -40^{\circ}\text{C}$ to 85°C (continued)

	Sym- bol	Limit Values			Unit	Test Conditions	Item
		min	typ	max			
Output Current ICP1							
"1.2 mA"	I_{CP1}	-20%	1.2	+20%	mA	$V_{PD1}=5.0\text{V}$, $V_{CP1}=V_{PD1}/2$ $I_{REF}=100\mu\text{A}$ *guaranteed by design	5.1
"2.0 mA"	I_{CP1}	-20%	2.0	+20%	mA		5.2
"2.8 mA"	I_{CP1}	-20%	2.8	+20%	mA		5.3
"4.0 mA"	I_{CP1}	-20%	4.0	+20%	mA		5.4
"Tristate"	$ I_{CP1} $		0.1	10*)	nA		5.5
Output Current ICP2							
"1.0 mA"	I_{CP2}	-20%		+20%	mA	$V_{PD2}=3.6\text{V}$, $V_{CP1}=V_{PD1}/2$ $I_{REF}=100\mu\text{A}$ *guaranteed by design	
"Tristate"	$ I_{CP2} $		0.1	10*)	nA		
Output Current Offset CP1 & CP2							
CP Supply Voltage	$V_{PD1/2}$	2.7	3.6	5.0	V	$V_{CP1/2} = V_{PD2}/2$	
CP Current Offsett	I_{CP-OFF}	-4	0	+13	%		
Magnitude Variation							
"1.2 mA"	I_{CPMV}		4		%	$V_{PD1}=5\text{V}$, $V_{CP1} = V_{PD1}/2$ $I_{REF}=100 \mu\text{A}$ see 'Chargepump Specification' for details on spurious suppression	
"2.0 mA"	I_{CPMV}		4		%		
"2.8 mA"	I_{CPMV}		4		%		
"4.0 mA"	I_{CPMV}		4		%		7.4
"-1.2 mA"	I_{CPMV}		6		%		
"-2.0 mA"	I_{CPMV}		6		%		
"-2.8 mA"	I_{CPMV}		6		%		
"-4.0 mA"	I_{CPMV}		6		%		7.8
Current Mismatch							
"1.2 mA"	I_{CPMM}		0.7		%	$V_{PD2}=5\text{V}$, $V_{CP2} = V_{PD2}/2$ $I_{REF}=100 \mu\text{A}$	
"2.0 mA"	I_{CPMM}		1.3		%		
"2.8 mA"	I_{CPMM}		1.8		%		
"4.0 mA"	I_{CPMM}		1.5		%		

**Table 5-4 AC/DC Characteristics with $V_{CC1/2}=2.7 \dots 5.0$ V, Ambient temperature $T_{amb} = -40^{\circ}\text{C}$ to 85°C
(continued)**

	Sym- bol	Limit Values			Unit	Test Conditions	L	Item
		min	typ	max				
Output Rext								
V_{Rext}	V_{Rext}		1.2		V	$V_{CC2} = 3.6\text{V}$, $R_{ext}=12\text{k}$		10.1
I_{Rext}	I_{Rext}		100		μA	$V_{CC2} = 3.6\text{V}$, $R_{ext}=12\text{k}$		
Output Signal BSW at BSW/LD-Pin (n-channel open drain)								
L-output voltage	V_{OL}			0.4	V	$V_{CC1} = 2.7 - 3.6\text{V}$, $I_{OL} = 0.3 \text{ mA}$		
Fall time	t_F		3	10	ns	$V_{CC1} = 3.6\text{V}$, $C_1 = 10\text{pF}$		

■ This value is only guaranteed in lab.

5.2 Serial Control Data Format Timing

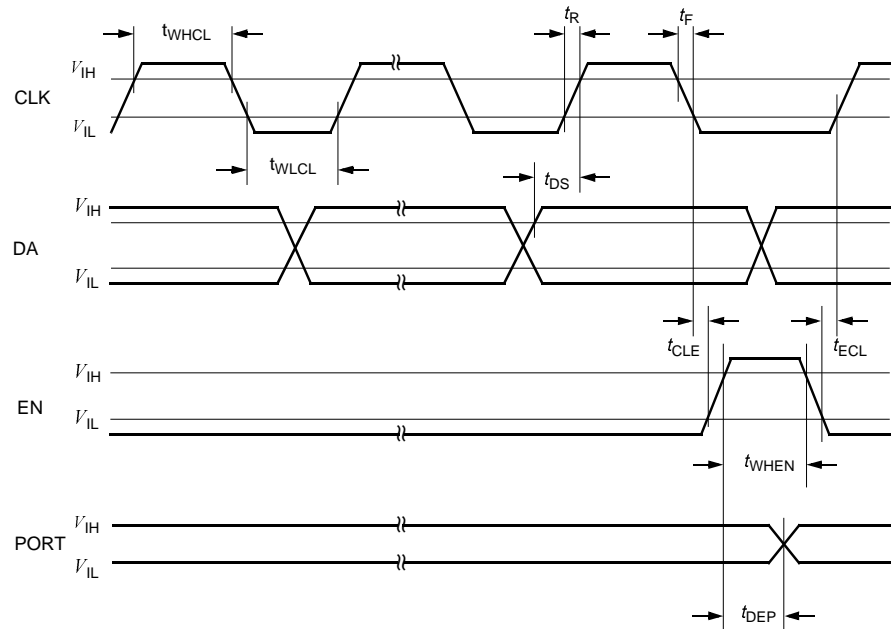
Table 5-5

Parameter	Symbol	Limit Values		Unit
		min.	max.	
Clock frequency	f_{CL}		15	MHz
H-pulsewidth (CLK)	t_{WHCL}	30		ns
L-pulsewidth (CLK)	t_{WLCL}	30		ns
Data setup	t_{DS}	20		ns
Setup time Clock-Enable	t_{CLE}	20		ns
Setup time Enable-Clock	t_{ECL}	20		ns
H-pulsewidth (Enable)	t_{WHEN}	60		ns
Rise, fall time	t_R, t_F		10	μ s
Propagation delay time EN-PORT	t_{DEP}		1	μ s

5.3 Serial Control Data Formats

Table 5-6 Address of Data Formats

Address			Data Format	Addressed PLL
a2	a1	a0		
0	0	0	Short Control Data Format	PLL1 (RF)
0	1	0	Long Control Data Format	PLL1 (RF)
1	0	0	A-/N-Counter	PLL1 (RF)
1	1	0	R-Counter	PLL1 (RF)
0	0	1	Short Control Data Format	PLL2 (IF)
0	1	1	Long Control Data Format	PLL2 (IF)
1	0	1	A-/N-Counter	PLL2 (IF)
1	1	1	R-Counter	PLL2 (IF)

In general each PLL can independently be addressed without affecting the other PLL (See also Test Modes).

NOTE: MSB of all serial data is shifted first

Table 5-7 Short Control Data Formats

PLL 1				PLL 2			
Bit	Bit	Function		Bit	Bit	Function	
LSB				LSB			
0	0	a0	Address	0	1	a0	Address
1	0	a1	Address	1	0	a1	Address
2	0	a2	Address	2	0	a2	Address
3		c0	LD InActive	3		c0	reserved
4		c1	CP current 2	4		c1	reserved
5		c2	CP current 1	5		c2	CP current
6		c3	PLLsel	6		c3	reserved
MSB				MSB			

Table 5-8 Long Control Data Formats

PLL 1				PLL 2			
Bit	Bit	Function		Bit	Bit	Function	
LSB				LSB			
0	0	a0	Address	0	1	a0	Address
1	1	a1	Address	1	1	a1	Address
2	0	a2	Address	2	0	a2	Address
3		c0	LD inactive	3		c0	reserved
4		c1	CP current 2	4		c1	reserved
5		c2	CP current 1	5		c2	CP current 1
6		c3	PLLsel	6		c3	Data-Reg Select
7		c4	PSC Div. Ratio	7		c4	PSC Div. Ratio

Table 5-9 Long Control Data Formats (continued)

PLL 1			PLL 2		
Bit	Bit	Function	Bit	Bit	Function
8	c5	reserved	8	c5	reserved
9	c6	CPP width 2	9	c6	CPP width 2
10	c7	CPP width 1	10	c7	CPP width 1
11	c8	standby 2	11	c8	standby 2
12	c9	standby 1	12	c9	standby 1
13	c10	CP polarity	13	c10	CP polarity
14	c11	Mode 2	14	c11	reserved
15	c12	Mode 1	15	c12	reserved
16 MSB	c13	Sync/Async Mode	16 MSB	c13	reserved

Table 5-10 A/N-counter Data Formats

PLL 1			PLL 2		
Bit	Bit	Function	Bit	Bit	Function
LSB			LSB		
0	0	a0 Address	0	1	a0 Address
1	1	a1 Address	1	0	a1 Address
2	0	a2 Address	2	1	a2 Address
3	LSB	n0	3	LSB	n0
4		n1	4		n1
5		n2	5		n2
6		n3	6		n3
7		n4	7		n4
8		n5	8		n5
9		n6 N1-Counter	9		n6 N2-Counter
10		n7	10		n7
11		n8	11		n8
12		n9	12		n9
13		n10	13		n10
14		n11	14		n11
15		n12	15		n12
16	MSB	n13	16	MSB	n13
17	LSB	ac0	17	LSB	ac0
18		ac1	18		ac1 A2-Counter
19		ac2	19		ac2
20		ac3 A1-Counter	20	MSB	ac3
21		ac4			
22	MSB	ac5			

Table 5-11 R-counter Data Formats

PLL 1				PLL 2			
Bit	Bit	Bit	Function	Bit	Bit	Bit	Function
LSB				LSB			
0	0	a0	Address	0	1	a0	Address
1	1	a1	Address	1	1	a1	Address
2	1	a2	Address	2	1	a2	Address
3	LSB	r0	R1-Counter	3	LSB	r0	R2-Counter
4		r1		4		r1	
5		r2		5		r2	
6		r3		6		r3	
7		r4		7		r4	
8		r5		8		r5	
9		r6		9		r6	
10		r7		10		r7	
11		r8		11		r8	
12		r9		12		r9	
13		r10		13		r10	
14		r11		14		r11	
15		r12		15		r12	
16	MSB	r13		16	MSB	r13	
MSB			MSB				

Table 5-12 Programming of Operation and Test Modes

c12 Mode 1	c11 Mode 2	c3 PLLsel	Functional Mode	Affected Output: Pin 11 = BSW/LD
0	0	0	Test 1	fvn1 (PLL1)
1	0	0	Test 2	frn1 (PLL1)
0	1	0	reserved	frn1 (PLL1)
1	1	0	NORMAL OPERATION, LD of PLL1 active	Lock Detect PLL1
0	0	1	Test 3	fvn2 (PLL2)
1	0	1	Test 4	frn2 (PLL2)
0	1	1	reserved	frn2 (PLL2)
1	1	1	NORMAL OPERATION, LD of PLL2 active	Lock Detect PLL2

Table 5-13 Programming of CP Current of PLL1

c2 CP current 1	c1 Mode 2	CP Current [mA]	Remark
0	0	1.2 mA	with 100µA reference current
1	0	2.0 mA	
0	1	2.8 mA	
1	1	4.0 mA	

Table 5-14 Programming of CP Current of PLL2

c2 CP current 1	CP Current [mA]	Remark
0	Tristate	with 100µA reference current
1	1.0 mA	

Table 5-15 Programming of Charge Pump Pulse Width of both PLLs

c7 CPP width 1	c6 CPP width 2	Pulse Width [ns] typ.	Remark
0	0	1.6 ns	not recommended for PLL2
1	0	6.0 ns	
0	1	9.0 ns	
1	1	13.0 ns	

Table 5-16 Standby of Power Down Programming of both PLLs

Control Bits		Mode	Affected Output Pins Z: High Impedance (Tristate)		
c9 standby 1	c8 standby 2		Pin 11 LD/fo	Pin 3 CP1	Pin 18 CP2
0	0	standby1	off	Z	Z
1	0	standby2	off	Z	Z
0	1	standby1	off	Z	Z
1	1	Operation Mode	active	active	active

Table 5-17 Programming of Synchronous/Asynchronous Mode of PLL1

c13 Sync/Async	Synchronous/Asynchronous Mode
0	Asynchronous Mode of PLL 1
1	Synchronous Mode of PLL 1

Table 5-18 Programming of PD Polarity of both PLLs

Control Bit	PD Polarity
c10 PD Polarity	
0	negative Polarity
1	positive Polarity

Table 5-19 Programming of Prescaler Divide Ratio of both PLLs

Control Bit	Prescaler Divide Ratio	
c4 PSC Div. Ratio		
0	PLL1: 32/33	PLL2: 8/9
1	PLL1: 64/65	PLL2: 16/17

Table 5-20 Programming of PLL Select

Control Bit	PLL Select
c3 of PLL1	
0	PLL1 (RF)
1	PLL2 (IF)

Table 5-21 Programming of Data Register Select

Control Bits	IF Data Register Select
c3 of PLL2	
0	Data Register 1
1	Data Register 2

5.4 Input Sensitives

The following sections show the typical performance at +25°C.

1. Typical RF Sensitivity:

The PLL setup is: Psc:64/65. N:3, A:0, IF-PLL is in standby mode. V_{CC} is 2.7 V. The testport open-drain pin is pulled to 2.0 V over 5k1. The cut-off frequency can be increased to typ. >3.45GHz by using a V_{CC} of 5.0 V

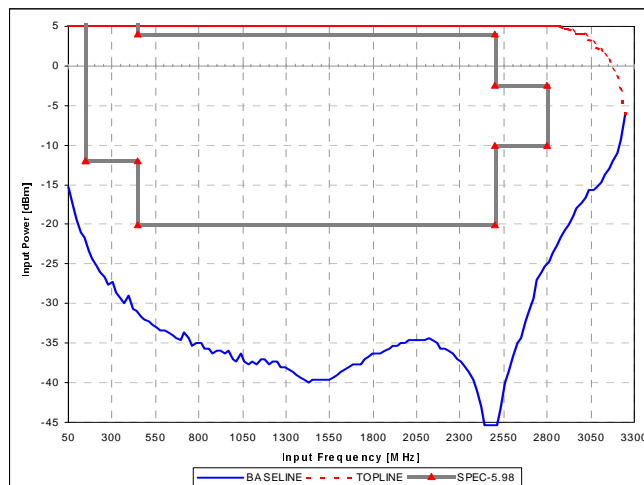

2. Typical IF Sensitivity:

The PLL setup is: Psc:16/17. N:3, A:1, RF-PLL is in standby mode. V_{CC} is 2.7 V. The testport open-drain pin is pulled to 2.0 V over 5k1.

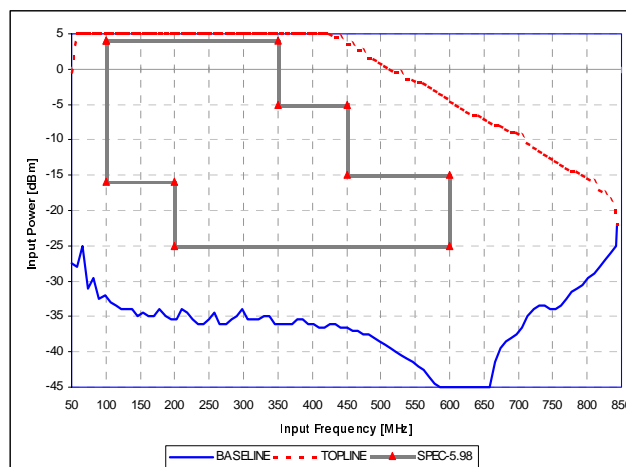

3. Typical Ri Sensitivity:

The PLL setup is: R:3; RF-PLL is in standby mode. V_{CC} is 3.6V.

The testport open-drain pin is pulled to 2.0 V over 5k1.

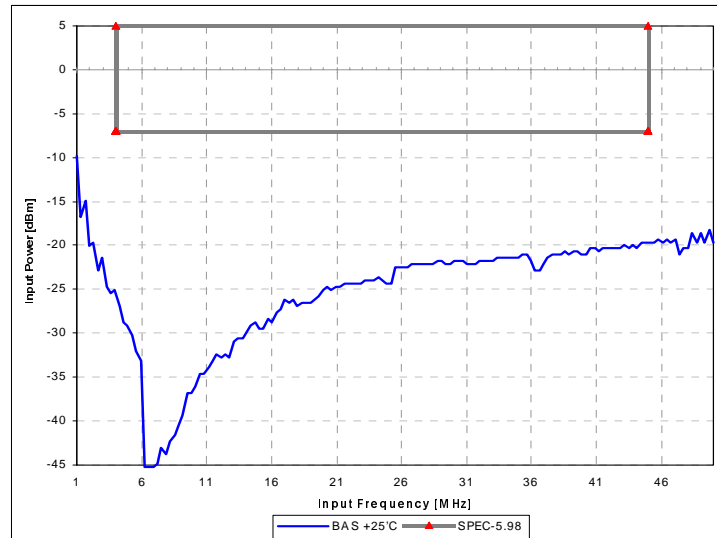

5.5 Charge Pump Currents

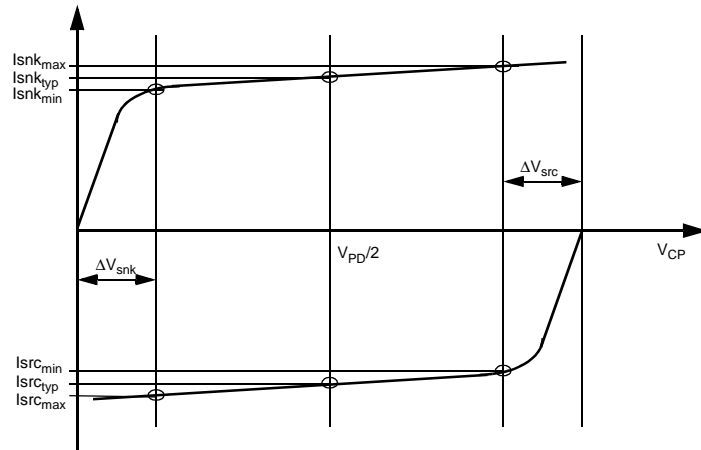

Figure 5-1 Definition of Charge Pump Currents

Terms and Abbreviations:

V_{PD}	Supply Voltage of Charge Pump
$\Delta V_{src/snk}$	Offset Voltage from GND or V_{PD}
I_{snk_max}	Maximum Sink Current @ $V_{PD}-\Delta V_{SRC}$
I_{src_max}	Maximum Source Current @ $GND+\Delta V_{SNK}$
I_{snk_typ}	Typical Sink Current @ $V_{PD}/2$
I_{src_typ}	Typical Source Current @ $V_{PD}/2$
I_{snk_min}	Minimum Sink Current @ $GND+\Delta V_{SNK}$
I_{src_min}	Minimum Source Current @ $V_{PD}-\Delta V_{SRC}$

Specification of Charge Pump Characteristics:

Charge Pump Output Magnitude Variation CPMV:

$$\frac{I_{snk_max} - I_{snk_min}}{2} \cdot 100\% \quad \frac{I_{src_max} - I_{src_min}}{2} \cdot 100\%$$

$$\frac{I_{snk_max} + I_{snk_min}}{2} \quad \frac{I_{src_max} + I_{src_min}}{2}$$

Charge Pump Current Mismatch CPCM:

$$\frac{I_{snk_typ} - I_{src_typ}}{2} \cdot 100\%$$

$$\frac{I_{snk_typ} + I_{src_typ}}{2}$$

Spurious Suppression:

Presuming a standard GSM-application - *RF: 900MHz, PD frequency: 200kHz, V_{cc}: 2.7V, T_A: -40...+85°C* - for spurious suppression better than 70dB, it is recommendet that

$$\Delta V_{PD} \text{ should be within } \Delta V_{SNK} \text{ and } V_{cc} - \Delta V_{SNK}$$

5.6 Threshold Voltages of Schmitt-Trigger Input

